

MAXIMA NEW O





POWER MAX, THE NEW WINNING SOLUTION FOR THE PLANT ROOM

POWER MAX IS THE NEW BERETTA SOLUTION AS MODULAR CONDENSING WALL-HUNG BOILER SYSTEM

Fully designed, developed and industrialized by Beretta, **complete with all flue options, hydraulic and safety accessories**, POWER MAX is the **ideal choice** for central heating systems of large domestic properties and commercial buildings, like hotels, sports centres, schools, office buildings, factories, etc.

Thanks to the **countless possible configurations as stand-alone or cascade application up to 1120 Kw**, POWER MAX is Beretta winning solution both **for new buildings and renovations, from energy retrofitting to the replacement of old boiler systems**.

The **ease of mounting and the maximum flexibility of installation**, combined with **high efficiency and low emissions**, make this product stand out in the category of commercial and light commercial appliances.

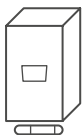

STAND-ALONE
CONFIGURATIONS

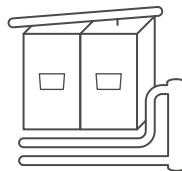

LINEAR CASCADE
CONFIGURATIONS

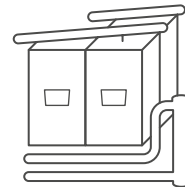

BACK-TO-BACK
CASCADE CONFIGURATIONS



LOW NOX COMPLIANT
CLASS 6

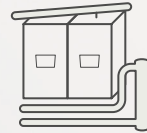

CASCADE SYSTEMS
UP TO 1120 KW



DIGITAL
ELECTRONIC
CONTROL



PATENTED
STAINLESS STEEL
HEAT EXCHANGERS



BUILT-IN PUMP
UP TO 70 KW



WIDE RANGE OF
ACCESSORIES

POWER MAX, A REAL INNOVATION

POWER MAX IS AN INNOVATIVE PRODUCT WITHIN BERETTA CONDENSING MODULAR SYSTEMS

All the components of the previous range have been re-examined and redesigned: the heat exchanger works with surface temperatures decreased by 18% to reduce

thermal shock and increase the lifespan; polluting **emissions** have been reduced below the **most stringent limits** (Class 6 NOx according to UNI EN 15502); the **system control** is 10 times faster than the previous one. A new, wider range of accessories is also available as standard.

- › **NEW PATENTED CONDENSING HEAT EXCHANGERS** MADE OF STAINLESS STEEL.
- › **8 VERSIONS** FROM 34.9 TO 131 KW, THAT CAN BE INSTALLED IN STAND-ALONE OR CASCADE CONFIGURATION.
- › **POSSIBLE CASCADE CONFIGURATIONS UP TO 1120 KW** WITH EMBEDDED 'MANAGING/DEPENDING' CONTROL LOGICS.
- › POSSIBLE CASCADE CONFIGURATIONS WITH **FRAME: LINEAR OR BACK-TO-BACK**.
- › **MODULATING AND MODULAR POWER REGULATION** WITH AUTOMATIC BURNER IGNITION SEQUENCE REVERSAL.
- › **SIMULTANEOUS MANAGEMENT OF TWO DIFFERENT CIRCUITS: DHW TANK AND HIGH TEMPERATURE. UP TO 16 ADDITIONAL MIXED ZONES** AVAILABLE AS ACCESSORY.
- › **AUTOMATIC SUMMER/WINTER REVERSAL**.
- › **'ANTI-LEGIONELLA' FUNCTION AS STANDARD**.
- › **SUITABLE FOR REMOTE CONTROL MANAGEMENT** (0-10 V INPUT OR MODBUS) VIA OPTIONAL KIT.
- › AVAILABILITY OF A **WIDE RANGE OF SYSTEM ACCESSORIES**.
- › **LPG CONVERSION KIT SUPPLIED AS STANDARD**.

THE RANGE

The POWER MAX range is available in **8 models**, starting from 34.9 kW up to 131 kW.
The **installation** can be **stand-alone** or it is possible to connect **in cascade several POWER MAX units of the same model** until reaching a maximum output of 1.12 MW.



POWER MAX 50 P DEP

POWER MAX 50 P

POWER MAX 65 P

POWER MAX 80 P

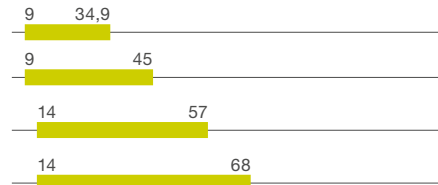

POWER MAX 100

POWER MAX 110

POWER MAX 130

POWER MAX 150

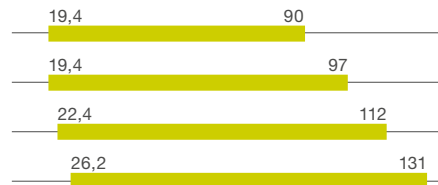

DEP MODEL INDICATES A REDUCED OUTPUT BOILER APPROVED BY THE MANUFACTURER.

P MODELS INDICATE THAT THE BOILERS ARE SUPPLIED AS STANDARD WITH A BUILT-IN CIRCULATION PUMP.

THE **OTHER MODELS** ALLOW TO INSTALL A CIRCULATION PUMP (AS OPTIONAL KIT) OR A 2-WAY VALVE, OUTSIDE THE BOILER.

Model	CH Flow F	CH Return R	Gas G	Flue gas outlet O	Air intake I
POWER MAX 50 P DEP	1" 1/2	1" 1/2	1"	DN80	DN80
POWER MAX 50 P	1" 1/2	1" 1/2	1"	DN80	DN80
POWER MAX 65 P	1" 1/2	1" 1/2	1"	DN80	DN80
POWER MAX 80 P	1" 1/2	1" 1/2	1"	DN80	DN80

POWER MAX 100	1" 1/2	1" 1/2	1"	DN110	DN110
POWER MAX 110	1" 1/2	1" 1/2	1"	DN110	DN110
POWER MAX 130	1" 1/2	1" 1/2	1"	DN110	DN110
POWER MAX 150	1" 1/2	1" 1/2	1"	DN110	DN110

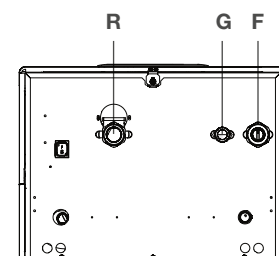
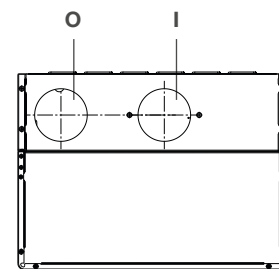

HIGH OUTPUT FROM COMPACT DIMENSIONS

POWER MAX stands out for its compact dimensions, a feature increasingly appreciated also in the plant room, which further enriches the profile of high installation flexibility of the product.



WIDTH

600 mm
for all models

HEIGHT

1000 mm
for the models:
50 P DEP, 50 P, 65 P, 80
P, 100, 110

1165 mm

for the models: 130, 150

DEPTH

435 mm
for all models

TECHNOLOGY: COMBUSTION

THE NEW HEAT EXCHANGER

POWER MAX heat exchanger, designed in absolute symbiosis with the pre-mixed gas burner, represents one of the **top technological advantages of the system**. In fact, from a good synergy between combustion and heat exchange derives the best transformation of the chemical energy of the fuel into useful heat energy to be transmitted to water. POWER MAX heat exchanger is made of high quality **stainless steel** so as to ensure its unchangeability and reliability over time. Design, water path and flow sections have been optimised to **limit**

pressure drops and ensure the **best heat transfer**.

This results in a more homogeneous “wall temperature”, which means **longer lifespan** and **better performance**. The pre-mixed burner has also been designed to keep polluting emissions below the most restrictive European limits, allowing POWER MAX to be in **Class 6 NOx** according to UNI EN 15502, the best one.

POWER MAX models feature two different types of heat exchangers as in the following tables.



VERSIONS UP TO 45 kW
POWER MAX 50 P DEP - 50 P

- > HELICAL HEAT EXCHANGER
- > MATERIAL: STAINLESS STEEL
- > SINGLE-TUBE WITH SMOOTH SURFACE
- > P-SHAPED PROFILE FOR HIGH HEAT EXCHANGE

ADVANTAGES
Compact design.
No direct exposure of the plating to the flame, which allows lower surface temperatures, with subsequent **reduction in heat loss**.

Optimised profile:
- to fully exploit the whole available surface, translating into **increased exchange surface**;
- to facilitate **condensate drainage**, preventing stagnation.

High reliability thanks to the use of steel with great tube thickness (1.2 mm).

VERSIONS FROM 57 TO 131 KW

POWER MAX 65 P - 150

- > HELICAL HEAT EXCHANGER
- > MATERIAL: STAINLESS STEEL
- > DOUBLE TUBE, WITH SMOOTH CONCENTRIC TUBES
- > FIVE-SIDED SHAPE PROFILE FOR INTERNAL TUBE AND ROUND SHAPE PROFILE FOR EXTERNAL TUBE
- > HYDRAULIC CIRCULATION IN PARALLEL

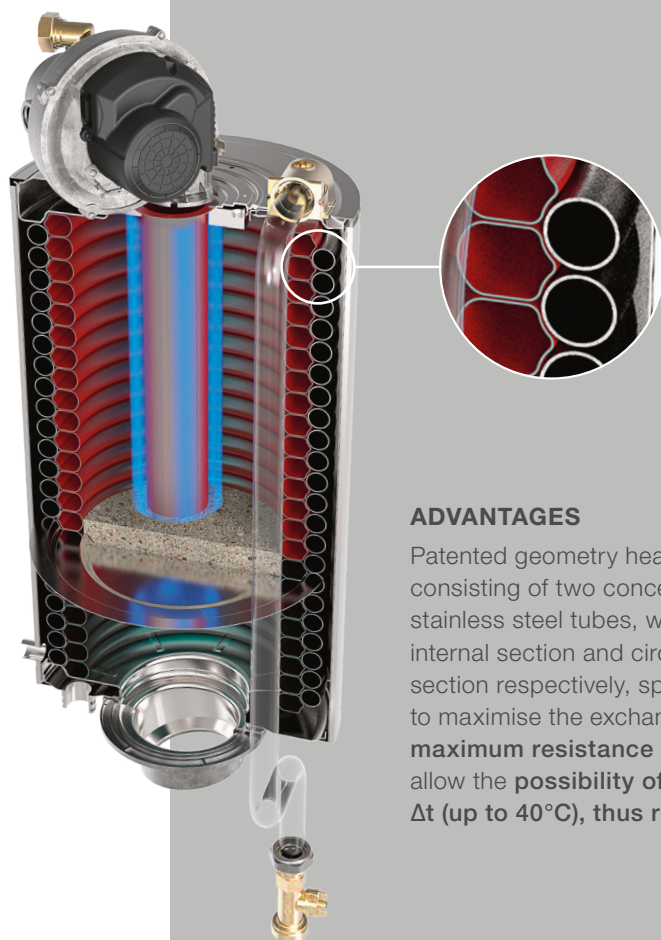

ADVANTAGES

Patented geometry heat exchanger, consisting of two concentric smooth stainless steel tubes, with pentagonal internal section and circular external section respectively, specifically designed to maximise the exchange surface, offer **maximum resistance to corrosion** and allow the **possibility of working with high Δt (up to 40°C)**, thus reducing setup times.



**REPRESENTATIVE INTERNAL VIEW OF
POWER MAX
(models 65 P - 150)**

TECHNOLOGY: THE STRUCTURE

The heat module of POWER MAX is designed for **open flue operation, which can be converted to room-sealed flue**, using the appropriate accessory. All models are provided with flowmeter for control of the minimum flow rate on the delivery tube, and a minimum pressure

switch on the return tube to check the minimum pressure and detect the return temperature (ΔT control) for modulating pump control (PWM).

The flue gas temperature probe checks the correct operation and the request for cleaning of the heat exchanger, if any.

KEY

- 01 FLUE GAS ANALYSIS OUTLET
- 02 FLUE GAS CONNECTION
- 03 GAS VALVE
- 04 FAN
- 05 COMBUSTION CHAMBER
- 06 ELECTRICAL PANEL
- 07 FLUE GAS CLAPET VALVE
- 08 DRAIN TAP
- 09 MINIMUM PRESSURE SWITCH CALIBRATED AT 0.7 BAR
- 10 CIRCULATION PUMP (FITTED AS STANDARD ON P MODELS, AVAILABLE AS AN ACCESSORY FOR THE OTHER MODELS)
- 11 FLOWMETER
- 12 FLUE GAS PROBE
- 13 RETURN PROBE
- 14 CONTROL PANEL
- 15 IGNITION/ DETECTION ELECTRODE
- 16 SAFETY THERMOSTAT WITH MANUAL RESET FROM BOARD
- 17 DELIVERY PROBE
- 18 AUTOMATIC DRAIN VALVE
- 19 CASING PANELS



- 20 EXPANSION VESSEL
- 21 3-WAY VALVE

The models **50 P DEP and 50 P** feature a different heat exchanger, as described in the previous pages, and **allow installing a 3-way valve inside the boiler** for the production of domestic hot water.

It is also **possible to install an optional expansion vessel** inside the boiler itself.

TECHNICAL DATA

Description	u.o.m.	POWER MAX									
		50 P DEP	50 P	65 P	80 P	100	110	130	150		
Type of appliance		Condensing heat appliance B23, B53; B53P									
Fuel		G20-G25-G30-G31									
Appliance category		I12H3P									
Combustion chamber		vertical									
Maximum nominal heat input at furnace referred to the HCV (LCV)	kW	38,7 (34,9)	50 (45)	63 (57)	76 (68)	100 (90)	108 (97)	124 (112)	146 (131)		
Minimum nominal heat input at the furnace referred to the HCV (LCV)	kW	10 (9)	10 (9)	15 (14)	15 (14)	21,6 (19,4)	21,6 (19,4)	24,9 (22,4)	29,2 (26,2)		
Useful (nominal) heat output	kW	34,4	44,2	56	68	88	95	110	129		
Maximum nominal heat output (80-60°C)	P4	G20	kW	34,4	44,2	55,7	67,0	88,3	95,3	109,8	129,0
Maximum nominal heat output (50-30°C)	-	G20	kW	38,0	48,8	61,9	73,9	97,4	105,1	121,1	142,1
Maximum nominal heat output (60-40°C)	-	G20	kW	36,6	47,0	59,6	71,4	93,8	101,1	116,2	137,3
Heat output 30% with return 30°C	P1	G20	kW	11,5	14,7	18,7	22,3	29,4	31,7	36,6	43,0
Minimum nominal heat output (80-60°C)	-	G20	kW	8,9	8,9	13,5	13,5	19,2	19,2	22,1	26
Seasonal space heating energy efficiency class			A	A	A	A	-	-	-	-	
Seasonal space heating energy efficiency	ηs		%	93,1	93,1	93,1	93,1	-	-	-	-
Efficiency at nominal heat input and high temperature regime HCV (LCV)	η4	Useful heat input (60-80°C)	%	88,5 (98,4)	88,4 (98,3)	88,4 (98,3)	88,2 (97,9)	88,3 (98,0)	88,2 (97,9)	88,6 (98,3)	88,2 (97,9)
Efficiency at 30% of nominal heat input and low temperature regime HCV (LCV)	η1	Useful heat input 30%	%	98,4 (109,5)	98,2 (109,2)	98,2 (109,2)	98 (108,8)	98,1 (108,9)	98 (108,8)	98 (108,8)	98,1 (108,9)
Losses through chimney with burner operating at max nominal output (80-60°C)			%	2,3	2,3	2,3	2,3	2,5	2,6	2,5	2,6
Losses at chimney with burner operating at 30% of nominal output (50-30°C)			%	0,5	0,5	0,5	0,5	0,6	0,6	0,5	0,6
Thermal losses in Standby mode	Pstby		W	45	57	72	87	115	124	143	168
			%	0,1	0,1	0,1	0,1	0,1	0,1	0,1	0,1
Yearly energy consumption	QHE		GJ	71	91	117	141	-	-	-	-
Noise (sound power level)	LWA	at max P	dB(A)	51	52	53	54	55	56	57	57
Emissions (*)	NOx	(referred to HCV)	mg/kWh	42,0	43,9	34,2	36,4	38,1	38,7	39,3	46,1
Emissions at max/min heat input (G20)	CO2		%	9 - 9	9 - 9	9 - 9	9 - 9	9 - 9	9 - 9	9 - 9	9 - 9
	CO		ppm	63/2,3	73/2,3	79/6,5	90/6,5	81/7,5	91,5/7,5	89/4,6	91,5/5,6
Maximum nominal heat input (LCV)	G25		kW	35	50	53	65	85	93	107	127
Minimum nominal heat input (LCV)	G25		kW	9	9	13	13	18,1	18,5	21,4	24,5
Emissions at max/min heat input (G25)	CO2		%	9 - 9	9 - 9	9 - 9	9 - 9	9 - 9	9 - 9	9 - 9	9 - 9
	CO		ppm	72/3,2	80/3,2	92/7	93,5/7	84/8	94/8	92/6	95/7
Emissions at max/min heat input (G30)	CO2		%	10,4-9,9	10,4-9,9	10,4-10,4	10,4-10,4	10,4-10,4	10,4-10,4	10,4-10,4	10,4-10,4
	CO		ppm	132/6	137/6	138/10	142/10	148/11	159/11	172/13	180/15
Emissions at max/min heat input (G31)	CO2		%	10,4-9,9	10,4-9,9	10,4-10,4	10,4-10,4	10,4-10,4	10,4-10,4	10,4-10,4	10,4-10,4
	CO		ppm	136/8	141/8	142/11	147/11	153/12	163/12	177/14	185/16
Flue gas temperature at max P and min P 80-60°C			°C	66,5/61	67,5/61	71/61	72/61	76/62	78/62	75/61	77/61
Flue gas temperature at max P and min P 50-30°C			°C	44/32	45/32	45/33	46/33	47/35	49/35	45/33	48/35
Flue gas mass airflow (**)			Kg/s	0,015	0,02	0,025	0,03	0,04	0,046	0,05	0,06
Water side resistance (ΔT 20°C)			mbar	-	-	-	-	160	210	350	510
Useful head available (Δ 20°C)			mbar	250	420	490	390	-	-	-	-
Maximum operating pressure			bar	6							
Minimum working pressure			bar	0,7							
Maximum allowed temperature			°C	100							
Blocking thermostat activation temperature			°C	95							
Temperature adjustment range (min / max)			°C	30 / 80							
Heat module water content			l	5	5	15	15	17	17	23	25
Max. condensate production at 100% nominal power (50-30°C)			l/h	5,4	7	8,9	10,1	13,6	15	17,5	19,8
Electrical power supply			V-Hz	230-50							
Electrical protection level			IP	IPX4D							
Electrical power absorbed at full load	Elmax		W	75	105	63	77	150	203	205	302
Electrical power absorbed at partial load	Elmin		W	31	34	30	30	36	31	44	45
Electrical power absorbed in stand-by mode	P sb		W	9	9	13	13	6	6	6	8
Net weight			kg	64	64	64	64	69	69	84	90

** Values referred to the atmospheric pressure above sea level.

** Weight values calculated according to standard EN 15502.

USER INTERFACE



POWER MAX IS EQUIPPED WITH A **MODERN AND USER-FRIENDLY** CONTROL PANEL, PROVIDED WITH A COVER.

THE **INTERFACE** FEATURES A **BACKLIT DISPLAY** WHICH **COMMUNICATES WITH THE USER/INSTALLER** THROUGH **ICONS**, IN A SIMPLE AND INTUITIVE WAY.

CONTROL INTERFACE PRIMARY INFORMATION

- 01 Backlit display
- 02 MENU/RESET key: it allows accessing the main menu and restoring the operation after a stop due to an anomaly
- 03 Navigation keys
- 04 Main switch (located on the equipment lower side)

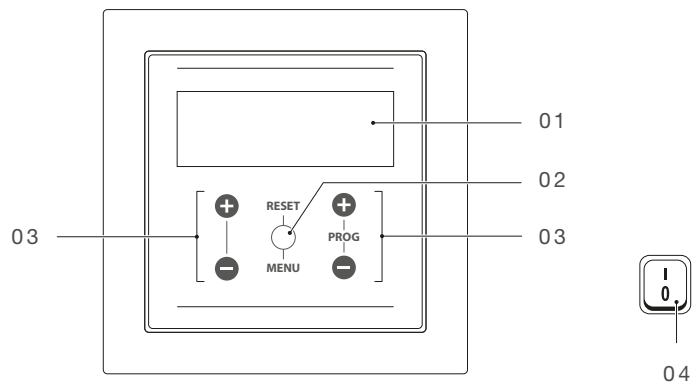

DISPLAY VIEW SECONDARY INFORMATION

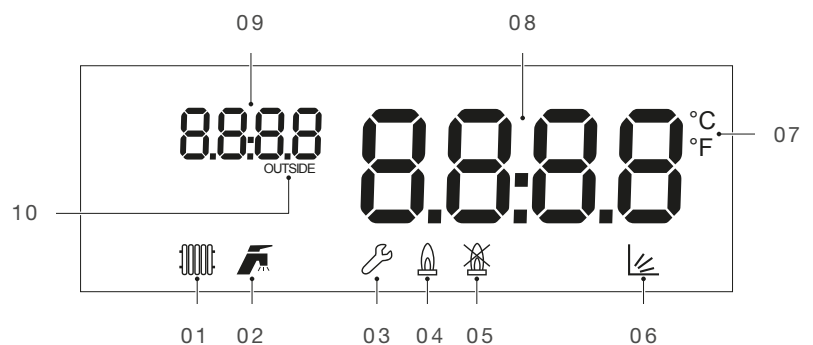

- 01 Icon displayed when the heating mode is enabled. Flashing when there is a heat request
- 02 Icon displayed when the DHW production mode is enabled. Flashing when there is a request for domestic hot water
- 03 Icon displayed when entering the "Installer" or "Manufacturer" menu
- 04 Icon displayed when the burner of the equipment is on
- 05 Icon displayed when a Permanent or Temporary error occurs.
- 06 Icon displayed when the climatic mode operation is active (Par. 2001= 1 or 2)
- 08 Large numeric display: displaying of the current value
- 09 Small numeric display: displaying of system pressure or parameter number
- 10 Icon displayed when the external probe is connected

HYDRAULICS

CIRCULATION PUMPS

The models **POWER MAX 50 P DEP**, **POWER MAX 50 P**, **POWER MAX 65 P** and **POWER MAX 80 P** are equipped with circulation pump.

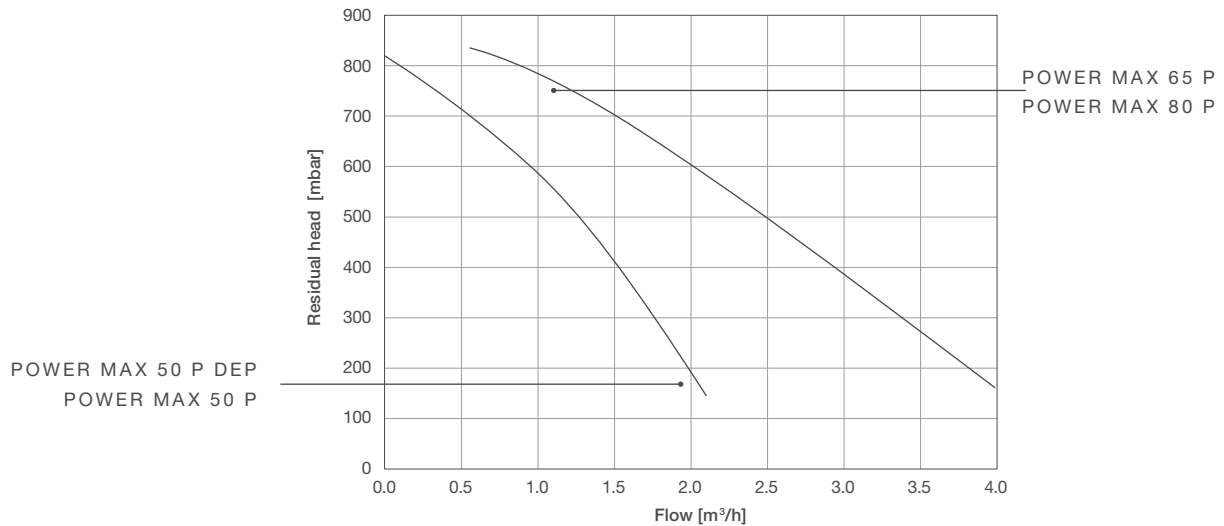

PRESSURE DROPS ON WATER SIDE OF GENERATORS

The models **POWER MAX 100**, **POWER MAX 110**, **POWER MAX 130** and **POWER MAX 150** are not provided with circulation pump, which must be installed inside or outside the equipment. For its dimensioning, consider pressure drops on water side of the heat modules, shown in the diagram below.

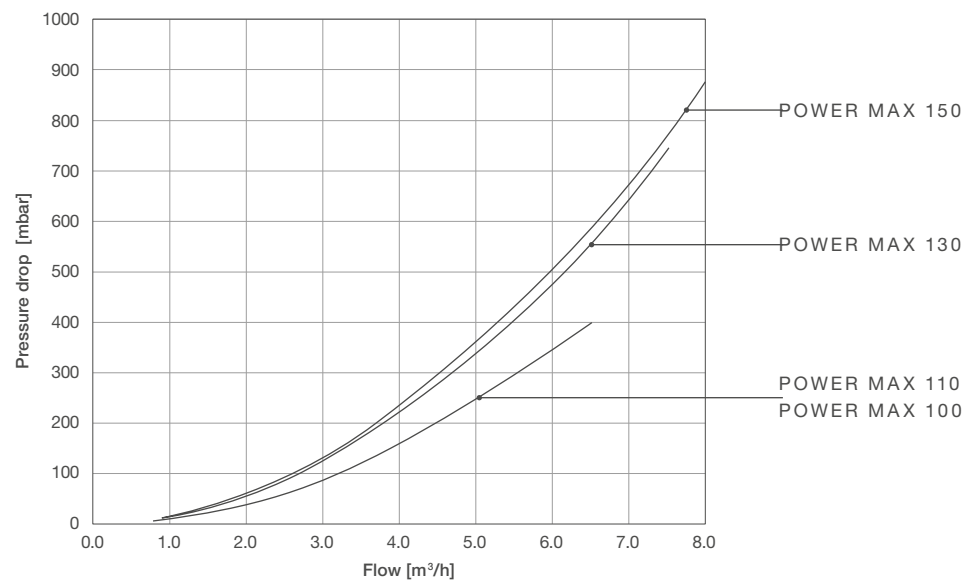

INJECTION PUMP KIT

For the models POWER MAX 100, POWER MAX 110, POWER MAX 130 and POWER MAX 150, which are not provided with circulation pump, pump kits are available, that can be installed inside or outside the equipment. Please find below the characteristic curves of the three circulation pumps

CIRCULATION PUMP THAT CAN BE INSTALLED ON THE MODELS POWER MAX 100, 110 AND 130.

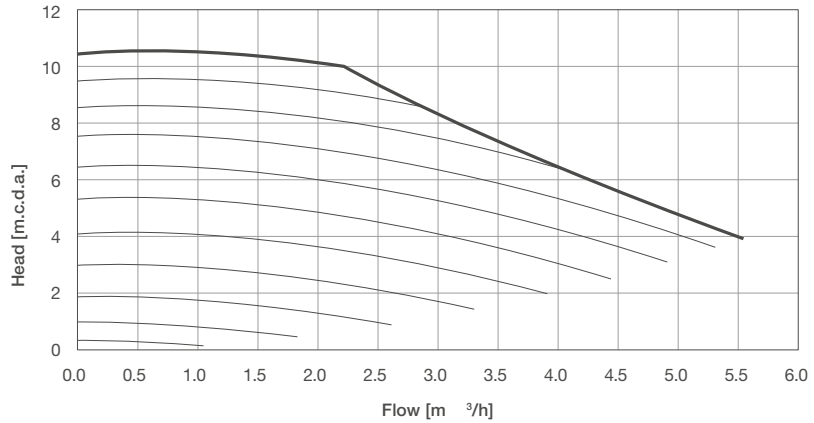

CIRCULATION PUMP THAT CAN BE INSTALLED ON THE MODELS POWER MAX 130 (HIGH HEAD) AND 150 (LOW HEAD ONLY).

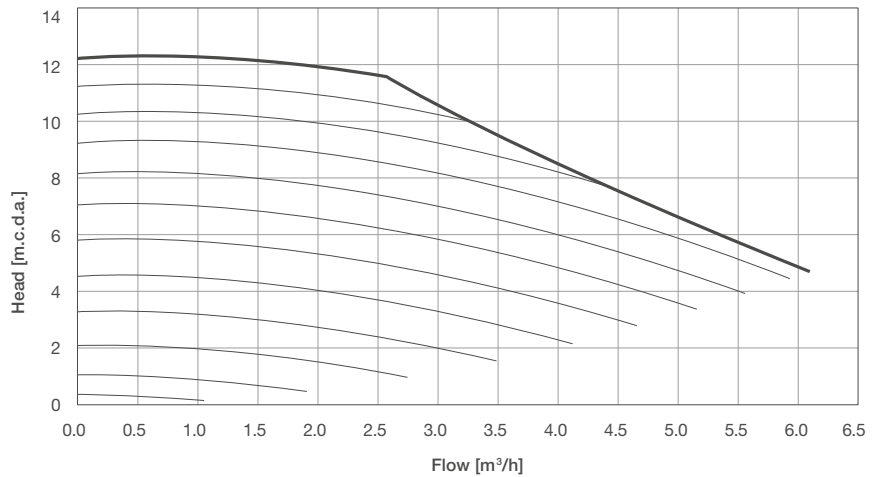

CIRCULATION PUMP THAT CAN BE INSTALLED ONLY ON THE MODEL POWER MAX 150.

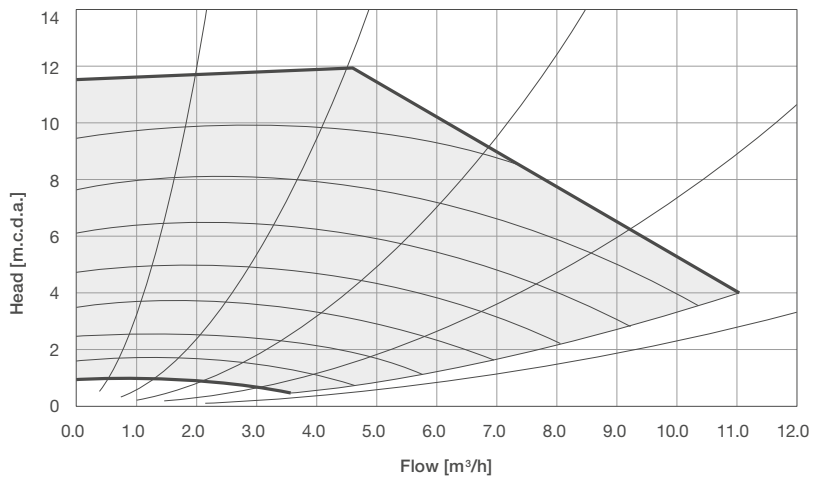

TEN GOOD REASONS TO CHOOSE POWER MAX CASCADE SYSTEMS

MAXIMUM PERFORMANCE IN ANY CONDITION

The modulation of a POWER MAX cascade system is considerably higher than that of a single boiler. In fact, through the control of the number of heat modules in operation, the system optimises the power delivered according to the actual requirements.

In the middle seasons - spring and autumn - when the demand is lower because of the favourable climatic conditions, or in buildings with very variable needs depending on the presences (Hotels and Restaurants), the cascade control will activate only the boilers required, ensuring the necessary power to meet the actual heat needs.

CONTINUITY OF SERVICE WITHOUT CONCERN

POWER MAX cascade systems are much more reliable than monobloc boilers. In case of a unit downtime, the rest of the system is not involved and continues to operate to meet the heat requirements.

BEST CHOICE FOR REPLACEMENT

The modularity of POWER MAX systems is the right solution in case of replacement of central heating systems with difficult access to the plant room: each unit of the cascade can be easily transported and has reduced dimensions and weight.

MAXIMUM COST-EFFECTIVENESS FOR REPLACEMENT

The high efficiency of the system, together with the condensing technology, make POWER MAX system the ideal solution for energy retrofits.

There is no need to wait for the existing boiler to break down, as the cost of replacement pays for itself in a few years thanks to the saving on gas supply.

MAXIMUM RESPECT FOR THE ENVIRONMENT

Heat modules POWER MAX have reached the best NOx emission class (Class 6 according to UNI EN 15502) thanks to the total premix burner with micro flame. Moreover, the cascade system manages the ignition of the burners, activating only those necessary for the current heat requirements, thus reducing CO₂ emissions.

MAXIMUM EASE OF MAINTENANCE

The POWER MAX range is designed for an easy maintenance with direct frontal access to all the internal components. Maintenance of the single module of the cascade system can be carried out even if the other modules are running.

MAXIMUM SPACE OPTIMISATION

The cascade POWER MAX system is designed to take as little space as possible, so as to be suitable for both condominiums and commercial buildings. The compact size of the single module (1000x600x435 mm) and an innovative frame, able to contain more than 1 MW in 2.6 m², allow installation even in small plant rooms.

MAXIMUM FLEXIBILITY

The POWER MAX system is suitable for plant rooms where space is limited: thanks to the wide range of accessory kits, POWER MAX is available for stand-alone wall-mounted application, or for cascade application, with linear or back to back configurations. It is also possible to choose output and configuration according to the requirements and the space available.

MAXIMUM EASE OF INSTALLATION

Cascade heat modules POWER MAX can be easily installed thanks to the large number of accessory kits available. Every single module can be transported separately to the plant room, easily passing through any door. The installer will only have to assemble modules and kits with simple, easy and fast operations.

MAXIMUM MODULATION RANGE AND ELECTRONIC MANAGEMENT SPEED

POWER MAX boilers feature an electronic board able to manage complex systems thanks to the precision of calculation programs and to the processing speed. Thanks to the onboard electronics, with the addition of the accessory kit for flue and hydraulics, it is possible to manage up to 10 modules in cascade, thus reaching a very high modulation ratio.

MAXIMUM APPLICATION FLEXIBILITY

Each model of POWER MAX can be installed in **cascade** with up to 10 modules, except for POWER MAX 150 that can be configured with up to 8 modules. Considering the number of linear and back-to-back configurations, POWER MAX range allows implementing 140 types of cascade configurations, which added to the single applications of the various models reaches

148 applications.

The number increases significantly if we add plate heat exchangers and hydraulic separators as accessory kits to these configurations. This adaptability allows POWER MAX to stand out in the reference scenario of high power boilers, a plus that is increasingly appreciated also in the plant room.

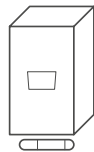

STAND-ALONE CONFIGURATIONS

8

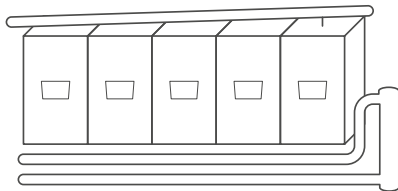

LINEAR CASCADE CONFIGURATIONS

70

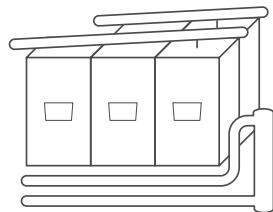

BACK-TO-BACK CASCADE CONFIGURATIONS

70

OUTPUT RANGE FOR CASCADE APPLICATIONS

Summary table of output range for each model in cascade application

- POWER MAX 50 P DEP**
(2-10 PCS)
- POWER MAX 50 P**
(2-10 PCS)
- POWER MAX 65 P**
(2-10 PCS)
- POWER MAX 80 P**
(2-10 PCS)
- POWER MAX 100**
(2-10 PCS)
- POWER MAX 110**
(2-10 PCS)
- POWER MAX 130**
(2-10 PCS)
- POWER MAX 150**
(2-8 PCS)

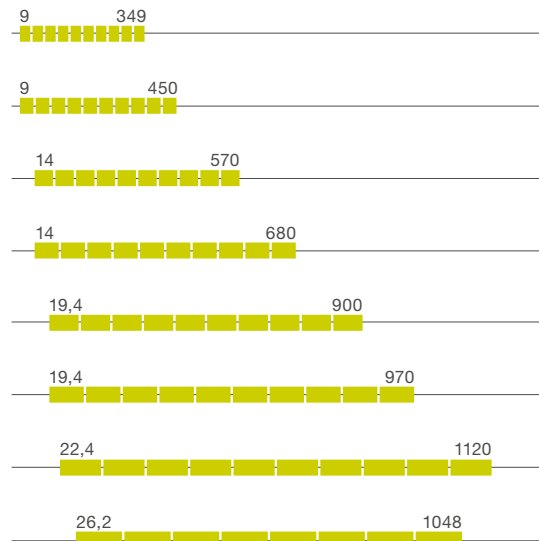

POWER MAX, CASCADE DIMENSIONS

LINEAR CASCADE APPLICATIONS

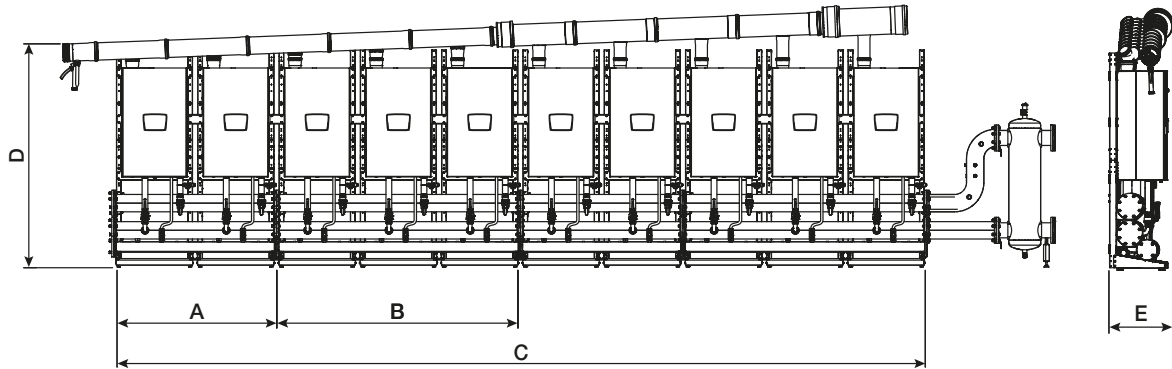

Description		50 P DEP	50 P	65 P	80 P	100	110	130	150
A	mm	1494	1494	1494	1494	1494	1494	1494	1494
B	mm	2242	2242	2242	2242	2242	2242	2242	2242
C (10 units)	mm	7472	7472	7472	7472	7472	7472	7472	5978 (max 8 units)
D	mm	2051	2051	2051	2051	2051	2051	2221	2221
E	mm	525	525	525	525	525	525	525	525

BACK-TO-BACK CASCADE APPLICATIONS

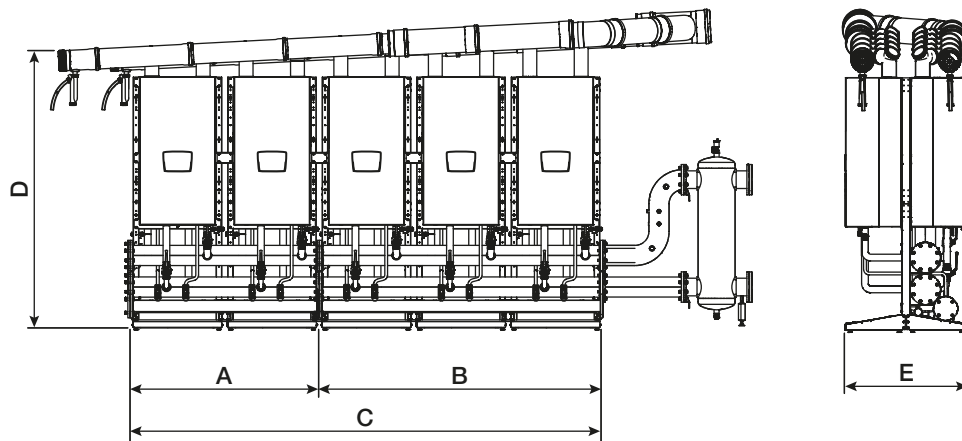

Description +		50 P DEP	50 P	65 P	80 P	100	110	130	150
A	mm	1494	1494	1494	1494	1494	1494	1494	1494
B	mm	2242	2242	2242	2242	2242	2242	2242	2242
C (5+5 units)	mm	3740	3740	3740	3740	3740	3740	3740	2988 (max 4+4 units)
D	mm	2051	2051	2051	2051	2051	2051	2221	2221
E	mm	970	970	970	970	970	970	970	970

REMOTE CONTROL KIT AND MANAGEMENT OF ADDITIONAL ZONES

The remote control kit is an accessory that allows the hourly management of the generator and of any additional zones to which the additional 'Electronic zone management kit' must be matched. The remote control is absolutely essential in case of systems that communicate through MODBUS protocol.

CONTROL INTERFACE

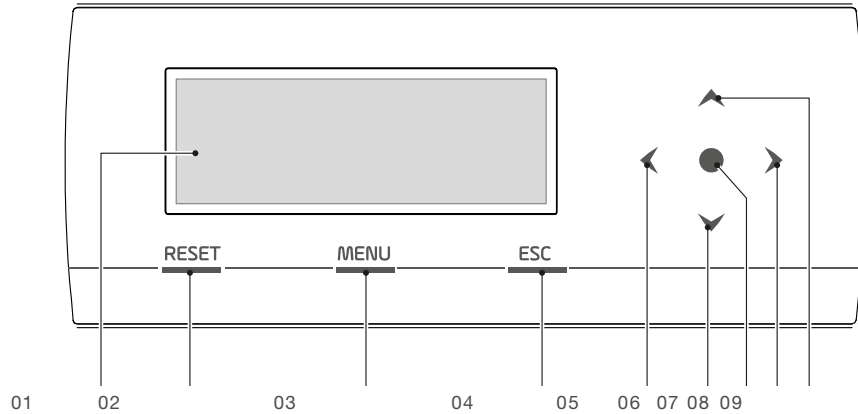

KEY

- 01 Backlit display, 255x80 pixels (106.4x39.0mm)
- 02 RESET key: it allows resetting the operation after a stop due to an anomaly
- 03 MENU key: it allows accessing the main menu
- 04 ESC key: in the menu navigation it allows exiting a menu item and go back to the previous one
- 05/09 Navigation keys ◀, ▼, •, ▶, ▲

ELECTRONIC ADDITIONAL ZONE MANAGEMENT KIT

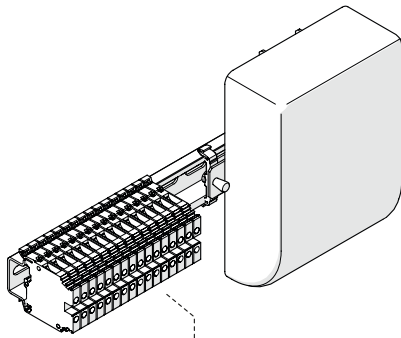

This accessory for additional zone management must be positioned outside the generator, on the DIN bar placed inside the electrical panel. It is provided with all the inputs and outputs to control a mixed system. For its correct operation it is mandatory to provide for the temperature probe for mixed system.

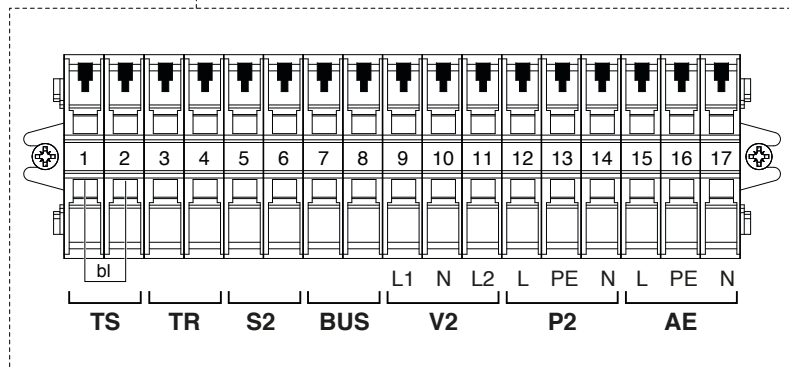

KEY

- TS Safety thermostat
- TR Setting thermostat (zone)
- S2 Flow probe (zone)
- BUS Board bus
- V2 Mixing valve (zone)
- P2 Zone circulation pump



Trading Address:

Via Risorgimento, 23/A
23900 LECCO (LC) Italy
Tel. +39 0341 277111
Fax +39 0341 277263
www.berettaheating.com

In order to improve its products, Beretta reserves the right to modify the characteristics and information contained in this catalogue at any time and without prior notice. This catalogue, therefore, cannot be considered as contractually binding on third parties.

 **Beretta**