

# PRODUCT CATALOGUE

09 | 2025

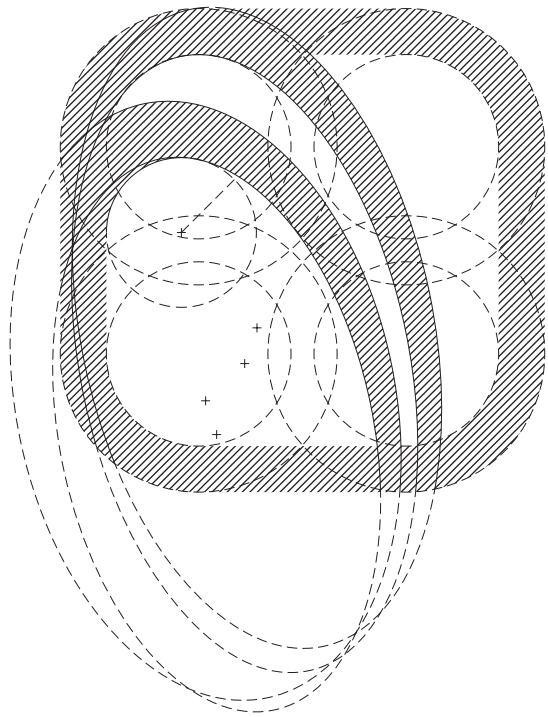



The experts in residential heating  
for over fifty years.  
Excellence and innovation for the  
comfort of millions of homes,  
in Italy and in the world.

# BERETTA TODAY

## BERETTA

The Specialist in residential heating for over fifty years: excellence and innovation, for the comfort within millions of homes. Today Beretta confirms its growing trend in the residential heating and faces new challenges with the same enthusiasm and the same commitment of the beginnings. Because the excellence in the products and in the supplied services remain Beretta's key values.

## EXCELLENCE

The great expertise gained over the years in the field of residential heating has made of Beretta one of the reference brands of its sector. Today, as in the beginnings, the pursuit of excellence in every activity and, more specifically, the constant attention to product and services represent Beretta core values.

## RESIDENTIAL HEATING

Specialist in residential heating systems: this is the product mission. Beretta anticipates changes without compromising its vocation as reference brand in this sector. A targeted expertise, honed and sustained over time. In this way, the Company responds to the different plant engineering needs, thanks to the know-how gained in over fifty years of experience in the sector, and is constantly committed to expanding its offer of products and services. New technologies and new solutions that can integrate, in a highly efficient way, different energy sources, giving priority to renewable energy.

## EFFICIENCY

With a strong focus on residential heating, Beretta product portfolio concentrates increasingly on solutions that enhance energy efficiency through the intelligent integration of different energy sources.

## TECHNOLOGY

Beretta has always shown an exceptional ability to foresee change and respond to the resulting evolutions in demand. Two examples of many past cases: Beretta was the first Italian company to produce a wall-hung gas boiler and - with the IDRA METEO model, the first to produce a wall-hung boiler specifically designed for outdoor installation. A commitment to innovation which today increasingly takes an environmental slant, with a view to excellence and cutting-edge technology. Beretta solutions target improved energy efficiency and the reduction of emissions, both for the sustainability of the environment and to ensure all the comfort that millions of consumers are accustomed to demanding and receiving from Beretta products

## TERRITORY

Beretta customer-centred approach translates into a network of specialists: proximity, expertise, flexibility are Beretta key values. Beretta, after over fifty years since the production of its first wall-hung gas boiler, is nowadays a worldwide known brand in the field of home heating solutions, synonymous with technology and quality. Our products are sold through Subsidiaries, Sales Partners and OEM Customers in over 30 countries.

## ATTENTION TO ENVIRONMENT

Beretta commitment is concrete and aims at an increasingly sustainable future. For years, Beretta has been committed to a system logic which combines the intelligent use of several sustainable and renewable energy sources, in perfect harmony with the environment around us, for the home comfort of millions of consumers who use Beretta products every day.



## BERETTA WORLDWIDE PRESENCE

BERETTA, **AFTER OVER FIFTY YEARS** SINCE THE PRODUCTION OF ITS FIRST WALL-HUNG GAS BOILER, IS **NOWADAYS A WORLDWIDE KNOWN BRAND IN THE FIELD OF HOME HEATING**, SYNONYMOUS WITH TECHNOLOGY AND QUALITY.



## CONSOLIDATED **KNOW-HOW** AT YOUR SERVICE



---

### **AFTER-SALES SERVICE**

BERETTA PUTS A GREAT DEAL OF EMPHASIS ON AFTER-SALES SERVICE, WITH A CENTRAL TECHNICAL SERVICE TEAM COMMITTED TO SUPPORTING OUR SUBSIDIARIES AND SALES PARTNERS TO PROVIDE LOCALLY A QUALIFIED SERVICE. WHEREVER YOU BUY A BERETTA PRODUCT IN THE WORLD, YOU ARE IN SAFE HANDS.



---

### **PRE-SALES SERVICE**

THE BERETTA PRE-SALES SERVICE TEAM, THANKS TO THE CONSOLIDATED KNOW-HOW, GIVES ADVICE ON THE WHOLE PORTFOLIO OF PRODUCTS TO OUR SALES PARTNERS AND SUBSIDIARIES IN THE WORLD, SO THAT THEY CAN LOCALLY SUPPORT ENGINEERS, ARCHITECTS, SPECIFIERS AND DEVELOPERS IN CHOOSING THE BEST SOLUTION FOR THEIR PROJECTS.



---

### **ORIGINAL SPARE-PARTS AND ACCESSORIES**

FOR YOUR COMPLETE PEACE OF MIND, THE BERETTA ORIGINAL SPARE PARTS AND ACCESSORIES ARE AVAILABLE AT OUR SALES PARTNERS AND SUBSIDIARIES ALL OVER THE WORLD.

---

# TECHNICAL TRAINING

All Beretta Sales Partners and Subsidiaries in the world organize technical training courses, focusing on the need of the installer and engineer to become familiar with Beretta products and to enable quick and simple installation or repair.

Our technical training is structured to cover the appliance range, installation, operation, wiring, flueing, benchmark, fault finding and commissioning.



**LECCO - ITALY**

**ATENEO**

OVER 400 sq.m  
DEDICATED  
TO SPECIALISED  
TRAINING



**BUCAREST - ROMANIA**



**BARCELONA - SPAIN**

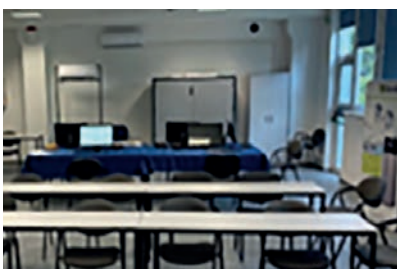

**TORUN - POLAND**



FACTORY MADE,  
HIGH EFFICIENCY  
MULTI-ENERGY  
SYSTEM



ADVANCED  
ENERGY MANAGER  
FOR SMART  
MANAGEMENT OF  
ENERGY SOURCES



AVAILABILITY  
OF ECONOMIC  
OPTIMIZATION  
MODE



HIGH DOMESTIC  
HOT WATER  
COMFORT



LOW NOISE  
OPERATION



SIGNATURE  
COMPACT SYSTEM  
DESIGN



IDEAL FOR  
REPLACEMENT AND  
RENOVATION



ADD-ON  
MODULARITY  
FOR SYSTEM  
INTEGRATION

HIGHLIGHTS

# HARMONY HYBRID

## A SYSTEM IN PERFECT HARMONY



CIAO X  
WALL-HUNG  
CONDENSING BOILER

Hi, Comfort T300-HY  
ENERGY MANAGER



HYBRID HYDRAULIC KIT  
INDOOR UNIT HEAT PUMP



NEW

**BERETTA HARMONY**  
OUTDOOR UNIT HEAT PUMP



Beretta introduces HARMONY HYBRID, a new generation of residential hybrid systems designed to place the user at the heart of energy management. In fact, **thanks to the Energy Manager and its proprietary algorithm, the system allows the gas boiler and heat pump to operate simultaneously**, optimizing their mix according to the desired operation profile, that can be selected by the user either through the Energy Manager or via the App **Hi, Comfort**.

**HARMONY WITH YOUR RESOURCES**

Hybrid technology is widely known for its environmental and energy-saving benefits, but the high upfront cost often discourages buyers. **HARMONY HYBRID was designed with affordability** in mind, offering a cost-effective solution in its segment. **In addition, thanks to its smart energy management via a dedicated economic mode, that can be selected by the user, it helps reduce operating costs over time without compromising comfort - making HARMONY HYBRID a worry-free choice.**

**HARMONY WITH YOUR LIVING SPACE**

The compact design of the system's components, along with its installation flexibility and modularity, makes **HARMONY HYBRID perfectly suited for a wide range of residential settings - even smaller spaces** - whether for replacement or energy retrofit projects.

**HARMONY WITH THE ENVIRONMENT**

HARMONY HYBRID is a hybrid solution that uses energy sources responsibly, optimizing energy consumption. Moreover, by activating the **dedicated "eco-optimization" mode, the system can also operate in a way that significantly reduces CO<sub>2</sub> emissions into the environment.**



**HARMONY HYBRID is Smart Grid Ready:** designed to operate in synergy with modern intelligent energy distribution networks.

HIGHLIGHTS

# EXCLUSIVE EVO X

## THE NEXT LEVEL OF EXCLUSIVE



EXCLUSIVE EVO X achieves class A+ (\*) system in combination with the Hi, Comfort T100 or Hi, Comfort T300 smart controls, available as accessories.

(\*) The efficiency class range of this product category in a system is between G and A+++ in heating.

Beretta introduces EXCLUSIVE EVO X, the new condensing boiler which represents the top of the range of its offerings in terms of performance and efficiency. The “flagship” of Beretta, featuring a stylish and modern design with its full touch control panel, stands out for the wide modulation range 1:13, the condensing heat exchanger with a new adaptive combustion control, the excellent DHW comfort and a very quiet operation.

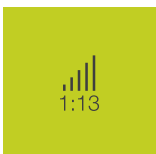

WIDE MODULATION RANGE 1:13



HIGH PERFORMANCE

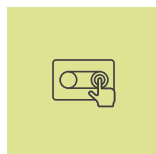

ADVANCED FULL TOUCH INTERFACE



EXCELLENT DHW COMFORT

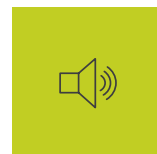

VERY QUIET OPERATION

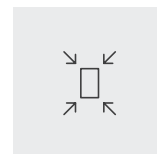

STYLISH AND COMPACT DESIGN

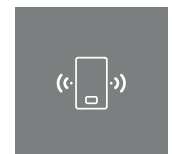

IOT READY

# MYNUTE BOILER EVO X

NEW

## PLENTY OF HOT WATER AT YOUR FINGERTIPS

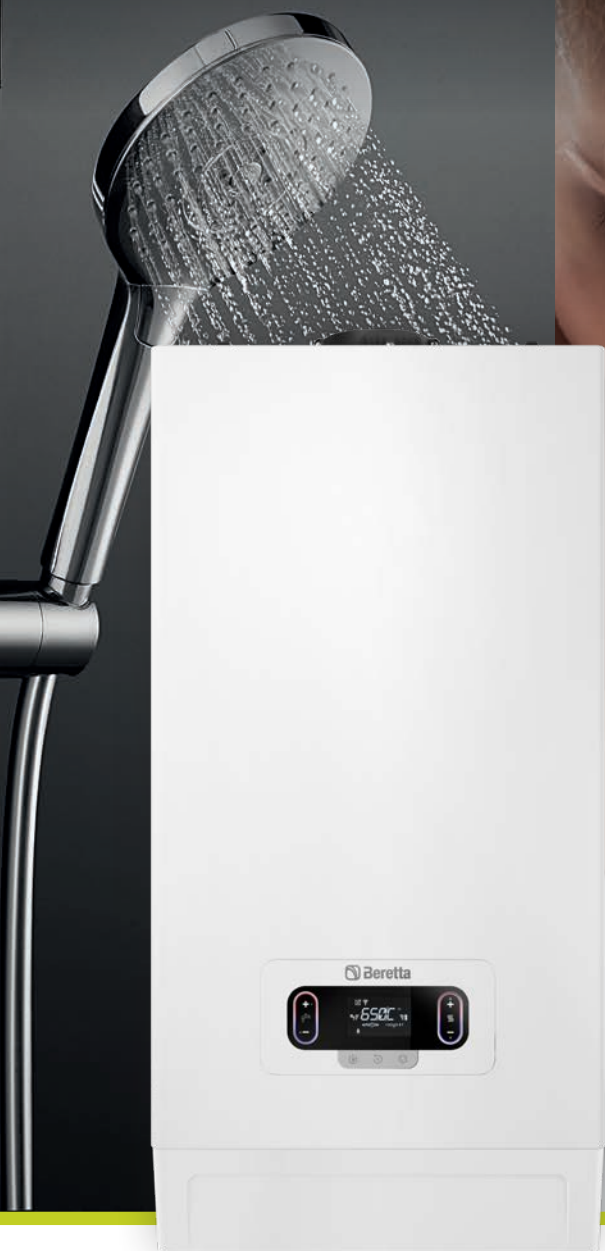

Beretta introduces MYNUTE BOILER EVO X, the new condensing boiler with a 30-litre DHW bi-tank, offering uncompromising DHW comfort. The new product represents an important evolution from the previous ranges with built-in tank. More compact and efficient, it features a stainless steel heat exchanger with pneumatic combustion and a wide 1:10 modulation, for high heating comfort. MYNUTE BOILER EVO X, consisting of the boiler itself and the bi-tank, stands out with its easy installation in two steps: mounting of the bi-tank on the wall and mounting the boiler on the tank.

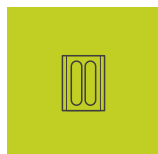

30 L  
STAINLESS STEEL  
BI-TANK



STAINLESS STEEL  
HEAT EXCHANGER



HOT WATER  
AT A STABLE  
TEMPERATURE



LOW NOX EMISSIONS  
(CLASS 6)

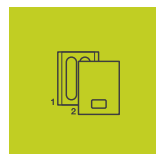

EASY  
INSTALLATION  
IN TWO STEPS

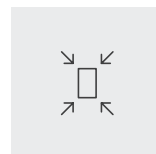

COMPACT  
DIMENSIONS

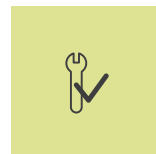

SIMPLIFIED  
MAINTENANCE WITH  
FRONT ACCESS

HIGHLIGHTS

# MYNUTE EVO X

## INNOVATION AND EFFICIENCY, FOR A NEW STANDARD OF COMFORT

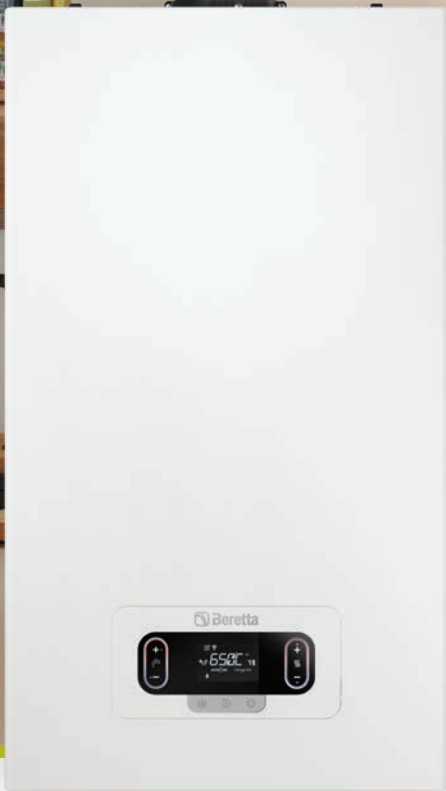

**archiproducts**  
AWARDS  
2023 WINNER

**archiproducts**  
AWARDS  
2023 WINNER  
SUSTAINABILITY

MYNUTE EVO X won the Archiproducts Awards 2023, by gaining appreciation for its project concept and design, and the Archiproducts Awards 2023 SUSTAINABILITY.

MYNUTE EVO X is the latest evolution of MYNUTE, one of the most representative wall-hung boiler families of Beretta in terms of reliability and performance. Common denominator of the entire range is the technological research aimed at energy saving, while offering high comfort and efficiency, in the respect of the environment. Its aesthetic lines, conveying a modern and advanced character, together with the compact dimensions, allow MYNUTE EVO X to harmonize easily in different residential settings, both in replacement and in the new building.



**HIGH  
PERFORMANCE**

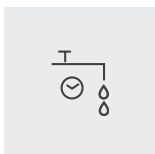

**HIGH DHW  
COMFORT**

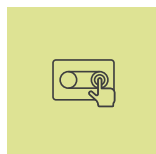

**NEW DIGITAL  
TOUCHPAD  
INTERFACE**

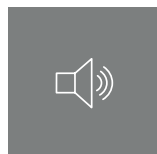

**QUIET  
OPERATION**

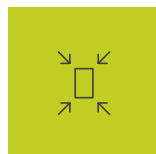

**COMPACT  
DESIGN**



**EASY  
INSTALLATION AND  
MAINTENANCE**

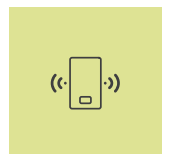

**IOT  
READY**

# CIAO X

## THE COMFORT YOU DESERVE



CIAO X is the new range of Beretta condensing boilers that expertly combines technology and respect for the environment, to offer you the comfort you desire. Touchscreen interface, stainless steel core, easy use and installation make CIAO X the perfect choice both for new buildings and replacement.



**NEW DIGITAL TOUCHPAD INTERFACE**



**HIGH EFFICIENCY**



**QUICK AND STABLE HOT WATER**



**STAINLESS STEEL HEAT EXCHANGER**

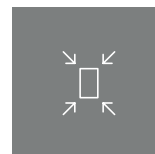

**COMPACT DESIGN**

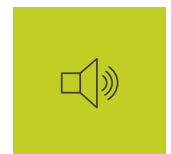

**LOW NOISE OPERATION**

HIGHLIGHTS

# TOWER GREEN M

NEW

## THE NEW RANGE OF ALL-IN-ONE AIR-TO-WATER HEAT PUMPS

**TOWER GREEN M split heat pumps are designed to provide heating, cooling and domestic hot water.**

Available in 10 different power sizes, they offer a wide range of single-phase (4 to 16 kW) and three-phase (12 to 16 kW) models. Thanks to the compressor's DC Inverter technology, they can reach a heating temperature of up to 65°C.

On-board control as standard allows the management of various functions.

TOWER GREEN M heat pumps reach up to class A+++\* (A7; W35°C) in heating and class A+\*\* for domestic hot water.

TOWER GREEN M are suitable to be integrated into a hybrid system, in combination with a gas heating source.

\* The range of energy efficiency class of this product category is between D and A+++

\*\* The range of energy efficiency class of this product category is between F and A+

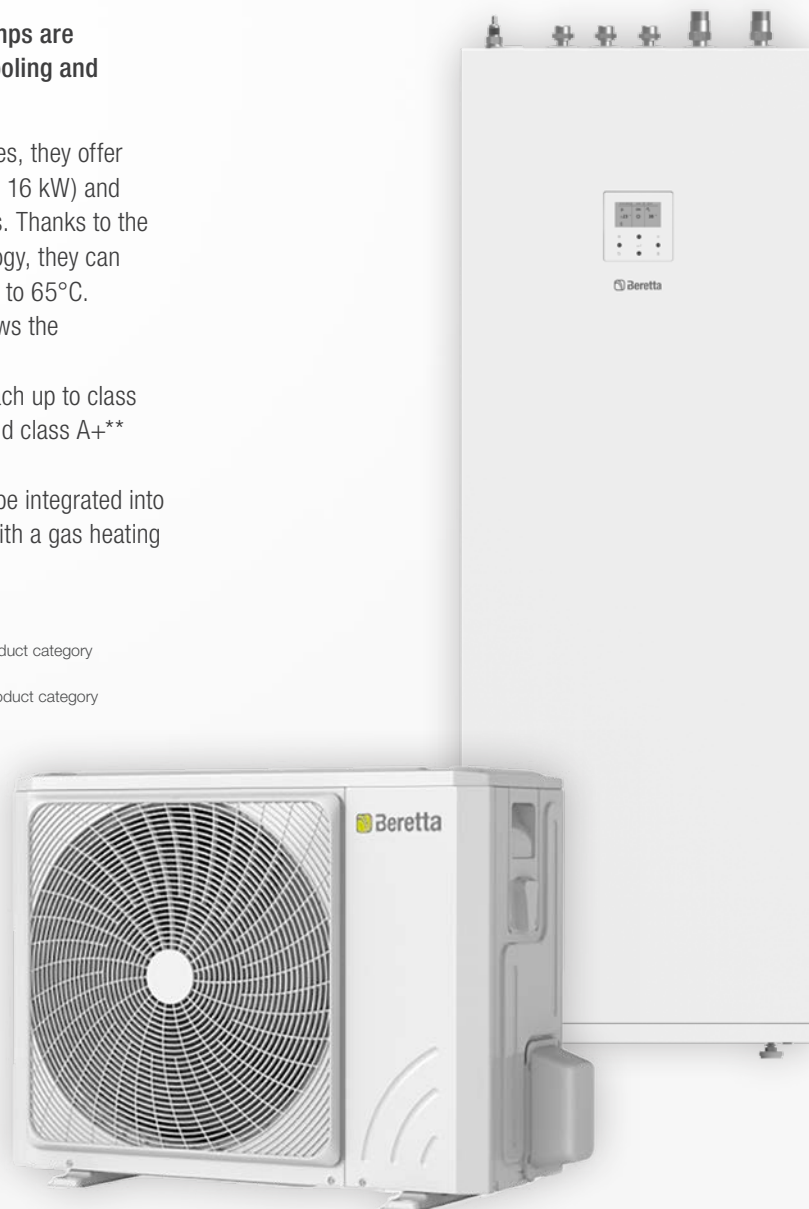

ALL-SEASONS  
COMFORT



EFFICIENT  
PERFORMANCE

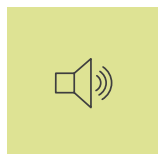

SILENT  
OPERATION

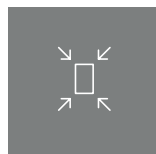

COMPACT  
DIMENSIONS



REFRIGERANT GAS  
R32



WIDE  
RANGE

# POWER EVO X

## THE MODULAR AND COMPACT SOLUTION FOR THE PLANT ROOM

**POWER EVO X is a modular wall hung condensing boiler, which represents the ideal solution for the replacement of old generators in all situations where limited space is a critical issue.**

The range consists of 4 condensing models from 35 to 70 kW, with the possibility of stand-alone and cascade installation up to a maximum of 4 thermal modules, both in in-line and back-to-back configurations, reaching up to 280 kW of power. The range is suitable for indoor or partially protected installation (IPX5D) and is equipped as standard with low-consumption modulating circulators.

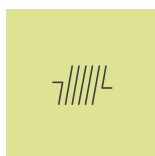

**STAINLESS  
STEEL HEAT  
EXCHANGER**



**ENERGY  
SAVING**



**WIDE RANGE OF  
ACCESSORIES**



**STAND ALONE  
CONFIGURATION**

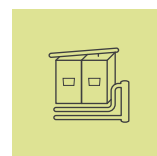

**LINEAR  
CASCADE  
CONFIGURATION**



**BACK-TO BACK  
CASCADE  
CONFIGURATION**

INDEX





# INDEX



## HYBRID SYSTEMS 18

### HYBRID SYSTEMS WITH MONOBLOC HEAT PUMP 21

<b>WALL - HUNG SOLUTIONS</b>	<b>21</b>
Hybrid systems for hybrid ready combined boiler.....	21
Monobloc wall-hung hybrid system MAX .....	43
<b>FLOOR STANDING SOLUTIONS</b>	<b>56</b>
Tower Green HE Hybrid .....	56

### HYBRID SYSTEMS WITH SPLIT HEAT PUMP 60

<b>WALL - HUNG SOLUTIONS</b>	<b>60</b>
Beretta Harmony Hybrid .....	60
RES B COMBI wall - hung split hybrid system .....	64
RES B HEATING-ONLY wall-hung split hybrid system.....	72

## HEAT PUMPS 80

### HEAT PUMPS 82

<b>AIR TO WATER - MONOBLOC</b>	<b>82</b>
Hydro Unit P 004-014.....	82
Hydro Unit M 004-016.....	84
Hydro Unit M 018-030T.....	86
<b>AIR TO WATER - SPLIT</b>	<b>88</b>
Exclusive Agile.....	88
Tower Green M.....	92

## WALL HUNG BOILERS 96

### CONDENSING WALL-HUNG BOILERS 103

<b>INDOOR</b>	<b>103</b>
Exclusive EVO X.....	103
Mynute Evo X.....	108
Mynute Boiler Evo X.....	113
Ciao X.....	118
BLR.....	121
Meteo X.....	124

### STANDARD-EFFICIENCY WALL-HUNG BOILERS 127

<b>INDOOR</b>	<b>127</b>
Exclusive Mix .....	127
Mynute Lx - Mynute S.....	129
Ciao S .....	132
City .....	134
Quadra II Lx - Quadra II.....	137
Ciao Lx - Ciao.....	139
Ciao.....	142

### SYSTEM COMPLEMENTARY ITEMS 144

<b>IDARULIC DISTRIBUTION MODULES</b>	<b>144</b>
Connect Hybrid.....	144
Connect.....	146

<b>FOR STANDARD-EFFICIENCY</b>	<b>159</b>
Flue Option for Standard-Efficiency .....	159

### FLUE OPTION SYSTEMS 164

<b>FOR CONDENSING</b>	<b>164</b>
Flue Option for Condensing .....	164

## WATER-HEATERS 166

### HEAT PUMPS 168

<b>WALL MOUNTED</b>	<b>168</b>
Acquazenit.....	168
<b>FLOOR STANDING</b>	<b>170</b>
Hp-N ACS .....	170

### LOW NOX INSTANTANEOUS - GAS 172

<b>CONVENTIONAL FLUE</b>	<b>172</b>
Fonte Lx P .....	172
<b>ROOM SEALED</b>	<b>173</b>
Idrabagno Lx .....	173

### FLUE OPTION SYSTEMS 175

<b>STANDARD EFFICIENCY</b>	<b>175</b>
Flue Option for Standard Efficiency .....	175

## SOLAR THERMAL AND CYLINDERS 182

### SOLAR SYSTEMS 184

<b>FORCED CIRCULATION</b>	<b>184</b>
SCF-25/4B A system.....	184
SCF-20/4B A system.....	188
<b>NATURAL CIRCULATION</b>	<b>193</b>
NB-SOL-A system .....	193
Accessori.....	197

### SOLAR COLLECTORS 198

<b>FLAT PLATE</b>	<b>198</b>
SCF-25/4B A.....	198
SCF-20/4B A.....	202

<b>SOLAR DHW AND STORAGE CYLINDERS</b>	<b>206</b>
<b>DOUBLE COILS DHW CYLINDERS</b>	<b>206</b>
IDRA DS FI .....	206
IDRA DS .....	208
IDRA PLUS DS .....	212
<b>FLANGED AND DOUBLE COILS DHW CYLINDERS</b>	<b>214</b>
IDRA N DS.....	214
<b>SINGLE COIL DHW CYLINDERS</b>	<b>216</b>
IDRA BV .....	216
IDRA C-HP MS.....	218
IDRA HP .....	223
<b>STORAGE CYLINDERS</b>	<b>225</b>
STOR M / STOR.....	225
STOR H.....	227
<b>SOLAR CONTROLS AND PUMP STATIONS</b>	<b>229</b>
<b>COMPLEMENTARY ITEMS</b>	<b>229</b>
CONNECT SOLAR & EVOSOL .....	229
SUN PRO .....	230
<b>HEAT EXCHANGER UNITS</b>	<b>231</b>
SC SUN.....	231
SC ACS.....	233
<b>ACCESSORIES</b>	<b>235</b>
Accessories .....	235

## CENTRALIZED HEATING 238

<b>CONDENSING WALL-HUNG BOILERS</b>	<b>240</b>
Power Evo X.....	240
<b>WALL HUNG MODULAR SYSTEMS</b>	<b>248</b>
<b>INDOOR/OUTDOOR</b>	<b>248</b>
Power Max .....	248
<b>FLOOR MODULAR SYSTEMS</b>	<b>270</b>
<b>INDOOR/OUTDOOR</b>	<b>270</b>
Power Max Box .....	270
<b>FLUE OPTION SYSTEMS</b>	<b>286</b>
<b>FOR CONDENSING</b>	<b>286</b>
For Chimneys Condensing.....	286
Flue Option for Condensing .....	293

## AIR CONDITIONING 304

<b>AIR CONDITIONERS</b>	<b>306</b>
<b>MONOSPLIT</b>	<b>306</b>
Breva E.....	306
<b>MULTISPLIT</b>	<b>308</b>
Breva Dual E.....	308
Breva Trial.....	310
Breva Quadri.....	312

## TERMINAL UNITS 314

<b>FAN COILS</b>	<b>316</b>
<b>WALL-MOUNTED FAN COILS</b>	<b>316</b>
Tivano Wall .....	316
<b>FAN COILS WITH CABINET</b>	<b>319</b>
Tivano - Tivano R.....	319

## SYSTEM COMPLEMENTARY ITEMS 324

<b>THERMOSTAT AND CHRONOTHERMOSTAT</b>	<b>327</b>
<b>THERMOSTAT AND CHRONOTHERMOSTAT</b>	<b>327</b>
Hi, Comfort T300 .....	327
Hi, Comfort T100 Wi-Fi.....	328
Alpha Programmable Digital Room Thermostat.....	330
Alpha Digital Room Thermostat.....	331
<b>HEAT-EXCHANGERS</b>	<b>332</b>
<b>PLATE HEAT-EXCHANGERS</b>	<b>332</b>
SP - Inspectable plate heat exchanger.....	332

HYBRID SYSTEMS



HYBRID SYSTEMS WITH MONOBLOC  
HEAT PUMP 21

HYBRID SYSTEMS WITH SPLIT  
HEAT PUMP 60

# OVERVIEW – HYBRID T300 / T300-HY / T300-I / REC10MHC / REC10I

		BOILER	HEAT PUMP	
T300		EXCLUSIVE EVO X MYNUTE EVO X		HYDRO UNIT P
				HYDRO UNIT M
				EXCLUSIVE AGILE
T300-Hy		CIAO X		BERETTA HARMONY HYBRID <sup>(*)</sup>
T300-I				TOWER GREEN M
REC10MHC		METEO X MYNUTE X BOX CIAO X		HYDRO UNIT P
				HYDRO UNIT M
				EXCLUSIVE AGILE

(\*) Available only in the Hybrid Systems section with split heat pump



# HYBRID SYSTEMS FOR HYBRID READY COMBINED BOILER

HYBRID SYSTEMS



- The HYBRID Systems consisting of combined boiler, solar collectors and Bertetta heat pump form a class A+ system
- Modular thermally autonomous hybrid system
- Suitable for heating, cooling and domestic water
- Management of COMBINED condensing boiler, heat pump and solar thermal unit
- REC10MHC, Hybrid System Management Control, to be installed in the home on the wall or on the boiler
- Three possible configurations (A, B, C) each with 3 kits to manage a different number of zones (1 DIR; 2 DIR; 1HT+1LT):  
 KIT A (HYBRID DS) - for combined boiler and Heat Pump with solar thermal unit connectable to a double-coil heater  
 KIT B (HYBRID MS) - for combined boiler and Heat Pump that can be combined with a single-coil heater  
 KIT C (HYBRID WITHOUT HEATER) - for combined boiler and heat pump without heater
- New under-boiler distribution module (kit) for applications without hydraulic separator

HEAT PUMPS

WALL HUNG BOILERS

WATER-HEATERS

SOLAR THERMAL UNIT AND CYLINDERS



CENTRALIZED HEATING

AIR CONDITIONING

TERMINAL UNITS

SYSTEM COMPLEMENTARY ITEMS

## HYBRID SYSTEMS FOR COMBINED BOILERS

CODE	DESCRIPTION	MANAGEMENT COMFORT <sup>(1)</sup>	MANAGEMENT DHW	MANAGEMENT ZONES
<b>UNDER-BOILER KIT - DISTRIBUTION MODULE WITHOUT SEPARATOR FOR CONNECTION OF MS HEATER AND DHW MANAGEMENT WITH COMBINED BOILER - HEAT PUMP</b>				
20185507	HYBRID UNDER-BOILER SYSTEM 1 DIR <sup>(A)</sup>	hot / cold	⚡  -	1 DIRECT
<b>KIT A (HYBRID DS) - FOR DS HEATER CONNECTION AND DHW MANAGEMENT WITH COMBINED BOILER - HEAT PUMP - SOLAR</b>				
20134957	HYBRID DS 1 DIR - DHW (COMBI-HEAT PUMP-SOLAR)	hot / cold	⚡	1 DIRECT
20134958	HYBRID DS 2 DIR - DHW (COMBI-HEAT PUMP-SOLAR)	hot / cold	⚡	2 DIRECT
20134959	HYBRID DS 1HT/1LT - DHW (COMBI-HEAT PUMP-SOLAR)	hot / cold	⚡	1HT + 1LT
<b>KIT B (HYBRID MS) - FOR MS HEATER CONNECTION AND DHW MANAGEMENT WITH COMBINED BOILER AND HEAT PUMP</b>				
20134960	HYBRID MS 1 DIR - DHW (COMBI-HEAT PUMP)	hot / cold	⚡  -	1 DIRECT
20134961	HYBRID MS 2 DIR - DHW (COMBI-HEAT PUMP)	hot / cold	⚡  -	2 DIRECT
20134962	HYBRID MS 1HT/1LT - DHW (COMBI-HEAT PUMP)	hot / cold	⚡  -	1HT + 1LT
<b>KIT C (HYBRID WITHOUT HEATER) - FOR DHW MANAGEMENT WITH COMBINED BOILER</b>				
20134963	HYBRID 1 DIR COMBI - WITHOUT HEATER	hot / cold	-  -	1 DIRECT
20134964	HYBRID 2 DIR COMBI - WITHOUT HEATER	hot / cold	-  -	2 DIRECT

## HYBRID SYSTEMS FOR HYBRID READY COMBINED BOILER

CODE	DESCRIPTION	MANAGEMENT COMFORT <sup>(1)</sup>	MANAGEMENT DHW	MANAGEMENT ZONES
20134965	HYBRID 1HT/1LT COMBI - WITHOUT HEATER	hot / cold	-  -	1HT + 1LT

Solar thermal unit; Hydronic Unit heat pump; Hybrid Ready combined condensing boiler

To house the Hybrid kits it is necessary to purchase the BOX, also compatible for built-in installation, code 20130808 and, if necessary, the cock kit code 20131752.

The Hybrid kit codes do not include the boiler, solar collector, heat pump, storage cylinder or inertial storage tank: these must be chosen from the codes indicated in the combination tables.

(A) Code consisting of 1 hydraulic module for direct 1-zone hybrid distribution (code 20165227) and 1 outdoor temperature sensor kit with connector (code 1220559). For hybrid system management command (not included in the kit), refer to the "Management commands for hybrid systems" table. Compatible with heat pump up to model 012/012T only. Check whether there is a bypass valve (code 20182807). Add one if necessary.

(1) Comfort management with boiler and heat pump.

### MANAGEMENT COMMANDS FOR HYBRID SYSTEMS

CODE	MODEL
20207834	REC10MHC hybrid system management command <sup>(1)</sup>
20205322	T300 Hi, Comfot Management control

(1) The REC10MHC panel is used to manage the operation of the HYDRO UNIT M heat pump in a hybrid system.

### BOX FOR HYBRID KIT

CODE	MODEL	DIMENSIONS H x W x D (mm)
20130808	Box (also for built-in installation) for CONNECT HYBRID <sup>(2)</sup>	797 x 400 x 160
20131752	Cock kit for CONNECT HYBRID	-

(1) Paintable box.

### COMBINED CONDENSING BOILERS (COMPATIBLE WITH UNDER-BOILER KITS AND KITS A, B AND C)

CODICE MTN <sup>(1)</sup>	MODEL	GAS	DIMENSIONS H x W x D (mm)	HEAT INPUT OF HEAT. / DOMESTIC WATER Min - Max (kW)	DOMESTIC WATER PRODUCTION (l/min-Δt 25°C)	ENERGY EFFICIENCY CLASS	
						(D→A+++)*	(F→A+)*

#### INSTANTANEOUS COMBINED

20206141	EXCLUSIVE EVO X 25C	MTN/GPL <sup>(1)</sup>	740 x 420 x 275	1,90 - 20,00	14,3	A	A
20206142	EXCLUSIVE EVO X 30C	MTN/GPL <sup>(1)</sup>	740 x 420 x 275	2,70 - 25,00	17,2	A	A
20206143	EXCLUSIVE EVO X 35C	MTN/GPL <sup>(1)</sup>	740 x 420 x 275	2,70 - 32,00	20,0	A	A
20205312	MYNUTE EVO X 25 C	MTN/GPL <sup>(1)</sup>	740 x 420 x 275	2,50 - 20,00	14,3	A	A
20205313	MYNUTE EVO X 30 C	MTN/GPL <sup>(1)</sup>	740 x 420 x 275	3,00 - 25,00	17,2	A	A
20205314	MYNUTE EVO X 35 C	MTN/GPL <sup>(1)</sup>	740 x 420 x 275	3,50 - 30,00	20,0	A	A
20197875	CIAO X 25C	MTN	740 x 420 x 275	3,1-20,0/3,1-25,0	14,3	A	A
20197877	CIAO X 25C	GPL	740 x 420 x 275	5,0-20,0/5,0-25,0	14,3	A	A
20197876	CIAO X 30C	MTN	740 x 420 x 275	3,95-25,0/3,95-30,0	17,2	A	A

(\*) HEATING: the energy efficiency class of the products ranges from D up to A+++ / DHW: the energy efficiency class of the products ranges from F up to A+

(1) Boilers in which gas switch-over, thanks to the new ACC combustion system, is carried out through electronic settings.

**SPECIFIC ACCESSORIES FOR CONDENSING BOILERS**

CODE	MODEL	DIMENSIONS H x W x D (mm)
1103289	Built-in BOX GREEN with door <sup>(1)</sup>	1223 x 654 x 255 (+26)
20132005	Wall-mounted hydraulic connections and gas tap kit for combi boilers	-
20133516	Wall-mounted hydraulic connections and heating, gas and DHW taps kit for combi boilers	-
20196582	Rigid ramps for EDILBOX - 25 kW <sup>(2)</sup>	-
20196580	Rigid ramps for BOX GREEN - 25 kW <sup>(2)</sup>	-
20196581	Rigid ramps for BOX GREEN - 30 kW <sup>(2)</sup>	-
20182807	Adjustable bypass valve	-
20191518	Compact polyphosphate doser kit	-
20191517	Compact magnetic filter	-

(1) The front of the BOX (door) protrudes 26 mm from the recessed frame.

(2) The 'RIGID RAMPS' kits must be used in conjunction with the accessories Compact magnetic filter kit cod. 20191517 and Polyphosphate dosing compact kit cod. 20191518.

**BOILER ACCESSORIES**
**ACCESSORIES FOR EXCLUSIVE EVO-X BOILER**

CODE	DESCRIPTION
<b>IN-WALL INSTALLATION</b>	
20161604	In-wall installation unit <sup>(1)</sup>
20191887	Crossbar for in-wall installation
<b>MECHANICAL ACCESSORIES</b>	
20190324	Air Filter <sup>(2)</sup>
20191519	Hydraulic low fittings cover
20209808	Dummy boiler EXCLUSIVE EVO X 25 C
<b>HYDRAULIC ACCESSORIES</b>	
20191518	Compact polyphosphate doser kit
20191517	Compact magnetic filter
20192808	Board BE09 with double multi-function relay <sup>(3)</sup>
20097192	Condensate booster pump kit
20210993	High residual pump 7,5 m
20035644	Solar diverter valve kit for instant wall-hung combined boilers
1220599	Well probe for remote heater (for heating only version)
20133516	Connection kit with heating system, domestic water and gas cocks (for combi models)
20133517	Connection kit with heating system and gas cocks (for heating only models)
20132005	Connection kit with domestic water and gas cocks (for combi models)
20133386	Connection kit with gas cock (for heating only models)
20192806	Flexible fittings for boiler replacement

## HYBRID SYSTEMS FOR HYBRID READY COMBINED BOILER

CODE	DESCRIPTION
<b>COMPLEMENTARY ACCESSORIES</b>	
20191888	Antifreeze heaters -15 °C <sup>(4)</sup>
1220559	External probe kit
1220639	Limit thermostat for low temperature installations
<b>SPECIFIC FLUES</b>	
20217921	Split connection system kit Ø80 mm
20164664	Ø80 mm clapet kit for pressurized collective flues
20164662	Ø80/125 mm concentric clapet kit for pressurized collective flues
20129175	Wall-hung collector Ø60/100 mm
20129176	Telescopic wall-hung collector Ø60/100 mm
20129177	Vertical collector Ø60/100 mm
20129174	Vertical connection stub pipe kit Ø60/100 mm <sup>(5)</sup>
20129172	90° bend kit Ø60/100 mm for boiler start <sup>(6)</sup>
20134830	Adjustable splitter kit from Ø60/100 mm to Ø80/80 mm
20129769	Adaptor kit B23 Ø80 mm
20129768	Splitter device kit B23 Ø80 mm for in-wall installation box
20190475	Compact adjustable splitter device kit from Ø60/100 mm to Ø80/80 mm
<b>ADVANCED ENVIRONMENT CONTROL EXPANSION BOARDS</b>	
20168672	Solar interface kit <sup>(7)</sup>
20132795	First zone management kit (MIX or DIR zone) <sup>(7)(8)</sup>
20132796	Additional zone management kit (MIX or DIR zone) <sup>(7)(8)(9)</sup>
<b>DISTRIBUTION MODULES WITHOUT SEPARATOR</b>	
20130801	CONNECT HYBRID 1D module <sup>(10)(11)</sup>
20130802	CONNECT HYBRID 2D module <sup>(10)(11)</sup>
20130803	CONNECT HYBRID 1D+1M module <sup>(10)(12)</sup>
20130808	In-wall installation box <sup>(13)</sup>
20131752	Taps kit for BAG3 HYBRID system side and heat pump
<b>ACCESSORIES FOR MYNUTE EVO-X BOILER</b>	
CODE	DESCRIPTION
<b>IN-WALL INSTALLATION</b>	
20161604	In-wall installation unit <sup>(1)</sup>
20191887	Crossbar for in-wall installation
<b>MECHANICAL ACCESSORIES</b>	
20190324	Air Filter <sup>(2)</sup>
20191519	Hydraulic low fittings cover
20209805	Dummy boiler MYNUTE EVO X

CODE	DESCRIPTION
<b>HYDRAULIC ACCESSORIES</b>	
20191518	Compact polyphosphate doser kit
20191517	Compact magnetic filter
20192808	Board BE09 with double multi-function relay <sup>(3)</sup>
20097192	Condensate booster pump kit
20210993	High residual pump 7,5 m
20035644	Solar diverter valve kit for instant wall-hung combined boilers
1220599	Well probe for remote heater (for heating only version)
20133516	Connection kit with heating system, domestic water and gas cocks (for combi models)
20133517	Connection kit with heating system and gas cocks (for heating only models)
20132005	Connection kit with domestic water and gas cocks (for combi models)
20133386	Connection kit with gas cock (for heating only models)
20192806	Flexible fittings for boiler replacement
<b>COMPLEMENTARY ACCESSORIES</b>	
20191888	Antifreeze heaters -15 °C <sup>(4)</sup>
1220559	External probe kit
1220639	Limit thermostat for low temperature installations
<b>SPECIFIC FLUES</b>	
20217921	Split connection system kit Ø80 mm
20164664	Ø80 mm clapet kit for pressurized collective flues
20164662	Ø80/125 mm concentric clapet kit for pressurized collective flues
20129175	Wall-hung collector Ø60/100 mm
20129176	Telescopic wall-hung collector Ø60/100 mm
20129177	Vertical collector Ø60/100 mm
20129174	Vertical connection stub pipe kit Ø60/100 mm <sup>(5)</sup>
20129172	90° bend kit Ø60/100 mm for boiler start <sup>(6)</sup>
20134830	Adjustable splitter kit from Ø60/100 mm to Ø80/80 mm
20129769	Adaptor kit B23 Ø80 mm
20129768	Splitter device kit B23 Ø80 mm for in-wall installation box
20190475	Compact adjustable splitter device kit from 60/100 mm to 80/80 mm
<b>ADVANCED ENVIRONMENT CONTROL EXPANSION BOARDS</b>	
20168672	Solar interface kit <sup>(7)</sup>
20132795	First zone management kit (MIX or DIR zone) <sup>(7)(8)(16)</sup>
20132796	Additional zone management kit (MIX or DIR zone) <sup>(7)(8)(9)(16)</sup>
<b>DISTRIBUTION MODULES WITHOUT SEPARATOR</b>	
2013080	CONNECT HYBRID 1D MODULE <sup>(10)(11)</sup>
20130802	CONNECT HYBRID 2D MODULE <sup>(10)(11)</sup>
20130803	CONNECT HYBRID 1D+1M MODULE <sup>(10)(12)</sup>

## HYBRID SYSTEMS FOR HYBRID READY COMBINED BOILER

CODE	DESCRIPTION
20130808	In-wall installation box <sup>(13)</sup>
20131752	Taps kit for BAG3 HYBRID system side and heat pump

### ACCESSORIES FOR CIAO X BOILER

CODE	DESCRIPTION
------	-------------

#### HYDRAULIC ACCESSORIES

20191518	Compact polyphosphate doser kit
20191517	Compact magnetic filter
20189142	High residual pump 7M
20192808	Board BE09 with double multi-function relay <sup>(3)</sup>
20097192	Condensate booster pump kit
20035644	Solar diverter valve kit for instant wall-hung combined boilers
1220599	Well probe for remote heater (for heating only version)
20133516	Connection kit with heating system, domestic water and gas cocks (for combi models)
20133517	Connection kit with heating system and gas cocks (for heating only models)
20132005	Connection kit with domestic water and gas cocks (for combi models)
20133386	Connection kit with gas cock (for heating only models)
20192806	Flexible fittings for boiler replacement

#### MECHANICAL ACCESSORIES

20190324	Air Filter <sup>(2)</sup>
20191519	Hydraulic low fittings cover
20191884	Dummy boiler Ciao X 25C
20191891	Wall mounting frame 1 pc.
20191892	Wall mounting frame 5 pcs.

#### COMPLEMENTARY ACCESSORIES

20191888	Antifreeze heaters -15 °C <sup>(4)</sup>
1220559	External probe kit
1220639	Limit thermostat for low temperature installations
20191520	Building site kit with analogue hydrometer <sup>(14)</sup>

#### FLUES

20164664	Ø80 mm clapet kit for pressurized collective flues
20164662	Ø80/125 mm concentric clapet kit for pressurized collective flues
20129175	Wall-hung collector Ø60/100 mm
20129176	Telescopic wall-hung collector Ø60/100 mm
20129177	Vertical collector Ø60/100 mm
20129174	Vertical connection stub pipe kit Ø60/100 mm <sup>(5)</sup>
20129172	90° bend kit Ø60/100 mm for boiler start <sup>(6)</sup>
20134830	Adjustable splitter kit from Ø60/100 mm to Ø80/80 mm

CODE	DESCRIPTION
20129769	Adaptor kit B23 Ø80 mm
20129768	Splitter device kit B23 Ø80 mm for in-wall installation box
20190475	Compact adjustable splitter device kit from 60/100 mm to 80/80 mm
20129765	Fixed split system kit Ø80 mm
20194628	Ø60/100 mm PP/PPu - Short flue terminal kit <sup>(15)</sup>

(1) Unit supplied with door.

(2) Ideal to avoid introducing impurities from the intake air into the exchanger and burner.

(3) Ideal board for managing additional circulator, alarm remote kit and zone valve.

(4) The antifreeze heater kit protects the DHW circuit from freezing where temperatures fall below 0°C (down to -15°C), using the copper fitting accessory kits (not flexible).

(5) Code necessary for vertical exhaust with flue system. Accessory already included in kit 20129177.

(6) Code necessary for horizontal exhaust with flue system Ø60/100 mm. Accessory already included in kits 20129175 and 20129176.

(7) Pair with Hi, Comfort T300.

(8) Allows you to manage a MIX zone (pump + 3-point mixer valve) or DIR zone (only pump). Not necessary if the Connect Hybrid kit is purchased.

(9) The first zone management kit must always be present. The boiler can manage up to 3 zones in total.

(10) Supplied without built-in Box.

(11) Equipped as standard with limit thermostat for low temperature systems.

(12) Mixed zone equipped as standard with limit thermostat for low temperature systems.

(13) Recessed wall box in galvanised sheet metal (can be painted white). Mandatory with CONNECT HYBRID.

(14) Code necessary for horizontal exhaust with flue system Ø60/100 mm.

(15) Minimum order quantity 50 pcs.

(16) Mandatory accessory when using REC10MHC or T300 for zone management.

## HEAT PUMPS (COMPATIBLE WITH UNDER-BOILER KITS AND KITS A, B AND C)

CODE	MODEL	DIMENSIONS H x W x D (mm)	HEAT. <sup>(1)</sup> /COOL. <sup>(2)</sup> OUTPUT (kW)	ENERGY EFFICIENCY CLASS (D → A+++)*	
				55°C	35°C

### SINGLE-PHASE HEAT PUMPS

20203411	HYDRO UNIT M 004	718 x 1295 x 426	4,20 / 4,50	A <sup>++</sup>	A <sup>+++</sup>
20203413	HYDRO UNIT M 006	718 x 1295 x 426	6,35 / 6,50	A <sup>++</sup>	A <sup>+++</sup>
20203414	HYDRO UNIT M 008	865 x 1385 x 523	8,40 / 8,30	A <sup>++</sup>	A <sup>+++</sup>
20203416	HYDRO UNIT M 010	865 x 1385 x 523	10,00 / 9,90	A <sup>++</sup>	A <sup>+++</sup>
20203656	HYDRO UNIT M 012	865 x 1385 x 523	12,10 / 12,00	A <sup>++</sup>	A <sup>+++</sup>
20203659	HYDRO UNIT M 014	865 x 1385 x 523	14,50 / 13,50	A <sup>++</sup>	A <sup>+++</sup>

### THREE-PHASE HEAT PUMPS

20203672	HYDRO UNIT M 012T	865 x 1385 x 523	12,10 / 12,00	A <sup>++</sup>	A <sup>+++</sup>
20203674	HYDRO UNIT M 014T	865 x 1385 x 523	14,50 / 13,50	A <sup>++</sup>	A <sup>+++</sup>

(\*) HEATING: the range of energy efficiency class of this products category is between D and A+++

(1) Outdoor air d.b. + 7 °C / w.b. + 6 °C, water 30°C - 35°C.

(2) Outdoor air d.b. + 35 °C/w.b. + 24°C, water 23°C - 18°C.

Models that can be used for stand-alone full electric installation with commands supplied as standard, and for hybrid systems in combination with the REC10MHC command (refer to the specific section).

## SOLAR COLLECTORS (FOR KIT A ONLY)

CODE	DESCRIPTION	MODEL
20201328	Sealed solar collector - 2,5 m <sup>2</sup>	SCF-25/4B A
20201335	Sealed solar collector - 2 m <sup>2</sup>	SCF-20/4B A

For bracket codes and glycol refer to the solar thermal section.

## HYBRID SYSTEMS FOR HYBRID READY COMBINED BOILER

### DOUBLE-COIL HEATERS (COMPATIBLE WITH KIT A)

CODE	MODEL	DIMENSIONS H x Ø (mm)	HEATER CAPACITY (litres)	DISPERSION (W)	CLASS
<b>DOUBLE SERPENTINE BOILERS</b>					
20117881	IDRA DS 200 <sup>(1)</sup>	1338 x 604	208 double coil	62	B
20117882	IDRA DS 300 <sup>(1)</sup>	1838 x 604	301 double coil	69	B

(1) Heaters for Hybrid DS Systems. When connected in Hybrid MS Systems, the two coils must be connected in series. Single-coil heaters (compatible with under-boiler kit and kit B)

CODE	MODEL	DIMENSIONS H x Ø (mm)	HEATER CAPACITY (litres)	DISPERSION (W)	CLASS
<b>SINGLE-COIL HEATERS FOR HEAT PUMP</b>					
20117745	IDRA HP 300 <sup>(2)</sup>	1615 x 600	263 single-coil	85	C
20204198	IDRA C-HP 150 MS	1138 x 604	170 single-coil	55	B
20204200	IDRA C-HP 200 MS	1354 x 604	210 single-coil	58	B
20204202	IDRA C-HP 300 MS	1838 x 604	305 single-coil	68	B

(2) Heaters for Hybrid MS Systems.

### ACCESSORIES FOR IDRA HP 300 SINGLE-COIL STORAGE TANKS (COMPATIBLE WITH KIT B)

CODE	DESCRIPTION
4383504	Solar heat exchanger 0,8 m <sup>2</sup> for IDRA HP 300 <sup>(1)</sup>
20203248	Solar heat exchanger 0,8 m <sup>2</sup> for C-HP 150-300
4383270	Single-phase resistance kit 1,5 kW 1 "1/2

(1) The accessory must be ordered together with the base unit (if the latter is not available, the accessory cannot be ordered). It is supplied uninstalled.

### INERTIAL BUFFER TANKS (COMPATIBLE WITH UNDER-BOILER KIT AND KITS A, B AND C)

CODE	DESCRIPTION
20104496	25-litre cylindrical technical tank kii <sup>(1)</sup>
20171999	STOR H 50 - 50-litre inertial buffer tank <sup>(1)</sup>
20142300	STOR H 100 - 100-litre technical hot/cold tank kit <sup>(1)</sup> <sup>(2)</sup>

(1) Provide at least 3,5 litres per kW of heat pump cooling output.

(2) Code with limited availability.

### ACCESSORIES FOR HYBRID SYSTEMS (COMPATIBLE WITH KIT C)

CODE	DESCRIPTION
20165741	Photovoltaic input board kit <sup>(1)</sup>

(1) To be used only if there is no diverting valve kit code 20131755 within the packages. For info about all the accessories available, refer to the specific section.

**KIT A COMPOSITION (HYBRID DS) - FOR MANAGEMENT (\*) OF DS HEATER AND DHW WITH COMBINED BOILER - HEAT PUMP - SOLAR**

CODE	DESCRIPTION	MANAGEMENT COMFORT	MANAGEMENT DHW	MANAGEMENT ZONES
20134957	HYBRID DS 1 DIR - ACS (COMBI-HEAT PUMP-SOLAR)	hot / cold		1 DIRECT
<b>CONSISTING OF:</b>				
20130801	CONNECT HYBRID 1D MODULE			1 pc.
1220559	OUTDOOR TEMPERATURE PROBE KIT WITH CONNECTOR			1 pc.
20131755	DIVERTING VALVE KIT FOR HEATER MANAGEMENT (WITH PHOTOVOLTAIC INPUT)			1 pc.
20035644	SOLAR MIXING DIVERTING VALVE KIT (FOR COMBINED BOILERS)			1 pc.
20116162	CONNECT SOLAR R RETURN-ONLY HYDRAULIC UNIT - 7,5m			1 pc.
20168672	SOLAR THERMAL UNIT INTERFACE KIT			1 pc.
20134958	HYBRID DS 2 DIR - DHW (COMBI-HEAT PUMP-SOLAR)	hot / cold		2 DIRECT
<b>CONSISTING OF:</b>				
20130802	CONNECT HYBRID 2D MODULE			1 pc.
1220559	OUTDOOR TEMPERATURE PROBE KIT WITH CONNECTOR			1 pc.
20131755	DIVERTING VALVE KIT FOR HEATER MANAGEMENT (WITH PHOTOVOLTAIC INPUT)			1 pc.
20035644	SOLAR MIXING DIVERTING VALVE KIT (FOR COMBINED BOILERS)			1 pc.
20116162	CONNECT SOLAR R RETURN-ONLY HYDRAULIC UNIT - 7,5m			1 pc.
20168672	SOLAR THERMAL UNIT INTERFACE KIT			1 pc.
20134959	HYBRID DS 1HT/1LT - DHW (COMBI-HEAT PUMP-SOLAR)	hot / cold		1HT + 1LT
<b>CONSISTING OF:</b>				
20130803	CONNECT HYBRID HT/LT MODULE			1 pc.
1220559	OUTDOOR TEMPERATURE PROBE KIT WITH CONNECTOR			1 pc.
20131755	DIVERTING VALVE KIT FOR HEATER MANAGEMENT (WITH PHOTOVOLTAIC INPUT)			1 pc.
20035644	SOLAR MIXING DIVERTING VALVE KIT (FOR COMBINED BOILERS)			1 pc.
20116162	CONNECT SOLAR R RETURN-ONLY HYDRAULIC UNIT - 7,5m			1 pc.
20168672	SOLAR THERMAL UNIT INTERFACE KIT			1 pc.

Solar thermal unit; Hydronic Unit heat pump; combined condensing boiler

To house the Hybrid kits it is necessary to purchase the BOX for built-in installation, code 20130808 and, if necessary, the cock kit code 20131752.

The Hybrid system codes do not include boiler, solar collector, heat pump, heater and inertial buffer tank: to be chosen from the codes specified in the combination tables.

(\*) Refer to the "Command panels for hybrid systems" table for the system command panel.

## HYBRID DS SYSTEMS: WITH KIT A, COMBINED BOILER, HEAT PUMP, SOLAR - TWO ZONES (1HT + 1LT)

The system is controlled by the REC10MHC hybrid control connected to Connect Hybrid, and the outdoor temperature probe connected to the boiler.

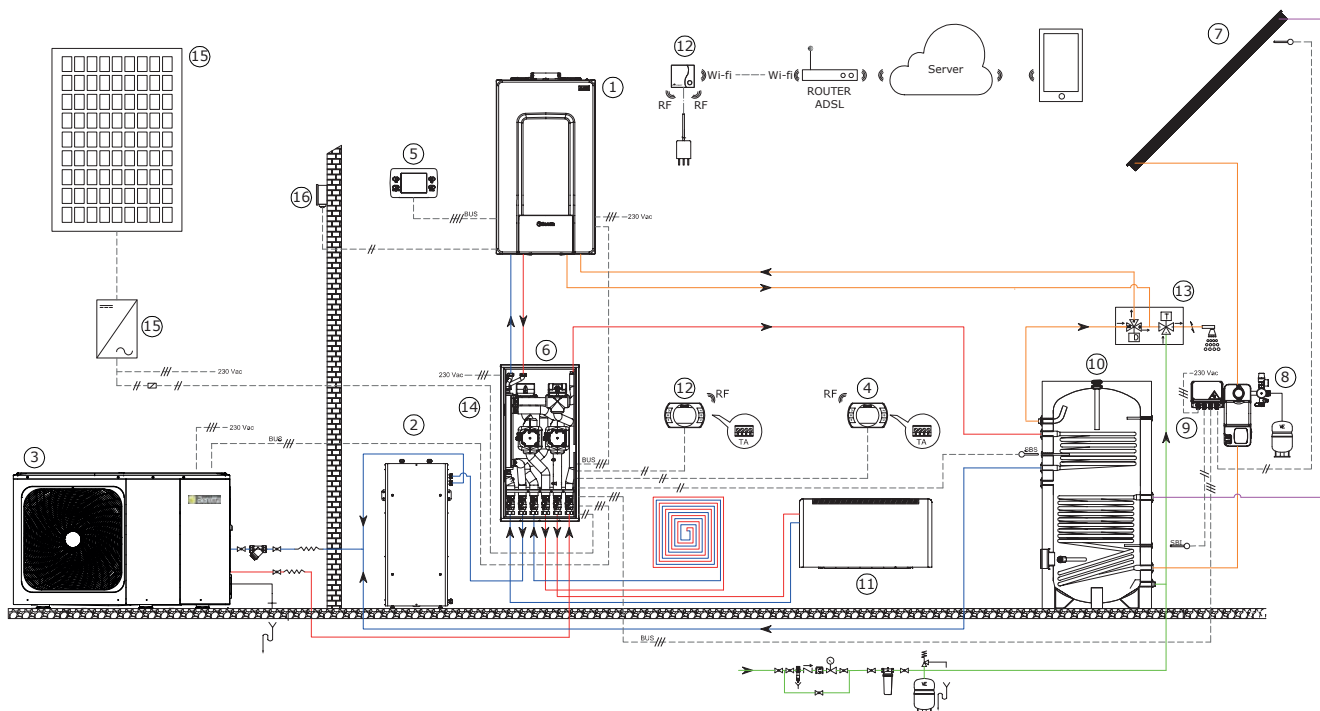

Basic layout purely for illustrative purposes

### KEY:

- (1) Wall hung boiler <sup>(1)</sup>
- (2) STOR H 50 - 50-litre inertial buffer tank
- (3) Heat pump <sup>(1)</sup>
- (4) Hi, Comfort T100 Control
- (5) REC10MHC or T300 hybrid systems management control <sup>(2)</sup>
- (6) Kit A - (Hybrid DS), built into the BOX and with cock kit (optional)
- (7) Solar collector
- (8) Return-only solar hydraulic unit (code sold in kit A - Hybrid DS)
- (9) Solar management board (code sold in kit A - Hybrid DS)
- (10) Double-coil domestic water heater
- (11) Tivano Fan coil
- (12) Wi-fi module
- (13) Diverting/mixing valve (code sold in kit A - Hybrid DS)
- (14) Photovoltaic input board (code sold in kit A - Hybrid DS)
- (15) Photovoltaic string with inverter
- (16) External probe

### Possible solutions\*:

- 1 HT zone or 1 direct LT zone
- 2 HT zones or 2 direct LT zones
- 1 HT zone + 1 LT zone (as per diagram)
- Cooling using TIVANO FAN COIL

(\*) The mixed zone is managed with motorised mixing valves and self-modulating circulating pumps

(1) For more info about combining boilers and heat pumps, refer to the tables in the "GUIDE TO SYSTEM CONFIGURATION" page 68.

(2) The hybrid system management control T300 code 20205322 is necessary to create a wall-mounted hybrid system with the Mynute EVO X and EXCLUSIVE EVO X boilers. Only for boilers with REC10MHC device already installed on the boiler. If it is installed on the wall, the control on the boiler must be disconnected and remotely controlled using a specific accessory. For all configurations, refer to the applicable design and installation standards and to the product's technical manuals.

**KIT B COMPOSITION (HYBRID MS) - FOR MANAGEMENT OF MS HEATER AND DHW WITH COMBINED BOILER AND HEAT PUMP**

CODE	DESCRIPTION	MANAGEMENT COMFORT	MANAGEMENT DHW	MANAGEMENT ZONES
20134960	HYBRID MS 1 DIR - DHW (COMBI-HEAT PUMP)	hot / cold	-	1 DIRECT
<b>CONSISTING OF:</b>				
20130801	CONNECT HYBRID 1D MODULE			1 pc.
1220559	OUTDOOR TEMPERATURE PROBE KIT WITH CONNECTOR			1 pc.
20131755	DIVERTING VALVE KIT FOR HEATER MANAGEMENT (WITH PHOTOVOLTAIC INPUT)			1 pc.
20035644	SOLAR MIXING DIVERTING VALVE KIT (FOR COMBINED BOILERS)			1 pc.
20134961	HYBRID MS 2 DIR - DHW (COMBI-HEAT PUMP)	hot / cold	-	2 DIRECT
<b>CONSISTING OF:</b>				
20130802	CONNECT HYBRID 2D MODULE			1 pc.
1220559	OUTDOOR TEMPERATURE PROBE KIT WITH CONNECTOR			1 pc.
20131755	DIVERTING VALVE KIT FOR HEATER MANAGEMENT (WITH PHOTOVOLTAIC INPUT)			1 pc.
20035644	SOLAR MIXING DIVERTING VALVE KIT (FOR COMBINED BOILERS)			1 pc.
20134962	HYBRID MS 1HT/1LT - DHW (COMBI-HEAT PUMP)	hot / cold	-	1AT + 1BT
<b>CONSISTING OF:</b>				
20130803	CONNECT HYBRID HT/LT MODULE			1 pc.
1220559	OUTDOOR TEMPERATURE PROBE KIT WITH CONNECTOR			1 pc.
20131755	DIVERTING VALVE KIT FOR HEATER MANAGEMENT (WITH PHOTOVOLTAIC INPUT)			1 pc.
20035644	SOLAR MIXING DIVERTING VALVE KIT (FOR COMBINED BOILERS)			1 pc.

Heat pump; Combined condensing boiler.

To house the Hybrid kits it is necessary to purchase the BOX for built-in installation, code 20130808 and, if necessary, the cock kit code 20131752.

The Hybrid system codes do not include the boiler, the hybrid system command panel, the heat pump, storage cylinder or inertial storage tank: these must be chosen from the codes indicated in the combination tables.

(\*) Refer to the "Command panels for hybrid systems" table for the system command panel.

## HYBRID MS SYSTEMS: WITH KIT B, COMBINED BOILER, HEAT PUMP - TWO ZONES (1HT + 1LT)

The system is controlled by the REC10MHC hybrid control connected to Connect Hybrid, and the outdoor temperature probe connected to the boiler.

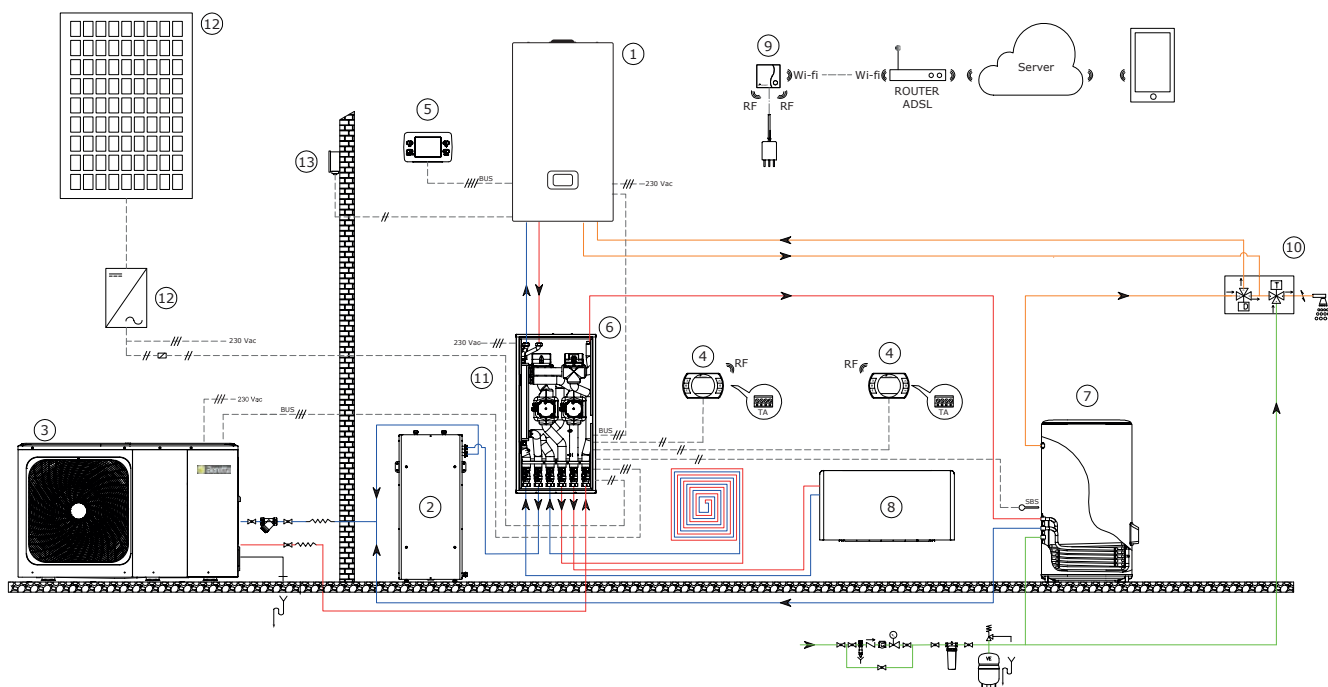

Basic layout purely for illustrative purposes

### KEY:

- (1) Wall hung boiler <sup>(1)</sup>
- (2) STOR H 50 - 50-litre inertial buffer tank
- (3) Heat pump <sup>(1)</sup>
- (4) Hi, Comfort T100 Control
- (5) REC10MHC or T300 hybrid systems management control <sup>(2)</sup>
- (6) Kit B - (Hybrid MS), built into the BOX and with cock kit (optional)
- (7) Single-coil domestic water heater
- (8) Tivano Fan coil
- (9) Wi-fi module
- (10) Diverting/mixing valve (code sold in kit B - Hybrid MS)
- (11) Photovoltaic input board (code sold in kit B - Hybrid MS)
- (12) Photovoltaic string with inverter
- (13) External probe

### Possible solutions\*:

- 1 HT zone or 1 direct LT zone
- 2 HT zones or 2 direct LT zones
- 1 HT zone + 1 LT zone (as per diagram)
- Cooling using TIVANO FAN COIL



(\*) The mixed zone is managed with motorised mixing valves and self-modulating circulating pumps

(1) For more info about combining boilers and heat pumps, refer to the tables in the "GUIDE TO SYSTEM CONFIGURATION" page 68.

(2) The hybrid system management control T300 code 20205322 is necessary to create a wall-mounted hybrid system with the Mynute EVO X and EXCLUSIVE EVO X boilers.

Only for boilers with REC10MHC device already installed on the boiler. If it is installed on the wall, the control on the boiler must be disconnected and remotely controlled using a specific accessory. For all configurations, refer to the applicable design and installation standards and to the product's technical manuals.

**KIT C COMPOSITION (HYBRID WITHOUT HEATER) - FOR DHW MANAGEMENT WITH COMBINED BOILER**

CODE	DESCRIPTION	MANAGEMENT COMFORT	MANAGEMENT DHW	MANAGEMENT ZONES
20134963	HYBRID 1 DIR COMBI - WITHOUT HEATER	hot / cold	-  -	1 DIRECT
<b>CONSISTING OF:</b>				
20130801	CONNECT HYBRID 1D MODULE			1 pc.
1220559	OUTDOOR TEMPERATURE PROBE KIT WITH CONNECTOR			1 pc.
20134964	HYBRID 2 DIR COMBI - WITHOUT HEATER	hot / cold	-  -	2 DIRECT
<b>CONSISTING OF:</b>				
20130802	CONNECT HYBRID 2D MODULE			1 pc.
1220559	OUTDOOR TEMPERATURE PROBE KIT WITH CONNECTOR			1 pc.
20134965	HYBRID 1HT/1LT COMBI - WITHOUT HEATER	hot / cold	-  -	1HT + 1LT
<b>CONSISTING OF:</b>				
20130803	CONNECT HYBRID HT/LT MODULE			1 pc.
1220559	OUTDOOR TEMPERATURE PROBE KIT WITH CONNECTOR			1 pc.

 Combined condensing boiler.

To house the Hybrid kits it is necessary to purchase the BOX for built-in installation, code 20130808 and, if necessary, the cock kit code 20131752.

The Hybrid system codes do not include the boiler, the hybrid system command panel, the heat pump, storage cylinder or inertial storage tank: these must be chosen from the codes indicated in the combination tables.

For input of signal from the photovoltaic system, it is necessary to use the optional kit code 20165741.

(\*) Refer to the "Command panels for hybrid systems" table for the system command panel.

## HYBRID SYSTEMS FOR HYBRID READY COMBINED BOILER

### HYBRID SYSTEMS WITHOUT HEATER: WITH KIT C, COMBINED BOILER, HEAT PUMP - TWO ZONES (1HT + 1LT)

The system is controlled by the REC10MHC hybrid control connected to Connect Hybrid, and the outdoor temperature probe connected to the boiler.

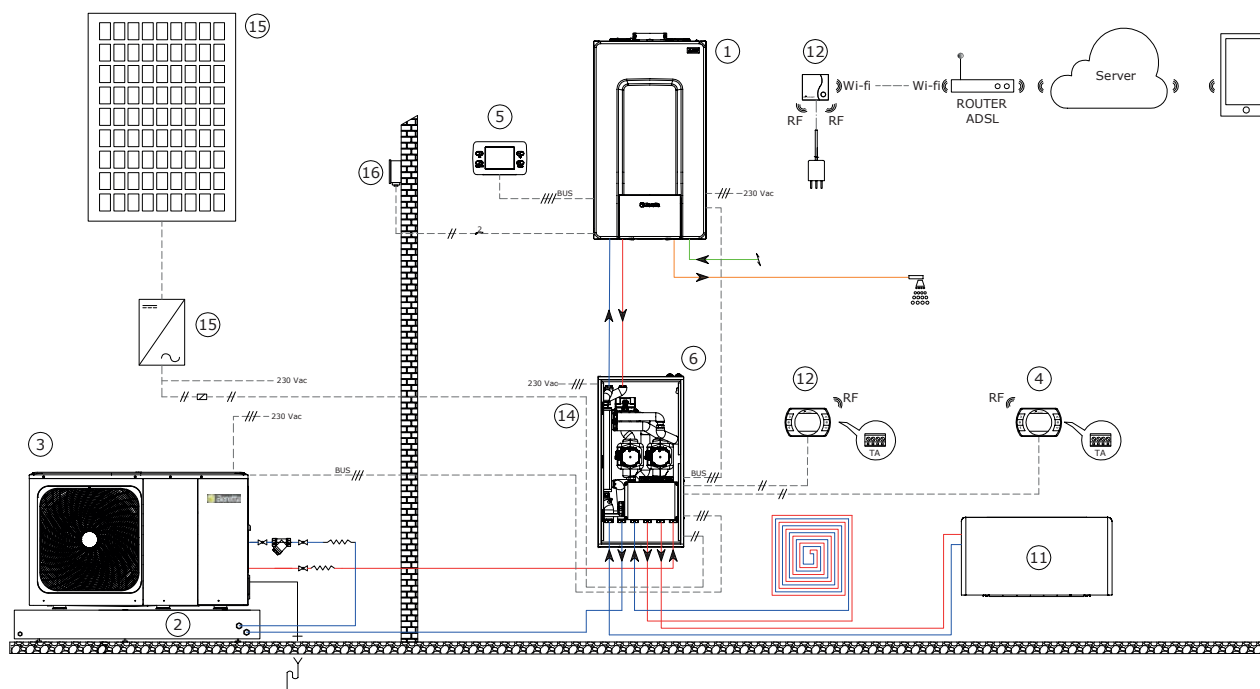

Basic layout purely for illustrative purposes

#### KEY:

- (1) Wall hung boiler <sup>(1)</sup>
- (2) STOR H 50 - 50-litre inertial buffer tank
- (3) Heat pump <sup>(1)</sup>
- (4) Hi, Comfort T100 Control
- (5) REC10MHC hybrid systems management control <sup>(2)</sup>
- (6) Kit C - Hybrid WITHOUT HEATER, built into the BOX and with cock kit (optional)
- (7) Tivano Fan coil
- (8) Wi-fi module
- (9) Optional photovoltaic input board (code 20165741)
- (10) Photovoltaic string with inverter
- (11) External probe

#### Possible solutions\*:

- 1 HT zone or 1 direct LT zone
- 2 HT zones or 2 direct LT zones
- 1 HT zone + 1 LT zone (as per diagram)
- Cooling using TIVANO FAN COIL

(\*) The mixed zone is managed with motorised mixing valves and self-modulating circulating pumps

(1) For more info about combining boilers and heat pumps, refer to the tables in the "GUIDE TO SYSTEM CONFIGURATION" page 68.

(2) The hybrid system management control T300 code 20205322 is necessary to create a wall-mounted hybrid system with the Mynute EVO X and EXCLUSIVE EVO X boilers.

Only for boilers with REC10MHC device already installed on the boiler. If it is installed on the wall, the control on the boiler must be disconnected and remotely controlled using a specific accessory. For all configurations, refer to the applicable design and installation standards and to the product's technical manuals.



- The HYBRID Systems consisting of heating-only boiler, solar collectors and Beretta heat pump form a class A+ system
- Modular thermally autonomous hybrid system
- Suitable for heating, cooling and domestic water
- Management of HEATING-ONLY condensing boiler, heat pump and solar thermal unit
- REC10MHC, Hybrid System Management Control, to be installed in the home on the wall or on the boiler
- Two possible configurations (D, E) each with 3 kits to manage a different number of zones (1 DIR; 2 DIR; 1HT+1LT):  
KIT D - (HYBRID DS) - for Heat Pump and heating-only boiler with solar connectable to a double-coil heater  
KIT E - (HYBRID DS) - for heating-only boiler and Heat Pump connectable to a double-coil heater
- New under-boiler distribution module (kit) for applications without hydraulic separator



**HYBRID SYSTEMS FOR HEATING-ONLY BOILERS**

CODE	DESCRIPTION	MANAGEMENT COMFORT <sup>(1)</sup>	MANAGEMENT DHW	MANAGEMENT ZONES
<b>UNDER-BOILER KIT - DISTRIBUTION MODULE WITHOUT SEPARATOR FOR CONNECTION DS HEATER WITH HEATING-ONLY BOILER, SOLAR AND HEAT PUMP</b>				
20185398	HYBRID UNDER-BOILER SYSTEM 1.DIR + DHW <sup>(A)</sup>	hot / cold		1 DIRECT
<b>KIT D (HYBRID DS) - FOR MANAGEMENT OF DS HEATER WITH HEATING-ONLY BOILER AND SOLAR</b>				
20134966	HYBRID DS 1 DIR - DHW (HEATING ONLY-SOLAR)	hot / cold	-	1 DIRECT
20134967	HYBRID DS 2 DIR - DHW (HEATING ONLY-SOLAR)	hot / cold	-	2 DIRECT
20134968	HYBRID DS 1HT/1LT - DHW (HEATING ONLY-SOLAR)	hot / cold	-	1HT + 1LT
<b>KIT E (HYBRID DS) - FOR MANAGEMENT OF DS HEATER WITH HEATING-ONLY BOILER AND HEAT PUMP</b>				
20134969	HYBRID DS 1 DIR - DHW (HEATING ONLY-HEAT PUMP)	hot / cold	-	1 DIRECT
20134970	HYBRID DS 2 DIR - DHW (HEATING ONLY-HEAT PUMP)	hot / cold	-	2 DIRECT
20134971	HYBRID DS 1HT/1LT - DHW (HEATING ONLY-HEAT PUMP)	hot / cold	-	1HT + 1LT

Solar thermal unit; Hydronic Unit heat pump; Hybrid Ready combined condensing boiler.

To house the Hybrid kits it is necessary to purchase the BOX, also compatible for built-in installation, code 20130808 and, if necessary, the cock kit code 20131752.

The Hybrid kit codes do not include boiler, solar collector, heat pump, heater and inertial buffer tank: to be chosen from the codes specified in the combination tables.

(A) Code consisting of 1 hydraulic module for direct 1-zone hybrid distribution (code 20165227), 1 outdoor temperature sensor kit with connector (code 1220559). For hybrid system management command (not included in the kit), refer to the "Management commands for hybrid systems" table.

Compatible with Heat Pump only up to model 012/012T. Check the presence of the bypass valve (cod. 20182807) and add it if necessary.

(1) Comfort management with boiler and heat pump.

## HYBRID SYSTEMS FOR HYBRID READY HEATING-ONLY BOILER

### MANAGEMENT COMMANDS FOR HYBRID SYSTEMS

CODE	MODEL
20207834	REC10MHC hybrid system management command <sup>(1)</sup>
20205322	T300 Hi, Comfort Management control

(1) The REC10MHC panel is used to manage the operation of the HYDRO UNIT M heat pump in a hybrid system.

(2) The T300 panel is used to manage the operation of the EXCLUSIVE EVO X and MYNUTE EVO X boilers in a hybrid system.

### BOX FOR HYBRID KIT

CODE	MODEL	DIMENSIONS H x W x D (mm)
20130808	Box (also for built-in installation) for CONNECT HYBRID <sup>(2)</sup>	797 x 400 x 160
20131752	Cock kit for CONNECT HYBRID	-

(1) Paintable box.

### HEATING-ONLY CONDENSING BOILERS (COMPATIBLE WITH UNDER-BOILER KIT AND KITS D AND E)

CODICE MTN <sup>(1)</sup>	MODEL	GAS	DIMENSIONS H x W x D (mm)	HEAT INPUT OF HEAT. / DOMESTIC WATER Min - Max (kW)	domestic water production (l/min-Δt 25°C)	ENERGY EFFICIENCY CLASS	
						(D→A+++)*	(F→A+)*
<b>HEATING ONLY</b>							
20206144	EXCLUSIVE EVO X 25R	MTN/GPL <sup>(1)</sup>	740 x 420 x 275	1,9 - 20,0 / 1,9 - 25,0	-	A	-
20206145	EXCLUSIVE EVO X 35R	MTN/GPL <sup>(1)</sup>	740 x 420 x 275	2,7 - 32,0 / 2,7 - 34,9	-	A	-
20205315	MYNUTE EVO X 20 R	MTN/GPL <sup>(1)</sup>	740 x 420 x 275	2,5 - 20,0 / 2,5 - 20,0	-	A	-
20205316	MYNUTE EVO X 30 R	MTN/GPL <sup>(1)</sup>	740 x 420 x 275	3,5 - 30,0 / 3,5 - 34,9	-	A	-
20187766	CIAO X 15 R	MTN	740 x 420 x 275	3,1-15,0 / 3,1-25,0	-	A	-
20187767	CIAO X 25R	MTN	740 x 420 x 275	3,1-20,0 / 3,1-25,0	-	A	-

(\*) HEATING: the energy efficiency class of the products ranges from D up to A+++ / DHW: the energy efficiency class of the products ranges from F up to A+

(1) In this models boilers gas switch-over, thanks to the new ACC combustion system, is carried out through electronic settings.

**HEAT PUMPS (COMPATIBLE WITH UNDER-BOILER KITS AND KITS D AND E)**

CODE	MODEL	DIMENSIONS H x W x D (mm)	HEAT. <sup>(1)</sup> /COOL. <sup>(2)</sup> OUTPUT (kW)	ENERGY EFFICIENCY CLASS	
				(D → A+++)*	
				55°C	35°C

**SINGLE-PHASE HEAT PUMPS**

20203411	HYDRO UNIT M 004	718 x 1295 x 426	4,20 / 4,50	A++	A+++
20203413	HYDRO UNIT M 006	718 x 1295 x 426	6,35 / 6,50	A++	A+++
20203414	HYDRO UNIT M 008	865 x 1385 x 523	8,40 / 8,30	A++	A+++
20203416	HYDRO UNIT M 010	865 x 1385 x 523	10,00 / 9,90	A++	A+++
20203656	HYDRO UNIT M 012	865 x 1385 x 523	12,10 / 12,00	A++	A+++
20203659	HYDRO UNIT M 014	865 x 1385 x 523	14,50 / 13,50	A++	A+++

**THREE-PHASE HEAT PUMPS**

20203672	HYDRO UNIT M 012T	865 x 1385 x 523	12,10 / 12,00	A++	A+++
20203674	HYDRO UNIT M 014T	865 x 1385 x 523	14,50 / 13,50	A++	A+++

(\*) HEATING: the range of energy efficiency class of this products category is between D and A+++

(1) Outdoor air d.b. + 7 °C / w.b. + 6 °C, water 30°C - 35°C.

(2) Outdoor air d.b. + 35 °C/w.b. + 24°C, water 23°C - 18°C.

Models that can be used for stand-alone full electric installation with commands supplied as standard, and for hybrid systems in combination with the REC10MHC command (refer to the specific section).

**SOLAR COLLECTORS (FOR KIT A ONLY)**

CODE	DESCRIPTION	MODEL
20201328	Sealed solar collector - 2,5 m <sup>2</sup>	SCF-25/4B A
20201335	Sealed solar collector - 2 m <sup>2</sup>	SCF-20/4B A

For bracket codes and glycol refer to the solar thermal section.

**DOUBLE-COIL BOILERS (COMPATIBLE WITH UNDER-BOILER KITS AND KITS D AND E)**

CODE	MODEL	DIMENSIONS H x Ø (mm)	HEATER CAPACITY (litres)	DISPERSION (W)	ENERGY EFFICIENCY CLASS

**DOUBLE-COIL HEATERS**

20117881	IDRA DS 200	1338 x 604	208 double coil	62	B
20117882	IDRA DS 300	1838 x 604	301 double coil	69	B

## HYBRID SYSTEMS FOR HYBRID READY HEATING-ONLY BOILER

### SINGLE-COIL HEATERS (COMPATIBLE WITH KIT E)

CODE	MODEL	DIMENSIONS H x Ø (mm)	HEATER CAPACITY (litres)	DISPERSION (W)	ENERGY EFFICIENCY CLASS
					
<b>SINGLE-COIL HEATERS FOR HEAT PUMP</b>					
20117745	IDRA HP 300 <sup>(1)</sup>	1615 x 600	263 single-coil	85	C
20204198	IDRA C-HP 150 MS	1138 x 604	170 single-coil	55	B
20204200	IDRA C-HP 200 MS	1354 x 604	210 single-coil	58	B
20204202	IDRA C-HP 300 MS	1838 x 604	305 single-coil	68	B

(1) Heaters for Hybrid MS Systems.

### ACCESSORIES FOR IDRA HP 300 SINGLE-COIL STORAGE TANKS (COMPATIBLE WITH KIT E)

CODE	DESCRIPTION
4383504	Solar heat exchanger 0,8 m <sup>2</sup> for IDRA HP 300 <sup>(1)</sup>
20203248	Solar heat exchanger 0,8 m <sup>2</sup> for C-HP 150-300
4383270	Single-phase resistance kit 1,5 kW 1 "1/2

(1) The accessory must be ordered together with the base unit (if the latter is not available, the accessory cannot be ordered). It is supplied uninstalled.

### INERTIAL BUFFER TANKS (COMPATIBLE WITH UNDER-BOILER KIT AND KITS D AND E)

CODE	DESCRIPTION
20104496	25-litre cylindrical technical tank kit <sup>(1)</sup>
20171999	STOR H 50 - 50-litre inertial buffer tank <sup>(1)</sup>
20142300	STOR H 100 - 100-litre technical hot/cold tank kit <sup>(1) (2)</sup>

(1) Provide at least 3,5 litres per kW of heat pump cooling output.

(2) Code with limited availability.

**ACCESSORIES FOR HYBRID SYSTEMS (COMPATIBLE WITH KIT D)**

CODE	DESCRIPTION
20165741	Photovoltaic input board kit <sup>(1)</sup>

(1) To be used only if there is no diverting valve kit code 20131755 within the packages.

**KIT D (HYBRID DS) COMPOSITION - FOR MANAGEMENT (\*) OF DS HEATER WITH HEATING-ONLY BOILER AND SOLAR**

CODE	DESCRIPTION	MANAGEMENT COMFORT	MANAGEMENT DHW	MANAGEMENT ZONES
20134966	HYBRID DS 1 DIR - DHW (HEATING ONLY-SOLAR)	hot / cold	-	1 DIRECT
<b>CONSISTING OF:</b>				
20130801	CONNECT HYBRID 1D MODULE			1 pc.
1220559	OUTDOOR TEMPERATURE PROBE KIT WITH CONNECTOR			1 pc.
20116162	CONNECT SOLAR R RETURN-ONLY HYDRAULIC UNIT - 7,5m			1 pc.
20168672	SOLAR THERMAL UNIT INTERFACE KIT			1 pc.
1220599	POCKET PROBE KIT			1 pc.
1150529	3/4" MIXING VALVE			1 pc.
20134967	HYBRID DS 2 DIR - DHW (HEATING ONLY-SOLAR)	hot / cold	-	2 DIRECT
<b>CONSISTING OF:</b>				
20130802	CONNECT HYBRID 2D MODULE			1 pc.
1220559	OUTDOOR TEMPERATURE PROBE KIT WITH CONNECTOR			1 pc.
20116162	CONNECT SOLAR R RETURN-ONLY HYDRAULIC UNIT - 7,5m			1 pc.
20168672	SOLAR THERMAL UNIT INTERFACE KIT			1 pc.
1220599	POCKET PROBE KIT			1 pc.
1150529	3/4" MIXING VALVE			1 pc.
20134968	HYBRID DS 1HT/1LT - DHW (HEATING ONLY-SOLAR)	hot / cold	-	1HT + 1LT
<b>CONSISTING OF:</b>				
20130803	CONNECT HYBRID HT/LT MODULE			1 pc.
1220559	OUTDOOR TEMPERATURE PROBE KIT WITH CONNECTOR			1 pc.
20116162	CONNECT SOLAR R RETURN-ONLY HYDRAULIC UNIT - 7,5m			1 pc.
20168672	SOLAR THERMAL UNIT INTERFACE KIT			1 pc.
1220599	POCKET PROBE KIT			1 pc.
1150529	3/4" MIXING VALVE			1 pc.

Solar thermal unit; Built-in combined condensing boiler

To house the Hybrid kits it is necessary to purchase the BOX for built-in installation, code 20130808 and, if necessary, the cock kit code 20131752.

The Hybrid system codes do not include the boiler, the hybrid system command panel, solar collector, heat pump, storage cylinder or inertial storage tank: these must be chosen from the codes indicated in the combination tables.

(\*) Refer to the "Command panels for hybrid systems" table for the system command panel.

## HYBRID DS SYSTEMS: WITH KIT D, HEATING-ONLY BOILER, HEAT PUMP, SOLAR - TWO ZONES (1HT + 1LT)

The system is controlled by the REC10MHC hybrid control connected to Connect Hybrid, and the outdoor temperature probe connected to the boiler.

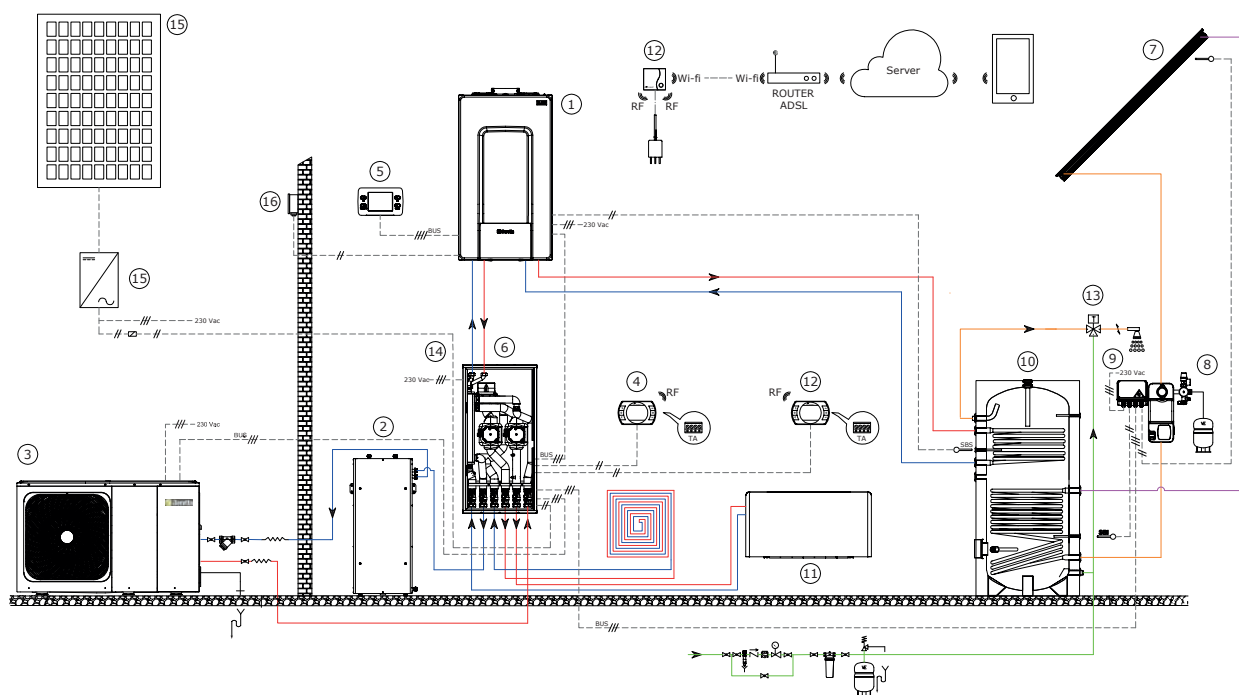

Basic layout purely for illustrative purposes

### KEY:

- (1) Wall hung boiler <sup>(1)</sup>
- (2) STOR H 50 - 50-litre inertial buffer tank
- (3) Heat pump <sup>(1)</sup>
- (4) Hi, Comfort T100 Control
- (5) REC10MHC or T300 hybrid systems management control <sup>(2)</sup>
- (6) Kit D - Hybrid DS (heating only - solar) built into the BOX and with optional cock kit
- (7) Solar collector
- (8) Return-only solar hydraulic unit (code sold in kit D - Hybrid DS - heating-only / solar)
- (9) Solar management board (code sold in kit D - Hybrid DS - heating-only / solar)
- (10) Double-coil domestic water heater
- (11) Tivano Fan coil
- (12) Wi-fi module
- (13) Thermostatic mixing valve (code sold in kit D - Hybrid DS - heating-only / solar)
- (14) Photovoltaic input board (code sold in kit D - Hybrid DS)
- (15) Photovoltaic string with inverter
- (16) External probe

### Possible solutions\*:

- 1 HT zone or 1 direct LT zone
- 2 HT zones or 2 direct LT zones
- 1 HT zone + 1 LT zone (as per diagram)
- Cooling using TIVANO FAN COIL

(\*) The mixed zone is managed with motorised mixing valves and self-modulating circulating pumps

(1) For more info about combining boilers and heat pumps, refer to the tables in the "GUIDE TO SYSTEM CONFIGURATION" page 68.

(2) The hybrid system management control T300 code 20205322 is necessary to create a wall-mounted hybrid system with the Mynute EVO X and EXCLUSIVE EVO X boilers. Only for boilers with REC10MHC device already installed on the boiler. If it is installed on the wall, the control on the boiler must be disconnected and remotely controlled using a specific accessory. For all configurations, refer to the applicable design and installation standards and to the product's technical manuals

**KIT E (HYBRID DS) COMPOSITION - FOR MANAGEMENT OF DS HEATER WITH HEATING-ONLY BOILER AND HEAT PUMP**

CODE	DESCRIPTION	MANAGEMENT COMFORT	MANAGEMENT DHW	MANAGEMENT ZONES
20134969	HYBRID DS 1 DIR - DHW (HEATING ONLY-HEAT PUMP)	hot / cold	-	1 DIRECT
<b>CONSISTING OF:</b>				
20130801	CONNECT HYBRID 1D MODULE			1 pc.
1220559	OUTDOOR TEMPERATURE PROBE KIT WITH CONNECTOR			1 pc.
20131755	DIVERTING VALVE KIT FOR HEATER MANAGEMENT (WITH PHOTOVOLTAIC INPUT)			1 pc.
1220599	POCKET PROBE KIT			1 pc.
20134970	HYBRID DS 2 DIR - DHW (HEATING ONLY-HEAT PUMP)	hot / cold	-	2 DIRECT
<b>CONSISTING OF:</b>				
20130802	CONNECT HYBRID 2D MODULE			1 pc.
1220559	OUTDOOR TEMPERATURE PROBE KIT WITH CONNECTOR			1 pc.
20131755	DIVERTING VALVE KIT FOR HEATER MANAGEMENT (WITH PHOTOVOLTAIC INPUT)			1 pc.
1220599	POCKET PROBE KIT			1 pc.
20134971	HYBRID DS 1HT/1LT - DHW (HEATING ONLY-HEAT PUMP)	hot / cold		1HT + 1LT
<b>CONSISTING OF:</b>				
20130803	CONNECT HYBRID HT/LT MODULE			1 pc.
1220559	OUTDOOR TEMPERATURE PROBE KIT WITH CONNECTOR			1 pc.
20131755	DIVERTING VALVE KIT FOR HEATER MANAGEMENT (WITH PHOTOVOLTAIC INPUT)			1 pc.
1220599	POCKET PROBE KIT			1 pc.

Heat pump; Hybrid Ready condensing combi boiler.

To house the Hybrid kits it is necessary to purchase the BOX for built-in installation, code 20130808 and, if necessary, the cock kit code 20131752.

The Hybrid system codes do not include the boiler, the hybrid system command panel, the heat pump, storage cylinder or inertial storage tank: these must be chosen from the codes indicated in the combination tables.

(\*) Refer to the "Command panels for hybrid systems" table for the system command panel.

## HYBRID DS SYSTEMS: WITH KIT E, HEATING-ONLY BOILER, HEAT PUMP - TWO ZONES (1HT + 1LT)

The system is controlled by the REC10MHC hybrid control connected to Connect Hybrid, and the outdoor temperature probe connected to the boiler.

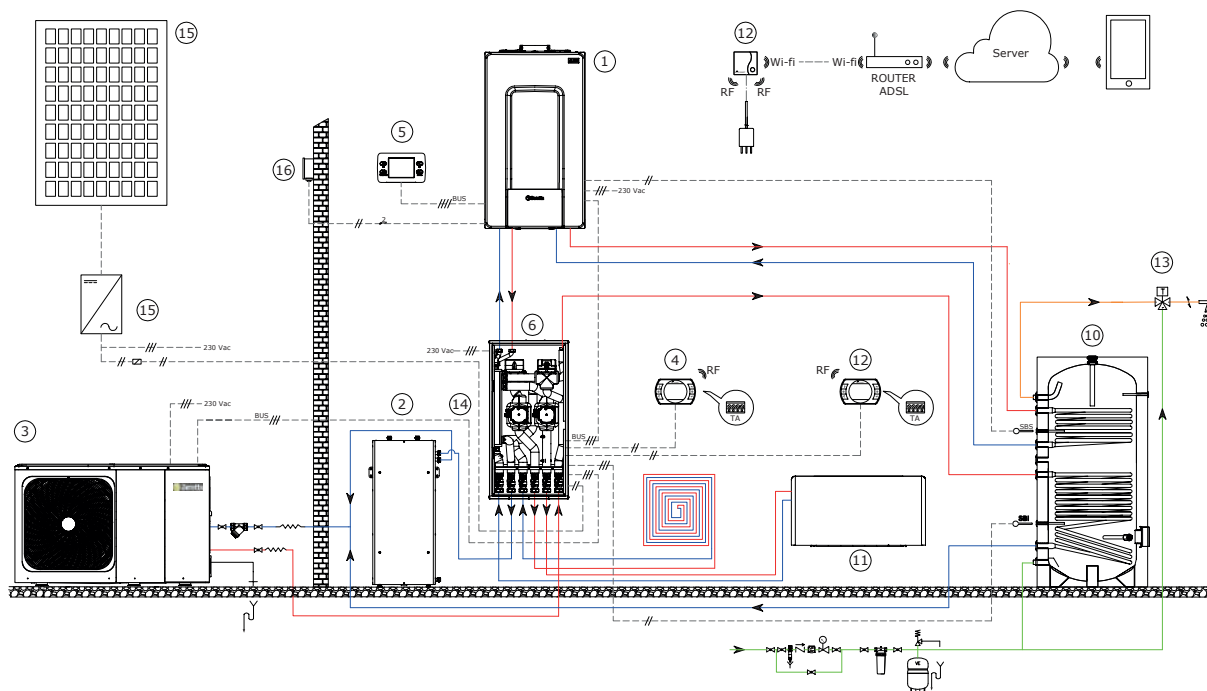

Basic layout purely for illustrative purposes

### KEY:

- (1) Wall hung boiler <sup>(1)</sup>
- (2) STOR H 50 - 50-litre inertial buffer tank
- (3) Heat pump <sup>(1)</sup>
- (4) Hi, Comfort T100 Control
- (5) REC10MHC or T300 hybrid systems management control (code sold in kit E - Hybrid DS - heating-only / PD) <sup>(2)</sup>
- (6) Kit E - Hybrid DS (heating only - Heat Pump) built into the BOX and with optional cock kit
- (7) Double-coil domestic water heater
- (8) Tivano Fan coil
- (9) Wi-fi module
- (10) Thermostatic mixing valve (optional code)
- (11) Photovoltaic input board (included in kit E - Hybrid DS - heating-only / Heat Pump)
- (12) Photovoltaic string with inverter
- (13) External probe

### Possible solutions\*:

- 1 HT zone or 1 direct LT zone
- 2 HT zones or 2 direct LT zones
- 1 HT zone + 1 LT zone (as per diagram)
- Cooling using TIVANO FAN COIL

(\* ) The mixed zone is managed with motorised mixing valves and self-modulating circulating pumps

(1) For more info about combining boilers and heat pumps, refer to the tables in the "GUIDE TO SYSTEM CONFIGURATION" page 68.

(2) The hybrid system management control T300 code 20205322 is necessary to create a wall-mounted hybrid system with the Mynute EVO X and EXCLUSIVE EVO X boilers. Only for boilers with REC10MHC device already installed on the boiler. If it is installed on the wall, the control on the boiler must be disconnected and remotely controlled using a specific accessory. For all configurations, refer to the applicable design and installation standards and to the product's technical manuals



- The system consists of 2 main components: condensing boiler POWER EVO-X or POWER MAX, and heat pump HYDRO UNIT M 004÷016 or HYDRO UNIT M 018÷030
- Multi-energy hybrid system suitable for central heating and domestic hot water production
- Possibility of solar thermal integration
- Wide range of accessories



## HEATING-ONLY CONDENSING BOILERS

CODE	MODEL	DIMENSIONS H x W x D (mm)	HEAT INPUT HEATING MODE Min - Max (kW)	ENERGY EFFICIENCY CLASS
<b>SINGLE-PHASE HEAT PUMPS</b>				
20190069	POWER EVO-X 50 DEP	740 x 470 x 350	5,20-34,9	A
20190070	POWER EVO-X 50	740 x 470 x 350	5,20-45	A
20190072	POWER EVO-X 65	740 x 470 x 453	8,20-55	A
20190073	POWER EVO-X 80	740 x 470 x 453	8,20-70	A
20128431	POWER MAX 65 P	1000 x 600 x 435	57-13,6	A
20128432	POWER MAX 80 P	1000 x 600 x 435	68-13,6	A
20128433	POWER MAX 100	1000 x 600 x 435	90-19,4	A
20128434	POWER MAX 110	1000 x 600 x 435	97-19,4	A
20128435	POWER MAX 130 (115 Hi)	1170 x 600 x 435	112-22,4	A
20128436	POWER MAX 150	1170 x 600 x 435	131-26,2	A

(\*) In combination with optional control kit Hi, Comfort T100 code 20193352 (class V) or optional control kit Hi, Comfort T100 Wi-F code 20193354 (class VI) connected to the boiler or, when present, to the additional zone card kit code 20220356.

## Heat Pump

# MONOBLOC WALL-HUNG HYBRID SYSTEM "MAX"

### MONOBLOC HEAT PUMP

CODE	MODEL	DIMENSIONS H x W x D (mm)	HEAT. <sup>(1)</sup> /COOL. <sup>(2)</sup> OUTPUT (kW)	ENERGY EFFICIENCY CLASS	
				(D → A+++)*	
<b>SINGLE-PHASE HEAT PUMPS</b>					
20203416	HYDRO UNIT M 010	865 x 1385 x 523	10.00 / 9.90	A <sup>++</sup>	A <sup>+++</sup>
20203656	HYDRO UNIT M 012	865 x 1385 x 523	12.10 / 12.00	A <sup>++</sup>	A <sup>+++</sup>
20203659	HYDRO UNIT M 014	865 x 1385 x 523	14.50 / 13.50	A <sup>++</sup>	A <sup>+++</sup>
20203660	HYDRO UNIT M 016	865 x 1385 x 523	15.90 / 14.20	A <sup>++</sup>	A <sup>+++</sup>
<b>THREE-PHASE HEAT PUMPS</b>					
20203672	HYDRO UNIT M 012T	865 x 1385 x 523	12.10 / 12.00	A <sup>++</sup>	A <sup>+++</sup>
20203674	HYDRO UNIT M 014T	865 x 1385 x 523	14.50 / 13.50	A <sup>++</sup>	A <sup>+++</sup>
20203678	HYDRO UNIT M 016T	865 x 1385 x 523	15.90 / 14.20	A <sup>++</sup>	A <sup>+++</sup>
20194173	HYDRO UNIT M 018T	1558 x 1129 x 528	18,00/ 18,50	A <sup>++</sup>	A <sup>+++</sup>
20194174	HYDRO UNIT M 022T	1558 x 1129 x 528	22,00/ 23,00	A <sup>++</sup>	A <sup>+++</sup>
20194175	HYDRO UNIT M 026T	1558 x 1129 x 528	26,00/ 27,00	A <sup>+</sup>	A <sup>+++</sup>
20194176	HYDRO UNIT M 030T	1558 x 1129 x 528	30,10/ 31,00	A <sup>+</sup>	A <sup>+++</sup>

(\*) HEATING: the range of energy efficiency class of this products category is between D and A+++

(1) External air temperature DBT + 7 °C / WBT + 6 °C, Water Temperature 30 °C - 35 °C;

(2) External air temperature DBT + 35 °C/ WBT + 24 °C, Water Temperature 23 °C - 18 °C.

DBT = Dry Bulb Temperature - WBT = Wet Bulb Temperature

### INERTIAL BUFFER TANKS

CODE	MODEL	DIMENSIONS H x W x D (mm)	CAPACITY (l)	DISPERSION (W)	ENERGY EFFICIENCY CLASS
<b>SINGLE-PHASE HEAT PUMPS</b>					
20056180	STOR H 200	1395 x 550	203	68	C
20056181	STOR H 300	1560 x 600	277	82	C
20056183	STOR H 500	1840 x 700	473	114	C

### COMPATIBLE SOLAR HYDRAULIC UNITS

CODE	MODEL
20116161	Flow and return hydraulic group - CONNECT SOLAR M/R - 7.5 m <sup>2</sup>

**COMPATIBLE SOLAR COLLECTORS**

CODE	MODEL	DIMENSIONS H x W x D (mm)	TOTAL AREA (m <sup>2</sup> )
20201328	Sealed solar collector - 2,5 m <sup>2</sup>	2020 x 1235 x 85	2,49
20201335	Sealed solar collector - 2 m <sup>2</sup>	1625 x 1235 x 85	2

**COMPATIBLE CYLINDER FOR DHW**

CODE	MODEL	DIMENSIONS H x W x D (mm)	CAPACITY (l)	DISPERSION (W)	ENERGY EFFICIENCY CLASS
20117745	IDRA HP 300	1615 x 600	263 single-coil	85	C
20117746	IDRA HP 500	1690 x 750	470 single-coil	112	C
20204202	IDRA C-HP 300 MS	1838 x 604	305 single-coil	68	B
20204204	IDRA C-HP 500 MS	1793 x 755	500 single-coil	84	B
20204206	IDRA C-HP 800 MS	1835 x 974	735 single-coil	94	-
20204208	IDRA C-HP 1000 MS	2155 x 974	890 single-coil	101	-
20117883	IDRA DS 430	1644 x 755	430 double-coil	75	B
20117884	IDRA DS 550	1988 x 755	551 double-coil	85	-
20132278	IDRA DS 750	1846 x 1000	731 double-coil	94	-
20132281	IDRA DS 1000	2171 x 1000	883 double-coil	101	-
20136241	IDRA N DS 1500	2185 x 1200	1390 double-coil	162	-
20136242	IDRA N DS 2000	2470 x 1300	1950 double-coil	186	-

## GUIDE TO SYSTEM CONFIGURATION



- 1. SELECTION OF WALL-HUNG BOILER RANGE**
  - 1.1 POWER EVO-X boiler-Heat pump combinations
  - 1.2 POWER MAX boiler-Heat pump combinations
- 2. WALL-HUNG BOILER ACCESSORIES**
  - 2.1 Accessories for POWER EVO-X boilers
  - 2.2 Accessories for POWER MAX boilers
- 3. ACCESSORIES TO COMPLETE THE SYSTEM**
  - 3.1 Hydraulic accessories
  - 3.2 Domestic hot water tank accessories
- 4. HI, COMFORT CONTROLS**

### 1. SELECTION OF WALL-HUNG BOILER RANGE

Boiler output power (80°/60°) [kW]		Stand alone		Number of cascading boilers		
Boiler Range	Boiler Description	1	2	3	4	5
POWER EVO-X	POWER EVO-X 50	34	68			
	POWER EVO-X 50 DEP	44	88			
	POWER EVO-X 65	54	107			
	POWER EVO-X 80	68	136			
POWER MAX	POWER MAX 100	56	111			
	POWER MAX 110	67	134			
	POWER MAX 130	88	177	265	353	
	POWER MAX 150	95	191	286	381	
	POWER MAX 65 P	110	220	329	439	549
	POWER MAX 80 P	129	258	387	516	645

**1.1 POWER EVO-X BOILER-HEAT PUMP COMBINATIONS (RECOMMENDED)\***

Combinations with stand-alone boilers													
CODE	MODEL	Nominal power (kW)	1x HYDRO UNIT M 010 (20203416)	1x HYDRO UNIT M 012 (20203656)	1x HYDRO UNIT M 014 (20203659)	1x HYDRO UNIT M 016 (20203660)	1x HYDRO UNIT M 012T (20203672)	1x HYDRO UNIT M 014T (20203674)	1x HYDRO UNIT M 016T (20203678)	1x HYDRO UNIT M 018T (20194173)	1x HYDRO UNIT M 022T (20194174)	1x HYDRO UNIT M 026T (20194175)	1x HYDRO UNIT M 030T (20194176)
			10	12,1	14,5	15,9	12,1	14,5	15,9	18	22	26	30,1
20190069	POWER EVO-X 50 DEP	34	•	•	•	•	•	•	•				
20190070	POWER EVO-X 50	43,9		•	•	•	•	•	•	•			
20190072	POWER EVO-X 65	53,6			•	•		•	•	•	•	•	
20190073	POWER EVO-X 80	68,2								•	•	•	•

(\*) The following combinations guarantee the best energy performance; for the full list of certified hybrid systems please refer to the company declaration.

Combinations with cascading boilers												
CODE	MODEL	Nominal power (kW)	1x HYDRO UNIT M 018T (20194173)	1x HYDRO UNIT M 022T (20194174)	1x HYDRO UNIT M 026T (20194175)	1x HYDRO UNIT M 030T (20194176)	2x HYDRO UNIT M 018T (20194173)	2x HYDRO UNIT M 022T (20194174)	2x HYDRO UNIT M 026T (20194175)	2x HYDRO UNIT M 030T (20194176)	3x HYDRO UNIT M 018T (20194173)	3x HYDRO UNIT M 022T (20194174)
			18	22	26	30,1	36	44	52	60,2	54	66
20190069	2x POWER EVO-X 50 DEP	68	•	•	•	•						
20190070	2x POWER EVO-X 50	87,8		•	•	•	•					
20190072	2x POWER EVO-X 65	107,2				•	•	•	•			
20190073	2x POWER EVO-X 80	136,4					•	•	•	•	•	•

(\*) The following combinations guarantee the best energy performance; for the full list of certified hybrid systems please refer to the company declaration.

# MONOBLOC WALL-HUNG HYBRID SYSTEM "MAX"

## 1.2 POWER MAX BOILER-HEAT PUMP COMBINATIONS (RECOMMENDED)\*

Combinations with stand-alone boilers															
CODE	MODEL	Nominal power (kW)	1x HYDRO UNIT M 014 (20203659)	1x HYDRO UNIT M 016 (20203660)	1x HYDRO UNIT M 014T (20203674)	1x HYDRO UNIT M 016T (20203678)	1x HYDRO UNIT M 018T (20194173)	1x HYDRO UNIT M 022T (20194174)	1x HYDRO UNIT M 026T (20194175)	1x HYDRO UNIT M 030T (20194176)	2x HYDRO UNIT M 018T (20194173)	2x HYDRO UNIT M 022T (20194174)	2x HYDRO UNIT M 026T (20194175)	2x HYDRO UNIT M 030T (20194176)	3x HYDRO UNIT M 018T (20194173)
			14,5	15,9	14,5	15,9	18	22	26	30,1	36	44	52	60,2	54
20128431	POWER MAX 65 P	55,7	•	•	•	•	•	•	•						
20128432	POWER MAX 80 P	67					•	•	•	•					
20128433	POWER MAX 100	88,3							•	•	•	•			
20128434	POWER MAX 110	95,3							•	•	•	•			
20128435	POWER MAX 130	109,8								•	•	•	•		•
20128436	POWER MAX 150	129									•	•	•	•	•

(\*) The following combinations guarantee the best energy performance; for the full list of certified hybrid systems please refer to the company declaration.

Combinations with cascading boilers															
CODE	MODEL	Nominal power (kW)	1x HYDRO UNIT M 030T (20194176)	2x HYDRO UNIT M 018T (20194173)	2x HYDRO UNIT M 022T (20194174)	2x HYDRO UNIT M 026T (20194175)	2x HYDRO UNIT M 030T (20194176)	3x HYDRO UNIT M 018T (20194173)	3x HYDRO UNIT M 022T (20194174)	3x HYDRO UNIT M 026T (20194175)	3x HYDRO UNIT M 030T (20194176)	4x HYDRO UNIT M 030T (20194176)	5x HYDRO UNIT M 030T (20194176)	6x HYDRO UNIT M 030T (20194176)	
			30,1	36	44	52	60,2	54	66	78	90,3	120,4	150,5	180,6	
20128431	2x POWER MAX 65 P	111,4	•	•	•	•		•							
20128432	2x POWER MAX 80 P	134		•	•	•	•	•	•						
20128433	2x POWER MAX 100	176,6				•	•	•	•	•					
20128434	2x POWER MAX 110	190,6				•	•	•	•	•	•				
20128435	2x POWER MAX 130	219,6					•		•	•	•				
20128436	2x POWER MAX 150	258							•	•	•	•			
20128433	3x POWER MAX 100	264,9								•	•	•			
20128434	3x POWER MAX 110	285,9								•	•	•			
20128435	3x POWER MAX 130	329,4									•	•	•		
20128436	3x POWER MAX 150	387										•	•	•	
20128433	4x POWER MAX 100	353,2									•	•	•		
20128434	4x POWER MAX 110	381,2										•	•	•	
20128435	4x POWER MAX 130	439,2										•	•	•	
20128436	4x POWER MAX 150	516											•	•	
20128435	5x POWER MAX 130	549											•	•	
20128436	5x POWER MAX 150	645												•	

(\*) The following combinations guarantee the best energy performance; for the full list of certified hybrid systems please refer to the company declaration.

## 2. BOILER ACCESSORIES

### 2.1 ACCESSORIES FOR POWER EVO-X BOILER

CODE	MODEL
<b>BOILER ACCESSORIES</b>	
1220559	Outdoor temperature probe kit with connector
20201490	LPG transformation kit (35/45 kW)
20201489	LPG transformation kit (55/70 kW)
20196701	Support frame
20190221	Shut-off cock
4031810	Condensate neutralizer N2 (up to 450 kW)
4031811	Condensate neutralizer HN2 (up to 280 kW)
<b>ACCESSORIES - STAND ALONE INSTALLATION</b>	
20195886	Connection pipe to hydraulic separator/plate heat exchanger <sup>(1)</sup>
20195884	Horizontal hydraulic separator
20195889	Internal 3 way valve kit <sup>(2)</sup>
20195890	External 3 way valve kit <sup>(3)</sup>
20195891	Delivery/return connection for direct installation
20195883	Safety kit manifold <sup>(4)</sup>
20199254	Safety valve 4,5 bar FF 3/4"x1" <sup>(5)</sup>
20195885	Cover for safety kit/hydraulic separator
20200070	Spacer kit for fixing to wall <sup>(6)</sup>
<b>ACCESSORIES - CASCADE INSTALLATION</b>	
20197000	Trains with isolation <sup>(7) (8)</sup>
20197001	Trains with isolation - B2B <sup>(7) (8)</sup>
20197005	Trains without isolation <sup>(7) (8)</sup>
20197006	Trains without isolation - B2B <sup>(7) (8)</sup>
20197634	Gas train kit for cascade installation 35-45 kW <sup>(7)</sup>
20197635	Gas train kit for cascade installation 55-70 kW <sup>(7)</sup>
20197639	Gas train kit for cascade installation 35-45 kW - B2B <sup>(7)</sup>
20197640	Gas train kit for cascade installation 55-70 kW - B2B <sup>(7)</sup>
20197007	2" 1/2 manifolds for cascade of 2 boilers
20197362	2" 1/2 manifolds for cascade of 1 boiler
20197366	Through flange kit 2"1/2 PN6
20197367	Blind flange kit 2"1/2 PN6
20197364	Condensate outlet kit for cascade boiler
20196449	Stub kit for safety device housing 2" 1/2
20197642	Hydraulic separator kit 2"1/2
20071190	Safety kit <sup>(9)</sup>
20197368	Safety valve up to 400 kW (4,5 bar)

## Heat Pump

# MONOBLOC WALL-HUNG HYBRID SYSTEM "MAX"

CODE	MODEL
20009486	Fuel shut-off valve (VIC) - ØG.1" <sup>(10)</sup> <sup>(12)</sup>
20009482	Fuel shut-off valve (VIC) - ØG.1" ½ <sup>(11)</sup> <sup>(12)</sup>
20197363	Manifolds and ramps cover for stand alone boiler
20129765	Fixed split system kit Ø80 mm 20129765
20197070	Adapter Ø80 to Ø110 mm
20196319	Ø80/110 mm - Rainproof vertical adapter 20196319
20137506	90° Ø80 mm bend
20137538	Air-intake kit B23
20062338	Cascade terminal Ø160 mm with condensate drain
20197583	Collector Ø160 mm for 1 boiler
20197582	Y-fitting Ø160/160 mm
20200265	Cascade and zone remote control <sup>(13)</sup>

(1) Prearranged for coupling with safety valve code 20199254.

(2) Can be combined with models 35-45 kW.

(3) Can be combined with plate heat exchanger kit for single boiler for DHW production.

(4) It contains a thermometer, pressure gauge, relief valve, safety pressure switch and VIC valve.

(5) Can be used in Italy in combination with the 35kW model only.

(6) Kit required for concentric rear wall outlet for 55-70 kW models.

(7) To be ordered for each storage tank in the cascade system (qty = no. boilers).

(8) Does not include the gas train

(9) Does not include the relief valve and VIC.

(10) Recommended up to maximum output of 131 kW, calculated considering gas supply pressure = 20 mbar.

(11) Recommended up to maximum output of 230 kW, calculated considering gas supply pressure = 20 mbar.

(12) Intervention temperature 97 °C - Capillary length 5 m.

(13) Allows management of: cascade system, solar thermal and up to 6 independent direct/mixed zones.

## 2.2 ACCESSORIES FOR POWER MAX BOILER

CODE	MODEL
<b>BOILER ACCESSORIES</b>	
20132778	External probe
20133102	Condensate outlet kit for stand alone boiler
20125034	Injection pump kit POWER MAX 100 - 110 - 130 (115 Hi) <sup>(1)</sup> <sup>(2)</sup>
20125035	Injection pump kit POWER MAX 130 <sup>(1)</sup> <sup>(2)</sup>
20125040	High head injection pump POWER MAX 150 <sup>(1)</sup> <sup>(4)</sup>
20131898	Stub kit with safety devices for stand alone boiler 65 to 150 <sup>(5)</sup>
20190221	Shut-off cock 1" ½
20131663	Frame kit for FRONT/B2B cascade <sup>(6)</sup>
20131664	Frame conversion kit for B2B cascade <sup>(6)</sup>
4031811	HN2 neutraliser kit up to 280 kW <sup>(7)</sup> <sup>(8)</sup>
4031810	N2 neutraliser kit up to 450 kW <sup>(7)</sup>
4031812	N3 neutraliser kit 450 to 1500 kW <sup>(7)</sup>
4031813	HN3 neutraliser kit 280 to 750 kW <sup>(7)</sup> <sup>(8)</sup>
<b>ACCESSORIES - STAND ALONE INSTALLATION</b>	
20131897	Horizontal hydraulic separator kit for POWER MAX stand alone boiler
20136823	Delivery/return fitting kit for direct installation (without hydraulic separator) <sup>(9)</sup>

CODE	MODEL
20131665	Conversion kit C type for POWER MAX 65 P - 80 P
20131668	Conversion kit C type for POWER MAX 100 - 110 - 130 (115 Hi) - 150
20131270	Spacer kit for fixing to wall <sup>(10)</sup>
20133224	Cover for safety kit/hydraulic separator unit for POWER MAX stand alone boiler
20213521	Kit remote control POWER MAX <sup>(11)</sup>
<b>ACCESSORIES - CASCADE INSTALLATION</b>	
20175716	Primary sensor <sup>(12)</sup>
20131267	Condensate outlet kit for cascade boilers <sup>(13)</sup>
20130658	Trains without isolation for POWER MAX 65 P - 80 P - 100 - 110 - 130 (115 Hi) - 150 <sup>(14)</sup>
20131122	Trains with isolation for POWER MAX 65 P - 80 P - 100 - 110 - 130 (115 Hi) - 150 <sup>(14) (18)</sup>
20131121	Trains without isolation for POWER MAX 150 (external pump) <sup>(15)</sup>
20131123	Trains without isolation for POWER MAX 150 (external pump) <sup>(15) (18)</sup>
20131787	Trains without isolation for POWER MAX 65 P - 80 P - 100 - 110 - 130 (115 Hi) - 150 B2B <sup>(16)</sup>
20131789	Trains without isolation INAIL per POWER MAX 65 P - 80 P - 100 - 110 - 130 (115 Hi) - 150 B2B <sup>(16) (18)</sup>
20131788	Trains without isolation for POWER MAX 150 (external pump) B2B <sup>(17)</sup>
20131790	Trains without isolation for POWER MAX 150 (external pump) B2B <sup>(17) (18)</sup>
20133220	Hydraulic manifold kit 3" flanged DN80 + GAS 2" threaded - for 1 frame <sup>(19)</sup>
20130220	Hydraulic manifold kit 3" flanged DN80 + GAS 2" threaded - for 2 frames (up to 485 kW) <sup>(20)</sup>
20130221	Hydraulic manifold kit 3" flanged DN80 + GAS 2" threaded - for 3 frames (up to 485 kW) <sup>(20)</sup>
20130222	Hydraulic manifold kit 5" flanged DN125 + GAS 3" threaded DN80 - for 2 frames (over 485 kW) <sup>(21)</sup>
20130223	Hydraulic manifold kit 5" flanged DN125 + GAS 3" threaded DN80 - for 3 frames (over 485 kW) <sup>(21)</sup>
20132377	Manifolds and ramps cover kit - for single POWER MAX in cascade application
20070903	Closing plug kit 3" <sup>(22)</sup>
20082190	Through flange kit 3"
20070907	Closing plug kit 5" <sup>(22)</sup>
20082191	Through flange kit 5"
20070910	Stub kit for housing 3" safety device <sup>(23)</sup>
20070912	Stub kit for housing 5" safety device <sup>(23)</sup>
20071190	Safety kit (safety valve not included and VIC)
20023104	Safety valve up to 460 kW (5,4 bar 3/4" F)
20023106	Safety valve up to 580 kW (5,4 bar 1" F)
20009486	Fuel shut-off valve (VIC) - Ø G.1" - TS=97°C - Capillare L=5 m <sup>(24)</sup>
20009482	Fuel shut-off valve (VIC) - Ø G.1" 1/2 - TS=97°C - Capillare L=5 m <sup>(25)</sup>
20009483	Fuel shut-off valve (VIC) - Ø G.2" - TS=97°C - Capillare L=5 m <sup>(26)</sup>
20061640	Fuel shut-off valve (VIC) - Ø G.3" - TS=97°C - Capillare L=5 m <sup>(27)</sup>
20131238	Adapter Ø80/110 mm <sup>(35) (28)</sup>
20062338	Cascade terminal Ø160 mm with condensate outlet
20131266	Collector array Ø160 mm for 1 boiler

## Heat Pump

# MONOBLOC WALL-HUNG HYBRID SYSTEM "MAX"

CODE	MODEL
20132391	Eccentric adapter Ø160/200 mm
20132381	Y fitting Ø160 / Ø160 (only available with B2B configuration)
20132384	Y fitting Ø160 / Ø200 (only available with B2B configuration)

- (1) For POWER MAX 65 P - 80 P models the pump is already present in the boiler.  
 (2) The pump, which can be housed in the boiler, offers a high residual head on POWER MAX 100-110 and with these boilers is also suitable in combination with the plate heat exchanger. If the pump is used with POWER MAX 130 (115 Hi), it can be combined with the hydraulic separator but not with the plate heat exchanger.  
 (3) When combined with POWER MAX 150, this circulation pump can be mounted inside the boiler and offers a very low residual head (10 mbar). It must ONLY be used in combination with the horizontal hydraulic separator code: 20131897.  
 (4) This circulation pump cannot be mounted inside the boiler, it must be installed beneath the boiler.  
 (5) Includes all the safety devices, including safety valve and VIC mandatory for the Italian market.  
 (6) The frame is necessary in case of installation with plate exchanger; if the frame kit is not fixed to the wall, it is necessary to buy also the kit for the use of the front and back frame code 20131664.  
 (7) Availability of the material at our warehouse: 30 working days from the order receipt date.  
 (8) Equipped with extraction pumps.  
 (9) Kit compatible with all POWER MAX models in case of presence of kit and without the need of hydraulic separator  
 (10) Kit necessary for wall rear concentric exhaust.  
 (11) Necessary for hourly programming of the heater and for programming of zones (also those managed by the additional zone kits). Code 20132366 - Available for boilers manufactured before 2024, check accessory compatibility  
 (12) No.1 pc. for each cascade system, to be connected to the main boiler, i.e. the one that controls the cascade system  
 (13) To be ordered for each storage tank in the cascade system (qty = no. boilers)  
 (14) To be ordered for each manifold-side boiler with pump or valve installed inside the boiler.  
 (15) To be ordered for each manifold-side boiler with pump or valve installed outside the boiler.  
 (16) To be ordered for each boiler opposite the manifolds with pump or valve installed inside the boiler.  
 (17) To be ordered for each boiler opposite the manifolds with pump or valve installed outside the boiler.  
 (18) The kits allow you to bypass the single thermal unit to proceed with its maintenance while the other thermal units continue to operate  
 (19) To be used for the BACK TO BACK configuration with no. 2 BOILERS; includes 3" flanged DN80 delivery/return manifolds, 2" threaded gas manifold, condensate outlet manifold.  
 (20) For use with maximum power up to 485 kW; includes 3" flanged DN80 delivery/return manifolds, 2" threaded gas manifold, condensate outlet manifold.  
 (21) For use with maximum power exceeding 485 kW; includes 5" flanged DN125 delivery/return manifolds, 3" flanged DN80 gas manifold, condensate outlet manifold.  
 (22) They allow the closure, on one side, of the gas collector and the two hydraulic collectors  
 (23) Intended for use in cascade systems without primary circuit circulating pump  
 (24) Recommended up to maximum output of 131 kW, calculated considering gas supply pressure = 20 mbar.  
 (25) Recommended up to maximum output of 230 kW, calculated considering gas supply pressure = 20 mbar.  
 (26) Recommended up to maximum output of 580 kW, calculated considering gas supply pressure = 20 mbar.  
 (27) Recommended up to maximum output of 1150 kW, calculated considering gas supply pressure = 20 mbar.  
 (28) Only necessary for the models POWER MAX 65 P - 80 P.

## 3. ACCESSORIES TO COMPLETE THE SYSTEM

### 3.1 HEAT PUMP ACCESSORIES

CODE	MODEL
20194933	Temperature probe for balancing tanks or zone 2 flow temperature or solar temperature

### 3.2 DHW HEATER ACCESSORIES

CODE	MODEL
20055206	Electric anode kit 1/2" <sup>(1)</sup>
20123850	Thermometer kit for DHW heater <sup>(1)</sup>
20123851	Curve kit for electronic anode <sup>(1)</sup>
4383504	Solar heat exchanger for IDRA HP 300 <sup>(2)</sup>
4383505	Solar heat exchanger for IDRA HP 500 <sup>(3)</sup>
20203248	Solar heat exchanger 0,8 m <sup>2</sup> per C-HP 150-300
20203246	Solar heat exchanger 1,2 m <sup>2</sup> per C-HP 500
20203245	Solar heat exchanger 1,9 m <sup>2</sup> per C-HP 800-1000

(1) Accessories for DHW heater of the IDRA DS series

(2) Accessories for DHW heater of the IDRA HP 300

(3) Accessories for DHW heater of the IDRA HP 500

**4. HI, COMFORT CONTROLS**

**3.1 HEAT PUMP ACCESSORIES**

CODE	MODEL
20193354	Hi, Comfort T100 Wi-Fi <sup>(1)</sup>
20193352	Hi, Comfort T100 Wi-Fi <sup>(2)</sup>

(1) With Hi, Comfort G100-W, included, for internet connection by means of ADSL Wi-Fi router.

(2) For cable connection to the boiler. Compatible for radio frequency connection with Hi, Comfort G100-W code 20193355 (accessory not included and necessary for internet connection via home ADSL modem).

# MONOBLOC WALL-HUNG HYBRID SYSTEM "MAX"

## BIVALENT HEATING SYSTEM WITH HEAT PUMP AND BOILER

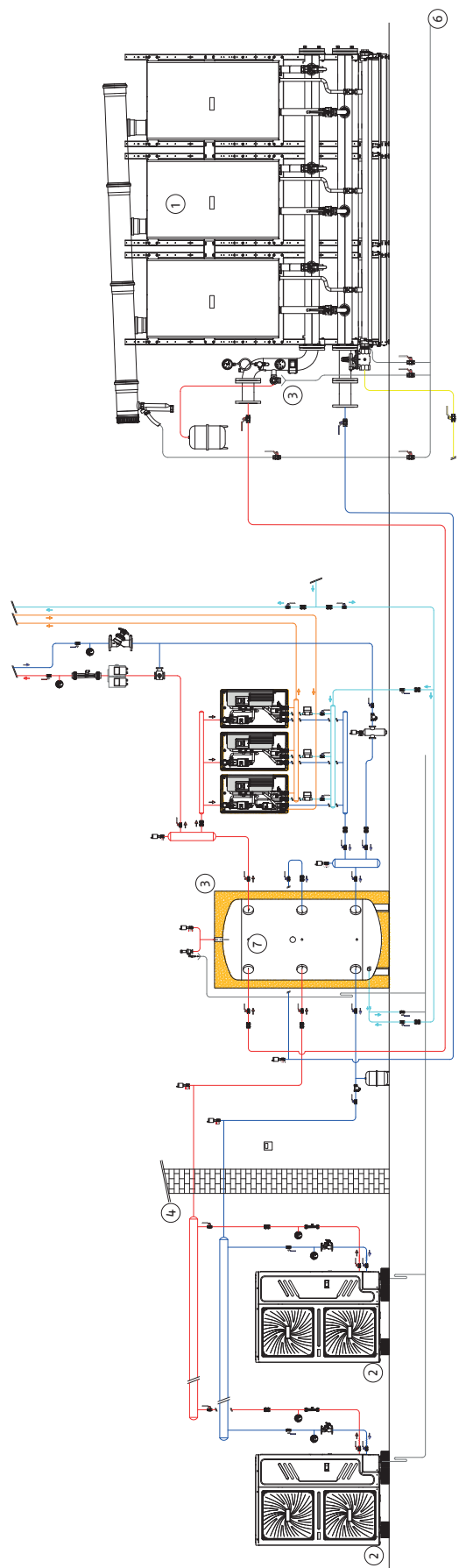

- (1) Condensing boiler POWER EVO-X / POWER MAX
- (2) Heat pump HYDRO UNIT M 010-16 or HYDRO UNIT M 018-030
- (3) Storage tank
- (4) External sensor for boiler thermoregulation
- (5) Safety stub
- (6) Condensate outlet
- (7) System sensor + cascade sensor + storage tank sensor

# MONOBLOC WALL-HUNG HYBRID SYSTEM "MAX"

## BIVALENT HEATING AND DHW PRODUCTION SYSTEM COMBINED WITH HEAT PUMP, BOILER AND SINGLE COIL STORAGE TANK

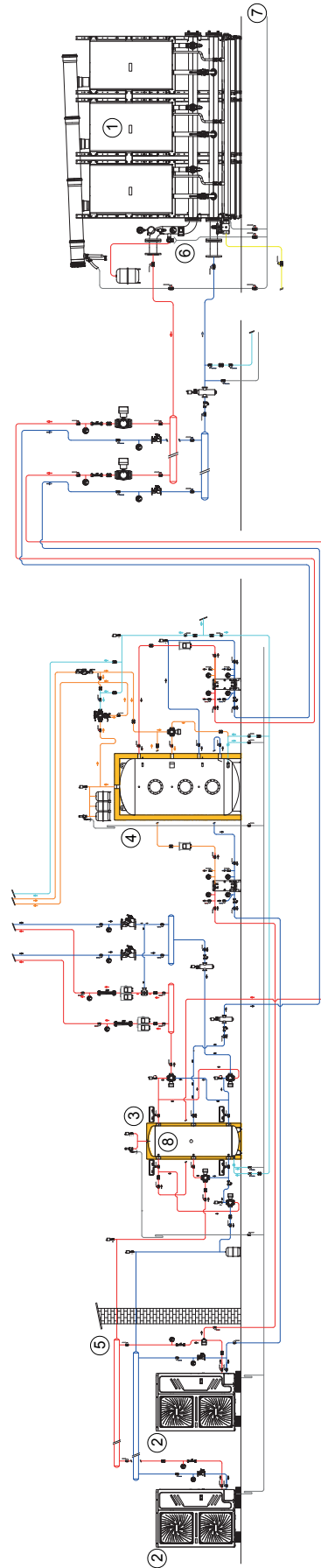

- (6) Safety stub
- (7) Condensate outlet

- (1) Condensing boiler POWER EVO-X / POWER MAX
- (2) Heat pump HYDRO UNIT M 010-:16 or HYDRO UNIT M 018-:030
- (3) Storage tank
- (4) DHW storage tank
- (5) External sensor for thermoregulation (supplied with the PdC)



- TOWER GREEN HYBRID + heat pump form a class A+ system
- Management of multiple energy sources: condensing boiler, hydronic heat pump for heating, cooling and domestic water
- Very high Modulation 1:10
- Low polluting emission: class 6 (UNI EN 15502)
- System zone circulating pumps: low consumption self-modulating with head up to 7 m (EEI≤0,20)
- Possibility to control up to 3 zones with kits that can be housed indoor
- Preset for connection to hydronic heat pump
- Remotely controllable interface equipped with ambient sensor
- 200-litre storage tank heater with double coil
- 8-litre domestic water expansion reservoir as standard
- Thermoregulation with external probe as standard
- Sanitary mixing valve as standard
- For gas conversion, please contact the authorised Beretta Technical Service Centres



## PRE-MIXED COMBINED BOILERS

CODE MTN <sup>(1)</sup>	MODEL	DIMENSIONS H x W x D (mm)	HEAT INPUT Min - Max (kW)	HEATER CAPACITY (litres)	ENERGY EFFICIENCY CLASS	
					(D→A+++)*	(F→A+)*
<b>INSTANTANEOUS COMBINED</b>						
20142498	TOWER GREEN Hybrid 35/200 BSI without solar	1900 x 600 x 775	3,5 - 35	200 double coil	A	A

(\*) HEATING: the energy efficiency class of the products ranges from D up to A+++ / DHW: the energy efficiency class of the products ranges from F up to A+

The boiler is complete with a hydraulic compensator with a direct low consumption zone.

The code Tower GREEN HE HYBRID does not include the heat pump: to be chosen according to the actual needs among the codes proposed in the combination tables.

(1) The Kasko formula is an option reserved for the boiler only.

**SPECIFIC ACCESSORIES FOR HYBRID BOX SYSTEM**

CODE	DESCRIPTION
20137523	Split system kit Ø80
20132018	Wall-hung flue gas collector Ø60-100 for indoor installations
20093833	Self-modulating circulating pump additional direct zone kit - suitable for cold
20093831	Self-modulating circulating pump additional motorised mixed zone kit - suitable for cold
20104496	25-litre cylindrical technical tank kit
20150823	Remote interface kit
20147627	Remote interface kit with release button
20171999	STOR H 50 - 50-litre inertial buffer tank
20142300	STOR H 100 - 100-litre technical hot/cold tank kit
20085223	Limit thermostat for low-temperature systems
20084749	Domestic water recirculation kit with circulating pump
20084750	Heating system and domestic water shut-off cock kit
20106843	Zone remote control panel with chronothermostat function <sup>(1)</sup>
20106844	Installation template kit
20097192	Condensate booster pump kit
20063872	ALPHA 7D weekly digital chronothermostat (86x86x20 mm)
20101748	ALPHA 7D WIRELESS weekly digital chronothermostat (86x86x20 mm)
20059639	ALPHA DGT digital thermostat (86x86x20 mm)
20059641	ALPHA DGT WIRELESS digital thermostat (86x86x20 mm)

(1) To use the additional zone chronothermostat, the device allows heating/cooling to be turned on only through time programming

**HI, COMFORT T100 COMMANDS FOR MANAGING DOMESTIC COMFORT VIA A SMARTPHONE OR TABLET <sup>(\*)</sup>**

CODE	DESCRIPTION
20193354	Hi, Comfort T100 Wi-Fi <sup>(1)</sup>
20193352	Hi, Comfort T100 <sup>(2)</sup>
20193355	Hi, Comfort G100-W
20193356	Hi, Comfort G100-R

(1) Includes Hi, Comfort G100-W for an Internet connection via an ADSL home wi-fi router.

(2) For wired connection to the boiler. Compatible for a radio frequency connection with Hi, Comfort G100-W code 20193355 (accessory not included, but necessary for the Internet connection via an ADSL home router).

(\*) Possibility of ON/OFF connection: for more info, refer to the pages dedicated to the Hi, Comfort T100 command in the THERMOSTATS AND TIMED THERMOSTATS section of the price list catalogue.

(3) If Hi, Comfort G100-W is available and the ADSL home wi-fi signal near the boiler is weak, the RF wireless receiver (supplied with kit 20101748 ALPHA 7 D WIRELESS) can be installed, connecting it in place of Hi, Comfort G100-W in the boiler. Hi, Comfort G100-W can then be brought closer to the ADSL home wi-fi router. In this case, the RF wireless receiver acts as an RF signal bridge and the ALPHA 7D is coupled with Hi, Comfort G100-W to maintain the wireless communication (ON/OFF installations only).

# Hybrid Combined Systems

## TOWER GREEN HE HYBRID

### ADDITIONAL ZONE CONFIGURATIONS

ZONE MANAGEMENT	CODE ADDITIONAL DIRECT ZONE 20093833	CODE ADDITIONAL MIXED ZONE 20093831
1 direct zone + 1 mixed zone	-	No. 1
1 direct zone + 2 mixed zones	-	No. 2
2 direct zones	No. 1	-
3 direct zones	No. 2	-
2 direct zones + 1 mixed zone	No. 1	No. 1

### HEAT PUMPS (COMPATIBLE WITH UNDERBOILER KIT AND KITS A, B AND C)

CODE	MODEL	DIMENSIONS H x W x D (mm)	HEAT. <sup>(1)</sup> /COOL. <sup>(2)</sup> OUTPUT (kW)	ENERGY EFFICIENCY CLASS (D → A+++)*	
				55°C	35°C
<b>SINGLE-PHASE HEAT PUMPS</b>					
20203411	HYDRO UNIT M 004	718 x 1295 x 426	4,20 / 4,50	A++	A+++
20203413	HYDRO UNIT M 006	718 x 1295 x 426	6,35 / 6,50	A++	A+++
20203414	HYDRO UNIT M 008	865 x 1385 x 523	8,40 / 8,30	A++	A+++

(\*) HEATING: the range of energy efficiency class of this products category is between D and A+++

(1) Outdoor air d.b. + 7 °C / w.b. + 6 °C, water 30°C - 35°C.

(2) Outdoor air d.b. + 35 °C/w.b. + 24°C, water 23°C - 18°C.

Models that can be used for stand-alone full electric installation with commands supplied as standard, and for hybrid systems in combination with the REC10MHC command (refer to the specific section).

CODE	MODEL	DIMENSIONS H x W x D (mm)	OUTPUT HEATING <sup>(1)</sup> /COOLING <sup>(2)</sup> (kW)	ENERGY EFFICIENCY CLASS (D → A+++)*	
				55°C	35°C
<b>SINGLE PHASE HEAT PUMPS</b>					
20198671	HYDRO UNIT P 004	927 x 946 x 400	3,95 / 4,00	A++	A+++
20198672	HYDRO UNIT P 006	927 x 946 x 400	5,80 / 6,15	A++	A+++
20198675	HYDRO UNIT P 008	927 x 946 x 400	7,60 / 8,00	A++	A+++

(\*) HEATING: the range of energy efficiency class of this products category is between D and A+++

(1) Outdoor air d.b. + 7 °C / w.b. + 6 °C, water 30 °C - 35 °C.

(2) Outdoor air d.b. + 35 °C/w.b. + 24 °C, water 23 °C - 18 °C

**TOWER GREEN HE HYBRID**

**SYSTEM DIAGRAM WITH TOWER GREEN HE HYBRID AND HEAT PUMP**

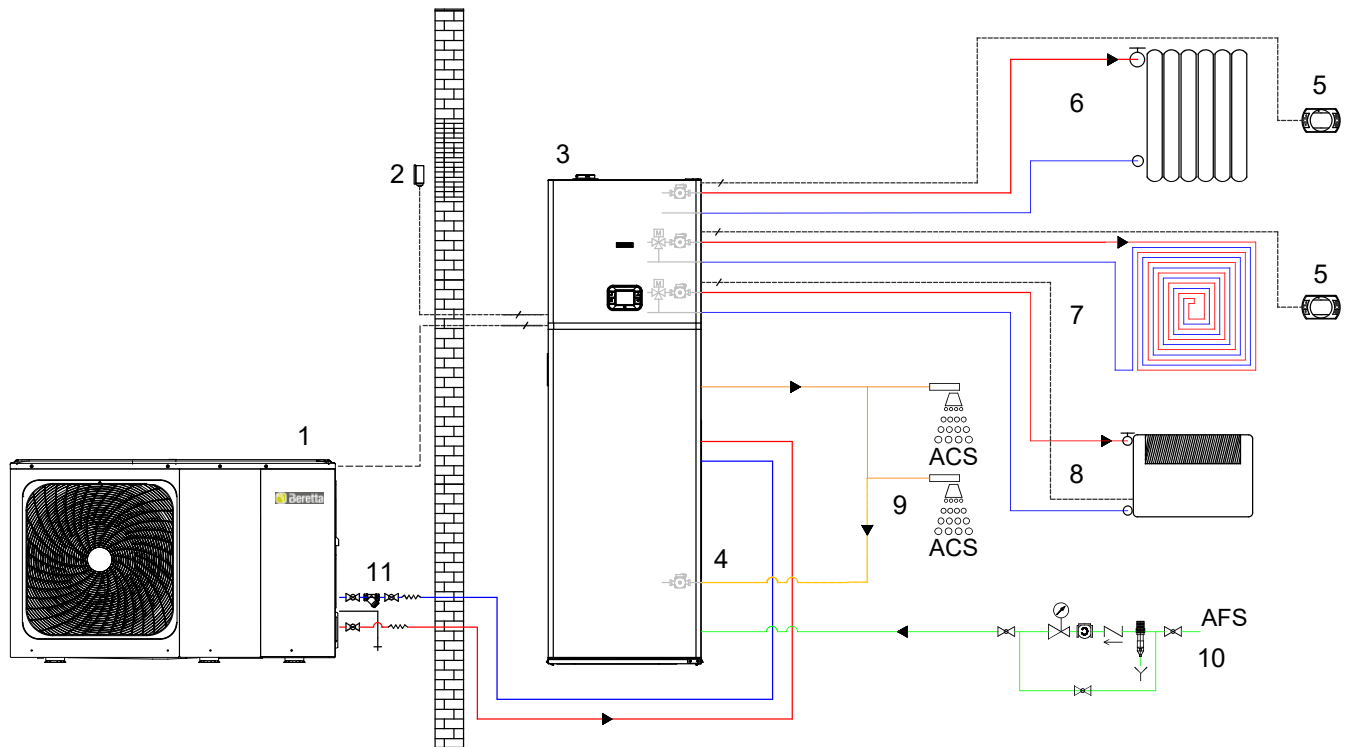

Basic layout purely for illustrative purposes

**KEY:**

- (1) Heat pump
- (2) External probe positioned north-north-west
- (3) TOWER GREEN HE HYBRID S 35/200 BSI floor-standing condensing boiler with one direct zone as standard and two optional mixed zones
- (4) Domestic water recirculation (optional accessory that can be installed on the boiler, consisting of a circulating pump with timer)
- (5) Hi, Comfort T100 command
- (6) Direct/high temperature zone (TIVANO fan coil or radiator)
- (7) Zone No. 1 mixed/low temperature (or direct) for floor-standing system
- (8) Zone No. 2 mixed/low temperature (or direct) for TIVANO fan coil
- (9) User/domestic hot water
- (10) DCW
- (11) Mesh filter



Combined Hybrid Systems  
**BERETTA HARMONY HYBRID**



- BERETTA HARMONY HYBRID is Beretta's factory-made multi-energy residential system: accessible, compact, and easy to install.
- Consisting of the BERETTA HARMONY 3.5 or 5.0(\*) kW heat pump outdoor unit in R32, the HYBRID HYDRAULIC KIT indoor unit, the CIAO X condensing boiler in a combined 25 or 30 kW version and the HI, COMFORT T300-HY system manager.
- Meeting heating, cooling, and domestic hot water needs in a single system for year-round home comfort.
- Compact and versatile solution designed to adapt to multiple system requirements, minimizing space requirements inside and outside the home: small hydronic kit that can be easily positioned either below or to the side of the boiler, up to a maximum distance of 15m; heat pump synonymous with compactness, with the option of floor or wall mounting with suitable support brackets, up to a maximum distance of 25m in length and 10m in height from the indoor unit.
- Plug&Play technology for simple, quick and flexible installation.
- Proprietary system intelligence stored in the system interface and also remotely manageable via the Hi, Comfort app.
- Attention to user needs and choice between economic optimization mode, for savings on energy bills, or eco mode, to help reduce CO2 emissions.
- Smart Grid Ready system, designed to work in synergy with modern smart energy distribution grids, and integrable with photovoltaic panels.

**HYBRID SYSTEMS FOR COMBINED BOILERS**

CODE	DESCRIPTION	COMFORT MANAGEMENT <sup>(1)</sup>	DHW MANAGEMENT	ZONE MANAGEMENT
20231687	BERETTA HARMONY HYBRID CIAO X 3.5 - 25	hot / cold		1 DIRECT
<b>COMPOSED BY:</b>				
20225096	BERETTA HARMONY 3.5			1 piece
20187761	CIAO X 25C			1 piece
20225097	HYBRID HYDRAULIC KIT			1 piece
20225099	HI, COMFORT T300-HY			1 piece
20231689	BERETTA HARMONY HYBRID CIAO X 3.5 - 30	hot / cold		1 DIRECT
<b>COMPOSED BY:</b>				
20225096	BERETTA HARMONY 3.5			1 piece
20187765	CIAO X 30C			1 piece
20225097	HYBRID HYDRAULIC KIT			1 piece
20225099	HI, COMFORT T300-HY			1 piece

CODE	DESCRIPTION	COMFORT MANAGEMENT <sup>(1)</sup>	DHW MANAGEMENT	ZONE MANAGEMENT
20231690	BERETTA HARMONY HYBRID CIAO X 5.0 - 25 <sup>(*)</sup>	hot / cold		1 DIRECT
<b>COMPOSED BY:</b>				
20225101	BERETTA HARMONY 5.0 <sup>(*)</sup>			1 piece
20187761	CIAO X 25C			1 piece
20225097	HYBRID HYDRAULIC KIT			1 piece
20225099	HI, COMFORT T300-HY			1 piece
20231691	BERETTA HARMONY HYBRID CIAO X 5.0 - 30 <sup>(*)</sup>	hot / cold		1 DIRECT
<b>COMPOSED BY:</b>				
20225101	BERETTA HARMONY 5.0 <sup>(*)</sup>			1 piece
20187765	CIAO X 30C			1 piece
20225097	HYBRID HYDRAULIC KIT			1 piece
20225099	HI, COMFORT T300-HY			1 piece

(\*) Available from 2026.

(1) Comfort management with boiler and heat pump. In heating mode, combined or alternating operation between boiler and heat pump. In cooling mode (hydronic), if fan coils are present in the system, heat pump operation.

Combined condensing boiler.

## HYBRID SYSTEM CONTROLS

CODE	DESCRIPTION
20225099	HI, COMFORT T300-HY

## HYBRID HYDRAULIC KIT <sup>(\*)</sup>

CODE	DESCRIPTION
20225097	HYBRID HYDRAULIC KIT

(\*) The connecting ramps between the hydraulic kit and the boiler are not supplied as standard.

## HEAT PUMPS

CODE	MODEL	DIMENSIONS HxWxD (mm)	HEATING				COOLING				ENERGY EFFICIENCY CLASS	
			Floor <sup>(1)</sup>		Fancoils <sup>(2)</sup>		Floor <sup>(3)</sup>		Fancoils <sup>(4)</sup>		(D→A+++)	
			Output (kW)	COP	Output (kW)	COP	Output (kW)	EER	Output (kW)	EER	55°C	35°C
20225096	BERETTA HARMONY 3.5	557x771x304	3,53	4,4	3,59	3,7	3,6	4,6	3,5	3,0	A <sup>+</sup>	A <sup>++</sup>
20225101	BERETTA HARMONY 5.0		<sup>(*)</sup> Available from 2026.									

(1) Heating: delivery water temperature 35 °C with thermal gradient 5K; outdoor air temperature 7 °C Tb.s and 6 °C Tb.u.

(2) Heating: delivery water temperature 45 °C with gradient 5K; outdoor air temperature 7 °C Tb.s and 6 °C Tb.u.

(3) Cooling: delivery water temperature 18 °C with water thermal gradient 5 °C; inlet air temp. 35 °C.

(4) Cooling: delivery water temperature 7 °C with water thermal gradient 5 °C; inlet air temp. 35 °C.

The energy class of the products ranges from D up to A+++

Combined Hybrid Systems  
**BERETTA HARMONY HYBRID**

**COMBINED CONDENSING BOILER (\*)**

CODE	MODEL	GAS	DIMENSIONS HxWxD (mm)	CH INPUT / DHW INPUT Min - Max (kW)	DHW PRODUCTION (l/ min-Δt 25°C)	ENERGY EFFICIENCY CLASS (6)	
						(D→A+++)	(F→A+)
<b>INSTANTANEOUS COMBI BOILERS</b>							
20187761	CIAO X 25C	NG	700 x 400 x 275	3,1-20,0/3,1-25,0	14,3	A	A
20187765	CIAO X 30C	NG	700 x 400 x 275	3,95-25,0/3,95-30,0	17,2	A	A
20187764	CIAO X 25C	LPG	700 x 400 x 275	3,95-25,0/3,95-30,0	17,2	A	A

For condensing boilers specific accessories, refer to the dedicated section for CIAO X 25 and 30 C boilers in the Product Catalogue.

(\*) The connecting ramps between the hydraulic kit and the boiler are not supplied as standard.

(5) The energy class of the products ranges from D up to A+++ / from F up to A+

**SYSTEM ACCESSORIES**

CODE	DESCRIPTION
1220559	External probe (6)
20104496	25-litre inertial storage kit (7)
20211852	Hi, Comfort T200 (8)

(6) Installation is always recommended.

(7) For systems with a volume of less than 20 liters, installation on the heating system return is recommended.

(8) Room thermostat which, when combined in RF to Hi, Comfort T300-Hy, allows zone management.

**COMBINABLE FAN COIL UNITS**

Please refer to the specific section in the Product Catalog.

**EXAMPLE OF A SYSTEM WITH A HYBRID WALL SYSTEM**

HEATING, COOLING, AND DHW SYSTEM WITH HEAT PUMP, HYDRAULIC KIT, AND COMBINED BOILER

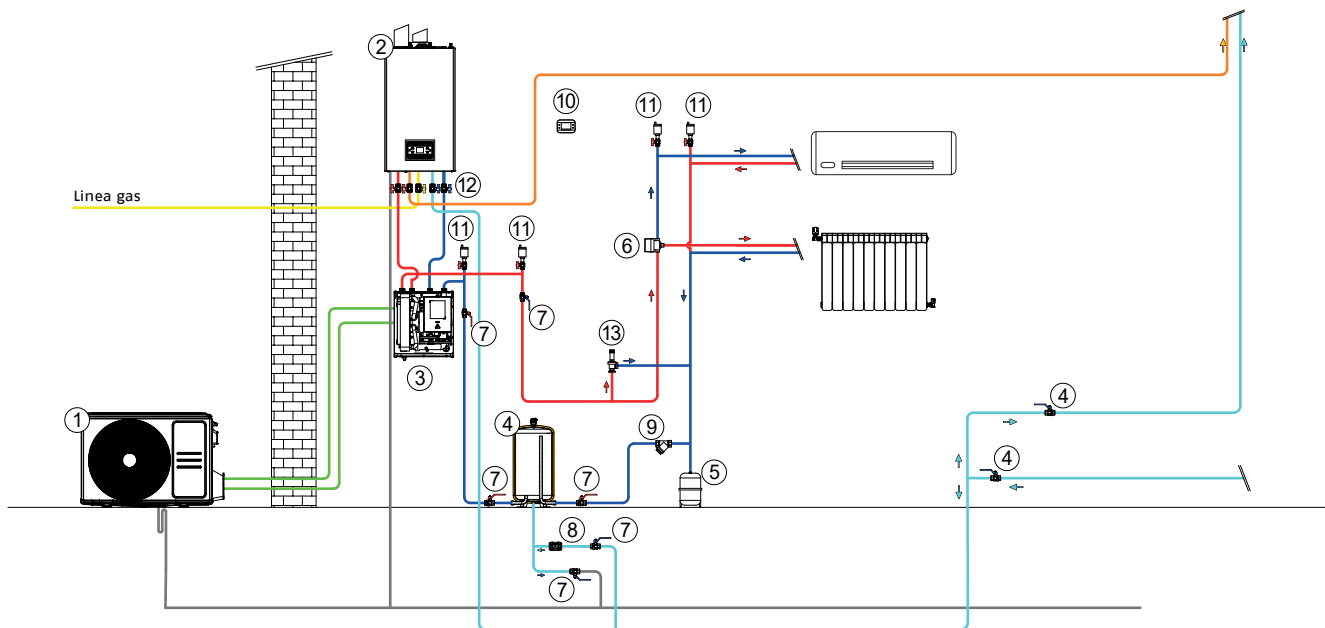

- |   |                              |
|---|------------------------------|
| (1) Heat pump outdoor unit                      | (8) Non-return valve         |
| (2) Boiler with circulator and vessel           | (9) Filter                   |
| (3) Heat pump indoor unit                       | (10) T300-Hy control panel   |
| (4) Inertial storage                            | (11) Deaerator               |
| (5) Expansion vessel                            | (12) Under-boiler tap kit    |
| (6) Summer-winter diverter valve <sup>(*)</sup> | (13) Adjustable bypass valve |
| (7) Globe valve                                 |                              |

(\*) The responsibility of the installer





- The system consists of 3 basic components: combined condensing boiler, EXCLUSIVE AGILE R32 heat pump and REC10MHC user interface (optional)
- The multi-energy hybrid system is suitable for room heating and domestic hot water production
- Possibility of solar integration
- Simple and intuitive REC10 I control with large backlit display, which allows the full parametrisation of the system as well as displaying the operating status
- Wide range of accessories

**COMBINED CONDENSING BOILERS (COMPATIBLE WITH UNDER-BOILER KITS AND KITS A, B AND C)**

CODICE MTN <sup>(1)</sup>	MODEL	GAS	DIMENSIONS H x W x D (mm)	HEAT INPUT OF HEAT. / DOMESTIC WATER Min - Max (kW)	domestic water production (l/min-Δt 25°C)	ENERGY EFFICIENCY CLASS	
						(D→A <sup>+++</sup> )*	(F→A <sup>+</sup> )*
<b>INSTANTANEOUS COMBINED</b>							
20206141	EXCLUSIVE EVO X 25C	MTN/GPL <sup>(1)</sup>	740 x 420 x 275	1,90 - 20,00	14,3	A	A
20206142	EXCLUSIVE EVO X 30C	MTN/GPL <sup>(1)</sup>	740 x 420 x 275	2,70 - 25,00	17,2	A	A
20206143	EXCLUSIVE EVO X 35C	MTN/GPL <sup>(1)</sup>	740 x 420 x 275	2,70 - 32,00	20,0	A	A
20205312	MYNUTE EVO X 25 C	MTN/GPL <sup>(1)</sup>	740 x 420 x 275	2,50 - 20,00	14,3	A	A
20205313	MYNUTE EVO X 30 C	MTN/GPL <sup>(1)</sup>	740 x 420 x 275	3,00 - 25,00	17,2	A	A
20205314	MYNUTE EVO X 35 C	MTN/GPL <sup>(1)</sup>	740 x 420 x 275	3,50 - 30,00	20,0	A	A
20197875	CIAO X 25C	MTN	740 x 420 x 275	3,1-20,0/3,1-25,0	14,3	A	A
20197877	CIAO X 25C	GPL	740 x 420 x 275	5,0-20,0/5,0-25,0	14,3	A	A
20197876	CIAO X 30C	MTN	740 x 420 x 275	3,95-25,0/3,95-30,0	17,2	A	A

(\*) HEATING: the energy efficiency class of the products ranges from D up to A+++ / DHW: the energy efficiency class of the products ranges from F up to A+  
 (1) Boilers in which gas switch-over, thanks to the new ACC combustion system, is carried out through electronic settings.

**WALL-HUNG SPLIT HEAT PUMPS**

CODE	DESCRIPTION	DIMENSIONS	HEATING				COOLING				ENERGY EFFICIENCY CLASS	
		Outdoor unit	Floor <sup>(1)</sup>		Fan coils <sup>(2)</sup>		Floor <sup>(3)</sup>		Fan coils <sup>(4)</sup>		(D → A+++)*	
		H x W x D (mm)	Nominal output (kW)	COP	Nominal output (kW)	COP	Nominal output (kW)	EER	Nominal output (kW)	EER	 35°C <sup>(5)</sup>	 55°C <sup>(6)</sup>
<b>WITHOUT ON BOARD BACK UP HEATER</b>												
20205784	SET EXCLUSIVE AGILE 4 KW M	712 x 1008 x 426	4,25	5,20	4,35	3,80	4,50	5,55	4,70	3,45	A+++	A++
20205786	SET EXCLUSIVE AGILE 6 KW M	712 x 1008 x 426	6,20	5,00	6,35	3,75	6,55	4,90	7,00	3,00	A+++	A++
20205788	SET EXCLUSIVE AGILE 8 KW M	865 x 1118 x 523	8,30	5,20	8,20	3,95	8,40	5,05	7,40	3,38	A+++	A++
20205791	SET EXCLUSIVE AGILE 10 KW M	865 x 1118 x 523	10,00	5,00	10,00	3,80	10,00	4,80	8,20	3,30	A+++	A++
20205793	SET EXCLUSIVE AGILE 12 KW M	865 x 1118 x 523	12,10	4,95	12,30	3,80	12,00	4,00	11,60	2,75	A+++	A++
20205800	SET EXCLUSIVE AGILE 14 KW M	865 x 1118 x 523	14,50	4,70	14,20	3,65	13,50	3,61	12,70	2,55	A+++	A++
20205804	SET EXCLUSIVE AGILE 12 KW T	865 x 1118 x 523	12,10	4,95	12,30	3,80	12,00	4,00	11,60	2,75	A+++	A++
20205806	SET EXCLUSIVE AGILE 14 KW T	865 x 1118 x 523	14,50	4,70	14,20	3,65	13,50	3,61	12,70	2,55	A+++	A++

(\*) HEATING: the range of energy efficiency class of this products category is between D and A+++

The performance is in accordance with standards EN 14511 and EN 14825.

(1) External air temperature 7°C D.B., 6°C W.B.; water inlet/outlet 30/35°C.

(2) External air temperature 7°C D.B., 6°C W.B.; water inlet/outlet 40/45°C.

(3) External air temperature 35°C; water inlet/outlet 23/18°C.

(4) External air temperature 35°C; water inlet/outlet 12/7°C.

(5) Value referred to the Average climate profile for delivery temperature of 35 °C. Values in accordance with Regulation 811/2013.

(6) Value referred to the Average climate profile for delivery temperature of 55 °C. Values in accordance with Regulation 811/2013.

## RES B COMBI WALL-HUNG SPLIT HYBRID SYSTEM

### MANAGEMENT CONTROL

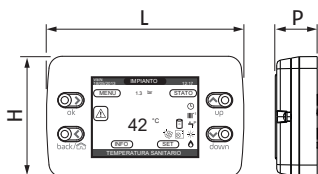

DESCRIPTION	DIMENSIONS H x W x D (mm)	NET WEIGHT (kg)
REC10MHC CONTROL	90 x 146 x 32	0,15

Note: The REC10MHC panel manages the operation of the new heat pump in a hybrid system.

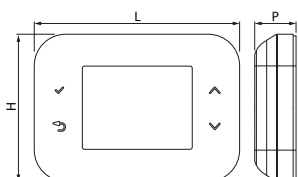

DESCRIPTION	DIMENSIONS H x W x D (mm)	NET WEIGHT (kg)
T300 Hi, Comfort Management control	95 X 132 X 95	0,15

### DOUBLE-COIL HEATERS (COMPATIBLE WITH KIT A)

CODE	MODEL	DIMENSIONS H x Ø (mm)	HEATER CAPACITY (litres)	DISPERSION (W)	ENERGY EFFICIENCY CLASS
<b>DOUBLE-COIL HEATERS</b>					
20117881	IDRA DS 200	1338 x 604	208 double coil	62	B
20117882	IDRA DS 300	1838 x 604	301 double coil	69	B
20117883	IDRA DS 430	1644 x 755	430 double coil	75	B

### SINGLE-COIL HEATERS (COMPATIBLE WITH UNDER-BOILER KIT AND KIT B)

CODE	MODEL	DIMENSIONS H x Ø (mm)	HEATER CAPACITY (litres)	DISPERSION (W)	ENERGY EFFICIENCY CLASS
<b>SINGLE-COIL HEATERS FOR HEAT PUMP</b>					
20117745	IDRA HP 300	1615 x 600	263 single-coil	85	C
20117746	IDRA HP 500	1690 x 750	470 single-coil	112	C
20204198	IDRA C-HP 150 MS	1138 x 604	170 single-coil	55	B
20204200	IDRA C-HP 200 MS	1354 x 604	210 single-coil	58	B
20204202	IDRA C-HP 300 MS	1838 x 604	305 single-coil	68	B
20204204	IDRA C-HP 500 MS	1793 x 755	500 single-coil	84	B

**INERTIAL BUFFER TANKS (COMPATIBLE WITH UNDER-BOILER KIT AND KITS A, B AND C)**

CODE	MODEL	DIMENSIONS H x Ø (mm)	HEATER CAPACITY (litres)	DISPERSION (W)	ENERGY EFFICIENCY CLASS
<b>SINGLE-COIL HEATERS FOR HEAT PUMP</b>					
20171999	STOR H 50 - 50-litre inertial buffer tank <sup>(1)</sup>	H x W x D 1080 x 470 x 250	50	-	-
20142300	STOR H 100 - 100-litre technical hot/cold tank kit <sup>(1)</sup>	H x W x D 920 x 500 x 450	100	-	-
20056180	STOR H 200	1395 x 550	203	68	C
20056181	STOR H 300	1560 x 600	277	82	C

(1) Provide at least 3,5 litres per kW of heat pump cooling output.

**SOLAR COLLECTORS (FOR KIT A ONLY)**

CODE	DESCRIPTION	MODEL
20201328	Sealed solar collector - 2,5 m <sup>2</sup>	SCF-25/4B A
20201335	Sealed solar collector - 2 m <sup>2</sup>	SCF-20/4B A

Note: for bracket codes and glycol refer to the solar thermal section.

**GUIDE TO SYSTEM CONFIGURATION**

**1. BOILER-HEAT PUMP COMBINATIONS**
**2. WALL-HUNG BOILER ACCESSORIES**
**3. ACCESSORIES TO COMPLETE THE SYSTEM**

3.1 Connect Hybrid

3.2 Built-in installation for Connect Hybrid

3.3 Hydraulic accessories

3.4 Electrical accessories

**1. BOILER-HEAT PUMP COMBINATIONS (RECOMMENDED)\***

Wall-hung boilers		Heat pumps							
INSTANTANEOUS COMBINED HEATING AND DOMESTIC WATER VERSION		Single-phaseW						Three-phase	
		SET AGILE 4 KW M	SET AGILE 6 KW M	SET AGILE 8 KW M	SET AGILE 10 KW MW	SET AGILE 12 KW M	SET AGILE 14 KW M	SET AGILE 12 KW T	SET AGILE 14 KW T
CODE	MODEL	20205784	20205786	20205788	20205791	20205793	20205800	20205804	20205806
20206141	EXCLUSIVE EVO X 25C	•	•	•					
20206142	EXCLUSIVE EVO X 30C	•	•	•	•	•		•	
20206143	EXCLUSIVE EVO X 35C	•	•	•	•	•	•	•	•
20205312	MYNUTE EVO X 25 C	•	•	•					
20205313	MYNUTE EVO X 30 C	•	•	•	•	•		•	
20205314	MYNUTE EVO X 35 C	•	•	•	•	•	•	•	•
20197875	CIAO X 25C	•	•	•					
20197877	CIAO X 25C	•	•	•					
20197876	CIAO X 30C	•	•	•	•	•		•	

(\*) The following combinations guarantee the best energy performance; for the full list of certified hybrid systems please refer to the company declaration. Combine the built-in box code 20130808 only with CONNECT HYBRID code 20130801, 20130802 and 20130803.

## 2. WALL-HUNG BOILER ACCESSORIES

CODE	DESCRIPTION
<b>ACCESSORIES</b>	
20016681	EDILBOX built-in box <sup>(1)</sup>
1103289	BOX for recessed IN-BOX installation <sup>(2)(3)(4)</sup>
20156799	Frost protection heating element kit B (down to -15°C) for combined versions (down to -15°C)
20132005	Wall-mounted hydraulic connections and gas tap kit
20133516	Wall-mounted hydraulic connections and heating, gas and DHW taps kit
20134477	Connections kit for IN-BOX installation for combined versions
20196582	Rigid ramps for EDILBOX - 25 kW <sup>(5)</sup>
20196580	Rigid ramps for BOX GREEN - 25 kW <sup>(5)</sup>
20196581	Rigid ramps for BOX GREEN - 30 kW <sup>(5)</sup>
20191518	Kit polyphosphates dispenser (compact)
20191517	Kit magnetic filter (compact)

(1) BOX compatible with Mynute X Box 25 C via specific accessory kit for built-in code 20196582.

(2) Paintable box.

(3) The front of the BOX (door) protrudes 26 mm from the recessed frame.

(4) BOX compatible with Mynute X Box 25 C and Mynute X Box 30 C respectively through the specific accessory kits for built-in cod. 20196580 and 20196581.

(5) The 'RIGID RAMPS' kits must be used in conjunction with the accessories Compact magnetic filter kit cod. 20191517 and Polyphosphate dosing compact kit cod. 20191518.

## 3. ACCESSORIES TO COMPLETE THE SYSTEM

### 3.1 CONNECT HYBRID

CODE	DESCRIPTION	ZONES	DIMENSIONS H x W x D (mm)
20130801	CONNECT HYBRID 1D <sup>(1)</sup>	1 direct zone	see BOX
20130802	CONNECT HYBRID 2D <sup>(1)</sup>	2 direct zones	see BOX
20130803	CONNECT HYBRID AT/BT <sup>(1)</sup>	1AT/BT (motorized)	see BOX

(1) Supplied without built-in Box (code 20130808), for the installation it is necessary to purchase it.

### 3.2 BUILT-IN INSTALLATION FOR CONNECT HYBRID

CODE	DESCRIPTION
20130808	Box (also for built-in installation) for CONNECT HYBRID <sup>(1)</sup>
20131752	Cock Kit for CONNECT HYBRID

(1) Paintable box.

**3.3 HYDRAULIC ACCESSORIES**

CODE	DESCRIPTION
20035644	Solar diverter mixing valve
20116162	7.5 m CONNECT SOLAR R - only return hydraulic group
20175281	1" Y water filter
20165227	Hybrid hydr. distr. hydraulic module 1 DIR
20203742	1" & 1 ¼" DHW diverting valve without temperature probe

**3.4 ELECTRICAL ACCESSORIES**

CODE	DESCRIPTION
20168672	Solar thermal unit interface kit <sup>(1)</sup>
1220559	Outdoor temperature probe kit with connector <sup>(1)</sup>

(1) Allows visualization of the operating status of the solar system on the REC10MHC system interface.

# RES B COMBI WALL-HUNG SPLIT HYBRID SYSTEM

## ONE-ZONE HEATING, COOLING AND DHW PRODUCTION SYSTEM COMBINED WITH SPLIT HEAT PUMP AND BOILER

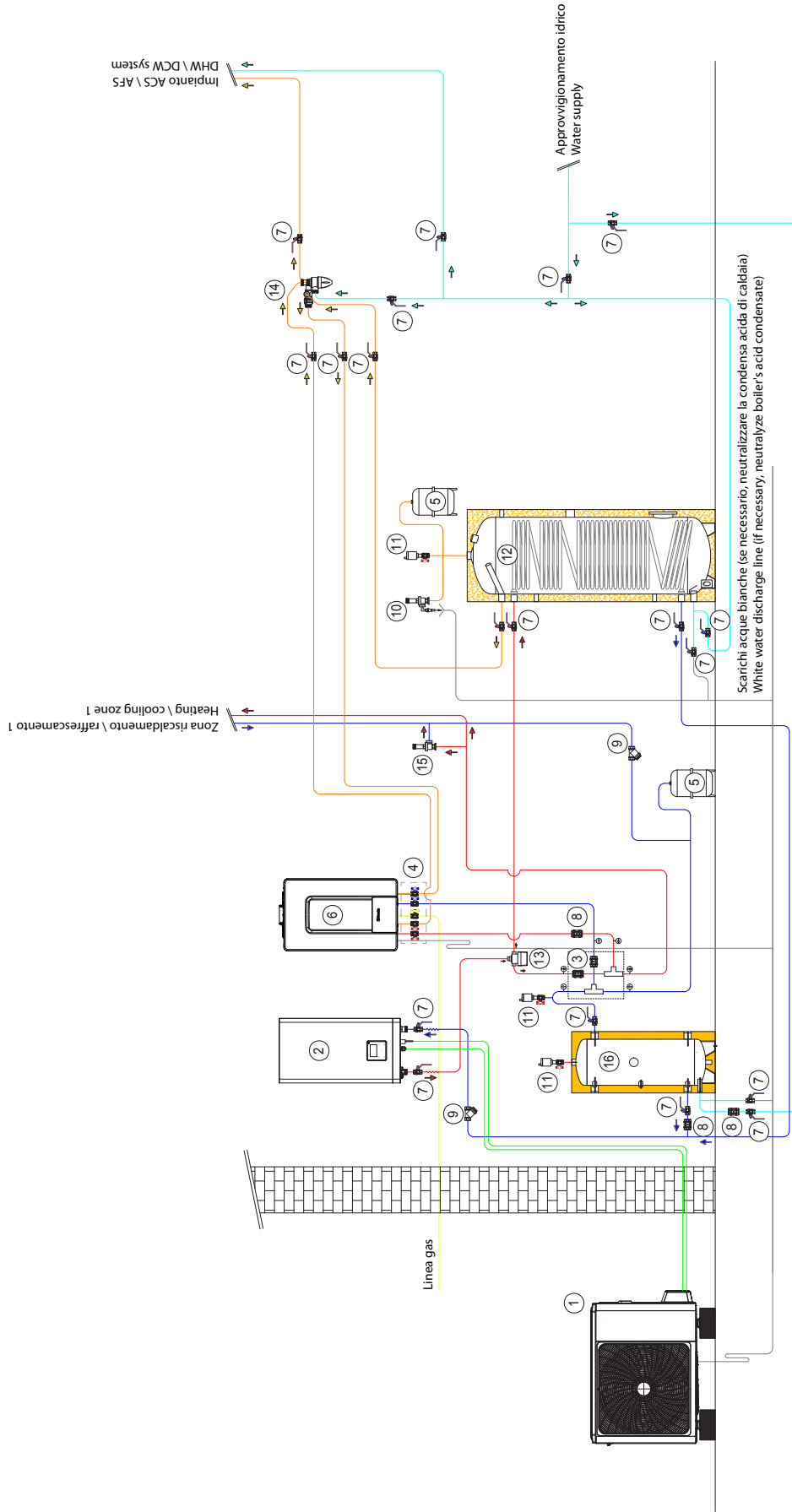

- (1) Heat pump outdoor unit
- (2) Heat pump indoor unit with circulator and reservoir
- (3) Hydraulic module with non-return valves
- (4) Under-boiler cock kit
- (5) Expansion reservoir
- (6) Boiler with circulator and reservoir
- (7) Shut-off valve
- (8) Non-return valve
- (9) Filter
- (10) Safety valve
- (11) Deaerator
- (12) DHW heater
- (13) DHW diverter valve
- (14) DHW mixer
- (15) By-pass valve
- (16) Storage tank

Scarichi acque bianche (se necessario, neutralizzare la condensa acida di caldaia)  
White water discharge line (if necessary, neutralize boiler's acid condensate)



Heating-only Hybrid systems

## RES B HEATING-ONLY WALL-HUNG SPLIT HYBRID SYSTEM



- The system consists of 3 basic components: heating-only condensing boiler, EXCLUSIVE AGILE R32 heat pump and REC10MHC user interface (optional)
- The multi-energy hybrid system is suitable for room heating and domestic hot water production
- Possibility of solar integration
- Simple and intuitive REC10MHC control with large backlit display, which allows the full parametrisation of the system as well as displaying the operating status
- Wide range of accessories



### HEATING-ONLY CONDENSING BOILERS (COMPATIBLE WITH UNDER-BOILER KIT AND KITS D AND E)

CODE	MODEL	GAS	DIMENSIONS H x W x D (mm)	HEAT OUTPUT HEAT. /DOMESTIC WATER Min - Max (kW)	ENERGY EFFICIENCY CLASS	
					(D→A <sup>+++</sup> )*	(F→A <sup>+</sup> )*
<b>HEATING-ONLY VERSION</b>						
20206144	EXCLUSIVE EVO X 25R	MTN/GPL <sup>(1)</sup>	740 x 420 x 275	1,9 - 20,0 / 1,9 - 25,0	A	-
20206145	EXCLUSIVE EVO X 35R	MTN/GPL <sup>(1)</sup>	740 x 420 x 275	2,7 - 32,0 / 2,7 - 34,9	A	-
20205315	MYNUTE EVO X 20 R	MTN/GPL <sup>(1)</sup>	740 x 420 x 275	2,5 - 20,0 / 2,5 - 20,0	A	-
20205316	MYNUTE EVO X 30 R	MTN/GPL <sup>(1)</sup>	740 x 420 x 275	3,5 - 30,0 / 3,5 - 34,9	A	-
20187766	CIAO X 15 R	MTN	740 x 420 x 275	3,1-15,0 / 3,1-25,0	A	-
20187767	CIAO X 25R	MTN	740 x 420 x 275	3,1-20,0 / 3,1-25,0	A	-

(\*) HEATING: the energy efficiency class of the products ranges from D up to A+++ / DHW: the energy efficiency class of the products ranges from F up to A+

(1) In EXCLUSIVE EVO X R boilers gas switch-over, thanks to the new ACC combustion system, is carried out through electronic settings.

**WALL-HUNG SPLIT HEAT PUMPS**

CODE	DESCRIPTION	DIMENSIONS		HEATING				COOLING			CLASS		
		Outdoor unit		Floor <sup>(1)</sup>		Fan coils <sup>(2)</sup>		Floor <sup>(3)</sup>		Fan coils <sup>(4)</sup>		(D → A+++)*	
		H x W x D (mm)	Nominal output (kW)	COP	Nominal output (kW)	COP	Nominal output (kW)	EER	Nominal output (kW)	EER	<sup>5</sup>	<sup>6</sup>	
<b>WITHOUT ON BOARD BACK UP HEATER</b>													
20205784	SET EXCLUSIVE AGILE 4 KW M	712 x 1008 x 426	4,25	5,20	4,35	3,80	4,50	5,55	4,70	3,45	A+++	A++	
20205786	SET EXCLUSIVE AGILE 6 KW M	712 x 1008 x 426	6,20	5,00	6,35	3,75	6,55	4,90	7,00	3,00	A+++	A++	
20205788	SET EXCLUSIVE AGILE 8 KW M	865 x 1118 x 523	8,30	5,20	8,20	3,95	8,40	5,05	7,40	3,38	A+++	A++	
20205791	SET EXCLUSIVE AGILE 10 KW M	865 x 1118 x 523	10,00	5,00	10,00	3,80	10,00	4,80	8,20	3,30	A+++	A++	
20205793	SET EXCLUSIVE AGILE 12 KW M	865 x 1118 x 523	12,10	4,95	12,30	3,80	12,00	4,00	11,60	2,75	A+++	A++	
20205800	SET EXCLUSIVE AGILE 14 KW M	865 x 1118 x 523	14,50	4,70	14,20	3,65	13,50	3,61	12,70	2,55	A+++	A++	
20205804	SET EXCLUSIVE AGILE 12 KW T	865 x 1118 x 523	12,10	4,95	12,30	3,80	12,00	4,00	11,60	2,75	A+++	A++	
20205806	SET EXCLUSIVE AGILE 14 KW T	865 x 1118 x 523	14,50	4,70	14,20	3,65	13,50	3,61	12,70	2,55	A+++	A++	

(\*) HEATING: the range of energy efficiency class of this products category is between D and A+++

The performance is in accordance with standards EN 14511 and EN 14825.

(1) External air temperature 7°C D.B., 6°C W.B.; water inlet/outlet 30/35°C.

(2) External air temperature 7°C D.B., 6°C W.B.; water inlet/outlet 40/45°C.

(3) External air temperature 35°C; water inlet/outlet 23/18°C.

(4) External air temperature 35°C; water inlet/outlet 12/7°C.

(5) Value referred to the Average climate profile for delivery temperature of 35 °C. Values in accordance with Regulation 811/2013.

(6) Value referred to the Average climate profile for delivery temperature of 55 °C. Values in accordance with Regulation 811/2013.

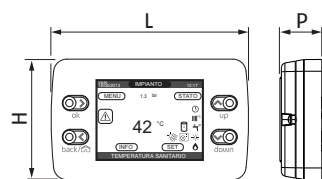
**MANAGEMENT CONTROL**

DESCRIPTION	DIMENSIONS H x W x D (mm)	NET WEIGHT (kg)
REC10MHC CONTROL	90 x 146 x 32	0,15

Note: The REC10MHC panel manages the operation of the new heat pump in a hybrid system.

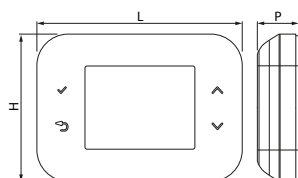

DESCRIPTION	DIMENSIONS H x W x D (mm)	NET WEIGHT (kg)
T300 Hi, Comfort Management control	95 X 132 X 95	0,15

## RES B HEATING-ONLY WALL-HUNG SPLIT HYBRID SYSTEM

### DOUBLE-COIL HEATERS

CODE	MODEL	DIMENSIONS H x Ø (mm)	HEATER CAPACITY (litres)	DISPERSION (W)	CLASS
<b>DOUBLE-COIL HEATERS</b>					
20117881	IDRA DS 200	1338 X 604	208 double coil	62	B
20117882	IDRA DS 300	1838 X 604	301 double coil	69	B

### SINGLE-COIL HEATERS

CODE	MODEL	DIMENSIONS H x Ø (mm)	HEATER CAPACITY (litres)	DISPERSION (W)	CLASS
<b>SINGLE-COIL HEATERS FOR HEAT PUMP</b>					
20117745	IDRA HP 300	1615 x 600	263 single-coil	85	C
20117746	IDRA HP 500	1690 x 750	470 single-coil	112	C
20204198	IDRA C-HP 150 MS	1138 x 604	170 single-coil	55	B
20204200	IDRA C-HP 200 MS	1354 x 604	210 single-coil	58	B
20204202	IDRA C-HP 300 MS	1838 x 604	305 single-coil	68	B
20204204	IDRA C-HP 500 MS	1793 x 755	500 single-coil	84	B

### INERTIAL BUFFER TANKS

CODE	MODEL	DIMENSIONS H x Ø (mm)	HEATER CAPACITY (litres)	DISPERSION (W)	CLASS
<b>SINGLE-COIL HEATERS FOR HEAT PUMP</b>					
20171999	STOR H 50 - 50-litre inertial buffer tank <sup>(1)</sup>	H x W x D 1080 x 470 x 250	54	-	C
20142300	STOR H 100 - 100-litre technical hot/cold tank kit <sup>(1)</sup>	H x W x D 920 x 500 x 450	100	-	-
20056180	STOR H 200	1395 x 550	203	68	C
20056181	STOR H 300	1560 x 600	277	82	C

(1) Provide at least 3.5 litres per kW of heat pump cooling output.

### SOLAR COLLECTORS

CODE	DESCRIPTION	MODEL
20201328	Sealed solar collector - 2,5 m <sup>2</sup>	SCF-25/4B A
20201335	Sealed solar collector - 2 m <sup>2</sup>	SCF-20/4B A

Note: for bracket codes and glycol refer to the solar thermal section.

**GUIDE TO SYSTEM CONFIGURATION**



**1. BOILER-HEAT PUMP COMBINATIONS**

**2. WALL-HUNG BOILER ACCESSORIES**

**3. ACCESSORIES TO COMPLETE THE SYSTEM**

3.1 Connect Hybrid

3.2 Built-in installation for Connect Hybrid

3.3 Hydraulic accessories

3.4 Electrical accessories

**1. BOILER-HEAT PUMP COMBINATIONS (RECOMMENDED)\***

Wall-hung boilers		Heat pumps							
INSTANTANEOUS COMBINED HEATING AND DOMESTIC WATER VERSION		Single-phase				Three-phase			
		SET EXCLUSIVE AGILE 4 KW M	SET EXCLUSIVE AGILE 6 KW M	SET EXCLUSIVE AGILE 8 KW M	SET EXCLUSIVE AGILE 10 KW M	SET EXCLUSIVE AGILE 12 KW M	SET EXCLUSIVE AGILE 14 KW M	SET EXCLUSIVE AGILE 12 KW T	SET EXCLUSIVE AGILE 14 KW T
CODE	MODEL	20205784	20205786	20205788	20205791	20205793	20205800	20205804	20205806
20206144	EXCLUSIVE EVO X 25R	•	•	•					
20206145	EXCLUSIVE EVO X 35R	•	•	•	•	•	•	•	•
20205315	MYNUTE EVO X 20 R	•	•	•					
20205316	MYNUTE EVO X 30 R	•	•	•	•	•		•	
20187766	CIAO X 15 R	•	•						
20187767	CIAO X 25R	•	•	•					

(\*) The following combinations guarantee the best energy performance; for the full list of certified hybrid systems please refer to the company declaration. Combine the built-in box code 20130808 only with CONNECT HYBRID code 20130801, 20130802 and 20130803.

## RES B HEATING-ONLY WALL-HUNG SPLIT HYBRID SYSTEM

### 2. WALL-HUNG BOILER ACCESSORIES

CODE	DESCRIPTION
<b>ACCESSORIES</b>	
1103289	GREEN built-in BOX with door <sup>(1)(2)(3)</sup>
20058454	Built-in cabinet for HYBRID BOX and SOLAR BOX <sup>(4)</sup> - Dimensions in mm 2200 x 950 x 350
20134477	Connections kit for IN-BOX installation for combined versions
20196581	Rigid ramps for BOX GREEN - 30 kW <sup>(4)(5)</sup>
20191518	Kit polyphosphates dispenser (compact)
20191517	Kit magnetic filter (compact)

(1) Paintable box.

(2) The front of the BOX (door) protrudes 26 mm from the recessed frame.

(3) BOX compatible with and Mynute X 30 C respectively through the specific accessory kits for built-in cod. 20196580 and 20196581.

(4) In case of boiler models only heating, the hydraulic fittings and ramps contained in the reference kit do not need application.

(5) The 'RIGID RAMPS' kits must be used in conjunction with the accessories Compact magnetic filter kit cod. 20191517 and Polyphosphate dosing compact kit cod. 20191518.

### 3. ACCESSORIES TO COMPLETE THE SYSTEM

#### 3.1 CONNECT HYBRID

CODE	DESCRIPTION	ZONES	DIMENSIONS H x W x D (mm)
20130801	CONNECT HYBRID 1D <sup>(1)</sup>	1 direct zone	see BOX
20130802	CONNECT HYBRID 2D <sup>(1)</sup>	2 direct zones	see BOX
20130803	CONNECT HYBRID AT/BT <sup>(1)</sup>	1AT/BT (motorized)	see BOX

(1) Supplied without built-in Box (code 20130808), for the installation it is necessary to purchase it.

#### 3.2 BUILT-IN INSTALLATION FOR CONNECT HYBRID

CODE	DESCRIPTION
20130808	Box (also for built-in installation) for CONNECT HYBRID <sup>(1)</sup>
20131752	Cock Kit for CONNECT HYBRID

(1) Paintable box.

**3.3 HYDRAULIC ACCESSORIES**

CODE	DESCRIPTION
1150529	Mixing valve 3/4"
20035644	Solar diverter mixing valve
20116162	7.5 m CONNECT SOLAR R - only return hydraulic group
20175281	1" Y water filter
20165227	Hybrid hydr. distr. hydraulic module 1 DIR
20203742	1" & 1 1/4" DHW diverting valve without temperature probe

**3.4 ELECTRICAL ACCESSORIES**

CODE	DESCRIPTION
20168672	Solar thermal unit interface kit <sup>(1)</sup>
1220559	Outdoor temperature probe kit with connector <sup>(1)</sup>

(1) Allows visualization of the operating status of the solar system on the REC10MHC system interface.

# RES B HEATING-ONLY WALL-HUNG SPLIT HYBRID SYSTEM

## MONOVALENT TWO-ZONE HEATING AND DHW PRODUCTION SYSTEM COMBINED WITH SPLIT HEAT PUMP, AND BOILER

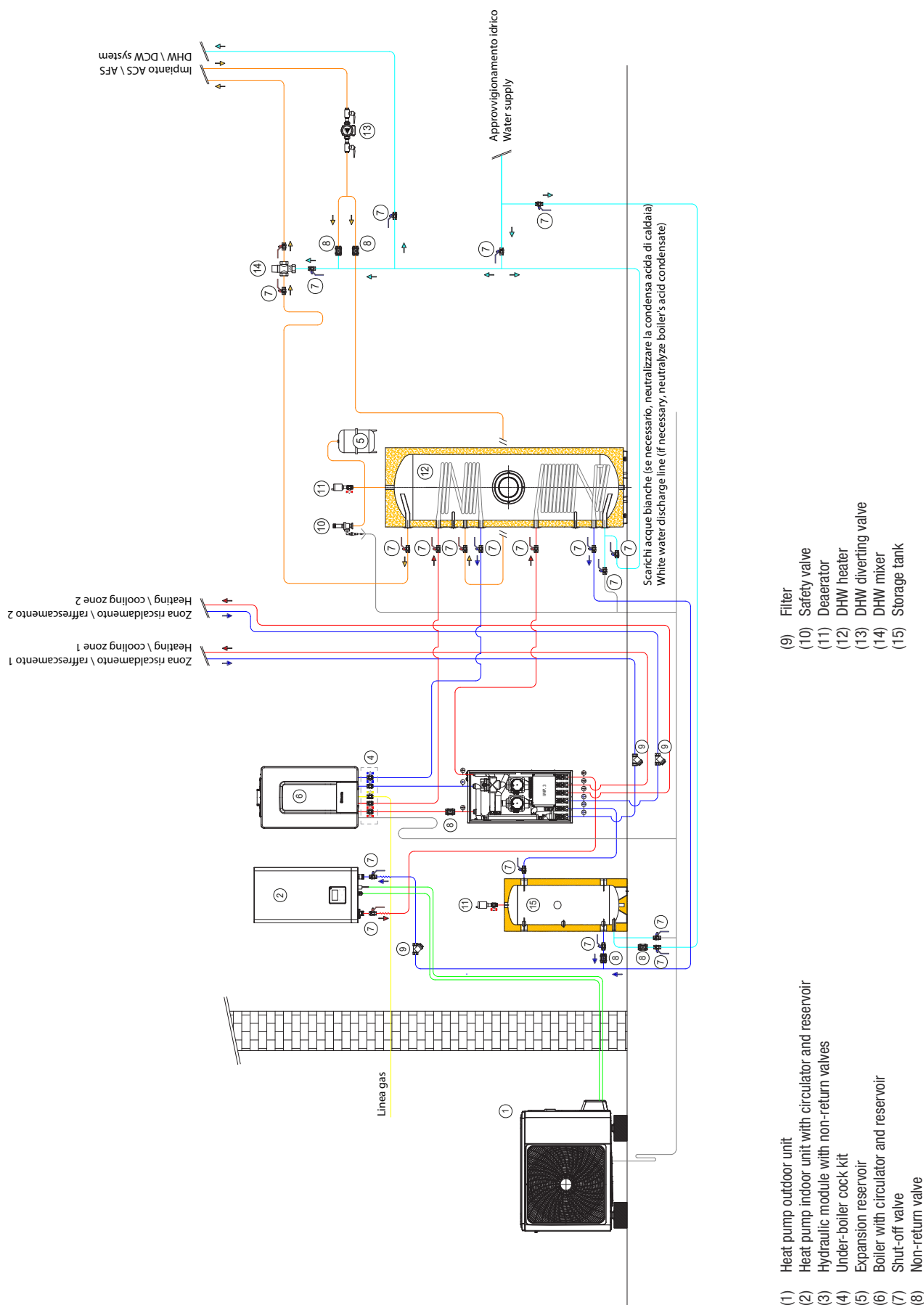

RES B HEATING-ONLY WALL-HUNG SPLIT HYBRID SYSTEM

MONOVALENT TWO-ZONE HEATING AND DHW PRODUCTION SYSTEM COMBINED WITH SPLIT HEAT PUMP, BOILER AND SOLAR SYSTEM

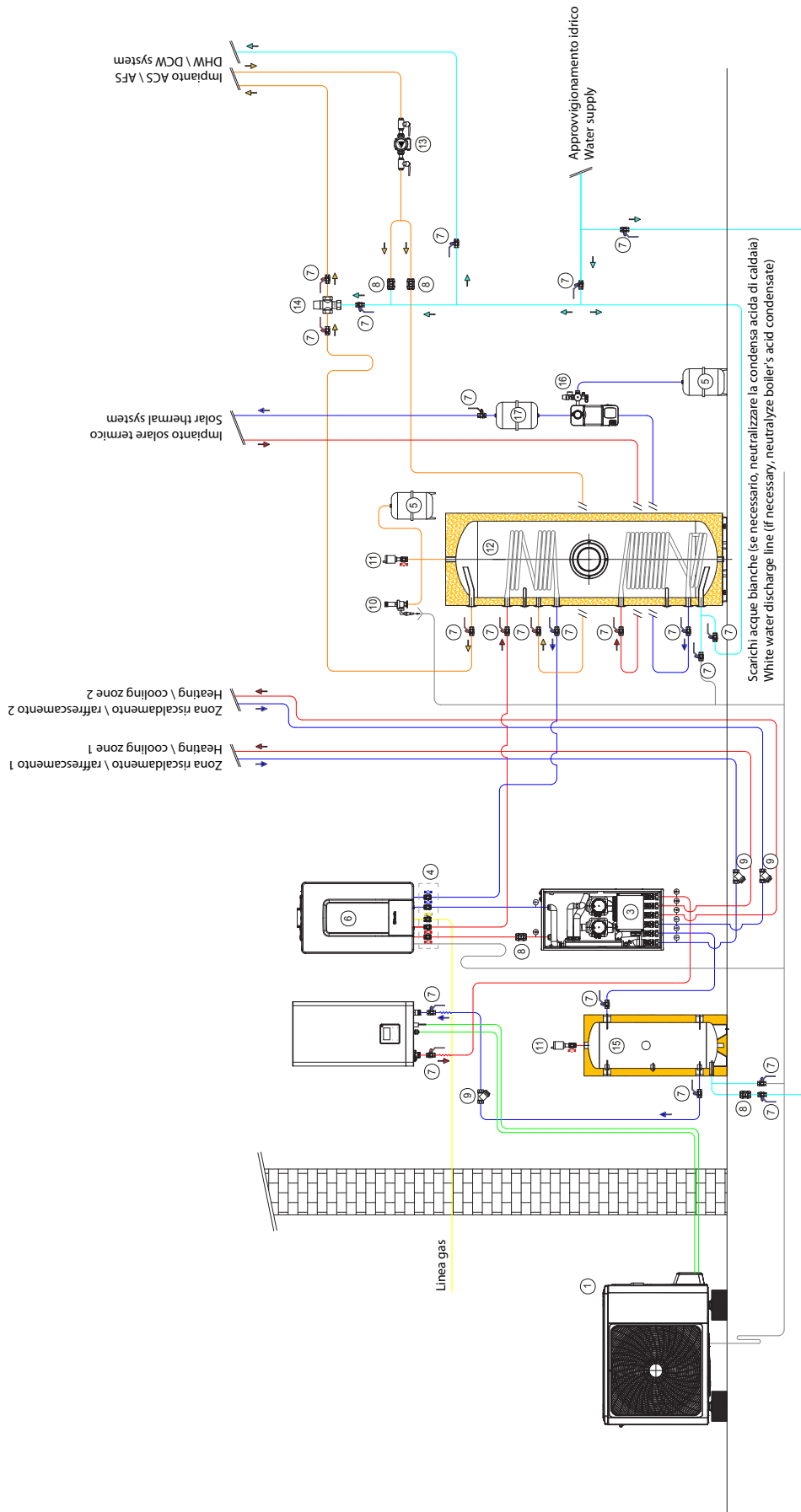

- (1) Heat pump outdoor unit
- (2) Heat pump indoor unit with circulator and reservoir
- (3) Hydraulic module with non-return valves
- (4) Under-boiler cock kit
- (5) Expansion reservoir
- (6) Boiler with circulator and reservoir
- (7) Shut-off valve
- (8) Non-return valve
- (9) Filter
- (10) Safety valve
- (11) Deaerator
- (12) DHW heater
- (13) DHW diverting valve
- (14) DHW mixer
- (15) Storage tank
- (16) Solar station with control unit
- (17) Pre-reservoir

HEAT PUMPS



HEAT PUMPS

82



## HYDRO UNIT P - HYDRONIC HEAT PUMPS



- Natural refrigerant R290 ensuring not only low Global Warming Potential (GWP100=0.02) and CO<sup>2</sup> emission
- Hydronic air-to-water heat pump
- Suitable for heating, cooling and domestic hot water production
- High leaving water heating temperature up to +75°C, ensure more usable hot water and helps to avoid the need for direct electric immersion to sterilize the water protecting from legionella.
- HP Keymark certified performance
- Blue Fin exchange coils with the special hydrophilic and anticorrosion treatment as standard
- Low noise
- Operating range -20 °C/+46 °C
- Variable speed circulating pump as standard
- Included WUI controller can manage heating/ cooling/ domestic hot water operation
- The controller WUI can manage up to 4 units in cascade system (1 primary & 3 secondary)
- Anti-freeze program protects the entire system especially the hydraulic parts from damage in very cold ambient air temperature.



### HEAT PUMP

CODE	MODEL	DIMENSIONS H x W x D (mm)	OUTPUT HEATING <sup>(1)</sup> /COOLING <sup>(2)</sup> (kW)	ENERGY EFFICIENCY CLASS (D → A+++)*	
				55°C	35°C
<b>SINGLE PHASE HEAT PUMPS</b>					
20198671	HYDRO UNIT P 004	927 x 946 x 400	3,95 / 4,00	A++	A+++
20198672	HYDRO UNIT P 006	927 x 946 x 400	5,80 / 6,15	A++	A+++
20198675	HYDRO UNIT P 008	927 x 946 x 400	7,60 / 8,00	A++	A+++
20198676	HYDRO UNIT P 010	927 x 946 x 400	9,60 / 8,90	A++	A+++
20198677	HYDRO UNIT P 012	1375 x 946 x 400	11,40 / 12,00	A++	A+++
20198679	HYDRO UNIT P 014	1375 x 946 x 400	13,80 / 14,50	A++	A+++
<b>THREE-PHASE HEAT PUMPS</b>					
20198681	HYDRO UNIT P 012T	1375 x 946 x 400	11,40 / 12,00	A++	A+++
20198682	HYDRO UNIT P 014T	1375 x 946 x 400	13,80 / 14,50	A++	A+++

(\*) HEATING: the range of energy efficiency class of this products category is between D and A+++

(1) Outdoor air d.b. + 7 °C / w.b. + 6 °C, water 30 °C - 35 °C.

(2) Outdoor air d.b. + 35 °C/w.b. + 24 °C, water 23 °C - 18 °C.

**ACCESSORIES**

CODE	DESCRIPTION
20204198	IDRA C-HP 150 MS storage tank <sup>(*)</sup>
20204200	IDRA C-HP 200 MS storage tank <sup>(*)</sup>
20204202	IDRA C-HP 300 MS storage tank <sup>(*)</sup>
20204204	IDRA C-HP 500 MS storage tank <sup>(*)</sup>
20010068	Temperature sensor for DHW tank (10kΩ) 5 m
20019654	External expansion vessel
4383270	1.5 kW single-phase electric heater kit <sup>(2) (7)</sup>
20182272	2.2 kW single-phase electric heater kit <sup>(1) (4) (6)</sup>
20020707	3,8 kW three-phase electric heater kit <sup>(2) (7)</sup>
20117745	IDRA HP 300 storage tank
20117746	IDRA HP 500 storage tank
20132795	1st direct/mixed zone control <sup>(1)(10)</sup>
20132796	Control of 2nd and 3rd direct/mixed zone <sup>(1)(9)(10)</sup>
20171999	50 litres inertial buffer tank
20142300	100 litres inertial buffer tank
20168920	1" DHW diverting valve with heater <sup>(1) (3) (6)</sup>
20175281	Y water filter 1"
20182292	Integrative electrical resistance 1PH-3PH 2-6 kW
20203246	Solar heat exchanger 1,2 m <sup>2</sup> for C-HP 500 storage tank <sup>(8)</sup>
20203248	Solar heat exchanger 0,8 m <sup>2</sup> for C-HP 150-300 storage tank <sup>(8)</sup>
20203742	1" & 1 1/4" DHW diverting valve without heater probe <sup>(2) (3) (5)</sup>
20205322	Hi, Comfort T300
20134478	Kit power supply for T300 <sup>(1)</sup>
20211852	Hi, Comfort T200 <sup>(1)</sup>
20209737	Service key for A2W R290
20210825	Primary/ secondary sensor (for cascade system) <sup>(2)</sup>
20210831	Anti-freeze relief valve 1"
20213763	Outside air temperature probe
20214128	Deareator 1 1/4" with relief valve 3 bar <sup>(7)</sup>
20217198	Vibration dampers kit for heat pumps
20221678	Drain pan heater (4-10kW)
20221679	Drain pan heater (12-14kW)

(\*) For the complete accessories please refer to the cylinder section.

(1) Only in combination with T300 remote control

(2) Accessory managed by the machine interface (WUI controller)

(3) Mandatory in case of domestic hot water cylinder installation

(4) Included electrical power box and activation relay

(5) The accessory must be used in combination with the temperature probe accessory 20010068.

(6) The kit includes the three-way diverting valve for DHW with heater probe

(7) Accessory included in the heat pump and mandatory for installation.

(8) The accessory must be ordered together with the base unit and is supplied not installed with finished product availability

(9) The first zone management kit (20132795) must always be present.

(10) Mandatory accessory when using REC10MHC or T300 for zone management



- Hydronic air-to-water heat pump
- HP Keymark certified performance.
- Modbus connectivity as standard
- Variable speed circulating pump as standard
- Source side exchanger with the special hydrophilic and anti-corrosion treatment as standard
- Suitable for heating, cooling and domestic hot water production
- Rotary compressor with DC-Inverter technology
- Operating range -25 °C/+43 °C
- Maximum heating temperature 65 °C
- Electronic expansion valve
- Expansion reservoir as standard
- Very low noise
- Ecological refrigerant R32
- Included remote control can manage completely heating/ cooling/ domestic hot water operation, as well as up to 6 units in cascade system (1 master & 5 slaves) even with different power inputs.
- Anti-freeze program protects the entire system especially the hydraulic parts from damage in very cold ambient air temperature.



## HEAT PUMP

CODE	MODEL	DIMENSIONS H x W x D (mm)	HEATING <sup>(1)</sup> /COOLING <sup>(2)</sup> OUTPUT (kW)	ENERGY EFFICIENCY CLASS	
				(D → A+++)*	
				55°C	35°C
<b>SINGLE-PHASE HEAT PUMPS</b>					
20203411	HYDRO UNIT M 004	718 x 1295 x 426	4,20 / 4,50	A <sup>++</sup>	A <sup>+++</sup>
20203413	HYDRO UNIT M 006	718 x 1295 x 426	6,35 / 6,50	A <sup>++</sup>	A <sup>+++</sup>
20203414	HYDRO UNIT M 008	865 x 1385 x 523	8,40 / 8,30	A <sup>++</sup>	A <sup>+++</sup>
20203416	HYDRO UNIT M 010	865 x 1385 x 523	10,00 / 9,90	A <sup>++</sup>	A <sup>+++</sup>
20203656	HYDRO UNIT M 012	865 x 1385 x 523	12,10 / 12,00	A <sup>++</sup>	A <sup>+++</sup>
20203659	HYDRO UNIT M 014	865 x 1385 x 523	14,50 / 13,50	A <sup>++</sup>	A <sup>+++</sup>
20203660	HYDRO UNIT M 016	865 x 1385 x 523	15,90 / 14,20	A <sup>++</sup>	A <sup>+++</sup>
<b>THREE-PHASE HEAT PUMPS</b>					
20203672	HYDRO UNIT M 012T	865 x 1385 x 523	12,10 / 12,00	A <sup>++</sup>	A <sup>+++</sup>
20203674	HYDRO UNIT M 014T	865 x 1385 x 523	14,50 / 13,50	A <sup>++</sup>	A <sup>+++</sup>
20203678	HYDRO UNIT M 016T	865 x 1385 x 523	15,90 / 14,20	A <sup>++</sup>	A <sup>+++</sup>

(\*) HEATING: the range of energy efficiency class of this products category is between D and A+++

(1) Outdoor air d.b. + 7 °C / w.b. + 6 °C, water 30 °C - 35 °C.

(2) Outdoor air d.b. + 35 °C/w.b. + 24 °C, water 23 °C - 18 °C.

Models suitable for stand-alone installation and for full electric systems in combination with REC10MHC control, for hybrid systems (see the dedicated section).

**ACCESSORIES**

CODE	DESCRIPTION
20117745	IDRA HP 300 storage tank <sup>(1)</sup>
20117746	IDRA HP 500 storage tank <sup>(1)</sup>
20204198	IDRA C-HP 150 MS storage tank <sup>(1)</sup>
20204200	IDRA C-HP 200 MS storage tank <sup>(1)</sup>
20204202	IDRA C-HP 300 MS storage tank <sup>(1)</sup>
20204204	IDRA C-HP 500 MS storage tank <sup>(1)</sup>
20171999	50 litre inertial buffer tank <sup>(9)</sup>
20203248	Solar heat exchanger 0,8m <sup>2</sup> for C-HP 150-300
20203246	Solar heat exchanger 1,2m <sup>2</sup> for C-HP 500
20203742	1 1/4" DHW diverting valve without temperature probe <sup>(1) (4) (5)</sup>
20175281	1" Y water filter <sup>(7)</sup>
20207834	REC10MHC remote control
20205322	Hi, Comfort T300
20134478	Kit power supply <sup>(10)</sup>
4383270	Single-phase resistance kit 1,5 kW 1 "1/2 for IDRA HP 300 storage tank <sup>(2)</sup>
20020707	Three-phase resistance kit 3,8 kW 1 "1/2 for IDRA HP 500 storage tank <sup>(2)</sup>
20182272	Single-phase electric heating element for DHW heater 2,2 kW <sup>(3) (6) (8)</sup>
20182292	1PH-3PH 2-6 kW supplemental electric heating element
20194933	Temperature probe for balance tank or zone 2 flow temperature or solar temperature

(\*) For the complete accessories please refer to the cylinder section.

(1) Mandatory in case of domestic hot water installation.

(2) The accessory must be ordered together with the base unit and is supplied not installed with finished product availability.

(3) Only in combination with REC10MHC remote control.

(4) Accessory managed by the machine interface.

(5) It must be used in combination with the temperature probe included in the heat pump or with accessory 20194933.

(6) The kit includes the three-way diverting valve for DHW with storage tank probe.

(7) The corresponding filter is supplied with the product. If necessary, it must be used only for HYDRO UNIT M 004 and 006 models.

(8) Includes electrical power box and activation relay.

(9) The buffer tank cannot be installed horizontally under the heat pump

(10) Only in combination with REC10MHC or T300 remote control.



Heat pumps

## HYDRO UNIT M - HYDRONIC HEAT PUMPS



- Hydronic air to water heat pump monobloc
- HP Keymark certified performance.
- Modbus connection as standard
- Variable speed circulating pump as standard
- Source side exchanger with the special hydrophilic and anti-corrosion treatment as standard
- Suitable for heating, cooling and domestic hot water production
- Rotary compressor with DC-Inverter technology
- Operating range -25°C/+43°C
- Maximum heating temperature 60°C
- Electronic expansion valve
- Expansion vessel as standard
- Silent operation
- Ecological refrigerant R32
- Included remote control included can manage completely heating/ cooling/ domestic hot water operation, as well as up to 6 units in cascade system (1 master & 5 slaves) even with different power inputs.
- Anti-freeze program protects the entire system especially the hydraulic parts from damage in very cold ambient air temperature



### HEAT PUMP

CODE	MODEL	DIMENSIONS H x W x D (mm)	HEATING <sup>(1)</sup> /COOLING <sup>(2)</sup> OUTPUT (kW)	ENERGY EFFICIENCY CLASS	
				(D → A+++)*	
				55°C	35°C
<b>THREE-PHASE HEAT PUMPS</b>					
20194173	HYDRO UNIT M 018T	1558 x 1129 x 528	18,00/ 18,50	A <sup>++</sup>	A <sup>+++</sup>
20194174	HYDRO UNIT M 022T	1558 x 1129 x 528	22,00/ 23,00	A <sup>++</sup>	A <sup>+++</sup>
20194175	HYDRO UNIT M 026T	1558 x 1129 x 528	26,00/ 27,00	A <sup>+</sup>	A <sup>+++</sup>
20194176	HYDRO UNIT M 030T	1558 x 1129 x 528	30,10/ 31,00	A <sup>+</sup>	A <sup>++</sup>

(\*) HEATING: the range of energy efficiency class of this products category is between D and A+++

(1) Outdoor air d.b. + 7 °C / w.b. + 6 °C, water 30 °C - 35 °C.

(2) Outdoor air d.b. + 35 °C/w.b. + 24 °C, water 23 °C - 18 °C.).

**ACCESSORIES**

CODE	DESCRIPTION
20056180	STOR H 200 inertial buffer tank
20117746	Heater IDRA HP 500 for heat pump
20204206	IDRA C-HP 800 MS
20204208	IDRA C-HP 1000 MS
4383505	Solar heat exchanger for IDRA HP 500 <sup>(2)</sup>
20203245	Solar heat exchanger 1,9 m <sup>2</sup> for IDRA C-HP 800-100 storage tank
4383270	Single-phase electrical resistance 1,5 kW, 1" 1/2 <sup>(1) (2)</sup>
4383271	Single-phase electrical resistance kit 2,2 kW 1" 1/2 <sup>(1) (2)</sup>
4383272	Single-phase electrical resistance kit 3,0 kW 1" 1/2 <sup>(1) (2)</sup>
20020707	Three-phase electrical resistance kit 3,8 kW, 1" 1/2 <sup>(1) (2)</sup>
20182292	1PH-3PH 2-6 kW supplemental electric heating element
20142300	STOR H 100 - 100-litre technical hot/cold tank kit
20175145	Support bracket kit for heat pump installed on STOR H 100
20171891	Heat pump vibration damper kit
20203742	1" & 1 1/4" DHW diverting valve without temperature probe <sup>(3)</sup>
20194933	Temperature probe for balance tank or zone 2 flow temperature or solar temperature

(1) For stand-alone installation.

(2) The accessory must be ordered together with the base unit and is supplied not installed with finished product availability.

(3) The accessory must be used in combination with the temperature probe included in the heat pump, or accessory 20194933.



## EXCLUSIVE AGILE - WALL HUNG SPLIT HEAT PUMP



- Split heat pump with wall-hung indoor unit for heating, cooling and DHW production.
- Wide range of sizes available, from 4 up to 16 kW.
- High efficiency up to A+++ class.
- Intelligent management of auxiliary energy sources: integrative heating element, boiler, solar thermal unit.
- Twin Rotary DC inverter compressor and electronic expansion valve.
- Fan with brushless motor and finned pack coil optimised for operation at outdoor air temperature of -25°C.
- Compact and extremely silent external unit with R32 gas.
- Indoor unit with and without back up heater.
- Easy to use control panel with backlit display and multilingual menu.
- Compact indoor unit: only 270 mm of depth.



### WALL HUNG SPLIT HEAT PUMPS

CODE	DESCRIPTION	DIMENSIONS		HEATING				COOLING				ENERGY EFFICIENCY CLASS		
		Outdoor unit H x W x D (mm)	Floor system <sup>(1)</sup>		Fan coils <sup>(2)</sup>		Floor system <sup>(3)</sup>		Fan coils <sup>(4)</sup>		(D → A+++)*			
			Heating capacity (kW)	COP	Heating capacity (kW)	COP	Cooling capacity (kW)	EER	Cooling capacity (kW)	EER	<sup>+</sup> 35°C <sup>(5)</sup>	<sup>+</sup> 55°C <sup>(6)</sup>		
<b>WITHOUT ON BOARD BACK UP HEATER</b>														
20205784	SET EXCLUSIVE AGILE 4 KW M	712 x 1008 x 426	4,25	5,20	4,35	3,80	4,50	5,55	4,70	3,45	A+++	A++		
20205786	SET EXCLUSIVE AGILE 6 KW M	712 x 1008 x 426	6,20	5,00	6,35	3,75	6,55	4,90	7,00	3,00	A+++	A++		
20205788	SET EXCLUSIVE AGILE 8 KW M	865 x 1118 x 523	8,30	5,20	8,20	3,95	8,40	5,05	7,40	3,38	A+++	A++		
20205791	SET EXCLUSIVE AGILE 10 KW M	865 x 1118 x 523	10,00	5,00	10,00	3,80	10,00	4,80	8,20	3,30	A+++	A++		
20205793	SET EXCLUSIVE AGILE 12 KW M	865 x 1118 x 523	12,10	4,95	12,30	3,80	12,00	4,00	11,60	2,75	A+++	A++		
20205800	SET EXCLUSIVE AGILE 14 KW M	865 x 1118 x 523	14,50	4,70	14,20	3,65	13,50	3,61	12,70	2,55	A+++	A++		
20205802	SET EXCLUSIVE AGILE 16 KW M	865 x 1118 x 523	16,00	4,50	16,00	3,60	14,20	3,61	14,00	2,45	A+++	A++		
20205804	SET EXCLUSIVE AGILE 12 KW T	865 x 1118 x 523	12,10	4,95	12,30	3,80	12,00	4,00	11,60	2,75	A+++	A++		
20205806	SET EXCLUSIVE AGILE 14 KW T	865 x 1118 x 523	14,50	4,70	14,20	3,65	13,50	3,61	12,70	2,55	A+++	A++		
20205809	SET EXCLUSIVE AGILE 16 KW T	865 x 1118 x 523	16,00	4,50	16,00	3,60	14,20	3,61	14,00	2,45	A+++	A++		

# EXCLUSIVE AGILE - WALL HUNG SPLIT HEAT PUMP

CODE	DESCRIPTION	DIMENSIONS		HEATING				COOLING				ENERGY EFFICIENCY CLASS	
		Outdoor unit		Floor system <sup>(1)</sup>		Fan coils <sup>(2)</sup>		Floor system <sup>(3)</sup>		Fan coils <sup>(4)</sup>		(D → A+++)*	
		H x W x D (mm)		Heating capacity (kW)	COP	Heating capacity (kW)	COP	Cooling capacity (kW)	EER	Cooling capacity (kW)	EER		

**WITH ON BOARD BACK UP HEATER**

20205785	SET EXCLUSIVE AGILE 4 KW M BH	712 x 1008 x 426	4,25	5,20	4,35	3,80	4,50	5,55	4,70	3,45	A+++	A++
20205787	SET EXCLUSIVE AGILE 6 KW M BH	712 x 1008 x 426	6,20	5,00	6,35	3,75	6,55	4,90	7,00	3,00	A+++	A++
20205789	SET EXCLUSIVE AGILE 8 KW M BH	865 x 1118 x 523	8,30	5,20	8,20	3,95	8,40	5,05	7,40	3,38	A+++	A++
20205792	SET EXCLUSIVE AGILE 10 KW M BH	865 x 1118 x 523	10,00	5,00	10,00	3,80	10,00	4,80	8,20	3,30	A+++	A++
20205794	SET EXCLUSIVE AGILE 12 KW M BH	865 x 1118 x 523	12,10	4,95	12,30	3,80	12,00	4,00	11,60	2,75	A+++	A++
20205801	SET EXCLUSIVE AGILE 14 KW M BH	865 x 1118 x 523	14,50	4,70	14,20	3,65	13,50	3,61	12,70	2,55	A+++	A++
20205803	SET EXCLUSIVE AGILE 16 KW M BH	865 x 1118 x 523	16,00	4,50	16,00	3,60	14,20	3,61	14,00	2,45	A+++	A++
20205805	SET EXCLUSIVE AGILE 12 KW T BH	865 x 1118 x 523	12,10	4,95	12,30	3,80	12,00	4,00	11,60	2,75	A+++	A++
20205807	SET EXCLUSIVE AGILE 14 KW T BH	865 x 1118 x 523	14,50	4,70	14,20	3,65	13,50	3,61	12,70	2,55	A+++	A++
20205810	SET EXCLUSIVE AGILE 16 KW T BH	865 x 1118 x 523	16,00	4,50	16,00	3,60	14,20	3,61	14,00	2,45	A+++	A++

(\*) HEATING: the range of energy efficiency class of this products category is between D and A+++

The performance is in accordance with standard EN 14511-3:2013 and refers to the following conditions:

(1) External air temperature 7°C DB, 6°C WB; water inlet/outlet 30/35°C.

(2) External air temperature 7°C DB, 6°C WB; water inlet/outlet 40/45°C.

(3) External air temperature 35°C; water inlet/outlet 23/18°C.

(4) External air temperature 35°C; water inlet/outlet 12/7°C.

(5) Seasonal energy efficiency class for average climate zone for 35 °C delivery temperature. Values comply with Regulation 811/2013.

(6) Seasonal energy efficiency class for average climate zone for 55 °C delivery temperature. Values comply with Regulation 811/2013.

Note: The sets marked with "BH" in the description are those in which the internal unit has an integrated resistance. In single-phase sets, the power of the integrated resistance, where present, is 3 kW, while in three-phase sets it is 9 kW.

## EXCLUSIVE AGILE - WALL HUNG SPLIT HEAT PUMP

### SET CODES MATCHING TABLE

DESCRIPTION	SET CODE	INTERNAL UNIT CODE	EXTERNAL UNIT CODE
<b>WITHOUT ON BOARD BACK UP HEATER</b>			
SET EXCLUSIVE AGILE 4 kW M	20205784	20199007	20198986
SET EXCLUSIVE AGILE 6 kW M	20205786	20199007	20198987
SET EXCLUSIVE AGILE 8 kW M	20205788	20199009	20198988
SET EXCLUSIVE AGILE 10 kW M	20205791	20199009	20198990
SET EXCLUSIVE AGILE 12 kW M	20205793	20199010	20198991
SET EXCLUSIVE AGILE 14 kW M	20205800	20199010	20198992
SET EXCLUSIVE AGILE 16 kW M	20205802	20199010	20198993
SET EXCLUSIVE AGILE 12 kW T	20205804	20199010	20198994
SET EXCLUSIVE AGILE 14 kW T	20205806	20199010	20198995
SET EXCLUSIVE AGILE 16 kW T	20205809	20199010	20198996
<b>WITH ON BOARD BACK UP HEATER</b>			
SET EXCLUSIVE AGILE 4 kW M BH	20205785	20198980	20198986
SET EXCLUSIVE AGILE 6 kW M BH	20205787	20198980	20198987
SET EXCLUSIVE AGILE 8 kW M BH	20205789	20198981	20198988
SET EXCLUSIVE AGILE 10 kW M BH	20205792	20198981	20198990
SET EXCLUSIVE AGILE 12 kW M BH	20205794	20198982	20198991
SET EXCLUSIVE AGILE 14 kW M BH	20205801	20198982	20198992
SET EXCLUSIVE AGILE 16 kW M BH	20205803	20198982	20198993
SET EXCLUSIVE AGILE 12 kW T BH	20205805	20198985	20198994
SET EXCLUSIVE AGILE 14 kW T BH	20205807	20198985	20198995
SET EXCLUSIVE AGILE 16 kW T BH	20205810	20198985	20198996

### ACCESSORIES

CODE	DESCRIPTION
20117881	IDRA DS 300 storage tank <sup>(*)</sup>
20117882	IDRA DS 500 storage tank <sup>(*)</sup>
20117745	IDRA HP 300 storage tank <sup>(*)</sup>
20117746	IDRA HP 500 storage tank <sup>(*)</sup>
20204198	IDRA C-HP 150 MS storage tank <sup>(*)</sup>
20204200	IDRA C-HP 200 MS storage tank <sup>(*)</sup>
20204202	IDRA C-HP 300 MS storage tank <sup>(*)</sup>
20204204	IDRA C-HP 500 MS storage tank <sup>(*)</sup>
20171999	50-litre inertial buffer tank
20203742	1" & 1 1/4" DHW diverting valve without temperature probe

# EXCLUSIVE AGILE - WALL HUNG SPLIT HEAT PUMP

CODE	DESCRIPTION
20175281	1" Y water filter <sup>(7)</sup>
20207834	REC10MHC remote control
20205322	Hi, Comfort T300
20134478	Kit power supply <sup>(10)</sup>
4383270	Single-phase electrical resistance 1,5 kW 1" 1/2 <sup>(2)(1)</sup>
2002707	Three-phase electrical resistance kit 3,8 kW 1" 1/2 <sup>(2) (1)</sup>
20182272	Single-phase electric heating element for DHW heater 2,2 kW <sup>(3) (6) (8)</sup>
20182292	1PH-3PH 2-6 kW supplemental electric heating element <sup>(9)</sup>
20194933	Temperature probe for balance tank or zone 2 flow temperature or solar temperature
20132795	1st direct/mixed zone control <sup>(10)(11)</sup>
20132796	Control of 2nd and 3rd direct/mixed zone <sup>(10)(11)</sup>

(\*) For the complete accessories please refer to the cylinder section.

(1) Mandatory in case of domestic hot water installation.

(2) The accessory must be ordered together with the base unit and is supplied not installed with finished product availability.

(3) Only in combination with REC10MHC remote control.

(4) Accessory managed by the machine interface.

(5) It must be used in combination with the temperature probe included in the heat pump or with accessory.

(6) The kit includes the three-way diverting valve for DHW with storage tank probe.

(7) The corresponding filter is supplied with the product. If necessary, it must be used only for HYDRO UNIT M 004 and 006 models.

(8) Includes electrical power box and activation relay.

(9) The buffer tank cannot be installed horizontally under the heat pump.

(10) Only in combination with REC10MHC or T300 remote control.

(11) The first zone management kit (20132795) must always be present.

## SUGGESTED CYLINDER AND HEAT PUMP MATCHING

CYLINDER		HEAT PUMP EXCLUSIVE AGILE									
CODE	MODEL	4 M	6 M	8 M	10 M	12 M	14 M	16 M	12 T	14 T	16 T
		20205784	20205786	20205788	20205791	20205793	20205800	20205802	20205804	20205806	20205809
20204198	IDRA C-HP 150 MS	•	•								
20204200	IDRA C-HP 200 MS	•	•	•							
20204202	IDRA C-HP 300 MS	•	•	•	•	•			•		
20204204	IDRA C-HP 500 MS			•	•	•	•	•	•	•	•
20204206	IDRA C-HP 800 MS					•	•	•	•	•	•
20204208	IDRA C-HP 1000 MS							•			•

To select the correct size of the cylinder, please refer to the data in the technical sheet of the product and to the specific requirement of the system.

Note: Cylinders are compatible as in the above table also with split heat pump sets with back up heater on board.



## Heat Pumps

## TOWER GREEN M - FLOOR STANDING SPLIT HEAT PUMP



- A floor-standing split heat pump system for heating, cooling and domestic water production.
- The system consists of an outdoor unit with R32 refrigerant connected through refrigerant pipes to the indoor floor-standing unit.
- The outdoor unit, compact and quiet, includes a Twin Rotary DC inverter compressor, electronic expansion valve, fans with brushless motor and finned pack coil optimized for heat pump operation even with outdoor air temperature of -25°C.
- The main components of the hydronic system are located in the indoor unit, including a cylinder of 190l or 240l with high-surface for domestic hot water (DHW) production.
- Hydraulic, electrical and refrigeration connections from the top
- Front access to all components for easy installation and service
- Equipped with 3kW or 2/4/6kW or 3/6/9 kW back-up heater, depending on the models, offering stable performance
- Simple and intuitive control panel with large display and available in multi-languages



## FLOOR STANDING SPLIT HEAT PUMP

CODE	DESCRIPTION	DIMENSIONS H x W x D (mm)	HEATING				COOLING				ENERGY EFFICIENCY CLASS	
			Floor system <sup>(1)</sup>		Fan coils <sup>(2)</sup>		Floor system <sup>(3)</sup>		Fan coils <sup>(4)</sup>		(D→A <sup>+++</sup> )*	(F→A <sup>+</sup> )*
			Heating capacity (kW)	COP	Heating capacity (kW)	COP	Cooling capacity (kW)	EER	Cooling capacity (kW)	EER	III <sup>°</sup> 35°C <sup>(5)</sup>	III <sup>°</sup> 55°C <sup>(6)</sup>
<b>VERSION WITH 190L CYLINDER</b>												
20220967	SET TOWER GREEN M 4M DHW M31	712 x 1008 x 426 (ODU) / 1683 x 600 x 600 (IDU)	4,25	5,20	4,35	3,80	4,50	5,55	4,70	3,45	A <sup>+++</sup>	A <sup>+</sup>
20220969	SET TOWER GREEN M 6M DHW M31	712 x 1008 x 426 (ODU) / 1683 x 600 x 600 (IDU)	6,20	5,00	6,35	3,75	6,55	4,90	7,00	3,00	A <sup>+++</sup>	A <sup>+</sup>
20220970	SET TOWER GREEN M 8M DHW M31	865 x 1118 x 523 (ODU) / 1683 x 600 x 600 (IDU)	8,30	5,20	8,20	3,95	8,40	5,05	7,40	3,38	A <sup>+++</sup>	A <sup>+</sup>
20220971	SET TOWER GREEN M 10M DHW M31	865 x 1118 x 523 (ODU) / 1683 x 600 x 600 (IDU)	10,00	5,00	10,00	3,80	10,00	4,80	8,20	3,30	A <sup>+++</sup>	A <sup>+</sup>
20220972	SET TOWER GREEN M 4M DHW M61	865 x 1118 x 523 (ODU) / 1683 x 600 x 600 (IDU)	4,25	5,20	4,35	3,80	4,50	5,55	4,70	3,45	A <sup>+++</sup>	A <sup>+</sup>
20220973	SET TOWER GREEN M 6M DHW M61	865 x 1118 x 523 (ODU) / 1683 x 600 x 600 (IDU)	6,20	5,00	6,35	3,75	6,55	4,90	7,00	3,00	A <sup>+++</sup>	A <sup>+</sup>
20220974	SET TOWER GREEN M 8M DHW M61	865 x 1118 x 523 (ODU) / 1683 x 600 x 600 (IDU)	8,30	5,20	8,20	3,95	8,40	5,05	7,40	3,38	A <sup>+++</sup>	A <sup>+</sup>
20220975	SET TOWER GREEN M 10M DHW M61	865 x 1118 x 523 (ODU) / 1683 x 600 x 600 (IDU)	10,00	5,00	10,00	3,80	10,00	4,80	8,20	3,30	A <sup>+++</sup>	A <sup>+</sup>
<b>VERSION WITH 240L CYLINDER</b>												
20221041	SET TOWER GREEN M 4M DHW L31	712 x 1008 x 426 (ODU) / 1943 x 600 x 600 (IDU)	4,25	5,20	4,35	3,80	4,50	5,55	4,70	3,45	A <sup>+++</sup>	A <sup>+</sup>
20221043	SET TOWER GREEN M 6M DHW L31	712 x 1008 x 426 (ODU) / 1943 x 600 x 600 (IDU)	6,20	5,00	6,35	3,75	6,55	4,90	7,00	3,00	A <sup>+++</sup>	A <sup>+</sup>

# TOWER GREEN M - FLOOR STANDING SPLIT HEAT PUMP

CODE	DESCRIPTION	DIMENSIONS H x W x D (mm)	HEATING				COOLING				ENERGY EFFICIENCY CLASS	
			Floor system <sup>(1)</sup>		Fan coils <sup>(2)</sup>		Floor system <sup>(3)</sup>		Fan coils <sup>(4)</sup>		(D→A+++)*	(F→A+)*
			Heating capacity (kW)	COP	Heating capacity (kW)	COP	Cooling capacity (kW)	EER	Cooling capacity (kW)	EER	35°C <sup>(5)</sup>	55°C <sup>(6)</sup>
20221044	SET TOWER GREEN M 8M DHW L31	865 x 1118 x 523 (ODU) / 1943 x 600 x 600 (IDU)	8,30	5,20	8,20	3,95	8,40	5,05	7,40	3,38	A+++	A+
20221045	SET TOWER GREEN M 10M DHW L31	865 x 1118 x 523 (ODU) / 1943 x 600 x 600 (IDU)	10,00	5,00	10,00	3,80	10,00	4,80	8,20	3,30	A+++	A+
20221046	SET TOWER GREEN M 4M DHW L61	865 x 1118 x 523 (ODU) / 1943 x 600 x 600 (IDU)	4,25	5,20	4,35	3,80	4,50	5,55	4,70	3,45	A+++	A+
20221047	SET TOWER GREEN M 6M DHW L61	865 x 1118 x 523 (ODU) / 1943 x 600 x 600 (IDU)	6,20	5,00	6,35	3,75	6,55	4,90	7,00	3,00	A+++	A+
20221048	SET TOWER GREEN M 8M DHW L61	865 x 1118 x 523 (ODU) / 1943 x 600 x 600 (IDU)	8,30	5,20	8,20	3,95	8,40	5,05	7,40	3,38	A+++	A+
20221050	SET TOWER GREEN M 10M DHW L61	865 x 1118 x 523 (ODU) / 1943 x 600 x 600 (IDU)	10,00	5,00	10,00	3,80	10,00	4,80	8,20	3,30	A+++	A+
20221052	SET TOWER GREEN M 12M DHW L61	865 x 1118 x 523 (ODU) / 1943 x 600 x 600 (IDU)	12,10	4,95	12,30	3,80	12,00	4,00	11,60	2,75	A+++	A+
20221054	SET TOWER GREEN M 14M DHW L61 <sup>(7)</sup>	865 x 1118 x 523 (ODU) / 1943 x 600 x 600 (IDU)	14,50	4,70	14,20	3,65	13,50	3,61	12,70	2,55	A+++	A+
20221056	SET TOWER GREEN M 16M DHW L61 <sup>(7)</sup>	865 x 1118 x 523 (ODU) / 1943 x 600 x 600 (IDU)	16,00	4,50	16,00	3,60	14,20	3,61	14,00	2,45	A+++	A+
20221062	SET TOWER GREEN M 12T DHW L93	865 x 1118 x 523 (ODU) / 1943 x 600 x 600 (IDU)	12,10	4,95	12,30	3,80	12,00	4,00	11,60	2,75	A+++	A+
20221066	SET TOWER GREEN M 14T DHW L93 <sup>(7)</sup>	865 x 1118 x 523 (ODU) / 1943 x 600 x 600 (IDU)	14,50	4,70	14,20	3,65	13,50	3,61	12,70	2,55	A+++	A+
20221067	SET TOWER GREEN M 16T DHW L93 <sup>(7)</sup>	865 x 1118 x 523 (ODU) / 1943 x 600 x 600 (IDU)	16,00	4,50	16,00	3,60	14,20	3,61	14,00	2,45	A+++	A+

The performance is in accordance with standard EN 14511

(1) Heating: delivery water temperature 45 °C with gradient 5K; outdoor air temperature 7 °C Tb.s and 6 °C Tb.u.

(2) Heating: delivery water temperature 35 °C with thermal gradient 5K; outdoor air temperature 7 °C Tb.s and 6 °C Tb.u.

(3) Cooling: delivery water temperature 7 °C with water thermal gradient 5 °C; inlet air temp. 35 °C.

(4) Cooling: delivery water temperature 18 °C with water thermal gradient 5 °C; inlet air temp. 35 °C.

(5) Value referred to the average climate profile for a flow temperature of 35°C, in compliant with Regulation 811/2013.

(6) Value referred to the average climate for tank temperature setpoint of 53°C, in compliant with the EN 16147 standard

(7) For 14kW & 16kW, it's necessary to have primary and secondary circuit on water side

(\*) HEATING: the energy class of the products ranges from D up to A+++ / DHW: the energy class of the products ranges from F up to A+

## TOWER GREEN M - FLOOR STANDING SPLIT HEAT PUMP

### SET CODES MATCHING TABLE

DESCRIPTION	SET CODE	INTERNAL UNIT CODE	EXTERNAL UNIT CODE
<b>VERSION WITH 190L CYLINDER</b>			
SET TOWER GREEN M 4M DHW M31	20220967	20220693 <sup>(1)</sup>	20198986
SET TOWER GREEN M 6M DHW M31	20220969	20220693 <sup>(1)</sup>	20198987
SET TOWER GREEN M 8M DHW M31	20220970	20220693 <sup>(1)</sup>	20198988
SET TOWER GREEN M 10M DHW M31	20220971	20220693 <sup>(1)</sup>	20198990
SET TOWER GREEN M 4M DHW M61	20220972	20220758 <sup>(2)</sup>	20198986
SET TOWER GREEN M 6M DHW M61	20220973	20220758 <sup>(2)</sup>	20198987
SET TOWER GREEN M 8M DHW M61	20220974	20220758 <sup>(2)</sup>	20198988
SET TOWER GREEN M 10M DHW M61	20220975	20220758 <sup>(2)</sup>	20198990
<b>VERSION WITH 240L CYLINDER</b>			
SET TOWER GREEN M 4M DHW L31	20221041	20220768 <sup>(1)</sup>	20198986
SET TOWER GREEN M 6M DHW L31	20221043	20220768 <sup>(1)</sup>	20198987
SET TOWER GREEN M 8M DHW L31	20221044	20220768 <sup>(1)</sup>	20198988
SET TOWER GREEN M 10M DHW L31	20221045	20220768 <sup>(1)</sup>	20198990
SET TOWER GREEN M 4M DHW L61	20221046	20220773 <sup>(2)</sup>	20198986
SET TOWER GREEN M 6M DHW L61	20221047	20220773 <sup>(2)</sup>	20198987
SET TOWER GREEN M 8M DHW L61	20221048	20220773 <sup>(2)</sup>	20198988
SET TOWER GREEN M 10M DHW L61	20221050	20220773 <sup>(2)</sup>	20198990
SET TOWER GREEN M 12M DHW L61	20221052	20220777 <sup>(2)</sup>	20198991
SET TOWER GREEN M 14M DHW L61	20221054	20220777 <sup>(2)</sup>	20198992
SET TOWER GREEN M 16M DHW L61	20221056	20220777 <sup>(2)</sup>	20198993
SET TOWER GREEN M 12T DHW L93	20221062	20220781 <sup>(3)</sup>	20198994
SET TOWER GREEN M 14T DHW L93	20221066	20220781 <sup>(3)</sup>	20198995
SET TOWER GREEN M 16T DHW L93	20221067	20220781 <sup>(3)</sup>	20198996

(1) Including back-up heater of 3kW/ 1-phase

(2) Including back-up heater of 4kW/ 1-phase as default, and configurable on-site to either 2kW/ 1-phase or 6kW/ 1-phase.

(3) Including back-up heater of 9kW/ 3-phase. and configurable on-site to either 3kW/ 3-phase or 6kW/ 3-phase.

## TOWER GREEN M - FLOOR STANDING SPLIT HEAT PUMP

### ACCESSORIES

CODE	DESCRIPTION
20171999	50 litre inertial buffer tank
20222905	Hi, Comfort T300-I <sup>(1)</sup>
20211852	Hi, Comfort T200 <sup>(2)</sup>
20194933	Temperature probe for buffer or dhw cylinder
20223850	8 Litre DHW expansion vessel kit <sup>(3)</sup>
20182807	Adjustable bypass valve
20020778	¾" thermostatic mixing valve kit
20065681	25 DIR Module
20065683	25 MIX Module
20065684	32 DIR Module
20065685	32 MIX Module

(1) Included power supply kit

(2) The accessory must be used in combination with T300

(3) The kit is installed on the back of the indoor unit and includes 10-bar safety valve

WALL HUNG BOILERS



CONDENSING WALL-HUNG BOILERS	103
STANDARD-EFFICIENCY WALL-HUNG BOILERS	127
SYSTEM COMPLEMENTARY ITEMS	144
FLUE OPTION SYSTEMS	164

Condensing wall-hung

# PRODUCT MATRIX OF BERETTA CONDENSING WALL-HUNG BOILERS

PRODUCT	PRODUCT ENERGY EFFICIENCY CLASS		SYSTEM ENERGY CLASS	HEATING-ONLY MODELS (kW)	COMBI MODELS (kW)	DHW TANK TYPE	INSTALLATION MODE
Exclusive Evo X	 	A	A	A+ with optional kit <sup>(6)</sup> 25 35	25 30 35	Instantaneous	Indoor Outdoor Built-in
Mynute Evo X	 	A	A	A+ with optional kit <sup>(6)</sup> 20 30	25 30 35	Instantaneous	Indoor Outdoor Built-in
Mynute Boiler Evo X		A	A	- -	25 35	Instantaneous	
Ciao X		A	A	A+ with optional kit <sup>(4)</sup> 15 25 -	- 25 30	Instantaneous	Indoor Outdoor Built-in <sup>(3)</sup>
BLR		A	A	-	- 25 30	Instantaneous	Indoor Outdoor Built-in <sup>(3)</sup>
Meteo X	 	A	A	A+ with optional kit <sup>(4)</sup> -	25 30	Instantaneous	External boiler

(1) Need 1 pc. of the Hi Control, Comfort T100 Wi-Fi (cod. 20193354) or 1 pc. of the Hi control, Comfort T100 (cod. 20193352) with 1 pc. of the external temperature probe kit with connector (cod. 1220559)

(2) Required 1 pc. of the Command Hi, Comfort T100 (cod. 20193352)

(3) Combined boilers only

(4) Need 3 pcs. of the Hi Control, Comfort T100 (cod. 20193352) with 1 pc. of the external temperature probe kit with connector (COD. 1220559)

(5) Maximum development in length of the intubation (maximum value with Beretta smoke Ø50 class H1 or Ø60 class H1). The length is in addition to a split smoke and air line at the boiler outlet. Smoke: 4.5 m Ø80 + 1 curve Ø80 at 90°; Air: 4.5 m Ø80 + 1 curve Ø80 at 90°

(6) The system achieves class A+ in combination with T300 or T100.

# PRODUCT MATRIX OF BERETTA CONDENSING WALL-HUNG BOILERS

DIMENSIONS H x W x D (mm)	REMOTE CONTROL	Internet management from smartphones and tablets	MODULATION RANGE	Expansion vessel (l)	CIRCULATOR HEAD	FLUE SYSTEM Ø50 <sup>(5)</sup> (m)	FLUE SYSTEM Ø60 <sup>(5)</sup> (m)
740 x 420 x 275	Hi, Comfort T100 <sup>(2)</sup> and T300 optional	Hi, Comfort T100 <sup>(2)</sup> e T300 optional	up to 1:13	9	modulating up to 7 m	28 11 11	74 34 34
740 x 420 x 275	Hi, Comfort T100 <sup>(2)</sup> and T300 optional	Hi, Comfort T100 <sup>(2)</sup> e T300 optional	up to 1:10	9	modulating up to 6 m	28 28 11 11	74 74 34 34
740 x 420 x 275			up to 1:10				
700 x 400 x 275 700 x 400 x 275 700 x 400 x 275	Hi, Comfort T100 <sup>(2)</sup> optional	Hi, Comfort T100 Wi-Fi <sup>(1)</sup> optional	up to 1:8	8 8 8	6 m	27 27 21	63 63 53
715 x 405 x 248 780 x 400 x 338 -	Hi, Comfort T100 <sup>(2)</sup> optional	Hi, Comfort T100 Wi-Fi <sup>(1)</sup> optional	up to 1:3	8	6 m	27 21	63 53
740 x 420 x 275	Hi, Comfort T100 <sup>(2)</sup> optional	Hi, Comfort T100 Wi-Fi <sup>(1)</sup> optional	up to 1:8	9 9	modulating up to 7 m	24 25	65 62

(1) Need 1 pc. of the Hi Control, Comfort T100 Wi-Fi (cod. 20193354) or 1 pc. of the Hi control, Comfort T100 (cod. 20193352) with 1 pc. of the external temperature probe kit with connector (cod. 1220559)

(2) Required 1 pc. of the Command Hi, Comfort T100 (cod. 20193352)

(3) Combined boilers only



(4) Need 3 pcs. of the Hi Control, Comfort T100 (cod. 20193352) with 1 pc. of the external temperature probe kit with connector (COD. 1220559)

(5) Maximum development in length of the intubation (maximum value with Bertetta smoke Ø50 class H1 or Ø60 class H1). The length is in addition to a split smoke and air line at the boiler outlet. Smoke: 4.5 m Ø80 + 1 curve Ø80 at 90°; Air: 4.5 m Ø80 + 1 curve Ø80 at 90°

(6) The system achieves class A+ in combination with T300 or T100.

Condensing wall-hung

## PRODUCT MATRIX OF BERETTA CONDENSING WALL-HUNG BOILERS

PRODUCT	MAXIMUM LENGTH (m)				
	type B23 installation 80 mm Exhaust Air intake in the environment	DOUBLE 80 mm Exhaust Air intake 80 mm	COAXIAL 60/100 VERTICAL	COAXIAL 60/100 HORIZONTAL	COAXIAL 80/125
Exclusive Evo X	120 (25 kW) 60 (30 kW) 60 (35 kW)	69 + 69 (25 kW) 36 + 36 (30 kW) 36 + 36 (35 kW)	11 (25 kW) 9 (30 kW) 9 (35 kW)	10 (25 kW) 8 (30 kW) 8 (35 kW)	25 (25 kW) 20 (30 kW) 20 (35 kW)
Mynute Evo X	120 (20 kW) 120 (25 kW) 60 (30 kW) 60 (35 kW)	69 + 69 (20 kW) 69 + 69 (25 kW) 36 + 36 (30 kW) 36 + 36 (35 kW)	11 (20 kW) 11 (25 kW) 9 (30 kW) 9 (35 kW)	10 (20 kW) 10 (25 kW) 8 (30 kW) 8 (35 kW)	25 (20 kW) 25 (25 kW) 20 (30 kW) 20 (35 kW)
Mynute Boiler Evo X					
Ciao X 	48 (15/25 kW) 40 (30 kW)	33 + 33 (15/25 kW) 27 + 27 (30 kW)	6,85 (15/25 kW) 5,85 (30 kW)	5,85 (15/25 kW) 4,85 (30 kW)	14 (15/25 kW) 12 (30 kW)
BLR					
Meteo X  	48 (25 kW) 40 (30 kW)	52 + 52 (25 kW) 45 + 45 (30 kW)	11 (25 kW) 5,85 (30 kW)	10 (25 kW) 4,85 (30 kW)	25 (25 kW) 12 (30 kW)

# HEAD CURVES OF STANDARD AND HIGH HEAD CIRCULATING PUMPS

## EXCLUSIVE EVO X

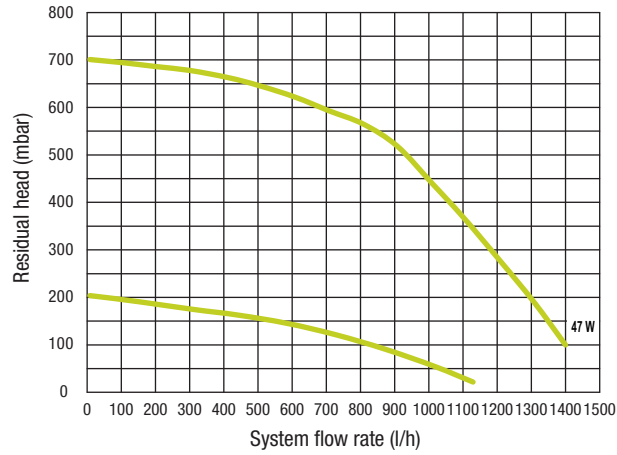

## MYNUTE EVO X

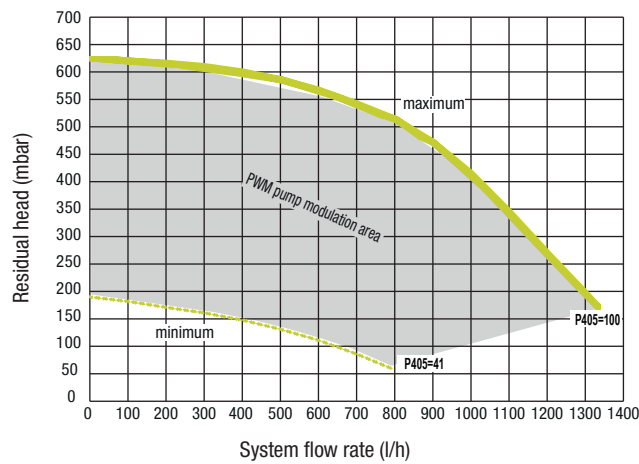

## MYNUTE BOILER EVO X

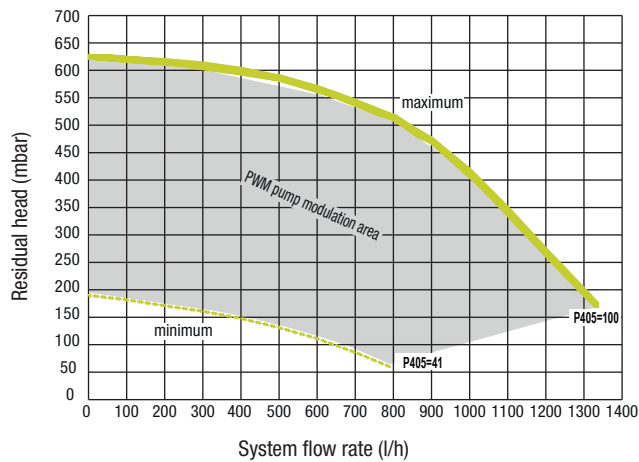

Condensing wall-hung

## HEAD CURVES OF STANDARD AND HIGH HEAD CIRCULATING PUMPS

### CIAO X

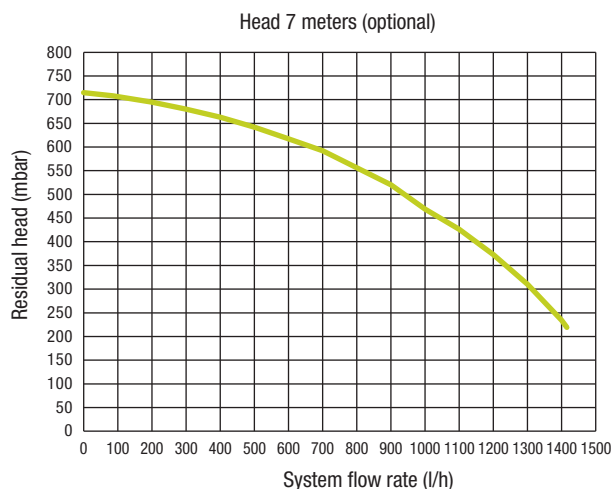
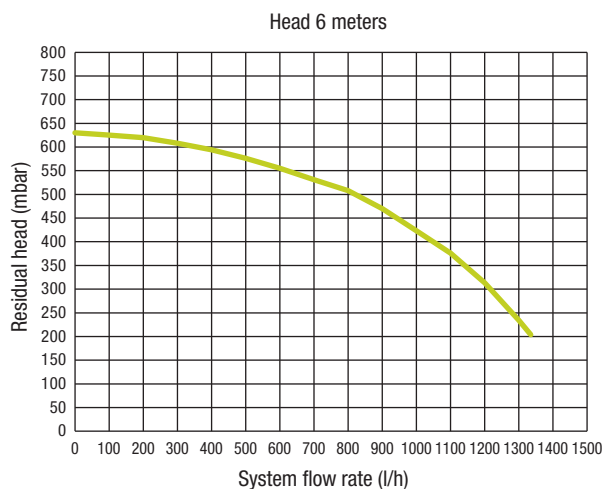

### BLR

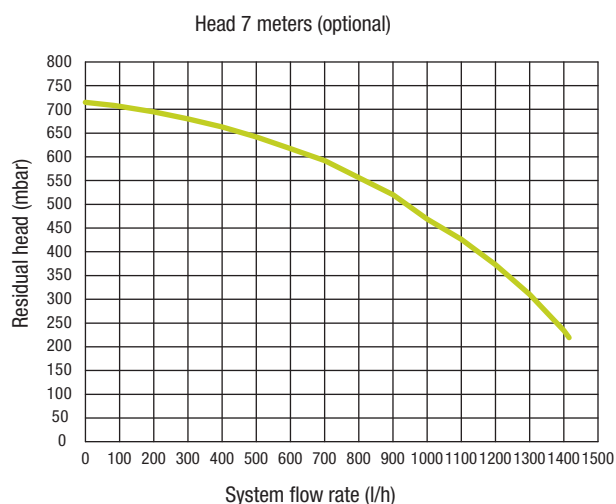
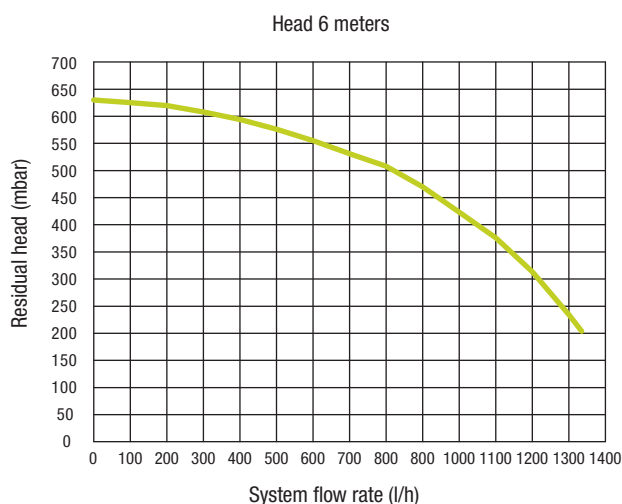

### METEO X

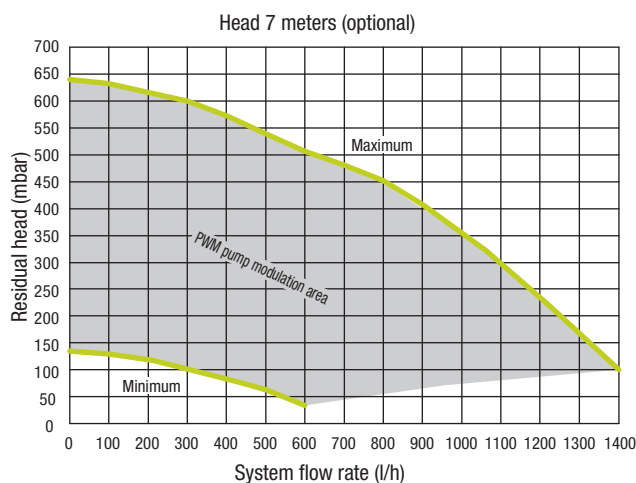

Note: for the ranges of boilers not mentioned in the graphs above refer to the corporate website to download the instructions manuals.  
Beretta reserves the right to change the data without prior notice. In order to have always updated data, it is possible to consult the documentation available on the corporate website.



- High efficiency thanks to new-generation adaptive combustion control, extensive modulation and renewed exchangers
- Excellent DHW comfort, quick set-point and temperature stability
- Very high 1:13 modulation
- IoT READY
- New advanced, full-colour and full-touch interface with guided user tour
- Elegant and compact design for easy integration into domestic environments
- Hydraulic unit with standard DIN sequence connections for universal installation and replacement
- Low noise level of up to 45 dB
- High-efficiency increased sanitary heat exchanger
- Prepared for integration into Bertetta Hybrid Ready systems
- 9 litre expansion tank
- Designed to operate with mixtures of NATURAL GAS and HYDROGEN, up to a maximum of 20%.
- Low polluting emissions CLASS 6 (UNI EN 15502)

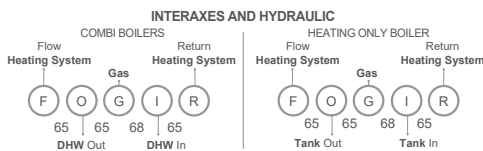











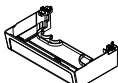

**PREMIX CONDENSING**

CODE	MODEL	GAS (1)	DIMENSIONS H x W x D (mm)	CH INPUT DHW INPUT MIN - MAX (kW)	DHW PRODUCTION (l/min. - Δt 25 °C)	ENERGY EFFICIENCY CLASS	
						(D→A+++)*	(F→A+)*
<b>INSTANTANEOUS COMBI BOILERS</b>							
20206141	EXCLUSIVE EVO X 25C	MTN/GPL	740 x 420 x 275	1,90 - 20,00 1,90 - 25,00	14,3	A	A
20206142	EXCLUSIVE EVO X 30C	MTN/GPL	740 x 420 x 275	2,70 - 25,00 2,70 - 30,00	17,2	A	A
20206143	EXCLUSIVE EVO X 35C	MTN/GPL	740 x 420 x 275	2,70 - 32,00 2,70 - 34,90	20,0	A	A
<b>HEATING ONLY BOILERS</b>							
20206144	EXCLUSIVE EVO X 25R	MTN/GPL	740 x 420 x 275	1,90 - 20,00 1,90 - 25,00	-	A	-
20206145	EXCLUSIVE EVO X 35R	MTN/GPL	740 x 420 x 275	2,70 - 32,00 2,70 - 34,90	-	A	-

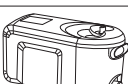
The "heating only" models are supplied with a three-ways valve. Filling tap not available.

(\*) HEATING: the energy efficiency class of the products ranges from D up to A+++ / DHW: the energy efficiency class of the products ranges from F up to A+

(1) The LPG trasformation kit is not necessary. Thanks to the new ACC combustion system, the gas commutation is via electronic setting.

ACCESSORIES		
CODE	DESCRIPTION	IMAGE
<b>IN- WALL INSTALLATION</b>		
20161604	In-wall installation unit <sup>(1)</sup>	
20191887	Crossbar for in-wall installation	
<b>MECHANICAL ACCESSORIES</b>		
20190324	Air Filter <sup>(2)</sup>	
20191519	Hydraulic low fittings cover	
20209808	Dummy boiler EXCLUSIVE EVO X 25 C Dummy boiler for demonstration purposes (not working). Life size: 740 x 420 x 275 mm. Comes with Beretta screen-printed door casing, flue gas outlet, user interface display and boiler label.	
<b>HYDRAULIC ACCESSORIES</b>		
20191518	Compact polyphosphate doser kit	
20191517	Compact magnetic filter	
20192808	Board BE09 with double multi-function relay <sup>(3)</sup>	
20097192	Condensate booster pump kit	
20210993	High residual pump 7,5 m	
20035644	Solar diverter valve kit for instant wall-hung combined boilers	
1220599	Well probe for remote heater (for heating only version)	
20133516	Connection kit with heating system, domestic water and gas cocks (for combi models) Kit containing: 2 cocks (flow and return), 1 gas cock, 1 DHW cock, 2 copper pipes (DHW inlet and outlet), 2 copper pipes (heating flow and return), 2 x 1/2" compression fittings, 2 x 3/4" compression fittings, 2 x 1/2" hexagonal nuts and 2 x 3/4" hexagonal nuts. Complete with a set of flat gaskets.	
20133517	Connection kit with heating system and gas cocks (for heating only models) Kit containing: 2 cocks (flow and return), 1 gas cock, 2 copper pipes (heating flow and return), 2 x 3/4" compression fittings and 2 x 3/4" hexagonal nuts. Complete with a set of flat gaskets.	
20132005	Connection kit with domestic water and gas cocks (for combi models) Kit containing: 1 gas cock, 1 DHW cock, 2 copper pipes (DHW inlet and outlet), 2 copper pipes (heating flow and return), 2 x 1/2" compression fittings, 2 x 3/4" compression fittings, 2 x 1/2" hexagonal nuts and 2 x 3/4" hexagonal nuts. Complete with a set of flat gaskets.	

CODE	DESCRIPTION	IMAGE
20133386	Connection kit with gas cock (for heating only models)	
20192806	Flexible fittings for boiler replacement	
<b>COMPLEMENTARY ACCESSORIES</b>		
20191888	Antifreeze heaters -15 °C <sup>(4)</sup>	
1220559	External probe kit The external probe kit detects the outside temperature and activates the climate control programme. Wall mount and connect directly to the boiler board. External probe not required if the boiler is used with a Hi, Comfort T100 Wi-Fi thermostat	
1220639	Limit thermostat for low temperature installations	
<b>SPECIFIC FLUES</b>		
20217921	Split connection system kit Ø80 mm	
20164664	Ø80 mm clapet kit for pressurized collective flues	
20164662	Ø80/125 mm concentric clapet kit for pressurized collective flues	
20129175	Wall-hung collector Ø60/100 mm	
20129176	Telescopic wall-hung collector Ø60/100 mm	
20129177	Vertical collector Ø60/100 mm	
20129174	Vertical connection stub pipe kit Ø60/100 mm <sup>(5)</sup>	
20129172	90° bend kit Ø60/100 mm for boiler start <sup>(6)</sup>	
20134830	Adjustable splitter kit from Ø60/100 mm to Ø80/80 mm	
20129769	Adaptor kit B23 Ø80 mm	
20129768	Splitter device kit B23 Ø80 mm for in-wall installation box	
20190475	Compact adjustable splitter device kit from 60/100 mm to 80/80 mm	

# Wall-hung condensing boilers

## EXCLUSIVE EVO X

CODE	DESCRIPTION	IMAGE
<b>ADVANCED ENVIRONMENT CONTROL EXPANSION BOARDS</b>		
20168672	Solar interface kit <sup>(7)</sup>	
20132795	First zone management kit (MIX or DIR zone) <sup>(7)(8)(14)</sup>	
20132796	Additional zone management kit (MIX or DIR zone) <sup>(7)(8)(9)(14)</sup>	
<b>DISTRIBUTION MODULES WITHOUT SEPARATOR</b>		
20130801	CONNECT HYBRID 1D MODULE <sup>(10)(11)</sup>	
20130802	CONNECT HYBRID 2D MODULE <sup>(10)(11)</sup>	
20130803	CONNECT HYBRID 1D+1M MODULE <sup>(10)(12)</sup>	
20130808	IN- WALL INSTALLATION BOX <sup>(13)</sup>	
20131752	Taps kit for BAG3 HYBRID system side and heat pump	

(1) Unit supplied with door.

(2) Ideal to avoid introducing impurities from the intake air into the exchanger and burner.

(3) Ideal board for managing additional circulator, alarm remote kit and zone valve.

(4) The antifreeze heater kit protects the DHW circuit from freezing where temperatures fall below 0°C (down to -15°C), using the copper fitting accessory kits (not flexible)

(5) Code necessary for vertical exhaust with flue system. Accessory already included in kit 20129177.

(6) Code necessary for horizontal exhaust with flue system Ø60/100 mm. Accessory already included in kits 20129175 and 20129176.

(7) Pair with Hi, Comfort T300

(8) Allows you to manage a MIX zone (pump + 3-point mixer valve) or DIR zone (only pump). Not necessary if the Connect Hybrid kit is purchased.

(9) The first zone management kit must always be present. The boiler can manage up to 3 zones in total.

(10) Supplied without built-in Box.







(11) Equipped as standard with limit thermostat for low temperature systems.

(12) Mixed zone equipped as standard with limit thermostat for low temperature systems.

(13) Recessed wall box in galvanised sheet metal (can be painted white). Mandatory with CONNECT HYBRID.

(14) Mandatory accessory when using REC10MHC or T300 for zone management.

**HI, COMFORT CONTROLS FOR DOMESTIC COMFORT**

CODE	DESCRIPTION	IMAGE
20205322	Hi, Comfort T300 <sup>(1)(2)(3)(4)</sup>	
20134478	Alimentatore T300 - REC 10MHC	
20211852	Hi, Comfort T200 <sup>(5)(6)</sup>	
20193354	Hi, Comfort T100 Wi-Fi <sup>(7)</sup>	
20193352	Hi, Comfort T100 <sup>(8)</sup>	
20193355	Hi, Comfort G100-W	
20193356	Hi, Comfort G100-R	

(1) Wi-fi as standard.

(2) Compatible with heat pumps HYDRO UNIT M.

(3) For lengths longer than 30m, add code 20134478.

(4) Device provided with gateway.

(5) Room thermostat for multi-room applications. Pair with Hi, Comfort T300.

(6) Hi, Comfort T200 paired with Hi, Comfort T300 in RF. enables zone management.

(7) With Wi-Fi Box Hi, Comfort G100-W included for Internet connection via home ADSL Wi-Fi router.

(8) For cable connection to the boiler. Compatible for radio frequency connection with Hi, Comfort G100-W code 20193355 (accessory not included and necessary for Internet connection via home ADSL router).



# Wall-hung condensing boilers

## MYNUTE EVO X



- Stainless steel primary heat exchanger, robust and high efficiency
- Combined and heating-only models, indoor, built-in and in partially protected locations
- High modulation 1:10
- Internet connection via the Hi, Comfort platform
- Hydraulic unit with sequence standard DIN connections
- Digital HMI: touch display, icons and multilingual texts
- Low noise up to 45 dB
- Increased DHW production with high performance sanitary heat exchanger
- Next-generation self-adaptive combustion control
- Compatible with Beretta Hybrid Ready systems
- Gas transformation (Propane Air, LPG) selectable with electronic parameter
- 9 litre expansion tank
- It has been designed to work with mixtures of NATURAL GAS and HYDROGEN, up to a maximum of 20%
- Low polluting emissions CLASS 6 (UNI EN 15502)
- Flues can be ducted with PP pipes (Ø60 and Ø50)
- Template supplied

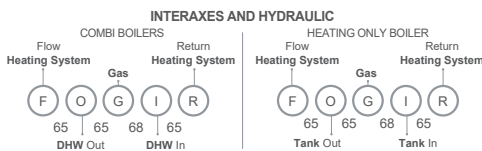

### PREMIX CONDENSING











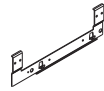

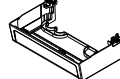
CODE	MODEL	GAS (1)	DIMENSIONS H x W x D (mm)	CH INPUT DHW INPUT MIN - MAX (kW)	DHW PRODUCTION (l/min. - Δt 25 °C)	ENERGY EFFICIENCY CLASS	
						(D→A+++)*	(F→A+)*
<b>INSTANTANEOUS COMBI BOILERS</b>							
20205312	MYNUTE EVO X 25 C	NG/LPG	740 x 420 x 275	2,50 - 20,00 2,50 - 25,00	14,3	A	A
20205313	MYNUTE EVO X 30 C	NG/LPG	740 x 420 x 275	3,00 - 25,00 3,00 - 30,00	17,2	A	A
20205314	MYNUTE EVO X 35 C	NG/LPG	740 x 420 x 275	3,50 - 30,00 3,50 - 34,90	20,0	A	A
<b>HEATING ONLY BOILERS</b>							
20205315	MYNUTE EVO X 20 R (2)	NG/LPG	740 x 420 x 275	2,50 - 20,00 2,50 - 20,00	-	A	-
20205316	MYNUTE EVO X 30 R (2)	NG/LPG	740 x 420 x 275	3,50 - 30,00 3,50 - 34,90	-	A	-



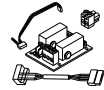
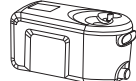

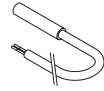







The "heating only" models are supplied with a three-ways valve. Filling tap not available.

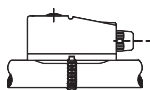
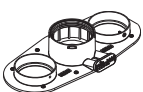

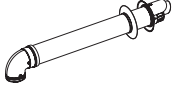
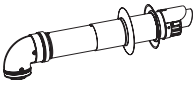





(\*) HEATING: the energy efficiency class of the products ranges from D up to A+++ / DHW: the energy efficiency class of the products ranges from F up to A+

(1) The LPG transformation kit is not necessary. Thanks to the new ACC combustion system, the gas commutation is via electronic setting.

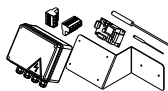
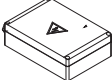
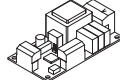
**ACCESSORIES**

CODE	DESCRIPTION	IMAGE
<b>IN- WALL INSTALLATION</b>		
20161604	In-wall installation unit <sup>(1)</sup>	
20191887	Crossbar for in-wall installation	
<b>MECHANICAL ACCESSORIES</b>		
20190324	Air Filter <sup>(2)</sup>	
20191519	Hydraulic low fittings cover	
20209805	Dummy boiler MYNUTE EVO X Dummy boiler for demonstration purposes (not working). Life size: 740 x 420 x 275 mm. Comes with Beretta screen-printed door casing, flue gas outlet, user interface display and boiler label.	
<b>HYDRAULIC ACCESSORIES</b>		
20191518	Compact polyphosphate doser kit	
20191517	Compact magnetic filter	
20192808	Board BE09 with double multi-function relay <sup>(3)</sup>	
20097192	Condensate booster pump kit	
20210993	High residual pump 7,5 m	
20035644	Solar diverter valve kit for instant wall-hung combined boilers	
1220599	Well probe for remote heater (for heating only version)	
20133516	Connection kit with heating system, domestic water and gas cocks (for combi models) Kit containing: 2 cocks (flow and return), 1 gas cock, 1 DHW cock, 2 copper pipes (DHW inlet and outlet), 2 copper pipes (heating flow and return), 2 x 1/2" compression fittings, 2 x 3/4" compression fittings, 2 x 1/2" hexagonal nuts and 2 x 3/4" hexagonal nuts. Complete with a set of flat gaskets.	
20133517	Connection kit with heating system and gas cocks (for heating only models) Kit containing: 2 cocks (flow and return), 1 gas cock, 2 copper pipes (heating flow and return), 2 x 3/4" compression fittings and 2 x 3/4" hexagonal nuts. Complete with a set of flat gaskets.	
20132005	Connection kit with domestic water and gas cocks (for combi models) Kit containing: 1 gas cock, 1 DHW cock, 2 copper pipes (DHW inlet and outlet), 2 copper pipes (heating flow and return), 2 x 1/2" compression fittings, 2 x 3/4" compression fittings, 2 x 1/2" hexagonal nuts and 2 x 3/4" hexagonal nuts. Complete with a set of flat gaskets.	

CODE	DESCRIPTION	IMAGE
2013386	Connection kit with gas cock (for heating only models)	
20192806	Flexible fittings for boiler replacement	
<b>COMPLEMENTARY ACCESSORIES</b>		
20191888	Antifreeze heaters -15 °C <sup>(4)</sup>	
1220559	External probe kit The external probe kit detects the outside temperature and activates the climate control programme. Wall mount and connect directly to the boiler board. External probe not required if the boiler is used with a Hi, Comfort T100 Wi-Fi thermostat	
1220639	Limit thermostat for low temperature installations	
<b>SPECIFIC FLUES</b>		
20217921	Split connection system kit Ø80 mm	
20164664	Ø80 mm clapet kit for pressurized collective flues	
20164662	Ø80/125 mm concentric clapet kit for pressurized collective flues	
20129175	Wall-hung collector Ø60/100 mm	
20129176	Telescopic wall-hung collector Ø60/100 mm	
20129177	Vertical collector Ø60/100 mm	
20129174	Vertical connection stub pipe kit Ø60/100 mm <sup>(5)</sup>	
20129172	90° bend kit Ø60/100 mm for boiler start <sup>(6)</sup>	
20134830	Adjustable splitter kit from Ø60/100 mm to Ø80/80 mm	
20129769	Adaptor kit B23 Ø80 mm	

CODE	DESCRIPTION	IMAGE
20129768	Splitter device kit B23 Ø80 mm for in-wall installation box	
20190475	Compact adjustable splitter device kit from 60/100 mm to 80/80 mm	
<b>ADVANCED ENVIRONMENT CONTROL EXPANSION BOARDS</b>		
20168672	Solar interface kit <sup>(7)</sup>	
20132795	First zone management kit (MIX or DIR zone) <sup>(7)(8)(14)</sup>	
20132796	Additional zone management kit (MIX or DIR zone) <sup>(7)(8)(9)(14)</sup>	
<b>DISTRIBUTION MODULES WITHOUT SEPARATOR</b>		
20130801	CONNECT HYBRID 1D MODULE <sup>(10)(11)</sup>	
20130802	CONNECT HYBRID 2D MODULE <sup>(10)(11)</sup>	
20130803	CONNECT HYBRID 1D+1M MODULE <sup>(10)(12)</sup>	
20130808	IN- WALL INSTALLATION BOX <sup>(13)</sup>	
20131752	Taps kit for BAG3 HYBRID system side and heat pump	

(1) Unit supplied with door.

(2) Ideal to avoid introducing impurities from the intake air into the exchanger and burner.

(3) Ideal board for managing additional circulator, alarm remote kit and zone valve.

(4) The antifreeze heater kit protects the DHW circuit from freezing where temperatures fall below 0°C (down to -15°C), using the copper fitting accessory kits (not flexible)

(5) Code necessary for vertical exhaust with flue system. Accessory already included in kit 20129177.

(6) Code necessary for horizontal exhaust with flue system Ø60/100 mm. Accessory already included in kits 20129175 and 20129176.

(7) Pair with Hi, Comfort T300

(8) Allows you to manage a MIX zone (pump + 3-point mixer valve) or DIR zone (only pump). Not necessary if the Connect Hybrid kit is purchased.

(9) The first zone management kit must always be present. The boiler can manage up to 3 zones in total.

(10) Supplied without built-in Box.







(11) Equipped as standard with limit thermostat for low temperature systems.

(12) Mixed zone equipped as standard with limit thermostat for low temperature systems.

(13) Recessed wall box in galvanised sheet metal (can be painted white). Mandatory with CONNECT HYBRID.

(14) Mandatory accessory when using REC10MHC or T300 for zone management.

**HI, COMFORT CONTROLS FOR DOMESTIC COMFORT\***

CODE	DESCRIPTION	IMAGE
20205322	Hi, Comfort T300 (1)(2)(3)(4)	
20134478	T300 - REC 10MHC Power supply unit (9)	
20211852	Hi, Comfort T200 (5)(6)	
20193354	Hi, Comfort T100 Wi-Fi (7)	
20193352	Hi, Comfort T100 (8)	
20193355	Hi, Comfort G100-W	
20193356	Hi, Comfort G100-R	

(\*) Possibility of ON/OFF connection: for further details, refer to the pages dedicated to the Hi, Comfort Control in the THERMOREGULATION section of the Price List Catalogue.

(1) Wi-fi as standard.

(2) Compatible with heat pumps HYDRO UNIT M.

(3) For lengths longer than 30m, add code 20134478.

(4) Device provided with gateway.

(5) Room thermostat for multi-room applications. Pair with Hi, Comfort T300.

(6) Hi, Comfort T200 paired with Hi, Comfort T300 in RF. enables zone management.

(7) With Wi-Fi Box Hi, Comfort G100-W included for Internet connection via home ADSL Wi-Fi router.

(8) For cable connection to the boiler. Compatible for radio frequency connection with Hi, Comfort G100-W code 20193355 (accessory not included and necessary for Internet connection via home ADSL router).

(9) Mandatory accessory when using REC10MHC or T300 for zone management.



# Wall-hung condensing boilers

## MYNUTE BOILER EVO X



- Combined boiler with 30-liter stainless steel bitank, available with dedicated code
- Simple two-step installation: installation of the bi-tank and of the boiler on it
- Advanced electronics and possibility of enabling and disabling boiler operation in combination with the bi-tank
- Robust, high-efficiency stainless steel primary heat exchanger
- High modulation ratio 1:10
- Hydraulic unit with sequence standard DIN connections
- IPX5D electrical protection degree
- Modern and intuitive digital user interface: touch display, icons and multilingual texts
- Designed to operate with natural gas and hydrogen mixtures, up to a maximum of 20%
- Gas conversion (propane air, LPG) selectable with electronic parameter

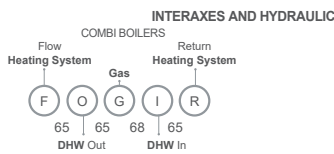

### PREMIX CONDENSING

CODE	MODEL	DIMENSIONS H x W x D (mm)	CH INPUT DHW INPUT MIN - MAX (kW)	DHW PRODUCTION (l/min. - Δt 25 °C)	ENERGY EFFICIENCY CLASS	
					(D→A+++)*	(F→A+)*
<b>INSTANTANEOUS COMBI BOILERS</b>						
20222588	MYNUTE BOILER EVO X 25 B	740 x 420 x 275	2,50 - 20,00 2,50 - 25,00	14,3	A	A
20222590	MYNUTE BOILER EVO X 35 B	740 x 420 x 275	3,5 - 30,0 3,5 - 34,9	20,0	A	A













(\*) HEATING: the energy efficiency class of the products ranges from D up to A+++ / DHW: the energy efficiency class of the products ranges from F up to A+  
 DIMENSIONS OF BOILER WITH BI-TANK STORAGE H x W x D (mm): 843\* x 420 x 470  
 \*height including fittings cover

**COMMERCIAL SETS**

CODE	DESCRIPTION
20225085	Mynute boiler EVO X 25B with compact polyphosphate doser kit as standard
20222588	Mynute boiler EVO X 25B
20213360	Dosseret bi-tank - 25 kW
20214145	Fittings for bi-tank- 30 kW
20213415	Flow switch kit and fittings - 25kW (for composition with doser kit)
20191518	Compact polyphosphate doser kit
20216906	Low fitting cover
20225090	Mynute boiler EVO X 25B without compact polyphosphate doser kit as standard
20222588	Mynute boiler EVO X 25B
20213360	Dosseret bi-tank - 25 kW
20214145	Fittings for bi-tank- 30 kW
20213431	Flow switch kit and fittings - 25 kW (for composition without doser kit)
20216906	Low fitting cover
20225091	Mynute boiler EVO X 35B with compact polyphosphate doser kit as standard
20222590	Mynute boiler EVO X 35B
20213360	Dosseret bi-tank - 25 kW
20214145	Fittings for bi-tank- 30 kW
20213415	Flow switch kit and fittings - 25kW (for composition with doser kit)
20191518	Compact polyphosphate doser kit
20216906	Low fitting cover
20225092	Mynute boiler EVO X 35B without compact polyphosphate doser kit as standard
20222590	Mynute boiler EVO X 35B
20213360	Dosseret bi-tank - 25 kW
20214145	Fittings for bi-tank- 30 kW
20213431	Flow switch kit and fittings - 25 kW (for composition without doser kit)
20216906	Low fitting cover

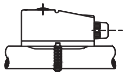
# Wall-hung condensing boilers

## MYNUTE BOILER EVO X

ACCESSORIES		
CODE	DESCRIPTION	IMAGE
<b>SPECIFIC ACCESSORIES FOR COMMERCIAL SETS</b>		
20213360	Dosseret bi-tank - 25 kW <sup>(1)</sup>	
20213361	Fittings for bi-tank- 25 kW <sup>(2)</sup>	
20213415	Flow switch kit and fittings - 25 kW (for composition with doser kit) <sup>(3)</sup>	
20191518	Compact polyphosphate doser kit <sup>(4)</sup>	
20213431	Flow switch kit and fittings - 25 kW (for composition without doser kit) <sup>(5)</sup>	
20216906	Low fitting cover <sup>(6)</sup>	
<b>HYDRAULIC ACCESSORIES</b>		
20105959	ErP high head circulator <sup>(7)</sup>	
20035644	Solar diverter mixing valve kit (for combination boilers).	
<b>MECHANICAL ACCESSORIES</b>		
20190324	Air filter <sup>(8)</sup>	
<b>COMPLEMENTARY ACCESSORIES</b>		
1220639	Limit thermostat for low temperature systems	
1220559	External probe kit with connector <sup>(9)</sup> The external probe kit detects the outside temperature and activates the climate control programme. Wall mount and connect directly to the boiler board. To be necessarily provided in the case of hybrid systems with the boiler for the management of energy source operation modes.	
20192808	Board BE09 with double multi-function relay <sup>(10)</sup>	
20097192	Condensate booster pump kit <sup>(11)</sup> Piston pump with integrated tank (0.37 liters) specifically designed to evacuate acidic condensates. Kit consisting of No. 1 piston pump, No. 1 integrated detection block, No. 1 W=1.5m connecting cable, No. 2 wires for power supply, No. 2 wires for safety alarm cont., wall mounting bracket.	

## Wall-hung condensing boilers

### MYNUTE BOILER EVO X

CODE	DESCRIPTION	IMAGE
<b>FLUE SYSTEM</b>		
20217921	Fixed split system kit Ø80 mm	
20164664	Ø80 mm clapet kit for pressurized collective flues	
20164662	Ø80/125 mm concentric clapet kit for pressurized collective flues	
20129175	Wall-hung collector Ø60/100 mm	
20129176	Telescopic wall-hung collector Ø60/100 mm	
20129177	Vertical collector Ø60/100 mm	
20129174	Vertical connection stub pipe kit Ø60/100 mm <sup>(12)</sup>	
20129172	90° bend kit Ø60-100 mm for boiler start <sup>(13)</sup>	
20134830	Split system kit with variable position air inlet	
20129769	Adaptor kit B23 from da Ø60/100 up to Ø80 mm	
20190475	Compact adjustable splitter device kit from 60/100 mm to 80/80 mm	

(1) Accessory included in all the commercial sets: 20225085, 20225090, 20225091 and 20225092

(2) Accessory included in all the commercial sets: 20225085, 20225090, 20225091 and 20225092

(3) Accessory included in the commercial sets with compact polyphosphate doser kit as standard: 20225085 and 20225091

(4) Accessory included in the commercial sets with compact polyphosphate doser kit as standard: 20225085 and 20225091

(5) Accessory included in the commercial sets without compact polyphosphate doser kit as standard: 20225090 and 20225092

(6) Accessory included in all the commercial sets: 20225085, 20225090, 20225091 and 20225092

(7) Accessory for boiler only

(8) Ideal to avoid introducing impurities from the intake air into the exchanger and burner.

(9) The external probe kit detects the outside temperature and activates the climate control programme. Wall mount and connect directly to the boiler board. To be necessarily provided in the case of hybrid systems with the boiler for the management of energy source operation modes.

(10) Ideal board for managing additional circulator, alarm remote kit and zone valve.

(11) Piston pump with integrated tank (0.37 liters) specifically designed to evacuate acidic condensates. Kit consisting of No. 1 piston pump, No. 1 integrated detection block, No. 1 W=1.5m connecting cable, No. 2 wires for power supply, No. 2 wires for safety alarm cont., wall mounting bracket.





(12) Code necessary for vertical exhaust with flue system. Accessory already included in kit 20129177.

(13) Code necessary for horizontal exhaust with flue system Ø60/100 mm. Accessory already included in kits 20129175 and 20129176.

# Wall-hung condensing boilers

## MYNUTE BOILER EVO X

### HI, COMFORT CONTROLS FOR DOMESTIC COMFORT\*

CODE	DESCRIPTION	IMAGE
20193354	<b>Hi, Comfort T100 Wi-fi</b> <sup>(1)</sup> Complete kit for Wi-Fi installation, containing room control Hi, Comfort T100 and Hi, Comfort G100-W. The package also includes batteries, connection cables, transformer, screws, dowels, double-sided adhesive tape, magnetic sticker and technical manual. ErP CLASS-CONTRIBUTION: VI-4% (*); I-1% (**).	
20193352	<b>Hi, Comfort T100</b> <sup>(2)</sup> Hi, Comfort T100 room control intended for replacement or new installations, either with single zone or for expansions for Multizone applications. Hi, Comfort T100 is compatible for Internet connection in conjunction with Hi, Comfort G100-W (optional). The package also includes batteries, screws, dowels, double-sided adhesive and technical manual. ErP Class-Contribution: V-3%(*); I-1% (**).	
20193355	<b>Hi, Comfort G100-W</b> <sup>(3)</sup> Wi-Fi box: device that allows connection to the Internet through the home Wi-Fi network. It also allows connection to the boiler BUS for advanced remote management. The package also includes: connection cables, transformer, magnetic sticker.	
20193356	<b>Hi, Comfort G100-W</b> <sup>(4)</sup> RF-Wireless boiler receiver: radio frequency device that allows wireless connection of the RiCLOUD control to the boiler (both on / off and via BUS). It can also be used in cases where the weakness of the Wi-Fi signal does not allow the connection of the Wi-Fi box near the boiler.	

- (1) Complete kit for Wi-Fi installation, containing room control Hi, Comfort T100 and Hi, Comfort G100-W. The package also includes batteries, connection cables, transformer, screws, dowels, double-sided adhesive tape, magnetic sticker and technical manual. ErP CLASS-CONTRIBUTION: VI-4%; I-1% (\*\*).
- (2) Hi, Comfort T100 room control intended for replacement or new installations, either with single zone or for expansions for Multizone applications. Hi, Comfort T100 is compatible for Internet connection in conjunction with Hi, Comfort G100-W (optional). The package also includes batteries, screws, dowels, double-sided adhesive and technical manual. ErP Class-Contribution: V-3%; I-1% (\*\*).
- (3) Wi-Fi box: device that allows connection to the Internet through the home Wi-Fi network. It also allows connection to the boiler BUS for advanced remote management. The package also includes: connection cables, transformer, magnetic sticker.
- (4) RF-Wireless boiler receiver: radio frequency device that allows wireless connection of the RiCLOUD control to the boiler (both on / off and via BUS). It can also be used in cases where the weakness of the Wi-Fi signal does not allow the connection of the Wi-Fi box near the boiler.

(\*) with OT BUS connection.

(\*\*) with ON/OFF management.

Note: When installing the boiler outdoors (built-in in a box or in a partially protected place), the possibility of using the thermostat in Wi-Fi mode must be verified during installation.



# CIAO X



- New stainless steel primary heat exchanger, compact and robust, and high-efficiency sanitary exchanger developed by Beretta
- Easy installation, easy integration even in small spaces and easy replacement, thanks to a wide range of accessories optionally available
- Modern and intuitive touchscreen HMI, with representative icons and capacitive buttons with acoustic "buzzer" to confirm
- Modulation ratio 1:8 and 93% seasonal efficiency
- 8 litre lateral expansion tank
- Hydraulic unit with sequence standard DIN connections
- Compact dimensions 700x400x275 mm and low lifting weight
- New flue flange with dedicated flue system
- Temperature control as standard in combination with the external probe, available as an accessory
- Designed to operate with mixtures of natural gas and hydrogen, up to a maximum of 20%.
- Natural gas operation as standard with possibility of conversion to LPG (G31) and propane air through accessories. This modification must be carried out by the installer or by the technical assistance service
- Easy maintenance and cleaning of the combustion chamber thanks to frontal access to the exchanger
- IPX5D electrical protection
- Class 6 Nox

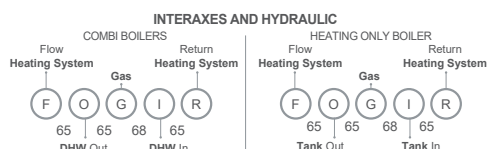

## PREMIX CONDENSING

CODE	MODEL	GAS	DIMENSIONS H x W x D (mm)	CH INPUT DHW INPUT MIN - MAX (kW)	DHW PRODUCTION (l/min. - Δt 25 °C)	ENERGY EFFICIENCY CLASS	
						(D→A+++)*	(F→A+)*
							XL
<b>INSTANTANEOUS COMBI BOILERS</b>							
20187761	CIAO X 25C	NG	700 x 400 x 275	3.10 - 20.00 3.10 - 25.00	14.3	A	A
20187764	CIAO X 25C	LPG	700 x 400 x 275	3.10 - 20.00 3.10 - 25.00	14.3	A	A
20187765	CIAO X 30C	NG	700 x 400 x 275	3.95 - 25.00 3.95 - 30.00	17.2	A	A
<b>HEATING ONLY BOILERS</b>							
20187766	CIAO X 15R	NG	700 x 400 x 275	3.10 - 15.00 3.10 - 25.00	-	A	-
20187767	CIAO X 25R	NG	700 x 400 x 275	5.00 - 20.00 5.00 - 25.00	-	A	-

(\*) HEATING: the energy efficiency class of the products ranges from D up to A+++ / DHW: the energy efficiency class of the products ranges from F up to A+

**SPECIFIC ACCESSORIES FOR IN-WALL INSTALLATION**

CODE	DESCRIPTION	DIMENSIONS H x W x D (mm)
20161604	IN-WALL installation unit (A)	1223 x 654 x 255 (A)
20191887	Crossbar for IN-WALL installation	-

(A) Unit supplied with door.

**ACCESSORIES**

CODE	DESCRIPTION
<b>HYDRAULIC ACCESSORIES</b>	
20191518	Compact polyphosphate doser kit
20191517	Compact magnetic filter
20189142	High residual pump 7M
20192808	Board BE09 with double multi-function relay <sup>(1)</sup>
20097192	Condensate booster pump kit
20035644	Solar diverter valve kit for instant wall-hung combined boilers
1220599	Well probe for remote heater (for heating only version)
20133516	Connection kit with heating system, domestic water and gas cocks (for combi models)
20133517	Connection kit with heating system and gas cocks (for heating only models)
20132005	Connection kit with domestic water and gas cocks (for combi models)
20133386	Connection kit with gas cock (for heating only models)
20192806	Flexible fittings for boiler replacement
<b>MECHANICAL ACCESSORIES</b>	
20190324	Air Filter <sup>(2)</sup>
20191519	Hydraulic low fittings cover
20191884	Dummy boiler Ciao X 25C
20191891	Wall mounting frame 1 pc.
20191892	Wall mounting frame 5 pcs.
<b>COMPLEMENTARY ACCESSORIES</b>	
20191888	Antifreeze heaters -15 °C <sup>(3)</sup>
1220559	External probe kit
1220639	Limit thermostat for low temperature installations
20191520	Building site kit with analogue hydrometer <sup>(4)</sup>
<b>FLUES</b>	
20164664	Ø80 mm clapet kit for pressurized collective flues
20164662	Ø80/125 mm concentric clapet kit for pressurized collective flues
20129175	Wall-hung collector Ø60/100 mm
20129176	Telescopic wall-hung collector Ø60/100 mm

## Combi and 'heating-only' wall-hung boilers condensing boilers

### CIAO X

CODE	DESCRIPTION
20129177	Vertical collector Ø60/100 mm
20129174	Vertical connection stub pipe kit Ø60/100 mm <sup>(5)</sup>
20129172	90° bend kit Ø60/100 mm for boiler start <sup>(6)</sup>
20134830	Adjustable splitter kit from Ø60/100 mm to Ø80/80 mm
20129769	Adaptor kit B23 Ø80 mm
20129768	Splitter device kit B23 Ø80 mm for in-wall installation box
20190475	Compact adjustable splitter device kit from 60/100 mm to 80/80 mm
20129765	Fixed split system kit Ø80 mm
20194628	Ø60/100 mm PP/PPu - Short flue terminal kit <sup>(7)</sup>

(1) Ideal board for managing additional circulator, alarm remote kit and zone valve.

(2) Ideal to avoid introducing impurities from the intake air into the exchanger and burner.

(3) The antifreeze heater kit protects the DHW circuit from freezing where temperatures fall below 0°C (down to -15°C), using the copper fitting accessory kits (not flexible)

(4) Code necessary for horizontal exhaust with flue system Ø60/100 mm.

(5) Code necessary for vertical exhaust with flue system. Accessory already included in kit 20129177.

(6) Code necessary for horizontal exhaust with flue system Ø60/100 mm. Accessory already included in kits 20129175 and 20129176.

(7) Minimum order quantity 50 pcs

### HI, COMFORT CONTROLS FOR DOMESTIC COMFORT\*

CODE	DESCRIPTION
20193354	Thermostat Hi, Comfort T100 Wi-fi <sup>(1)</sup>
20193352	Thermostat Hi, Comfort T100 <sup>(2)</sup>
20193355	Wi-Fi box Hi, Comfort G100-W for internet connection via home ADSL router
20193356	RF - Wireless boiler receiver Hi, Comfort G100-R

(\*) Possibility of ON/OFF connection: for further details, refer to the pages dedicated to the Hi, Comfort Control in the THERMOREGULATION section of the Price List Catalogue.

(1) With Wi-Fi Box Hi, Comfort G100-W included for Internet connection via home ADSL Wi-Fi router.

(2) For cable connection to the boiler. Compatible for radio frequency connection with Hi, Comfort G100-W code 20193355 (accessory not included and necessary for Internet connection via home ADSL router).

# Combi wall-hung boilers condensing boilers BLR

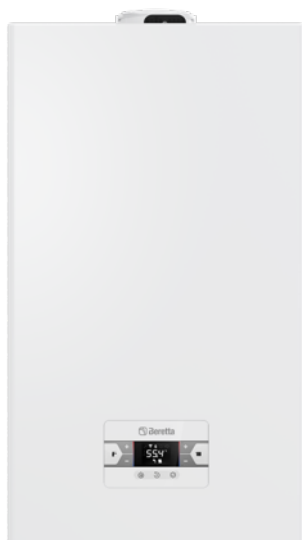

- New stainless steel primary heat exchanger, compact and robust
- Easy installation, easy integration even in small spaces and easy replacement, thanks to a wide range of accessories optionally available
- Hydraulic unit with sequence standard DIN connections
- Designed to operate with mixtures of natural gas and hydrogen, up to a maximum of 20%.
- New flue flange with dedicated flue system
- Temperature control as standard in combination with the external probe, available as an accessory
- Natural gas operation as standard with possibility of conversion to LPG (G31) and propane air through accessories. This modification must be carried out by the installer or by the technical assistance service
- Easy maintenance and cleaning of the combustion chamber thanks to frontal access to the exchanger
- IPX5D electrical protection
- Class 6 Nox

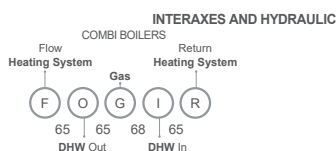

## PREMIX CONDENSING

CODE	MODEL	GAS	DIMENSIONS H x W x D (mm)	CH INPUT DHW INPUT MIN - MAX (kW)	DHW PRODUCTION (l/min. - Δt 25 °C)	ENERGY EFFICIENCY CLASS	
						(D→A+++)*	(F→A+)*

### INSTANTANEOUS COMBI BOILERS

20213289	BLR 25C	NG	700 x 400 x 275	3,1-20,0 / 3,1-25,0	14,3	A	A
20213290	BLR 25C	LPG	700 x 400 x 275	3,1-20,0 / 3,1-25,0	14,3	A	A
20216034	BLR 30C	NG	700 x 400 x 275	3,95-25 / 3,95-30	17,2	A	A

(\*) HEATING: the energy efficiency class of the products ranges from D up to A+++ / DHW: the energy efficiency class of the products ranges from F up to A+  
Pallet: 6 pieces

## SPECIFIC ACCESSORIES FOR IN-WALL INSTALLATION

CODE	DESCRIPTION	DIMENSIONS H x W x D (mm)
20161604	IN-WALL installation unit (*)	1223 x 654 x 255 (+26)
20191887	Crossbar for IN-WALL installation	

(\*) Unit supplied with door.

## Combi wall-hung boilers condensing boilers

### BLR

#### ACCESSORIES

CODE	DESCRIPTION
<b>HYDRAULIC ACCESSORIES</b>	
20191518	Compact polyphosphate doser kit
20191517	Compact magnetic filter
20189142	High residual pump 7M
20192806	Crossover kit DIN vs Beretta <sup>(2)</sup>
20133516	Wall-mounted hydraulic connections and heating, gas and DHW taps kit for combi boilers <sup>(3)</sup>
20132005	Wall-mounted hydraulic connections and gas tap kit for combi boilers <sup>(5)</sup>
20097192	Condensate pump
20035644	Solar diverter mixing valve
<b>MECHANICAL ACCESSORIES</b>	
20190324	Air filter <sup>(7)</sup>
20191519	Hydraulic low fittings cover
20191891	Wall mounting frame 1 pc.
20191892	Wall mounting frame 5 pcs.
<b>COMPLEMENTARY ACCESSORIES</b>	
1220559	Outdoor probe with connector
20191888	Antifreeze heaters -15°C
20192808	Board BE09 with double multi-function relay <sup>(8)</sup>
20191520	Building site kit with analogue hydrometer <sup>(9)</sup>
1220639	Limit thermostat for low temperature applications
20191883	MODBUS control Kit
<b>FLUES</b>	
20164664	Ø80 mm clapet with condensate trap
20164662	Ø80/125 mm clapet with condensate trap
20129175	Ø60/100 mm horizontal flue terminal kit with 90° reduced concentric bend
20129176	Ø60/100 mm telescopic horizontal flue terminal kit with 90° reduced concentric bend
20129177	Ø60/100 mm vertical flue terminal kit with vertical adapter
20129174	Ø60/100 mm vertical adapter kit <sup>(10)</sup>
20129172	Ø60/100 mm - 90° reduced concentric bend kit <sup>(9)</sup>

CODE	DESCRIPTION
20134830	Flue adapter kit from Ø60/100 mm to Ø80+80 mm (air inlet swelling position)
20129768	Flue adapter kit from Ø60/100 mm to Ø80 mm (for type B23 installation) and air inlet
20129769	Vertical flue adapter kit from Ø60/100 mm to Ø80 mm (for type B23 installation) for outdoor
20190475	Compact swelling kit Ø60/100 mm - Ø80/80 mm

(1) Minimum order quantity 50 pcs.

(2) Flexible connections (sanitary, gas and heating) kit required to facilitate the replacement of Ciao X boilers with previous boilers with Bertea standard hydraulic connection sequence.

(3) Kit consists of n.2 taps (flow and return), n.1 gas tap, n.1 domestic water tap, n.2 copper ramps (DHW inlet and outlet), n.2 copper ramps (flow and return), n.2 1/2" compression fittings, n.2 3/4" compression fittings, n.2 1/2" hexagonal nuts, n.2 3/4" hexagonal nuts, set of seals.

(4) Kit consists of n.2 taps (flow and return), n.1 gas tap, n.2 copper ramps (flow and return), n.2 3/4" compression fittings, n.2, n.2 3/4" hexagonal nuts, set of seals.

(5) Kit consists of n.1 gas tap, n.1 domestic water tap, n.2 copper ramps (DHW inlet and outlet), n.2 copper ramps (flow and return), n.2 1/2" compression fittings, n.2 3/4" compression fittings, n.2 1/2" hexagonal nuts, n.2 3/4" hexagonal nuts, set of seals.

(6) Kit consists of n.1 gas tap, n.2 copper ramps (flow and return), n.2 3/4" compression fittings, n.2 3/4" hexagonal nuts, set of seals.

(7) Ideal to avoid introducing impurities from the intake air into the exchanger and burner.

(8) Ideal board for managing additional circulator, alarm remote kit and zone valve.

(9) Code necessary for horizontal exhaust with flue system Ø60/100 mm.

(10) Code necessary for vertical exhaust with flue system. Accessory already included in kit 20129177.

## HI, COMFORT CONTROLS FOR DOMESTIC COMFORT\*

CODE	DESCRIPTION
20193354	Thermostat Hi, Comfort T100 Wi-fi <sup>(1)</sup>
20193352	Thermostat Hi, Comfort T100 <sup>(2)</sup>
20193355	Wi-Fi box Hi, Comfort G100-W for internet connection via home ADSL router
20193356	RF - Wireless boiler receiver Hi, Comfort G100-R

(\*) Possibility of ON/OFF connection: for further details, refer to the pages dedicated to the Hi, Comfort Control in the THERMOREGULATION section of the Price List Catalogue.

(1) With Wi-Fi Box Hi, Comfort G100-W included for Internet connection via home ADSL Wi-Fi router.

(2) For cable connection to the boiler. Compatible for radio frequency connection with Hi, Comfort G100-W code 20193355 (accessory not included and necessary for Internet connection via home ADSL router).



## METEO X



INTERAXES AND HYDRAULIC

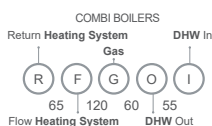

- Layout with electro-galvanized and zinc-magnesium finishes specifically for outdoor installation, top and bottom covers provided as standard
- Frost protection up to  $-15^{\circ}\text{C}$  as standard, electrical protection rating IPX5D
- Stainless steel primary condensing heat exchanger with front accessibility, smooth tube with high section and geometry with a single coil wound
- Native Hybrid Ready system with color REC10MHC remote control panel supplied as standard
- Low consumption modulating circulator ( $\text{EEI} \leq 0,20$ ) with 7m head curve
- 9 liter side expansion tank
- 1:8 modulation ratio
- Arranged to operate with mixtures of natural gas and hydrogen, up to a maximum 20% (in line with environmental sustainability goals and the decarbonization pathway initiated by the European Union)
- C10 certification: possibility of installation in pressurized collective flues via optionally available clapet non-return valve (1)
- Easy plant loading system
- Hydraulic group with Beretta connection sequence, ideal for replacement
- 93% seasonal efficiency
- LPG and Propane or Propane Air conversion kits available. For gas conversion, contact authorized Beretta Technical Service Centers

(1) METEO X is C10 certified in case of natural gas operation



### PREMIX CONDENSING

CODE	MODEL	DIMENSION H x W x D (mm)	CH INPUT DHW INPUT Min - Max (kW)	DHW PRODUCTION (l/min- $\Delta t$ 25°C)	ENERGY EFFICIENCY CLASS	
					(D→A+++)*	(F→A+)*
INSTANTANEOUS COMBI BOILERS						
20191298	METEO X 25C	740 x 420 x 275	3,1-20/3,1-25	14,3	A	A
20191299	METEO X 30C	740 x 420 x 275	3,95-25/3,95-30	17,2	A	A

(\*) HEATING: the energy efficiency class of the products ranges from D up to A+++ / DHW: the energy efficiency class of the products ranges from F up to A+

ACCESSORIES	
CODE	DESCRIPTION
<b>MECHANICAL ACCESSORIES</b>	
20190324	Air filter
<b>HYDRAULIC ACCESSORIES(*)</b>	
20132005	Wall-mounted hydraulic connections and gas tap kit for combi boilers Kit consists of n.1 gas tap, n.1 domestic water tap, n.2 copper ramps (DHW inlet and outlet), n.2 copper ramps (flow and return), n.2 1/2" compression fittings, n.2 3/4" compression fittings, n.2 1/2" hexagonal nuts, n.2 3/4" hexagonal nuts. A set of seals completes the kit.
20133516	Wall-mounted hydraulic connections and heating, gas and DHW taps kit for combi boilers Kit consists of n.2 taps (flow and return), n.1 gas tap, n.1 domestic water tap, n.2 copper ramps (DHW inlet and outlet), n.2 copper ramps (flow and return), n.2 1/2" compression fittings, n.2 3/4" compression fittings, n.2 1/2" hexagonal nuts, n.2 3/4" hexagonal nuts. A set of seals completes the kit.
20035644	Solar diverter mixing valve kit
20192806	Flexible fittings kit for conversion DIN vs Bertetta <sup>(1)</sup>
20191517	Compact magnetic water filter kit
20191518	Compact polyphosphate doser kit
<b>FLUE GAS DISCHARGE ACCESSORIES</b>	
20164662	Concentric clapet kit Ø80 mm for pressurized collective flues
20164664	Clapet kit Ø80 mm for pressurized collective flues
20134830	Split system kit with variable position air inlet
20129172	90° lowered bend kit Ø60/100 mm for boiler start <sup>(2)</sup>
20129174	Ø60/100 mm vertical adapter kit <sup>(3)</sup>
20129175	Ø60/100 mm horizontal flue terminal kit <sup>(3)</sup>
20129176	Ø60/100 mm telescopic terminal kit
20129177	Ø60/100 mm vertical terminal kit
20129765	Split system kit Ø80 mm <sup>(4)</sup>
20129768	B23 split flue discharge adapter Ø80 mm with air inlet <sup>(4)</sup>
20129769	B23 flue discharge adapter from Ø60/100 to Ø80 mm with air intake
<b>COMPLEMENTARY ACCESSORIES</b>	
1220559	Outdoor temperature probe kit with connector The outdoor probe kit allows the outdoor temperature to be detected and the climatic modulation program to be activated. It can be installed on the wall and connected directly into the board present in the boiler. External probe not required if the boiler is combined with Hi, Comfort T100 control (class A+ system). Necessarily to be provided in the case of hybrid systems with the boiler for the management of energy sources operating methods.
1220639	Limit thermostat for low temperature applications
20192808	Board BE09 with double multi-function relay
20097192	Condensate booster pump kit Piston pump with integrated tank (0.37 liters) specifically designed to evacuate acidic condensates. Kit consisting of n. 1 piston pump, n. 1 integrated detection block, n. 1 connecting cable L=1.5m, n. 2 wires for power supply, n. 2 wires for safety alarm counter, wall mounting support
20132795	Control of first DIR/MIX zone (C)
20132796	Control of second/third DIR/MIX zone (C)(D)

(1) Flexible connections (sanitary, gas and heating) kit required to facilitate the replacement of Meteo X boilers with previous boilers with DIN standard hydraulic connection sequence.

(2) Code necessary for horizontal exhaust with flue system Ø60/100 mm. Accessory already included in kits 20129175 and 20129176.

(3) Code required in case of vertical exhaust with flue. Accessory already included in kit 20129177.

(4) Compatible flue accessories in case of removing the top cover and installing the boiler not in the open.

(C) Allows you to manage a MIX zone (pump + 3-point mixer valve) or DIR zone (only pump). Not necessary if the Connect Hybrid kit is purchased.

(D) The first zone management kit must always be present. The boiler can manage up to 3 zones in total.

(\*) Note: accessories not supplied with boilers

## METEO X

### HI, COMFORT CONTROLS FOR MANAGING DOMESTIC COMFORT

CODE	DESCRIPTION
20193354	Thermostat Hi, Comfort T100 Wi-fi <sup>(1)</sup>
20193352	Thermostat Hi, Comfort T100 <sup>(2)</sup>
20193355	Wi-Fi box Hi, Comfort G100-W for internet connection via home ADSL router
20193356	RF - Wireless boiler receiver Hi, Comfort G100-R

(\*) With connection via BUS.

(\*\*) In on/off management.



Combi and 'heating only' wall-hung boilers

## EXCLUSIVE MIX



- Air/gas electronic combustion control = constant efficiency.
- Automatic room-temperature adjustment system (S.A.R.A. Booster).
- User-friendly and intuitive digital back-lit display.
- Easy filling system directly from the panel.
- "Comfort" functions.
- IPX5D electrical protection.
- Built-in thermoregulation (with external probe as option).
- Hydraulic connections cover supplied as standard.
- Modulating fan (only on room-sealed models).
- Hydraulic connections, gas and DHW taps supplied as standard.
- Can be matched with Hi, Comfort Control working as WiFi thermostat in OTBus communication, allowing extensive TOP advantages.

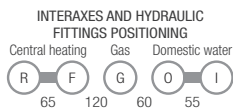

### ROOM-SEALED (MODULATING AIR/GAS)\*

CODE	MODEL	GAS	DIMENSIONS H x W x D (mm)	CH INPUT DHW INPUT MIN - MAX (kW)	DHW PRODUCTION (l/min. - Δt 25 °C)
<b>INSTANTANEOUS COMBI BOILERS</b>					
1150343	EXCLUSIVE MIX 26 C.S.I.	NG	805 x 400 x 332	26.00	15,0
1150673 (**)	EXCLUSIVE MIX 30 C.S.I.	NG	805 x 450 x 332	30.00	17,4
1150383 (**)	EXCLUSIVE MIX 35 C.S.I.	NG	805 x 500 x 332	35.00	20,2
<b>HEATING ONLY BOILERS</b>					
1150353 (**)	EXCLUSIVE MIX 30 R.S.I.	NG	805 x 450 x 332	30.00	-
20029161 (**)	EXCLUSIVE MIX 35 R.S.I.	NG	805 x 500 x 332	35.00	-

(\*) According to the European Directive ERP, the following products are not allowed to be placed on the European market by the manufacturer since 01/08/2015

(\*\*) While stocks last

The "heating only" models is supplied with a three-ways valve. Filling tap not available.

Note: models available only for RUSSIA & CIS Countries.

## EXCLUSIVE MIX

### ACCESSORIES

CODE	DESCRIPTION
<b>COMFORT ACCESSORIES</b>	
20059641	ALPHA DGT WIRELESS digital room thermostat
20059639	ALPHA DGT digital room thermostat
20101748	ALPHA 7D WIRELESS 7-day digital room thermostat
20063872	ALPHA 7D 7-day digital room thermostat
20164477	OTBus interface board
1220559	Outdoor probe with connector
<b>HYDRAULIC ACCESSORIES</b>	
1101989	Heating taps
1101999	Heating taps with filter (for combi models)
1220599	Socket probe for DHW tank - 3m wire (for R.S.I. models)
20025113	Solar diverter mixing valve (including flexible stainless steel connection pipes)
1101979	High head pump (6 metres ) - (for 26/30 C.S.I. models)
<b>SPECIAL ACCESSORIES</b>	
20071580	Dummy Exclusive MIX for POS

### HI, COMFORT CONTROLS FOR DOMESTIC COMFORT\*

CODE	DESCRIPTION
20193354	Thermostat Hi, Comfort T100 Wi-fi <sup>(1)</sup>
20193352	Thermostat Hi, Comfort T100 <sup>(2)</sup>
20193355	Wi-Fi box Hi, Comfort G100-W for internet connection via home ADSL router
20193356	RF - Wireless boiler receiver Hi, Comfort G100-R

(\*) Possibility of ON/OFF connection: for further details, refer to the pages dedicated to the Hi, Comfort Control in the THERMOREGULATION section of the Price List Catalogue.

(1) With Wi-Fi Box Hi, Comfort G100-W included for Internet connection via home ADSL Wi-Fi router.

(2) For cable connection to the boiler. Compatible for radio frequency connection with Hi, Comfort G100-W code 20193355 (accessory not included and necessary for Internet connection via home ADSL router).



Combi and 'heating only' low NOx wall-hung boilers

## MYNUTE LX - MYNUTE S



- On Lx models only:
- New low NOx emissions cooled burner (Class 6 - According to European Directive UNI EN 15502).
- Low Energy, synchronous pump  $EEL \leq 0,20$ .
- Primary heat exchanger in copper.
- DHW plate heat exchanger in stainless steel.
- Two air inlet holes (right and left side).
- Expansion vessel 9 litres.
- Intuitive and easy-to-use control panel with backlit digital display.
- Built-in thermoregulation (external temperature probe as option).
- IPX5D electrical protection.
- Lower cover available as option (for 24 C.S.I., 28 C.S.I., 28 R.S.I. models).
- Hydraulic connections, gas and DHW taps available as option.
- Can be matched with Hi, Comfort Control working as WiFi thermostat in OTBus communication, allowing extensive TOP advantages.

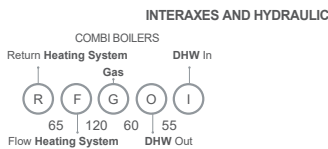

### CONVENTIONAL FLUE

CODE	MODEL	GAS	DIMENSIONS H x W x D (mm)	OUTPUT (kW)	DHW PRODUCTION (l/min. - $\Delta t$ 25 °C)	ENERGY EFFICIENCY CLASS	
						(D→A+++)*	(F→A+)*

#### INSTANTANEOUS COMBI BOILERS

20151436	MYNUTE 24 C.A.I. LX	NG	740 x 400 x 338	24,06	13,8	C	B
20151438	MYNUTE 28 C.A.I. LX	NG	740 x 452 x 338	28,87	16,6	C	B

(\*) HEATING: the energy efficiency class of the products ranges from D up to A+++ / DHW: the energy efficiency class of the products ranges from F up to A+  
 Note: Boilers to be connected only to a flue, shared between multiple dwellings in existing buildings.

### CONVENTIONAL FLUE\*

CODE	MODEL	GAS	DIMENSIONS H x W x D (mm)	OUTPUT (kW)	DHW PRODUCTION (l/min. - $\Delta t$ 25 °C)
------	-------	-----	---------------------------------	----------------	--

#### INSTANTANEOUS COMBI BOILERS

20074588	MYNUTE S 24 C.A.I. E	NG	740 x 400 x 336	24,00	13,7
20069390 (**)	MYNUTE S 28 C.A.I. E	NG	740 x 452 x 336	28,00	16,5

(\*) According to the European Directive ERP, the following products are not allowed to be placed on the European market by the manufacturer since 01/08/2015

(\*\*) While stocks last

Combi and 'heating only' low NOx wall-hung boilers

## MYNUTE LX - MYNUTE S

### ROOM-SEALED\*

CODE	MODEL	GAS	DIMENSIONS H x W x D (mm)	OUTPUT (kW)	DHW PRODUCTION (l/min. - Δt 25 °C)
<b>INSTANTANEOUS COMBI BOILERS</b>					
20069385	MYNUTE S 24 C.S.I.	NG	740 x 400 x 336	24,00	13,9
<b>INSTANTANEOUS COMBI BOILERS</b>					
20069387	MYNUTE S 28 C.S.I.	NG	740 x 400 x 336	28,00	16,0
20069389	MYNUTE S 28 C.S.I.	LPG	740 x 400 x 336	28,00	16,0
20069392 (**)	MYNUTE S 35 C.S.I.	NG	780 x 505 x 336	35,00	20,0
<b>HEATING ONLY BOILERS</b>					
20069391	MYNUTE S 28 R.S.I.	NG	740 x 400 x 336	28,00	-
20069395 (**)	MYNUTE S 35 R.S.I.	NG	780 x 505 x 336	35,00	-

(\*) According to the European Directive ERP, the following products are not allowed to be placed on the European market by the manufacturer since 01/08/2015

(\*\*) While stocks last

The "heating only" models is supplied with a three-ways valve. Filling tap not available.

Note: models available only for RUSSIA & CIS Countries.

### ACCESSORIES

CODE	DESCRIPTION
<b>COMFORT ACCESSORIES</b>	
20059641	ALPHA DGT WIRELESS digital room thermostat
20059639	ALPHA DGT digital room thermostat
20101748	ALPHA 7D WIRELESS 7- day digital room thermostat
20063872	ALPHA 7D 7- day digital room thermostat
1220559	Outdoor probe with connector
<b>HYDRAULIC ACCESSORIES</b>	
1101989	Heating taps
20155079	LPG gas transformation kit for 24 CAI Lx model
20155101	LPG gas transformation kit for 28 CAI Lx model
1101999	Heating taps with filter
1220599	Socket probe for DHW tank - 3m wire (for R.S.I. models)
20025113	Solar diverter valve (including flexible stainless steel connection pipes)
20051629	Lower cover (only for 24 C.S.I., 28 C.S.I., 28 R.S.I. models)
20008794	Hydraulic connections kit (for welding)
20051979	Hydraulic connections kit (with brass nipples)
1101979	High head pump (6 metres) - for non-ErP boilers
20105959	High head Low Energy pump (7 metres) - for ErP boilers

## MYNUTE LX - MYNUTE S

### HI, COMFORT CONTROLS FOR DOMESTIC COMFORT\*

CODE	DESCRIPTION
20193354	Thermostat Hi, Comfort T100 Wi-fi <sup>(1)</sup>
20193352	Thermostat Hi, Comfort T100 <sup>(2)</sup>
20193355	Wi-Fi box Hi, Comfort G100-W for internet connection via home ADSL router
20193356	RF - Wireless boiler receiver Hi, Comfort G100-R

(\*) Possibility of ON/OFF connection: for further details, refer to the pages dedicated to the Hi, Comfort Control in the THERMOREGULATION section of the Price List Catalogue.

(1) With Wi-Fi Box Hi, Comfort G100-W included for Internet connection via home ADSL Wi-Fi router.

(2) For cable connection to the boiler. Compatible for radio frequency connection with Hi, Comfort G100-W code 20193355 (accessory not included and necessary for Internet connection via home ADSL router).



- Primary heat exchanger in copper.
- DHW plate heat exchanger in stainless steel.
- Efficiency ★★★ according to European Directive EEC 92/42.
- Two air inlet holes (right and left side).
- Expansion vessel 8 litres.
- 3-speed circulator 5 metres (4 metres single-speed on 20 kW version).
- Intuitive and easy-to-use control panel with backlit digital display.
- Built-in thermoregulation (external temperature probe as option).
- IPX5D electrical protection.
- Frost protection kit till -10 °C available as option.
- Upper and lower cover available as option.
- Hydraulic connections, gas and DHW taps available as option.
- Can be matched with Hi, Comfort Control working as WiFi thermostat in OTBus communication, allowing extensive TOP advantages.

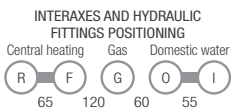

(1) METEO X is C10 certified in case of natural gas operation



**ROOM-SEALED\***

CODE	MODEL	GAS	DIMENSIONS H x W x D (mm)	OUTPUT (kW)	DHW PRODUCTION (l/min. - Δt 25 °C)
<b>INSTANTANEOUS COMBI BOILERS</b>					
20068208	CIAO S 20 C.S.I.	NG	715 x 405 x 248	20,00	11,8
20068204	CIAO S 24 C.S.I.	NG	715 x 405 x 248	24,00	13,7
20068228	CIAO S 24 C.S.I.	LPG	715 x 405 x 248	24,00	13,7
<b>HEATING ONLY BOILERS *</b>					
20068207	CIAO S 24 R.S.I.	NG	715 x 405 x 248	24,00	-

(\*) According to the European Directive ERP, the following products are not allowed to be placed on the European market by the manufacturer since 01/08/2015  
 Note: The "heating only" models is supplied with a three-ways valve. Filling tap not available.

**ACCESSORIES**

CODE	DESCRIPTION
<b>COMFORT ACCESSORIES</b>	
20059641	ALPHA DGT WIRELESS digital room thermostat
20059639	ALPHA DGT digital room thermostat
20101748	ALPHA 7D WIRELESS 7- day digital room thermostat
20063872	ALPHA 7D 7- day digital room thermostat
1220559	Outdoor probe with connector
<b>HYDRAULIC ACCESSORIES</b>	
1101989	Heating taps
1101999	Heating taps with filter
20008794	Hydraulic connections kit (for welding)
20008795	Hydraulic connections kit (with brass nipples)
20025113	Solar diverter mixing valve kit (including flexible stainless steel connection pipes)
1101979	High head pump (6 metres)
1220599	Socket probe for DHW tank - 3m wire (only R.S.I. models)
<b>SPECIAL ACCESSORIES</b>	
20012594	Lower cover
20012595	Upper cover
20164821	Frost protection resistances kit down to -10°C (C.S.I. models)**

(\*\*) Together with the installation of the frost protection resistances kit (code 20164821), it is necessary to install the lower cover (code 20012594).

**HI, COMFORT CONTROLS FOR DOMESTIC COMFORT\***

CODE	DESCRIPTION
20193354	Thermostat Hi, Comfort T100 Wi-fi <sup>(1)</sup>
20193352	Thermostat Hi, Comfort T100 <sup>(2)</sup>
20193355	Wi-Fi box Hi, Comfort G100-W for internet connection via home ADSL router
20193356	RF - Wireless boiler receiver Hi, Comfort G100-R

(\*) Possibility of ON/OFF connection: for further details, refer to the pages dedicated to the Hi, Comfort Control in the THERMOREGULATION section of the Price List Catalogue.

(1) With Wi-Fi Box Hi, Comfort G100-W included for Internet connection via home ADSL Wi-Fi router.

(2) For cable connection to the boiler. Compatible for radio frequency connection with Hi, Comfort G100-W code 20193355 (accessory not included and necessary for Internet connection via home ADSL router).

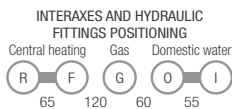

- Single-circuit (R.S.I.) and double-circuit (C.S.I.) CITY wall-hung gas boiler with room-sealed combustion chamber and double-circuit (C.A.I.) CITY wall-hung gas boiler with open combustion chamber, designed for space heating and the supply of DHW for various purposes. These models are ideal for use in flat heating systems.
- Separate heat exchangers for heating and domestic hot water (for C.S.I. and C.A.I.).
- Control panel LCD display.
- Two holes for air duct connection in case of separate chimney and air intake (for R.S.I. and C.S.I.).
- Ability of receiving a lockout signal for remote transmission (using an optional accessory).
- Possibility of connecting a separate boiler - domestic hot water storage tank (for 24-28 R.S.I.).
- Built-in weather compensation function (when an outdoor temperature sensor is installed).
- Three-speed circulation pump.
- Built-in three-way valve for DHW (for CITY R.S.I.).
- Burner with continuous modulating power control.
- Built-in automatic refrigerant temperature control system.
- Built-in wiring and safety systems.
- Protection against freezing and locking of the pump and three-way valve.
- Priority to hot water.
- Capacity to operate with liquefied gas.
- Fault self-diagnosis system with information output on LCD display.
- Option to connect a remote control.

## ROOM-SEALED\*

CODE	MODEL	GAS	DIMENSIONS H x W x D (mm)	OUTPUT (kW)	DHW PRODUCTION (l/min. - Δt 25 °C)
<b>INSTANTANEOUS COMBI BOILERS</b>					
20087846	CITY 24 C.S.I.	NG	715 x 405 x 248	23.90	13.7
20087848	CITY 28 C.S.I.	NG	740 x 400 x 332	28.00	16.1
20049747 (*)	CITY 35 C.S.I.	NG	780 x 505 x 332	34.90	20.0
<b>HEATING ONLY BOILERS</b>					
20087845	CITY 24 C.A.I.	NG	715 x 405 x 248	24.10	-
20087847 (**)	CITY 28 C.A.I.	NG	740 x 400 x 332	29.00	-

(\*) According to the European Directive ERP, the following products are not allowed to be placed on the European market by the manufacturer since 01/08/2015

(\*\*) While stocks last

The "heating only" models is supplied with a three-ways valve. Filling tap not available.

Note: models available only for RUSSIA & CIS Countries.

**CONVENTIONAL FLUE\***

CODE	MODEL	GAS	DIMENSIONS H x W x D (mm)	OUTPUT (kW)	DHW PRODUCTION (l/min. - Δt 25 °C)
<b>INSTANTANEOUS COMBI BOILERS</b>					
20087845	CITY 24 C.A.I.	NG	740 x 400 x 332	24.10	13.8
20087847	CITY 28 C.A.I.	NG	740 x 450 x 332	29.00	16.6

(\*) According to the European Directive ERP, the following products are not allowed to be placed on the European market by the manufacturer since 01/08/2015  
Note: models available only for RUSSIA & CIS Countries.

**ACCESSORIES**

CODE	DESCRIPTION
<b>COMFORT ACCESSORIES</b>	
20059641	ALPHA DGT WIRELESS digital room thermostat
20059639	ALPHA DGT digital room thermostat
20101748	ALPHA 7D WIRELESS 7- day digital room thermostat
20063872	ALPHA 7D 7- day digital room thermostat
1220559	Outdoor probe with connector
<b>HYDRAULIC ACCESSORIES</b>	
1101989	Heating taps
1101999	Heating taps with filter
20008794	Hydraulic connections kit (for welding)
20008795	Hydraulic connections kit (with brass nipples)
20025113	Solar diverter mixing valve kit (including flexible stainless steel connection pipes)
1101979	High head pump (6 metres)
1220599	Socket probe for DHW tank - 3m wire (only R.S.I. models)
<b>SPECIAL ACCESSORIES</b>	
20012594	Lower cover
20012595	Upper cover
20164821	Frost protection resistances kit down to -10°C (C.S.I. models)**

(\*\*) Together with the installation of the frost protection resistances kit (code 20164821), it is necessary to install the lower cover (code 20012594).

**HI, COMFORT CONTROLS FOR DOMESTIC COMFORT\***

CODE	DESCRIPTION
20193354	Thermostat Hi, Comfort T100 Wi-fi <sup>(1)</sup>
20193352	Thermostat Hi, Comfort T100 <sup>(2)</sup>
20193355	Wi-Fi box Hi, Comfort G100-W for internet connection via home ADSL router
20193356	RF - Wireless boiler receiver Hi, Comfort G100-R

(\*) Possibility of ON/OFF connection: for further details, refer to the pages dedicated to the Hi, Comfort Control in the THERMOREGULATION section of the Price List Catalogue.

(1) With Wi-Fi Box Hi, Comfort G100-W included for Internet connection via home ADSL Wi-Fi router.

(2) For cable connection to the boiler. Compatible for radio frequency connection with Hi, Comfort G100-W code 20193355 (accessory not included and necessary for Internet connection via home ADSL router).



# Combi low NOx wall-hung boilers

## QUADRA II LX - QUADRA II



- On Lx models only:
- New low NOx emissions cooled burner (Class 6 - According to European Directive UNI EN 15502).
- Low Energy, synchronous pump  $EEL \leq 0,20$ .
- Primary heat exchanger in copper.
- DHW plate heat exchanger in stainless steel.
- Efficiency ★★★ according to European Directive EEC 92/42 (on room-sealed models).
- Two air inlet holes (right and left side).
- Expansion vessel 8 litres.
- 3-speed circulator, located on the right side of the boiler (no ErP models).
- Intuitive and easy-to-use control panel with backlit digital display.
- Compact dimensions and low lift weight enable a flexible installation with the boiler able to be sited almost anywhere in the home.
- DIN connections, to enable an easy installation both as a replacement or in new buildings with the same configuration.
- Built-in thermoregulation (external temperature probe as option).
- Hydraulic connections, gas and DHW taps available as option.
- QUADRA II can be converted to LPG through specific LPG kit (as option).
- Can be matched with Hi, Comfort Control working as WiFi thermostat in OTBus communication, allowing extensive TOP advantages.

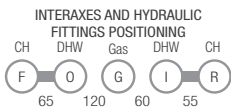

### CONVENTIONAL FLUE

CODE	MODEL	GAS	DIMENSIONS H x W x D (mm)	OUTPUT (kW)	DHW PRODUCTION (l/min. - $\Delta t$ 25 °C)	ENERGY EFFICIENCY CLASS	
						(D→A+++)*	(F→A+)*

#### INSTANTANEOUS COMBI BOILERS

20151439	QUADRA II 24 C.A.I. Lx	NG	740 x 400 x 328	24,06	13,8	C	B
----------	------------------------	----	-----------------	-------	------	---	---

(\*) HEATING: the energy efficiency class of the products ranges from D up to A+++ / DHW: the energy efficiency class of the products ranges from F up to A+  
Note: Boilers to be connected only to a flue, shared between multiple dwellings in existing buildings.

### ROOM-SEALED\*

CODE	MODEL	GAS	DIMENSIONS H x W x D (mm)	OUTPUT (kW)	DHW PRODUCTION (l/min. - $\Delta t$ 25 °C)
------	-------	-----	---------------------------------	----------------	--

#### INSTANTANEOUS COMBI BOILERS

20084087	QUADRA II 24 C.S.I.	NG	715 x 405 x 250	24,00	13,7
20097272	QUADRA II 28 C.S.I.	NG	740 x 400 x 328	28,00	16,3

(\*) According to the European Directive ERP, the following products are not allowed to be placed on the European market by the manufacturer since 01/08/2015

## Combi low NOx wall-hung boilers

### QUADRA II LX - QUADRA II

#### ACCESSORIES

CODE	DESCRIPTION
<b>COMFORT ACCESSORIES</b>	
20059641	ALPHA DGT WIRELESS digital room thermostat
20059639	ALPHA DGT digital room thermostat
20101748	ALPHA 7D WIRELESS 7-day digital room thermostat
20063872	ALPHA 7D 7-day digital room thermostat
1220559	Outdoor probe with connector
<b>HYDRAULIC ACCESSORIES</b>	
1101989	Heating taps
1101999	Heating taps with filter
20008794	Kit hydraulic connections (for welding)
20008795	Kit hydraulic connections (with brass nipples)
20025113	Solar diverter mixing valve (including flexible stainless steel connection pipes)
1101979	High head pump (6 metres) - for non-ErP boilers
20105959	High head Low Energy pump (7 metres) - for ErP boilers
<b>SPECIAL ACCESSORIES</b>	
20012594	Lower cover
20012595	Upper cover
20155105	LPG gas transformation kit for 24 CAI Lx model

#### HI, COMFORT CONTROLS FOR DOMESTIC COMFORT\*

CODE	DESCRIPTION
20193354	Thermostat Hi, Comfort T100 Wi-fi <sup>(1)</sup>
20193352	Thermostat Hi, Comfort T100 <sup>(2)</sup>
20193355	Wi-Fi box Hi, Comfort G100-W for internet connection via home ADSL router
20193356	RF - Wireless boiler receiver Hi, Comfort G100-R

(\*) Possibility of ON/OFF connection: for further details, refer to the pages dedicated to the Hi, Comfort Control in the THERMOREGULATION section of the Price List Catalogue.

(1) With Wi-Fi Box Hi, Comfort G100-W included for Internet connection via home ADSL Wi-Fi router.

(2) For cable connection to the boiler. Compatible for radio frequency connection with Hi, Comfort G100-W code 20193355 (accessory not included and necessary for Internet connection via home ADSL router).



- On Lx models only:
- New low NOx emissions cooled burner (Class 6 - According to European Directive UNI EN 15502).
- Low Energy, synchronous pump  $EEL \leq 0,20$ .
- Bithermic heat-exchanger (for non ErP boilers).
- Efficiency ★★★ according to European Directive EEC 92/42 (on room-sealed models).
- Two air inlet holes (right and left side).
- Expansion vessel 8 litres.
- 4 metres single-speed circulator on 20-24 kW versions (non-ErP boilers).
- 5 metres 3-speed circulator on 28 kW versions (non-ErP boilers).
- Intuitive and easy-to-use control panel with backlit digital display.
- Built-in thermoregulation (external temperature probe as option).
- IPX5D electrical protection.
- Frost protection kit down to -10 °C available as option.
- Upper and lower cover available as option (on 20-24 C.S.I. models).
- Hydraulic connections, gas and DHW taps available as option.
- Can be matched with Hi, Comfort Control working as WiFi thermostat in OTBus communication, allowing extensive TOP advantages.

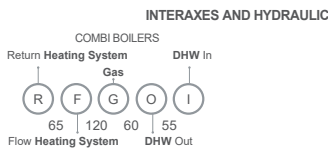

## CONVENTIONAL FLUE

CODE	MODEL	GAS	DIMENSIONS H x W x D (mm)	OUTPUT (kW)	DHW PRODUCTION (l/min. - $\Delta t$ 25 °C)	ENERGY EFFICIENCY CLASS	
						(D→A+++)*	(F→A+)*

### INSTANTANEOUS COMBI BOILERS

20151648	CIAO 24 C.A.I. Lx	NG	740 x 400 x 340	24,06	13,8	C	B
20151437	CIAO 24 C.A.I. Lx		740 x 400 x 340	24,06	13,8	C	B

(\*) HEATING: the energy efficiency class of the products ranges from D up to A+++ / DHW: the energy efficiency class of the products ranges from F up to A+  
 Note: Boilers to be connected only to a flue, shared between multiple dwellings in existing buildings.

## CONVENTIONAL FLUE\*

CODE	MODEL	GAS	DIMENSIONS H x W x D (mm)	OUTPUT (kW)	DHW PRODUCTION (l/min. - $\Delta t$ 25 °C)
------	-------	-----	---------------------------------	----------------	--

### INSTANTANEOUS COMBI BOILERS

20070518 (*)	CIAO 24 C.A.I. e	NG	740 x 400 x 332	24,00	13,6
20070520 (*)	CIAO 28 C.A.I. e	NG	740 x 400 x 332	28,00	16,3

(\*) According to the European Directive ERP, the following products are not allowed to be placed on the European market by the manufacturer since 01/08/2015

(\*\*) While stocks last

## Combi low NOx wall-hung boilers

### CIAO LX - CIAO

#### ROOM-SEALED\*

CODE	MODEL	GAS	DIMENSIONS H x W x D (mm)	OUTPUT (kW)	DHW PRODUCTION (l/min. - $\Delta t$ 25 °C)
<b>INSTANTANEOUS COMBI BOILERS</b>					
20070516 (**)	CIAO 24 C.S.I. e	NG	715 x 405 x 248	24,00	13,7
20070517 (**)	CIAO 28 C.S.I. e	NG	740 x 450 x 332	28,00	16,2
20070522 (**)	CIAO 28 C.S.I. e	NG	740 x 450 x 332	28,00	16,2

(\*) According to the European Directive ERP, the following products are not allowed to be placed on the European market by the manufacturer since 01/08/2015

(\*\*) While stocks last

#### ACCESSORIES

CODE	DESCRIPTION
<b>COMFORT ACCESSORIES</b>	
20059641	ALPHA DGT WIRELESS digital room thermostat
20059639	ALPHA DGT digital room thermostat
20101748	ALPHA 7D WIRELESS 7-day digital room thermostat
20063872	ALPHA 7D 7-day digital room thermostat
1220559	Outdoor probe with connector
<b>HYDRAULIC ACCESSORIES</b>	
1101989	Heating taps
1101999	Heating taps with filter
20025113	Solar diverter valve (including flexible stainless steel connection pipes)
20008794	Kit hydraulic connections (for welding)
20008795	Kit hydraulic connections (with brass nipples)
1101979	High head pump - 6 metres (for 20-24 C.S.I models) - for non-ErP boilers
20105959	High head Low Energy pump (7 metres) - for ErP boilers
<b>SPECIAL ACCESSORIES</b>	
20012594	Lower cover (only for CIAO 20-24 C.S.I)
20012595	Upper cover (only for CIAO 20-24 C.S.I)
20164821	Frost protection resistances kit down to -10°C (only for CIAO 20-24 C.S.I)(*)
20155079	LPG gas transformation kit for 24 CIAI Lx model

(\*) Together with the installation of the frost protection resistances kit (code 20164821), it is necessary to install the lower cover (code 20012594).

**HI, COMFORT CONTROLS FOR DOMESTIC COMFORT\***

CODE	DESCRIPTION
20193354	Thermostat Hi, Comfort T100 Wi-fi <sup>(1)</sup>
20193352	Thermostat Hi, Comfort T100 <sup>(2)</sup>
20193355	Wi-Fi box Hi, Comfort G100-W for internet connection via home ADSL router
20193356	RF - Wireless boiler receiver Hi, Comfort G100-R

(\*) Possibility of ON/OFF connection: for further details, refer to the pages dedicated to the Hi, Comfort Control in the THERMOREGULATION section of the Price List Catalogue.

(1) With Wi-Fi Box Hi, Comfort G100-W included for Internet connection via home ADSL Wi-Fi router.

(2) For cable connection to the boiler. Compatible for radio frequency connection with Hi, Comfort G100-W code 20193355 (accessory not included and necessary for Internet connection via home ADSL router).



- Double-circuit CIAO wall-hung gas boiler with room-sealed (C.S.I.) and open (C.A.I.) combustion chambers designed for heating and hot water production in spaces of various uses. These models are optimal for use in flat heating systems.
- Coaxial heat exchangers for heating and domestic hot water.
- Control panel LCD display.
- Two holes for air duct connection in case of separate flue gas discharge and air intake (for C.S.I.).
- Ability to receive a lockout signal for remote transmission (using an optional accessory).
- Built-in weather-compensated function (when an outdoor temperature sensor is installed).
- Three-speed circulation pump.
- Automatic electric ignition and flame presence monitoring function.
- Burner with continuous power modulation.
- Built-in automatic coolant temperature control system.
- Built-in wiring and safety systems.
- Frost protection and pump lock.
- Hot water priority.
- Operating capability with liquefied gas.
- Fault self-diagnosis system with information output on LCD display.
- Possibility of connecting a remote control.

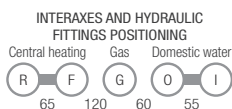

## ROOM-SEALED\*

CODE	MODEL	GAS	DIMENSIONS H x W x D (mm)	OUTPUT (kW)	DHW PRODUCTION (l/min. - Δt 25 °C)
<b>INSTANTANEOUS COMBI BOILERS</b>					
20068314 (**)	CIAO 16 C.S.I.	NG	715 x 405 x 248	16.00	11.8
20048923 (**)	CIAO 24 C.S.I.	NG	715 x 405 x 248	23.90	13.7
20049343 (**)	CIAO 28 C.S.I.	NG	740 x 400 x 332	28.20	16.2

(\*) According to the European Directive ERP, the following products are not allowed to be placed on the European market by the manufacturer since 01/08/2015

(\*\*) While stocks last

Note: models available only for RUSSIA & CIS Countries.

## CONVENTIONAL FLUE\*

CODE	MODEL	GAS	DIMENSIONS H x W x D (mm)	OUTPUT (kW)	DHW PRODUCTION (l/min. - Δt 25 °C)
<b>INSTANTANEOUS COMBI BOILERS</b>					
20049246 (**)	CIAO 24 C.A.I.	NG	740 x 400 x 332	23.80	13.6
20049702 (**)	CIAO 28 C.A.I.	NG	740 x 400 x 332	28.50	16.3

(\*) According to the European Directive ERP, the following products are not allowed to be placed on the European market by the manufacturer since 01/08/2015

(\*\*) While stocks last

The "heating only" models is supplied with a three-ways valve. Filling tap not available.

Note: models available only for RUSSIA & CIS Countries.

**ACCESSORIES**

CODE	DESCRIPTION
<b>COMFORT ACCESSORIES</b>	
20059641	ALPHA DGT WIRELESS digital room thermostat
20059639	ALPHA DGT digital room thermostat
20101748	ALPHA 7D WIRELESS 7-day digital room thermostat
20063872	ALPHA 7D 7-day digital room thermostat
1220559	Outdoor probe with connector
<b>HYDRAULIC ACCESSORIES</b>	
1101989	Heating taps
1101999	Heating taps with filter
20025113	Solar diverter valve (including flexible stainless steel connection pipes)
20008794	Kit hydraulic connections (for welding)
20008795	Kit hydraulic connections (with brass nipples)
<b>SPECIAL ACCESSORIES</b>	
20012594	Lower cover (only for CIAO 20-24 C.S.I)
20012595	Upper cover (only for CIAO 20-24 C.S.I)
20164821	Frost protection resistances kit down to -10°C (only for CIAO 20-24 C.S.I)*

(\*) Together with the installation of the frost protection resistances kit (code 20164821), it is necessary to install the lower cover (code 20012594).

**HI, COMFORT CONTROLS FOR DOMESTIC COMFORT\***

CODE	DESCRIPTION
20193354	Thermostat Hi, Comfort T100 Wi-fi <sup>(1)</sup>
20193352	Thermostat Hi, Comfort T100 <sup>(2)</sup>
20193355	Wi-Fi box Hi, Comfort G100-W for internet connection via home ADSL router
20193356	RF - Wireless boiler receiver Hi, Comfort G100-R

(\*) Possibility of ON/OFF connection: for further details, refer to the pages dedicated to the Hi, Comfort Control in the THERMOREGULATION section of the Price List Catalogue.

(1) With Wi-Fi Box Hi, Comfort G100-W included for Internet connection via home ADSL Wi-Fi router.

(2) For cable connection to the boiler. Compatible for radio frequency connection with Hi, Comfort G100-W code 20193355 (accessory not included and necessary for Internet connection via home ADSL router).

**CONNECT HYBRID**

- Hydraulic separators to be matched with Exclusive C/R boilers in hybrid systems.
- Low Energy self-modulating pumps (EEI≤0,20).
- For direct zone, two direct zones, or 1 high temperature zone and 1 low temperature zone.
- Motorized mixing valve on mixed zone.
- Setting of independent climatic curves for each zone.
- To be used with control manager REC10 H.
- Limit thermostat for low temperature installations supplied as standard.
- Specifically designed only for in-wall installations (INDOOR and OUTDOOR).
- Possibility to connect the zones thermostats.

**CONNECT HYBRID - LOW ENERGY WITH MOTORIZED MIXED ZONES**

CODE	MODEL	ZONES	DIMENSIONS H x W x D (mm)
20130801	CONNECT HYBRID 1D (1) (2)	1 direct zone	see BOX
20130802	CONNECT HYBRID 2D (1) (2)	2 direct zones	see BOX
20130803	CONNECT HYBRID AT/BT (1) (3)	1AT/BT (motorized)	see BOX

(1) Supplied without built-in box (code 20130808), for the installation it is necessary to purchase it.

(2) Equipped as standard with limit thermostat for low temperature systems.

(3) Mixed zone equipped as standard with limit thermostat for low temperature systems.

**BOX FOR CONNECT**

CODE	DESCRIPTION	DIMENSIONS H x W x D (mm)
20130808	BOX for CONNECT*	720 x 400 x 160
20131752	Taps kit for Connect Hybrid	-

(\*) For the installation it is necessary to purchase built-in BOX.

CONNECT HYBRID

ACCESSORIES

CODE	DESCRIPTION
20134449	REC 10H Control manager(*)
20134478	REC 10H Power supply unit (**)

(\*) Control for hybrid systems, in accordance with the layouts provided, to be installed in EXCLUSIVE boiler. Fulfills the role of system single manager. Includes wall mounting kit in case of use as single zone manager.

(\*\*) Required if REC 10H is used as single zone manager (wall installation).

CONNECT HYBRID WITH DIRECT OR MIXED ZONES

Residual head available to the HIGH TEMPERATURE system

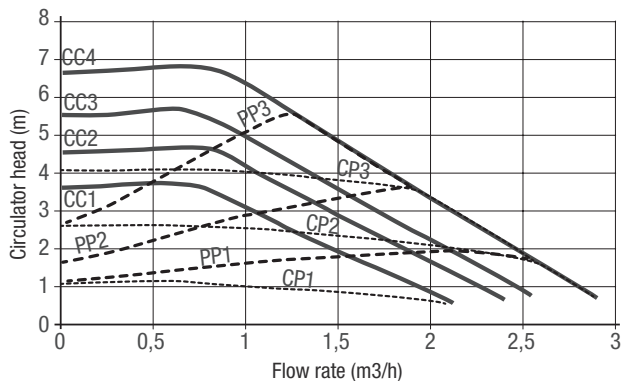

- PP1 LOW proportional head curve
- PP2 AVERAGE proportional head curve
- PP3 HIGH proportional head curve

- CP1 LOW constant head curve
- CP2 AVERAGE constant head curve
- CP3 HIGH constant head curve

Residual head available to the LOW TEMPERATURE system

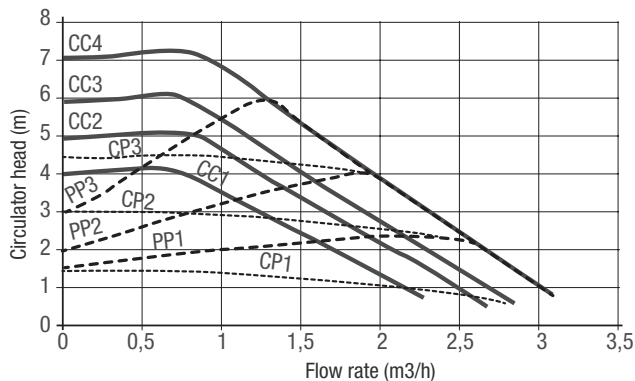

- CC1 Curve 1 = 4 metres
- CC2 Curve 2 = 5 metres
- CC3 Curve 3 = 6 metres
- CC4 Curve 4 MAX = 7 metres

**CONNECT LE**

- Can be matched with all Beretta condensing and standard-efficiency wall-hung and floor-standing boilers.
- Low Energy auto-modulating pumps (EEL≤0,20).
- Limit thermostat for low temperature installations supplied as standard.
- Specifically designed only for in-box installations (INDOOR and OUTDOOR).
- IPX4D electrical protection.
- Possibility to connect the zones thermostats.

**CONNECT LE - LOW ENERGY WITH DIRECT ZONES**

CODE	MODEL	ZONES	DIMENSIONS H x W x D (mm)
20083968	CONNECT LOW ENERGY 1D LE (*)	1 direct zone (high head)	see BOX
20083969	CONNECT LOW ENERGY 2D LE (*)	2 direct zones	see BOX
20083970	CONNECT LOW ENERGY 3D LE (*)	3 direct zones	see BOX

(\*) For the installation it is necessary to purchase the BOX (code 20007305)

**BOX FOR CONNECT**

CODE	DESCRIPTION	DIMENSIONS H x W x D (mm)
20007305	BOX for CONNECT	720 x 400 x 160

CONNECT LE

ACCESSORIES

CODE	description
20085456	Insulation kit CONNECT LE (*)
20164477	OTBus interface board for EXCLUSIVE GREEN e and EXCLUSIVE BOILER GREEN he

(\*) To be installed before introducing the CONNECT into the BOX.

CONNECT HYBRID WITH DIRECT OR MIXED ZONES

Residual head available to the system for CONNECT 1D LE

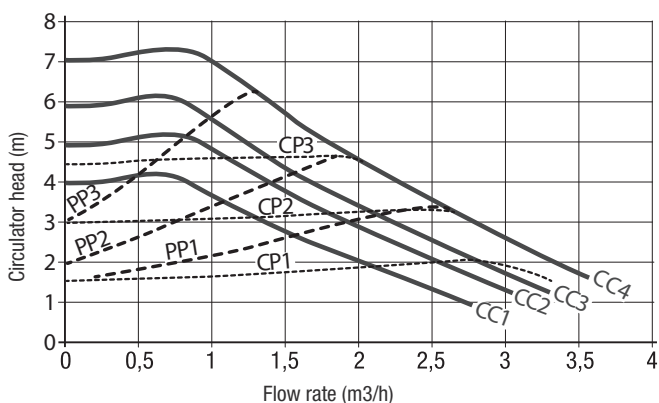

- PP1 LOW proportional head curve
- PP2 AVERAGE proportional head curve
- PP3 HIGH proportional head curve
- CP1 LOW constant head curve
- CP2 AVERAGE constant head curve
- CP3 HIGH constant head curve

Residual head available to the system for CONNECT 3D LE / CONNECT 2D LE

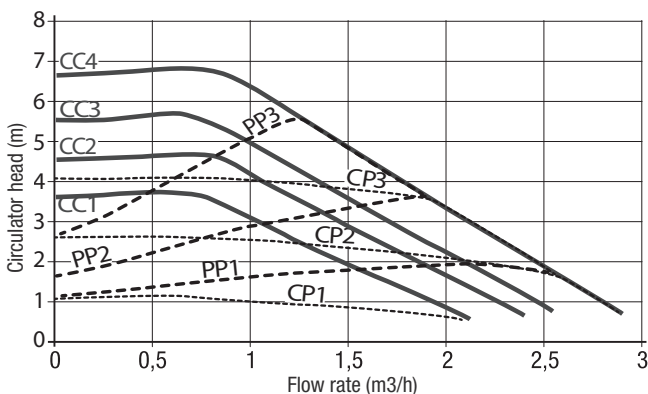

- CC1 Curve 1 = 4 metres
- CC2 Curve 2 = 5 metres
- CC3 Curve 3 = 6 metres
- CC4 Curve 4 MAX = 7 metres



## CONNECT LE

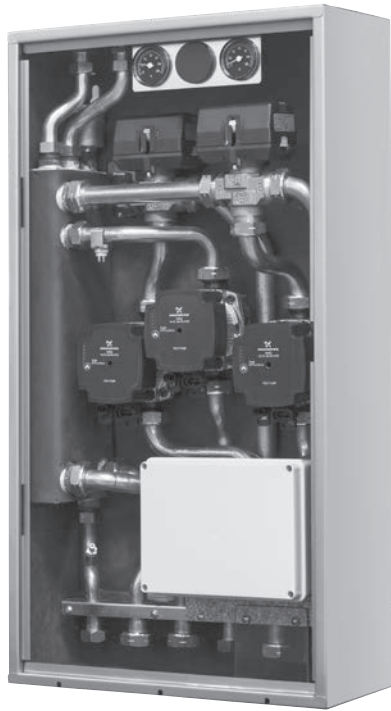

- Can be matched with all Beretta condensing and standard-efficiency wall-hung and floor-standing boilers.
- Low Energy auto-modulating pumps (EEI≤0,20).
- 3-ways motorized mixing valve.
- Independent climatic bends setting for each zone.
- Electronic management board supplied as standard.
- Limit thermostat for low temperature installations supplied as standard.
- Specifically designed only for in-box installations (INDOOR and OUTDOOR).
- IPX4D electrical protection.
- Possibility to connect the zones thermostats.

### CONNECT LE - LOW ENERGY WITH MOTORIZED MIXED ZONES

CODE	MODEL	ZONES	DIMENSIONS H x W x D (mm)
20083971	CONNECT LOW ENERGY AT/BT LE (*)	1AT+1BT	see BOX
20083972	CONNECT LOW ENERGY AT/2BT LE (*)	1AT+2BT	see BOX

(\*) For the installation it is necessary to purchase the BOX (code 20007305)

### BOX FOR CONNECT

CODE	DESCRIPTION	DIMENSIONS H x W x D (mm)
20007305	BOX for CONNECT	720 x 400 x 160

CONNECT LE

ACCESSORIES

CODE	description
20085456	Insulation kit CONNECT LE (*)
20164477	OTBus interface board for EXCLUSIVE GREEN e and EXCLUSIVE BOILER GREEN he

(\*) To be installed before introducing the CONNECT into the BOX.

CONNECT LE WITH MIXED ZONES

Residual head available at HIGH TEMPERATURE system

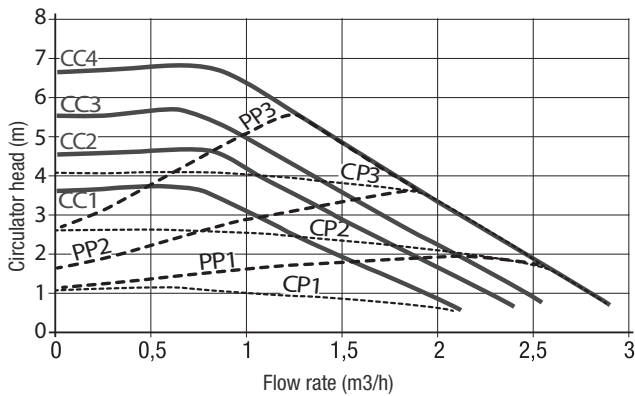

- PP1 LOW proportional head curve
- PP2 AVERAGE proportional head curve
- PP3 HIGH proportional head curve
- CP1 LOW constant head curve
- CP2 AVERAGE constant head curve
- CP3 HIGH constant head curve

Residual head available at LOW TEMPERATURE system

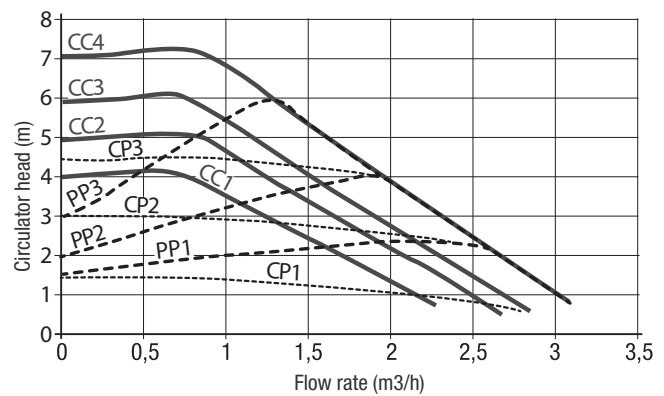

- CC1 Curve 1 = 4 metres
- CC2 Curve 2 = 5 metres
- CC3 Curve 3 = 6 metres
- CC4 Curve 4 MAX = 7 metres

**CONNECT BASE LE**

- Can be matched with all Beretta condensing and standard-efficiency wall-hung and floor-standing boilers.
- Thermostatic mixing valve on BT zones.
- Low Energy auto-modulating pumps (EEI≤0,20).
- Limit thermostat for low temperature installations supplied as standard.
- Specifically designed only for in-box installations (INDOOR and OUTDOOR).
- IPX4D electrical protection.

**CONNECT BASE LE - LOW ENERGY WITH THERMOSTATIC BT ZONES**

CODE	MODEL	DIMENSIONS H x W x D (mm)
20084765	CONNECT BASE LE MIX1 1AT+1BT (THERMOSTATIC) (*)	see BOX
20084766	CONNECT BASE LE MIX2 1AT+2BT (THERMOSTATIC) (*)	see BOX

(\*) For the installation it is necessary to purchase the BOX (code 20007305)

**BOX FOR CONNECT**

CODE	DESCRIPTION	DIMENSIONS H x W x D (mm)
20007305	BOX for CONNECT	720 x 400 x 160

# CONNECT BASE LE

## ACCESSORIES

CODE	description
20085456	Insulation kit CONNECT LE (*)

(\*) To be installed before introducing the CONNECT into the BOX.

## CONNECT BASE LE - LOW ENERGY

Residual head available at HIGH TEMPERATURE system

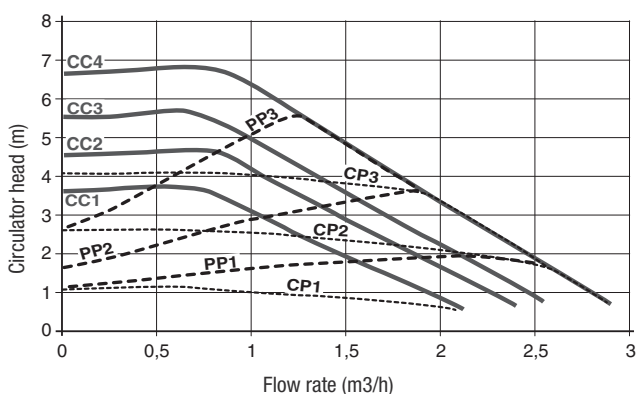





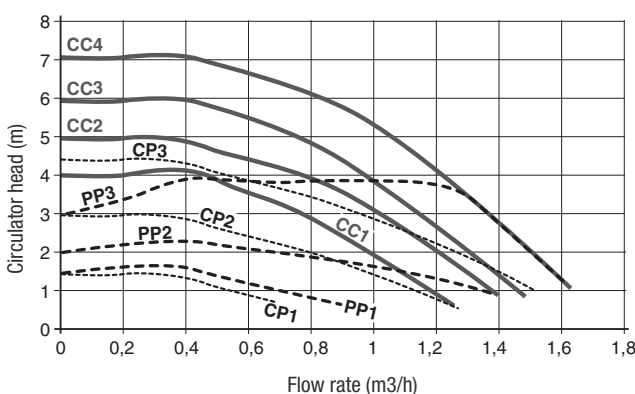



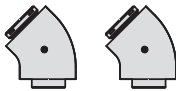

- PP1 LOW proportional head curve
- PP2 AVERAGE proportional head curve
- PP3 HIGH proportional head curve
- CP1 LOW constant head curve
- CP2 AVERAGE constant head curve
- CP3 HIGH constant head curve

Residual head available at LOW TEMPERATURE system



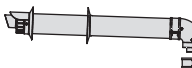
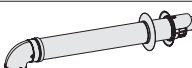
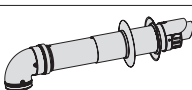

- CC1 Curve 1 = 4 metres
- CC2 Curve 2 = 5 metres
- CC3 Curve 3 = 6 metres
- CC4 Curve 4 MAX = 7 metres

**Ø60/100 CONCENTRIC FLUE SYSTEM IN PLASTIC (PP/PPU) FOR CONDENSING BOILERS - CLASS H1 (\*)**

CODE	DESCRIPTION	Exclusive EVO X - Mynute EVO X			IMAGE
		Ciao X - BLR	Meteo X		
20132012	Ø60/100 45° CONCENTRIC BEND	■	■	■	
20132040	Ø60/100 45° CONCENTRIC BEND (2 pcs.)	■	■	■	
20132013	Ø60/100 90° CONCENTRIC BEND	■	■	■	
20129172	Ø60/100 90° reduced concentric bend kit (A)	■	■	■	
20132043	Ø60/100 CONCENTRIC EXTENSION 500 mm	■	■	■	
20132044	Ø60/100 CONCENTRIC EXTENSION 1000 mm	■	■	■	
20132045	Ø60/100 CONCENTRIC EXTENSION 2000 mm	■	■	■	
20132020	Ø60/100 VERTICAL FLUE TERMINAL Ø125 EXTERNAL STRAIGHT PIPE	■	■	■	
20132018	Ø60/100 HORIZONTAL FLUE TERMINAL	■	■	■	
20129175	Ø60/100 Horizontal flue terminal kit with 90° reduced concentric bend	■	■	■	
20129176	Ø60/100 Telescopic horizontal flue terminal kit with 90° reduced concentric bend	■	■	■	
20129177	Ø60/100 Vertical flue terminal kit with vertical adapter	■	■	■	
20132050	Ø125 PITCHED ROOF TILE for VERTICAL FLUE	■	■	■	
20135579	Ø125 FLAT ROOF TILE for VERTICAL FLUE	■	■	■	
20135584	Ø100 SPACERS for PIPE (4 pcs. pack)	■	■	■	

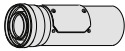
# Condensing FLUE OPTIONS

CODE	DESCRIPTION	Exclusive EVO X - Mynute EVO X			IMAGE
		Ciao X - BLR	Meteo X		
20129174	Ø60/100 Vertical adapter kit (A)	■	■	■	
20132015	Ø60/100 EXTENTION with INSPECTION DOOR	■	■	■	
20163032	Ø100 PIPE CLIPS KIT (5 pcs) (**)	■	■	■	

Due to exposition to sunlight, the colour of the material (PP) may be altered.















(\*) Class H1 - High positive pressure (max. 5,000 Pa).

(A) The straight low curve adapter codes are used to use flue Ø 60/100 available in the catalogue with Exclusive/Mynute X and Ciao AT boilers.

(\*\*) ATTENTION: For the flue options Ø60/100 concentric flue system in plastic (PP/PPU) clips are not necessary, except for the connection to the boiler. In fact clips are already included in the codes 20132020 and 20132018.

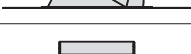
Condensing  
**FLUE OPTIONS**

**Ø80/125 CONCENTRIC FLUE SYSTEM IN PP/MET FOR CONDENSING BOILERS**



CODE	DESCRIPTION	Exclusive EVO X - Mynute EVO X			IMAGE
		Ciao X - BLR	Meteo X		
20164651	Ø80/125 45° CONCENTRIC BEND	■	■	■	
20164653	Ø80/125 90° CONCENTRIC BEND	■	■	■	
20164655	Ø80/125 90° CONCENTRIC BEND with INSPECTION DOOR	■	■	■	
20164657	Ø80/125 CONCENTRIC EXTENSION 500 mm	■	■	■	
20164659	Ø80/125 CONCENTRIC EXTENSION 1000 mm	■	■	■	
20164660	Ø80/125 CONCENTRIC EXTENSION 2000 mm	■	■	■	
20164661	Ø80/125 CONCENTRIC EXTENSION with INSPECTION DOOR	■	■	■	
20131113	Ø80/125 VERTICAL FLUE TERMINAL (in PP/PPu); Ø125 EXTERNAL STRAIGHT PIPE	■	■	■	
20164673	Ø80/125 HORIZONTAL FLUE TERMINAL (in PP/PPu)	■	■	■	
20164665	Ø80/125 SPACERS (5 pcs. pack)	■	■	■	
20132050	Ø125 PITCHED ROOF TILE FOR VERTICAL FLUE	■	■	■	
20135579	Ø125 FLAT ROOF TILE FOR VERTICAL FLUE	■	■	■	
20164666	FLUE ADAPTER from Ø60/100 to Ø80/125	■	■	■	
20164662	Ø80/125 mm concentric clapet kit for pressurized collective flues <sup>(2)</sup>	■	■	■	
20164665	Ø125 pipe spacers (5pcs)	■	■	■	

Due to exposition to sunlight, the colour of the material (PP) may be altered.

Condensing  
**FLUE OPTIONS**

Ø60 FLUE RANGE IN PLASTIC (PP) FOR INSIDE-CHIMNEY INSTALLATION, SPECIFIC FOR CONDENSING BOILERS					
CODE	DESCRIPTION				IMAGE
		Exclusive EVO X - Mynute EVO X	Ciao X - BLR	Meteo X	
20145877	Ø60 45°BEND	■	■	■	
20145876	Ø60 90°BEND	■	■	■	
20145879	Ø60 EXTENSION 500 mm	■	■	■	
20145882	Ø60 EXTENSION 1000 mm	■	■	■	
20145883	Ø60 EXTENSION 2000 mm	■	■	■	
20145884	Ø60/100 VERTICAL FLUE TERMINAL PP/PPU Ø100 EXTERNAL STRAIGHT PIPE	■	■	■	
20145894	Ø60 T-CONNECTION with CONDENSATE TRAP CAP	■	■	■	
20164584	Ø60 T-CONNECTION	■	■	■	
20145886	Ø60 3 SPACERS KIT for INSIDE-CHIMNEY	■	■	■	
20145888	SHELF SUPPORT KIT for INSIDE-CHIMNEY	■	■	■	
20145889	CHIMNEY FRONT COVER KIT	■	■	■	
20145890	Ø60 5 HOSE CLAMPS KIT	■	■	■	
20145892	Ø80-60 CHIMNEY CONNECTION KIT with Ø60 90°BEND	■	■	■	
20046782	CONDENSATE SIPHON KIT	■	■	■	

# Condensing FLUE OPTIONS

CODE	DESCRIPTION	Exclusive EVO X - Mynute EVO X			IMAGE
		Ciao X - BLR	Meteo X		
20144194	Ø60-50 FLUE ADAPTER	■	■	■	
20145897	Ø80-60 FLUE ADAPTER	■	■	■	
20163024	A T fitting Ø60 PP	■	■	■	
20163030	End cap condensate drain Ø60 PP	■	■	■	

Due to exposition to sunlight, the colour of the material (PP) may be altered.



(1) For Mynute X series connect to the boiler with codes 20129174 or 20129172 in Ø60/100 section and then use the Ø80/125 adapter 20164666.

Condensing  
**FLUE OPTIONS**

**Ø80 FLUE RANGE IN PLASTIC (PP) FOR INSIDE-CHIMNEY INSTALLATION, SPECIFIC FOR CONDENSING BOILERS**

CODE	DESCRIPTION	Exclusive EVO X - Mynute EVO X			IMAGE
		Ciao X - BLR	Meteo X		
20164570	Ø80 45°BEND	■	■	■	
20164572	Ø80 90°BEND	■	■	■	
20164574	Ø80 EXTENSION 500 mm	■	■	■	
20164577	Ø80 EXTENSION 1000 mm	■	■	■	
20164578	Ø80 EXTENSION 2000 mm	■	■	■	
20164585	Ø60/80 ADAPTER	■	■	■	
20164582	Ø60/100 CHIMNEY ADAPTER	■	■	■	
20132520	Ø80/125 CHIMNEY ADAPTER	■	■	■	
20132504	Ø80 CHIMNEY SUPPORT KIT	■	■	■	
20132505	PIPE SPACERS	■	■	■	
20132506	Ø80 INSPECTION EXTENSION	■	■	■	
20132508	Ø80 ROOF TILE	■	■	■	
20145888	SHELF SUPPORT KIT FOR CONDENSATE TRAP	■	■	■	
20145889	CHIMNEY FRONT COVER KIT	■	■	■	

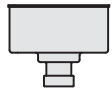
Condensing  
**FLUE OPTIONS**

CODE	DESCRIPTION	Exclusive EVO X - Mymute EVO X			IMAGE
		Ciao X - BLR	Meteo X		
20046782	CONDENSATE SIPHON KIT	■	■	■	
20163019	Ø80 CONDENSATE TRAP CAP FOR T-CONNECTION (IN ALUMINIUM)	■	■	■	
20163018	Ø80 T-CONNECTION (IN ALUMINIUM)	■	■	■	

Due to exposition to sunlight, the colour of the material (PP) may be altered.





**Ø80 TWIN FLUE SYSTEM IN ALUMINIUM FOR STANDARD-EFFICIENCY BOILERS AND WATER-HEATERS**

CODE	DESCRIPTION									IMAGE
		Exclusive MIX C.S.I./R.S.I.	Mynute S 24-28 C.S.I./R.S.I.	Mynute S 35 C.S.I./R.S.I.	Ciao S C.S.I./R.S.I.	City C.S.I./R.S.I.	Quadra II C.S.I.	Ciao 28 C.S.I. e	Ciao 16-20-24 C.S.I.	
20162668	Ø80 TWIN SYSTEM KIT				■	■	■			
20162667	Ø80 TWIN SYSTEM KIT	■	■					■	■	
20162666	FLUE ADAPTER KIT from Ø60/100 to Ø80/80	■	■	■	■	■	■	■	■	
20162665	Ø80 AIR INLET HORIZONTAL TERMINAL	■	■	■	■	■	■	■	■	
20162664	Ø80 HORIZONTAL FLUE TERMINAL	■	■	■	■	■	■	■	■	
20162295	Ø80 90° BEND WITH GASKET	■	■	■	■	■	■	■	■	
20162296	Ø80 45° BEND WITH GASKET	■	■	■	■	■	■	■	■	
20162455	FLUE ADAPTER Ø60/100 TO Ø80 FOR B23/B22 INSTALLATION WITH AIR INLET		■		■	■	■			
20162298	Ø80 EXTENSION (500 mm) with GASKET	■	■	■	■	■	■	■	■	
20162299	Ø80 EXTENSION (1000 mm) with GASKET	■	■	■	■	■	■	■	■	
20162300	Ø80 EXTENSION (1950 mm) with GASKET	■	■	■	■	■	■	■	■	
20162835	Ø80 AIR REGULATION FLANGE KIT	■	■	■	■	■	■	■	■	
20162662	Ø80 CONDENSATE TRAP HORIZONTAL	■	■	■	■	■	■	■	■	
20162663	Ø80 CONDENSATE TRAP VERTICAL	■	■	■	■	■	■	■	■	
20137532	Ø80 SPACERS FOR PIPE (4 pcs. pack)	■	■	■	■	■	■	■	■	

**Ø60/100 CONCENTRIC FLUE SYSTEM IN AL/MET FOR STANDARD-EFFICIENCY BOILERS AND WATER-HEATERS**

CODE	DESCRIPTION									IMAGE
		Exclusive MIX C.S.I./R.S.I.	Mynute S 24-28 C.S.I./R.S.I.	Mynute S 35 C.S.I./R.S.I.	Ciao S C.S.I./R.S.I.	City C.S.I./R.S.I.	Quadra II C.S.I.	Ciao 28 C.S.I. e	Ciao 16-20-24 C.S.I.	
20163422	Ø60/100 VERTICAL TERMINAL; Ø125 EXTERNAL STRAIGHT PIPE	■	■	■	■	■	■	■	■	
20163408	Ø60/100 HORIZONTAL TERMINAL	■	■	■	■	■	■	■	■	
20163410	Ø60/100 TELESCOPIC HORIZONTAL TERMINAL EXTENSIBLE FROM 500 TO 800 mm	■	■	■	■	■	■	■	■	
20163391	Ø60/100 CONCENTRIC EXTENSION (750 mm)	■	■	■	■	■	■	■	■	
20163393	Ø60/100 CONCENTRIC EXTENSION (1470 mm)	■	■	■	■	■	■	■	■	
20163388	Ø60/100 90° ADAPTER BEND KIT for REPLACEMENT*				■	■	■			
20163333	Ø60/100 90° CONCENTRIC BEND	■	■	■	■	■	■	■	■	
20163327	Ø60/100 45° CONCENTRIC BEND	■	■	■	■	■	■	■	■	
20163429	Ø100 CONNECTION CLIP KIT H 80 mm (4 pcs.)	■	■	■	■	■	■	■	■	
20163425	Ø60/100 CONNECTION CLIP KIT BOILER-FLUE	■	■	■	■	■	■	■	■	
20132050	Ø125 PITCHED ROOF TILE FOR VERTICAL FLUE	■	■	■	■	■	■	■	■	
20135579	Ø125 FLAT ROOF TILE FOR VERTICAL FLUE	■	■	■	■	■	■	■	■	
20163400	Ø60/100 CONDENSATE TRAP HORIZONTAL	■	■	■	■	■	■	■	■	
20163403	Ø60/100 CONDENSATE TRAP VERTICAL	■	■	■	■	■	■	■	■	

Standard-efficiency  
**FLUE OPTIONS**

CODE	DESCRIPTION									IMAGE
		Exclusive MIX C.S.I./R.S.I.	Mynute S 24-28 C.S.I./R.S.I.	Mynute S 35 C.S.I./R.S.I.	Ciao S C.S.I./R.S.I.	City C.S.I./R.S.I.	Quadra II C.S.I.	Ciao 28 C.S.I. e	Ciao 16-20-24 C.S.I.	
20135584	Ø100 SPACERS FOR PIPE (4 pcs. pack)	■	■	■	■	■	■	■	■	
20163430	Ø14 FLANGED SOCKET FOR INSPECTION FOR CONCENTRIC PIPE (2 pcs.)	■	■	■	■	■	■	■	■	

(\*) To be used in case of replacement of old Mynute 24 C.S.I with CIAO S range and with CIAO 24 C.S.I. E, only in case of concentric flue through wall.

HYBRID SYSTEMS

HEAT PUMPS

WALL HUNG BOILERS

WATER-HEATERS

SOLAR THERMAL UNIT AND CYLINDERS









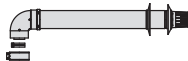

CENTRALIZED HEATING

AIR CONDITIONING











TERMINAL UNITS

SYSTEM COMPLEMENTARY ITEMS

**Ø60/100 CONCENTRIC FLUE SYSTEM IN AL/PPU FOR STANDARD-EFFICIENCY BOILERS AND WATER-HEATERS**

CODE	DESCRIPTION									IMAGE
		Exclusive MIX C.S.I./R.S.I.	Mynute S 24-28 C.S.I./R.S.I.	Mynute S 35 C.S.I./R.S.I.	Ciao S C.S.I./R.S.I.	City C.S.I./R.S.I.	Quadra II	Ciao 28 C.S.I.e	Ciao 16-20-24 C.S.I.	
20162797	Ø60/100 VERTICAL FLUE TERMINAL; Ø125 EXTERNAL STRAIGHT PIPE	■	■	■	■	■	■	■	■	
20162798	Ø60/100 CONCENTRIC HORIZONTAL TERMINAL	■	■	■	■	■	■	■	■	
20162799	Ø60/100 TELESCOPIC HORIZONTAL TERMINAL EXTENSIBLE FROM 500 mm TO 800 mm	■	■	■	■	■	■	■	■	
20162793	Ø60/100 CONCENTRIC EXTENSION 500 mm	■	■	■	■	■	■	■	■	
20162795	Ø60/100 CONCENTRIC EXTENSION 1000 mm	■	■	■	■	■	■	■	■	
20162796	Ø60/100 CONCENTRIC EXTENSION 2000 mm	■	■	■	■	■	■	■	■	
20162786	Ø60/100 90° CONCENTRIC BEND	■	■	■	■	■	■	■	■	
20162785	Ø60/100 45° CONCENTRIC BEND	■	■	■	■	■	■	■	■	
20162790	Ø60/100 90° CONCENTRIC BEND WITH INSPECTION DOOR	■	■	■	■	■	■	■	■	
20132050	Ø125 PITCHED ROOF TILE FOR VERTICAL FLUE	■	■	■	■	■	■	■	■	
20135579	Ø125 FLAT ROOF TILE FOR VERTICAL FLUE	■	■	■	■	■	■	■	■	
20135584	Ø100 SPACERS FOR PIPE (4 pcs. pack)	■	■	■	■	■	■	■	■	

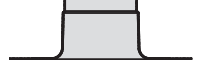
**Ø80/125 CONCENTRIC FLUE SYSTEM IN AL/MET FOR STANDARD-EFFICIENCY BOILERS**

CODE	DESCRIPTION									IMAGE
		Exclusive MIX C.S.I./R.S.I.	Mynute S 24-28 C.S.I./R.S.I.	Mynute S 35 C.S.I./R.S.I.	Ciao S C.S.I./R.S.I.	City C.S.I./R.S.I.	Quadra II	Ciao 28 C.S.I. e	Ciao 16-20-24 C.S.I.	
20164216	FLUE ADAPTER FROM Ø60/100 TO Ø80/125 WITH FLUE ANALYSIS POINT	■	■	■	■	■	■	■	■	
20164202	Ø80/125 45° CONCENTRIC BEND	■	■	■	■	■	■	■	■	
20164206	Ø80/125 90° CONCENTRIC BEND	■	■	■	■	■	■	■	■	
20164213	Ø80/125 HORIZONTAL TERMINAL WITH Ø60/100 ADAPTER	■	■	■	■	■	■	■	■	
20164215	Ø80/125 VERTICAL TERMINAL WITH Ø60/100 ADAPTER	■	■	■	■	■	■	■	■	
20164207	Ø80/125 CONCENTRIC EXTENSION 500 mm	■	■	■	■	■	■	■	■	
20164208	Ø80/125 CONCENTRIC EXTENSION 1000 mm	■	■	■	■	■	■	■	■	
20164211	Ø80/125 CONCENTRIC EXTENSION 2000 mm	■	■	■	■	■	■	■	■	
20164217	SIPHON FOR VERTICAL ADAPTER	■	■	■	■	■	■	■	■	
20135579	Ø125 FLAT ROOF TILE FOR VERTICAL FLUE	■	■	■	■	■	■	■	■	
20132050	Ø125 PITCHED ROOF TILE FOR VERTICAL FLUE	■	■	■	■	■	■	■	■	
20164665	Ø80/125 SPACERS (5 pcs.)	■	■	■	■	■	■	■	■	



**Ø80 TWIN FLUE SYSTEM IN PLASTIC (PP) FOR CONDENSING BOILERS - H1 CLASS (\*)**

CODE	DESCRIPTION	Exclusive EVO X - Mynute EVO X			IMAGE
		Ciao X - BLR	Meteo X		
20134830	Flue adapter kit from Ø60/100 to twin Ø80-80 swelling position	■	■	■	
20190475	Compact adjustable splitter device kit from Ø60/100 mm to Ø80/80 mm	■	■	■	
20129765	Flue adapter kit from Ø60/100 to twin Ø80-80	■	■	■	
20217921	Split connection system kit Ø80 mm	■			
20137503	Ø80 45°bend	■	■	■	
20137506	Ø80 90°bend	■	■	■	
20137508	Ø80 extension 500 mm	■	■	■	
20137509	Ø80 extension 1000 mm	■	■	■	
20137511	Ø80 extension 2000 mm	■	■	■	
20137517	Ø80 horizontal flue terminal 985 mm	■	■	■	
20137515	Ø80 air inlet horizontal terminal 662 mm	■	■	■	
20129769	Flue adapter from Ø60/100 to Ø80 for B23 installation with air inlet	■	■	■	
20129768	Ø60-80 flue adapter for installation type B23 and air inlet	■	■	■	
20137532	Ø80 spacers for pipe (4 pcs. Pack)	■	■	■	
20164664	Split connection system kit Ø80 mm <sup>(3)</sup>	■	■	■	

Due to exposition to sunlight, the colour of the material (PP) may be altered.  
(\*) Class H1 - High positive pressure (max. 5,000 Pa).



WATER-HEATERS



HEAT PUMPS	168
LOW NOX INSTANTANEOUS - GAS	172
FLUE OPTION SYSTEMS	175



## DHW wall-hung heat pumps ACQUAZENIT



- Heat pump for domestic hot water production, wall mounted.
- Heat pump operating air temp. from -7°C to 35°C (ACQUAZENIT E 80 – E 120).
- Heat pump operating air temp. from +7°C to 35°C (ACQUAZENIT 80 – 120).
- Combination of heat pump and back up electric heating (electric heater included).
- Rotation compressor on heat pump side.
- Heat pump condenser wraps around DHW tank.
- Legionella control function.
- Built-in enamelled DHW tank with magnesium anode.
- High insulation grade of the tank for low heat losses.
- Easy and fast installation.
- DHW temperature production up to 75°C.
- TURBO mode for fast hot water production.
- Diagnostic, alarms and hot water storage information.
- Large display with touch screen.
- Advanced electronic control with timing, temperatures and operating mode selection.



### WALL-HUNG DHW HEAT PUMPS

CODE	DESCRIPTION	DIMENSIONS H X L X D (mm)	HEATING CAPACITY (kW)	C.O.P. (50°) <sup>(1)</sup>	CLASS
					(F→A+)*
20075566	ACQUAZENIT 80	1197 x 506 x 533	2.35	3.10	A+
20075568	ACQUAZENIT 120	1497 x 506 x 533	2.35	3.10	A+
20075569	ACQUAZENIT E 80	1197 x 506 x 533	2.35	3.10	A+
20075571	ACQUAZENIT E 120	1497 x 506 x 533	2.35	3.10	A+

(\*) The range of energy efficiency class of this products category is between F and A+

(1) Tair 15°C; Twater 10-55°C (EN 16147)

Note: Before installation, check the compatibility of weight and dimensions with the room and with the fixing system.

# DHW wall-hung heat pumps

## ACQUAZENIT

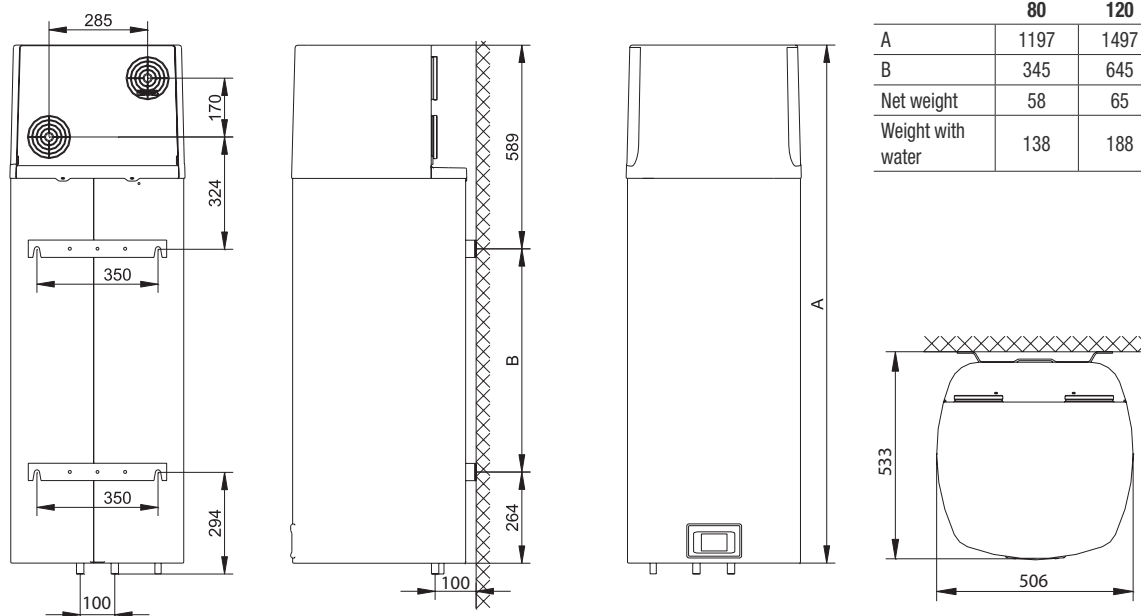

### TECHNICAL SPECIFICATIONS

DESCRIPTION		80	E80	120	E120
Tank capacity	l	80		120	
Rated pressure	bar	6.00			
Anti-corrosion protection of tank		enamelled / Magnesium anode			
Insulation thickness	mm	40 - 85			
Degree of protection		IP 24			
Max absorbed power	W	2350			
Power supply	V-Hz	230-50			
Number and electric heaters capacity	W	2 X 1000			
Electrical protection	A	16			
Water temperature set	°C	55			
Max water temperature (HP / electric heater)	°C	55 / 75			
Legionella control cycle	°C	70			
Air operating limits	°C	7	-7	7	-7
Refrigerant type		R134a			
Refrigerant charge	g	490	540	490	540
Heating time <sup>(1)</sup>	h:min	4:40		6:40	
Energy consumption during heating <sup>(1)</sup>	kW	0.99		1.41	
Type of measured cycle of emissions		M			
Energy consumption in the selected cycle of emissions <sup>(1)</sup>	kW	2.04		2.08	
COPDHW in the selected cycle of emissions <sup>(1)</sup>		3.10			
Heating time <sup>(2)</sup>	h:min	5:20		8:41	
Energy consumption during heating <sup>(2)</sup>	kW	1.12		1.78	
Energy consumption in the selected cycle emissions <sup>(2)</sup>	kW	2.45		2.51	
COPDHW in the selected cycle of emissions <sup>(2)</sup>		2.65		2.61	
Max available water (40 °C)	l	90		142	
Power INPUT in standby mode (according to EN16147)	W	19		27	
Sound power	dB <sup>(A)</sup>	51			
Sound pressure at 1m	dB <sup>(A)</sup>	39.5			
Air Flow	m <sup>3</sup> /h	100 - 230			
Max available pressure drop in the pipeline (volumetric flow rate of air 100 m <sup>3</sup> /h)	Pa	95			

(1) Tair 15 °C; Twater 10 - 55°C (EN 16147)

(2) Tair 7 °C; Twater 10 - 55°C (EN 16147)



DHW floor-standing heat pumps

## HP-N ACS - FLOOR STANDING DOMESTIC HOT WATER HEAT PUMPS



- Air-to-water heat pump for DHW production
- Available in the version with only heat pump (180 lt- 250lt) and heat pump with an auxiliary coil (250lt)
- HP-N 250 ACS S combinable with an additional heating source (solar system or gas boiler)
- Condenser externally wrapped to the boiler free from fouling and gas-water contamination.
- Tanks of 180 and 250 liters in enameled steel
- Standard time programmer
- Boost function (in combination with an electric resistance)
- External cladding in painted sheet metal
- Carrying handles available as accessory
- Cylinders with magnesium anode.
- Electrical resistance of 1,5kW provided as standard (for versions without coil)
- Working range: -5°C to +35°C.
- Maximum DHW temperature 62°C
- R1234-ze refrigerant charger.

### DHW FLOOR-STANDING HEAT PUMPS

CODE	DESCRIPTION	DIMENSIONS H x Ø (mm)	HEATING CAPACITY (1) (kW)	C.O.P.(1)(3)	Recovery time (2)(3)	HEATING CAPACITY (2) (kW)	C.O.P.(2)(3)	CLASS
								(F→A+)*
<b>HEAT WATER IN HEAT PUMP</b>								
20217268	HP-N 180 ACS	1555 x 584	1,23	2,92	08:04	1,42	3,39	A+
20217270	HP-N 250 ACS	1755 x 631	1,17	3,23	10:12	1,73	3,7	A+
<b>HEAT WATER IN HEAT PUMP + SECONDARY SOURCE</b>								
20217272	HP-N 250 ACS S	1755 x 631	1,17	3,22	09:07	1,73	3,7	A+

(\*) DHW: the energy efficiency class of the products ranges from F up to A+  
The performance refers to the following conditions.

(1) Performance data for operation with external air according to EN 16147:2017 for A7/W10-53 (air inlet temperature 7 °C/ambient temperature 20 °C).

(2) Performance data for operation with recirculated air and operation with recirculated air with air outlet to the outside according to EN 16147:2017 for A20/W10-53 (air inlet temperature 20 °C/ambient temperature 20 °C).

(3) Load profile L.

### ACCESSORIES

CODE	DESCRIPTION
20219436	Flange for electrical heater for HP-N 250 ACS S
20219032	Electrical heater 1,5kw for HP-N 250 ACS S
20219952	2 outside air adapters (in-out air)(DN 160) for HP-N 180 ACS

CODE	DESCRIPTION
20219018	2 outside air adapters (in-out air)(DN 160) for HP-N 250 ACS - ACS S
20219021	Smart Grid connection set
20219027	Electronic anode
20219029	Carrying handles
20219031	Hydraulic connections for solar systems

**NOTE:** For the safety of the system, always include a safety valve, a check valve, and an expansion vessel for domestic water in the installation.  
Accessories will be available in November

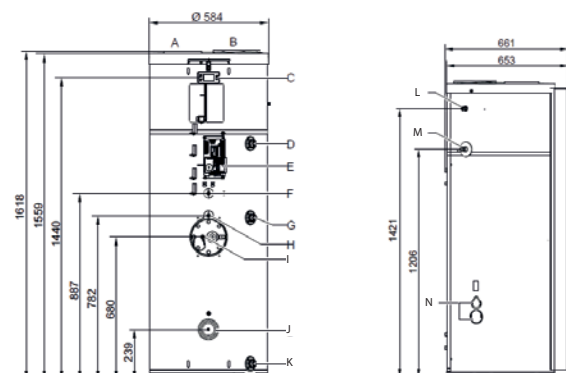
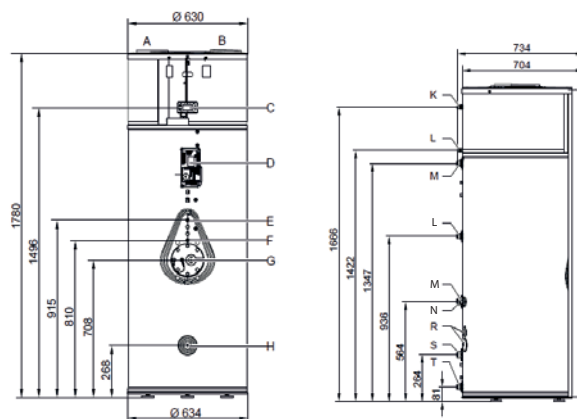
**HP-N 180 ACS**

**HP-N 250 ACS - HP-N 250 ACS S**

- (A) Air discharge
  - With grille: For recirculation air mode
  - With DN 160 outdoor air adaptor: For recirculation air mode with air discharge to the outside and outdoor air mode
- (B) Air intake
  - With grille: For recirculation air mode
  - With DN 160 outdoor air adaptor: For recirculation air mode with air discharge to the outside and outdoor air mode
- (C) Programming unit.
- (D) DHW R ¾.
- (E) Heat pump control unit.
- (F) Sensor well for draw-off profile M.
- (G) DHW circulation R ¾.
- (H) Sensor well for draw-off profile L.
- (I) Factory-fitted temperature sensors:
  - Cylinder temperature sensor and High limit safety cutout for DHW heat pump.
  - Inspection port.
  - Protective magnesium anode.
  - Impressed current anode (accessories).
  - EHT electrical heating element (supply status).
- (J) Sensor well for draw-off profile recognition.
- (K) Cold water/drain R ¾.
- (L) Power cable (length 3 m).
- (M) Condensate outlet 7 20 mm.
- (N) Injection process plug (do not open, do not insert anything).

## TECHNICAL SPECIFICATIONS\*

		HP-N 180 ACS	HP-N 250 ACS	HP-N 250 ACS S
Tank capacity	l	178	254	246
Coil surface	m <sup>2</sup>	-	-	1
Dispersion in stand-by (Pes)	W/K	29	23	23
Max working pressure tank	bar	8	8	8
Max water temperature	°C	65	65	65
Electrical power input of EHT electrical heating element	W	1500	1500	1500
Refrigerant type	tipo	R1234-ze	R1234-ze	R1234-ze
Refrigerant charge	kg	1,15	1,35	1,25
Noise level	dB(A)	41	38	38
C.O.P. dhw		2,92	3,23	3,23
Max. volumetric flow rate of freely expelled air (2 speed)	m <sup>3</sup> /h	320	375	375
Connections (male thread) Cold water, hot water	R	3/4	3/4	3/4
Connections (male thread) DHW recirculation	R	3/4	3/4	3/4
External heat generator/solar collector delivery/return	G	-	-	1
Condensate outlet (Ø)	mm	20	20	20
Net weight	kg	95	110	125

(\*) For more information refer to the dedicated technical documentation.



- Instantaneous open chamber gas water heater
- 11 and 14-liter, NG and LPG models with dedicated codes
- Automatic battery ignition (2 x 1,5V batteries supplied as standard) with water control
- Proportional flame modulation to adapt gas consumption to domestic hot water withdrawal
- Reduced NOx emissions: class 6 (UNI EN 15502)
- User interface with mechanical adjustment via knobs and backlit display for temperature visualization
- Pressure regulator as standard
- Increased load profile (XL) on 14-liter models

INTERAXES AND HYDRAULIC FITTINGS POSITIONING

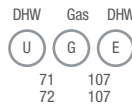

## CONVENTIONAL FLUE

CODE	MODEL	GAS	DIMENSIONS <sup>(1)</sup> H x W x D (mm)	OUTPUT (kW)	DHW PRODUCTION (l/min. - Δt 30 °C)	CLASS	
						(F→A+)*	
<b>IONISATION FLAME - BATTERY IGNITION</b>							
20213288	FONTE Lx 11 P LPG	LPG	636 x 350 x 225	18,5	8,4	A	M**
20213229	FONTE Lx 11 P MTN	MTN	636 x 350 x 225	18,5	8,8	A	M**
20213231	FONTE Lx 14 P LPG	LPG	696 x 370 x 225	23,2	11,1	A	XL**
20213233	FONTE Lx 14 P MTN	MTN	696 x 370 x 225	23,7	11,3	A	XL**

(\*) DHW: the energy efficiency class of the products ranges from F up to A+

(\*\*) Load profile.

(1) Dimensions without flues.



# Instantaneous gas water-heaters

## IDRABAGNO LX



- Gas water heaters for indoor installation.
- Low Nox range according to EN 814-2013.  
Low Nox value < 56 mg/kWh, via cooled burner.
- Air-gas combustion, with 3:1 modulation ratio.
- A wide range of models of 11, 13 and 17 lt, available both as NG and LPG versions.
- New back-lit display with icons, 40x30 mm, with four push-buttons.
- New electronics with innovative performance.
- New aesthetics lines, in accordance with the wall-hung boilers style.
- Frost protection kit for outdoor installation with resistance (down to -10°C).
- Ø60 and Ø80 air-inlet for the models 11 and 13 lt.
- Ø60/100 flue exit.

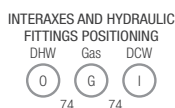

### ROOM-SEALED

CODE	MODEL	GAS	DIMENSIONS H x W x D (mm)	OUTPUT (kW)	DHW PRODUCTION (l/min. - Δt 30 °C)	CLASS	
						(F→A+)*	
<b>IONISATION FLAME - ELECTRONIC IGNITION</b>							
20143031	IDRABAGNO Lx 11	NG	642 x 340 x 237	19,89	9,5	A	M**
20143032	IDRABAGNO Lx 11	LPG	642 x 340 x 237	19,89	9,5	A	M**
20143035	IDRABAGNO Lx 13	NG	642 x 340 x 237	22,45	10,7	A	L**
20143036	IDRABAGNO Lx 13	LPG	642 x 340 x 237	22,45	10,7	A	L**
20143037	IDRABAGNO Lx 17	NG	640 x 400 x 246	27,60	13,2	A	XL**
20143038	IDRABAGNO Lx 17	LPG	640 x 400 x 246	27,60	13,2	A	XL**

(\*) DHW: the energy efficiency class of the products ranges from F up to A+

(\*\*) Load profile.

**ACCESSORIES**



CODE	DESCRIPTION
<b>SPECIFIC ACCESSORIES</b>	
1100499	Hydraulic taps
1100509	Gas tap 3/4" right-angle
20148036	Frost protection resistances kit
20162668	Ø80 twin system kit (for 11-13 models)
20162667	Ø80 twin system kit (for 17 model)
20162666	Flue adapter kit from Ø60/100 to Ø80-80
20122792	Ø60/100 Adapter bend kit for replacement (for 11-13 model)
20162798	Ø60/100 concentric horizontal terminal
20155911	Dummy for Idrabagno Lx 11
20155581	LPG gas transformation kit for Idrabagno Lx 11
20155583	LPG gas transformation kit for Idrabagno Lx 13
20157837	LPG gas transformation kit for Idrabagno Lx 17

Note: For the installation of IDRABAGNO Lx under low temperature conditions (down to -10°C), it is available the frost protection kit (code 20148036).









## FLUE OPTION FOR STANDARD EFFICIENCY

Ø80 TWIN FLUE SYSTEM IN ALUMINIUM FOR STANDARD-EFFICIENCY BOILERS AND WATER-HEATERS				
CODE	DESCRIPTION			IMAGE
		Idrabagno Lx 11-13	Idrabagno Lx 17	
20162668	Ø80 TWIN SYSTEM KIT	■		
20162667	Ø80 TWIN SYSTEM KIT		■	
20162666	FLUE ADAPTER KIT from Ø60/100 to Ø80-80	■	■	
20162665	Ø80 AIR INLET HORIZONTAL TERMINAL	■	■	
20162664	Ø80 HORIZONTAL FLUE TERMINAL	■	■	
20162295	Ø80 90° BEND WITH GASKET	■	■	
20162296	Ø80 45° BEND WITH GASKET	■	■	
20162298	Ø80 EXTENSION (500 mm) with GASKET	■	■	
20162299	Ø80 EXTENSION (1000 mm) with GASKET	■	■	
20162300	Ø80 EXTENSION (1950 mm) with GASKET	■	■	

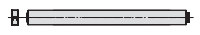

## FLUE OPTION FOR STANDARD EFFICIENCY

CODE	DESCRIPTION	Idrabagno Lx 11-13	Idrabagno Lx 17	IMAGE
20162835	Ø80 AIR REGULATION FLANGE KIT	■	■	
20137532	Ø80 SPACERS FOR PIPE (4 pcs. pack)	■	■	

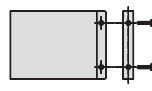
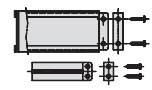
## FLUE OPTION FOR STANDARD EFFICIENCY

<b>Ø60/100 CONCENTRIC FLUE SYSTEM IN AL/MET FOR STANDARD-EFFICIENCY BOILERS AND WATER-HEATERS</b>			
CODE	DESCRIPTION	I drabagno Lx 11-13	IMAGE
20163422	Ø60/100 VERTICAL TERMINAL; Ø125 EXTERNAL STRAIGHT PIPE	■	
20163408	Ø60/100 HORIZONTAL TERMINAL	■	
20163410	Ø60/100 TELESCOPIC HORIZONTAL TERMINAL EXTENSIBLE FROM 500 TO 800 mm	■	
20163391	Ø60/100 CONCENTRIC EXTENSION (750 mm)	■	
20163393	Ø60/100 CONCENTRIC EXTENSION (1470 mm)	■	
20122792	Ø60/100 90° adapter bend kit for REPLACEMENT *	■	
20163333	Ø60/100 90° CONCENTRIC BEND	■	
20163327	Ø60/100 45° CONCENTRIC BEND	■	
20163429	Ø100 CONNECTION CLIP KIT H 80 mm (4 pcs.)	■	
20163425	Ø60/100 CONNECTION CLIP KIT BOILER-FLUE	■	

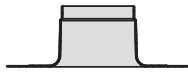
## FLUE OPTION FOR STANDARD EFFICIENCY

CODE	DESCRIPTION	Idrabagno Lx 11-13	IMAGE
20132050	Ø125 PITCHED ROOF TILE FOR VERTICAL FLUE	■	
20135579	Ø125 FLAT ROOF TILE FOR VERTICAL FLUE	■	
20135584	Ø100 SPACERS FOR PIPE (4 pcs. pack)	■	
20163430	Ø14 FLANGED SOCKET FOR INSPECTION FOR CONCENTRIC PIPE (2 pcs.)	■	

\* To be used in case of replacement of water heaters Idrabagno 11 and 13 ESI, in case of rear flues.

## FLUE OPTION FOR STANDARD EFFICIENCY

HYBRID SYSTEMS

HEAT PUMPS

WALL HUNG BOILERS

WATER-HEATERS







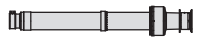

 SOLAR THERMAL UNIT  
AND CYLINDERS

 CENTRALIZED  
HEATING



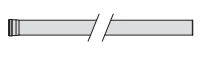

AIR CONDITIONING

TERMINAL UNITS

 SYSTEM  
COMPLEMENTARY ITEMS

<b>Ø60/100 CONCENTRIC FLUE SYSTEM IN AL/PPU FOR STANDARD-EFFICIENCY BOILERS AND WATER-HEATERS</b>			
CODE	DESCRIPTION	Idragnano Lx 11-13	IMAGE
20162797	Ø60/100 VERTICAL FLUE TERMINAL; Ø125 EXTERNAL STRAIGHT PIPE	■	
20162798	Ø60/100 CONCENTRIC HORIZONTAL TERMINAL	■	
20162799	Ø60/100 TELESCOPIC HORIZONTAL TERMINAL EXTENSIBLE FROM 500 mm TO 800 mm	■	
20162793	Ø60/100 CONCENTRIC EXTENSION 500 mm	■	
20162795	Ø60/100 CONCENTRIC EXTENSION 1000 mm	■	
20162796	Ø60/100 CONCENTRIC EXTENSION 2000 mm	■	
20162786	Ø60/100 90° CONCENTRIC BEND	■	
20162785	Ø60/100 45° CONCENTRIC BEND	■	
20066967	Ø60/100 90° CONCENTRIC BEND - FOR BOILER CONNECTION	■	
20162790	Ø60/100 90° CONCENTRIC BEND WITH INSPECTION DOOR	■	

## FLUE OPTION FOR STANDARD EFFICIENCY

CODE	DESCRIPTION	Idrabagno Lx 11-13	IMAGE
20066969	Ø60/100 90° CONCENTRIC BEND WITH INSPECTION DOOR - FOR BOILER CONNECTION	■	
20124577	Ø100 CONNECTION CLIP KIT (5 pcs)	■	
20132050	Ø125 PITCHED ROOF TILE FOR VERTICAL FLUE	■	
20135579	Ø125 FLAT ROOF TILE FOR VERTICAL FLUE	■	
20135584	Ø100 SPACERS FOR PIPE (4 pcs. pack)	■	



SOLAR THERMAL  
AND CYLINDERS



SOLAR SYSTEMS	184
SOLAR COLLECTORS	198
SOLAR DHW AND STORAGE CYLINDERS	206
COMPLEMENTARY ITEMS	229



- (A) SCF-25/4B A sealed collector with prepainted galvanized steel profile - 2.5 sq.m
- (B) IDRA DS FI (200 lt, 300 lt, 430 lt) double coil cylinder with pre-installed flow/return hydraulic group, featuring a Low Energy modulating circulator, and EVOSOL control box
- (C) Glycol
- (D) Solar expansion vessel 3/4"
- (E) Thermostatic mixing valve
- (F) Hydraulic panel fittings for SCF 25/4 A systems



SOLAR KEYMARK  
certification

**SYSTEMS FOR FLAT AND PITCHED ROOF - BRACKETS NOT INCLUDED**

CODE	MODEL	NUMBER OF COLLECTORS	CYLINDER CAPACITY (l)	COLLECTORS DIMENSIONS H x W (mm)	COLLECTORS TOTAL AREA (m <sup>2</sup> )
<b>SYSTEMS WITH DOUBLE-COIL HEATER</b>					
20207663	SCF-25/4B A 200/1	1	208 double coil <sup>(1)</sup>	2004 x 1195	2,5
20207664	SCF-25/4B A 300/2	2	301 double coil <sup>(1)</sup>	2004 x 2390	5
20207657	SCF-25/4B A 400/3	3	430 double coil <sup>(1)</sup>	2004 x 3585	7,5

(1) Double-coil heater with hydraulic unit complete with M/R hydraulic unit.

To complete the installation it is necessary to purchase the complete bracket kits, choosing them according to the number of collectors, from slanting roof bracket kit, undertile roof bracket kit for slanting roof and flat roof bracket kit.

**ACCESSORIES**

CODE	MODEL
<b>ACCESSORIES FOR FLAT ROOF (FR 30-45°)</b>	
20201443	Brackets 1 solar collector 2,5m <sup>2</sup> "A" FR 30-45°
20201444	Extension brackets for 1 additional solar collector 2,5m <sup>2</sup> "A" FR 30-45°
<b>ACCESSORIES FOR PITCHED ROOF (PR)</b>	
20201446	Brackets 1 solar collector 2-2,5m <sup>2</sup> "A" undertile PR
20201447	Brackets 2 solar collectors 2-2,5m <sup>2</sup> "A" undertile PR
20201611	Extension brackets for 1 additional solar collector 2-2,5m <sup>2</sup> "A" undertile PR <sup>(1)</sup>
20201445	Kit 4 brackets hooks for PR - "A" solar collector
20202639	Kit 6 brackets hooks for PR - "A" solar collector
<b>HYDRAULIC KIT FOR SOLAR COLLECTOR "A"</b>	
20201448	Hydraulic kit for 1 "A" solar collector
20201449	Hydraulic kit for 2 "A" solar collectors
20201450	Hydraulic kit for 3 "A" solar collectors
20201451	Hydraulic kit for 4 "A" solar collectors
20201453	Hydraulic kit for 5 "A" solar collectors
20201454	Hydraulic kit for 6 "A" solar collectors
20201455	Hydraulic kit for 7 "A" solar collectors
20201457	Hydraulic kit for 8 "A" solar collectors
20201458	Hydraulic kit for 9 "A" solar collectors
20201459	Hydraulic kit for 10 "A" solar collectors

(1) Add this extension brackets only to the code 20201447 (Brackets 2 solar collectors 2-2,5m<sup>2</sup> "A" undertile PR)

Note: The above accessories do not include the collector probe, which is included in the EVOSOL accessory (code 20120499) or it can be purchased separately through the SOLAR COLLECTOR PROBE KIT (code 20008787).

For other accessories, refer to the SOLAR THERMAL ACCESSORIES section of the Product Catalogue.

Forced circulation systems

## SCF-25/4B A SYSTEM - SYSTEM COMPOSITION

### SCF-25/4B A 200/1 (COD. 20207663) (1)

CODE	DESCRIPTION	QUANTITY
20201328	SCF 25/4B A	1
20119552	IDRA DS 200 FI	1
4383059	10 kg glycol	1
4383052	18 lt expansion vessel	1
20020778	1" mixing valve	1
20201448	Hydraulic kit for 1 "A" solar collector	1

(1) To complete the installation it is necessary to purchase the complete bracket kits.

### SCF-25/4B A 300/2 (COD. 20207664) (1)

CODE	DESCRIPTION	QUANTITY
20201329	SCF-25/4B A x 2	1
20119553	IDRA DS 300 FI	1
4383059	10 kg glycol	1
4383052	18 lt expansion vessel	1
20020778	1" mixing valve	1
20201449	Hydraulic kit for 2 "A" solar collectors	1

(1) To complete the installation it is necessary to purchase the complete bracket kits.

### SCF-25/4B A 400/3 (COD. 20207657) (1)

CODE	DESCRIPTION	QUANTITY
20201328	SCF 25/4B A	1
20201329	SCF-25/4B A x 2	1
20119554	IDRA DS 430 FI	1
4383085	5 kg glycol	1
4383059	10 kg glycol	1
4383052	18 lt expansion vessel	1
20020778	1" mixing valve	1
20201450	Hydraulic kit for 3 "A" solar collectors	1

(1) To complete the installation it is necessary to purchase the complete bracket kits.

## SCF-25/4B A SYSTEM - COMPLETE BRACKET KITS, FOR VERTICAL ASSEMBLY

### COMPONENTS FOR VERTICAL INSTALLATIONS AT 30 OR 45° ON FLAT ROOF FOR SCF-25/4B A SOLAR COLLECTORS

	Brackets 1 coll. 2,5m <sup>2</sup> "A" FR 30-45	Extension +1 coll. 2,5m <sup>2</sup> "A" FR 30-45	Hydraulic kit for 1 collector A	Hydraulic kit for 2 collectors A	Hydraulic kit for 3 collectors A	Hydraulic kit for 4 collectors A	Hydraulic kit for 5 collectors A	Hydraulic kit for 6 collectors A	Hydraulic kit for 7 collectors A	Hydraulic kit for 8 collectors A	Hydraulic kit for 9 collectors A	Hydraulic kit for 10 collectors A
	20201443	20201444	20201448	20201449	20201450	20201451	20201453	20201454	20201455	20201457	20201458	20201459
Kit for 1 coll 2,5m <sup>2</sup> TP 30-45°	1		1									
Kit for 2 coll 2,5m <sup>2</sup> TP 30-45°	1	1		1								
Kit for 3 coll 2,5m <sup>2</sup> TP 30-45°	1	2			1							
Kit for 4 coll 2,5m <sup>2</sup> TP 30-45°	1	3				1						
Kit for 5 coll 2,5m <sup>2</sup> TP 30-45°	1	4					1					
Kit for 6 coll 2,5m <sup>2</sup> TP 30-45°	1	5						1				
Kit for 7 coll 2,5m <sup>2</sup> TP 30-45°	1	6							1			
Kit for 8 coll 2,5m <sup>2</sup> TP 30-45°	1	7								1		
Kit for 9 coll 2,5m <sup>2</sup> TP 30-45°	1	8									1	
Kit for 10 coll 2,5m <sup>2</sup> TP 30-45°	1	9										1

### COMPONENTS FOR VERTICAL INSTALLATIONS AT 30 OR 45° ON FLAT ROOF FOR SCF-20/4B A AND SCF-25/4B A SOLAR COLLECTORS

	BRACKETS 1 COLL. 2-2,5 "A" under tile IR	BRACKETS 2 COLL. 2-2,5 "A" under tile IR	EXTENSION +1 COLL. 2-2,5 A under tile IR	KIT 4 HOOKS FOR IR - COLL. A	KIT 6 HOOKS FOR IR - COLL. A	Hydraulic kit for 1 collector A	Hydraulic kit for 2 collector A	Hydraulic kit for 3 collector A	Hydraulic kit for 4 collector A	Hydraulic kit for 5 collector A	Hydraulic kit for 6 collector A	Hydraulic kit for 7 collector A	Hydraulic kit for 8 collector A	Hydraulic kit for 9 collector A	Hydraulic kit for 10 collector A
	20201446	20201447	20201611	20201445	20202639	20201448	20201449	20201450	20201451	20201453	20201454	20201455	20201457	20201458	20201459
Kit for 1 coll 2-2,5m <sup>2</sup> TI	1			1		1									
Kit for 2 coll 2-2,5m <sup>2</sup> TI		1			1		1								
Kit for 3 coll 2-2,5m <sup>2</sup> TI		1	1	1	1			1							
Kit for 4 coll 2-2,5m <sup>2</sup> TI		1	2	2	1				1						
Kit for 5 coll 2-2,5m <sup>2</sup> TI		1	3	3	1					1					
Kit for 6 coll 2-2,5m <sup>2</sup> TI		1	4	4	1						1				
Kit for 7 coll 2-2,5m <sup>2</sup> TI		1	5	5	1							1			
Kit for 8 coll 2-2,5m <sup>2</sup> TI		1	6	6	1								1		
Kit for 9 coll 2-2,5m <sup>2</sup> TI		1	7	7	1									1	
Kit for 10 coll 2-2,5m <sup>2</sup> TI		1	8	8	1										1



- (A) Sealed collector with prepainted galvanized steel profile - 2 sq.m
- (B) EVOSOL solar control box
- (C) IDRA cylinder with increased coil surface
- (D) Solar hydraulic return group for wall-mounting installation with circulator suitable for PVM and ON/OFF management
- (E) Glycol
- (F) Solar expansion vessel
- (G) 3/4" thermostatic mixing valve
- (H) Hydraulic panel fittings for SCF 20/4 A systems



SOLAR KEYMARK  
certification

## SYSTEMS FOR FLAT AND PITCHED ROOF - BRACKETS NOT INCLUDED

CODE	MODEL	NUMBER OF COLLECTORS	CYLINDER CAPACITY (l)	COLLECTORS DIMENSIONS H x W (mm)	COLLECTORS TOTAL AREA (m <sup>2</sup> )
<b>SYSTEMS WITH DOUBLE-COIL HEATER</b>					
20207644	SCF-20/4B A 200/1	1	208 double coil	1818 x 1097	1,91
20207652	SCF-20/4B A 300/2	2	301 double coil	1818 x 2194	3,82
20207654	SCF-20/4B A 400/3	3	430 double coil	1818 x 3291	5,73
20207656	SCF-20/4B A 500/4	4	551 double coil	1818 x 4388	7,64

To complete the installation it is necessary to purchase the complete bracket kits, choosing them according to the number of collectors, from slanting roof bracket kit, undertile roof bracket kit for slanting roof and flat roof bracket kit.

**ACCESSORIES**

CODE	MODEL
<b>ACCESSORIES FOR FLAT ROOF (FR 30-45°)</b>	
20201441	Brackets 1 solar collector 2m <sup>2</sup> "A" FR 30-45°
20201442	Extension brackets for 1 additional solar collector 2m <sup>2</sup> "A" FR 30-45°
<b>ACCESSORIES FOR PITCHED ROOF (PR)</b>	
20201446	Brackets 1 solar collector 2-2,5m <sup>2</sup> "A" undertile PR
20201447	Brackets 2 solar collectors 2-2,5m <sup>2</sup> "A" undertile PR
20201611	Extension brackets for 1 additional solar collector 2-2,5m <sup>2</sup> "A" undertile PR <sup>(1)</sup>
20201445	Kit 4 brackets hooks for PR - "A" solar collector
20202639	Kit 6 brackets hooks for PR - "A" solar collector
<b>HYDRAULIC KIT FOR SOLAR COLLECTOR "A"</b>	
20201448	Hydraulic kit for 1 "A" solar collector
20201449	Hydraulic kit for 2 "A" solar collectors
20201450	Hydraulic kit for 3 "A" solar collectors
20201451	Hydraulic kit for 4 "A" solar collectors
20201453	Hydraulic kit for 5 "A" solar collectors
20201454	Hydraulic kit for 6 "A" solar collectors
20201455	Hydraulic kit for 7 "A" solar collectors
20201457	Hydraulic kit for 8 "A" solar collectors
20201458	Hydraulic kit for 9 "A" solar collectors
20201459	Hydraulic kit for 10 "A" solar collectors

(1) Add this extension brackets only to the code 20201447 (Brackets 2 solar collectors 2-2,5m<sup>2</sup> "A" undertile PR)

Note: The above accessories do not include the collector probe, which is included in the EVOSOL accessory (code 20120499) or it can be purchased separately through the SOLAR COLLECTOR PROBE KIT (code 20008787).

For other accessories, refer to the SOLAR THERMAL ACCESSORIES section of the Product Catalogue.

Forced circulation systems

## SCF-20/4B A SYSTEM - SYSTEM COMPOSITION

### SCF-20/4B A 200/1 (COD. 20207644) (1)

CODE	DESCRIPTION	QUANTITY
20201335	SCF-20/4B A	1
20120499	Solar control box EVOSOL with probes	1
20117881	IDRA DS 200 (B class) cylinder	1
20116162	7,5 m CONNECT SOLAR R - only return hydraulic group	1
4383085	5 kg glycol	1
4383052	18 lt expansion vessel	1
20020778	1" mixing valve	1
20201448	Hydraulic kit for 1 "A" solar collector	1

(1) To complete the installation it is necessary to purchase the complete bracket kits

### SCF-20/4B A 300/2 (COD. 20207652) (1)

CODE	DESCRIPTION	QUANTITY
20201336	SCF-20/4B A x 2	1
20120499	Solar control box EVOSOL with probes	1
20117882	IDRA DS 300 (B class) cylinder	1
20116162	7,5 m CONNECT SOLAR R - only return hydraulic group	1
4383085	5 kg glycol	1
4383052	18 lt expansion vessel	1
20020778	1" mixing valve	1
20201449	Hydraulic kit for 2 "A" solar collector	1

(1) To complete the installation it is necessary to purchase the complete bracket kits

## SCF-20/4B A SYSTEM - SYSTEM COMPOSITION

### SCF-20/4B A 400/3 (COD.20207654) (1)

CODE	DESCRIPTION	QUANTITY
20201335	SCF-20/4B A	1
20201336	SCF 20/4B A x 2	1
20120499	Solar control box EVOSOL with probes	1
20117883	IDRA DS 430 (B class) cylinder	1
20116162	7,5 m CONNECT SOLAR R - only return hydraulic group	1
20009190	2,5 kg glycol	1
4383059	10 kg glycol	1
4383053	24 lt expansion vessel	1
20020778	1" mixing valve	1
20201450	Hydraulic kit for 3 "A" solar collector	1

(1) To complete the installation it is necessary to purchase the complete bracket kits SCF-20/4B A 500/4 (cod.20207656) (1)

### SCF-20/4B A 500/4 (COD. 20207656) (1)

CODE	DESCRIPTION	QUANTITY
20201336	SCF 20/4B A x 2	1
20120499	Solar control box EVOSOL with probes	1
20117884	IDRA DS 550 (B class) cylinder	1
20116162	7,5 m CONNECT SOLAR R - only return hydraulic group	1
4383085	5 kg glycol	1
4383059	10 kg glycol	1
4383053	24 lt expansion vessel	1
20020778	1" mixing valve	1
20201451	Hydraulic kit for 4 "A" solar collector	1

(1) To complete the installation it is necessary to purchase the complete bracket kits

## SCF-20/4B A SYSTEM - COMPLETE BRACKET KITS

### COMPONENTS FOR VERTICAL INSTALLATIONS AT 30 OR 45° ON FLAT ROOF FOR SCF-25/4B A SOLAR COLLECTORS

	Brackets 1 coll. 2m2 "A" FR 30-45	Extension *1 coll. 2m2 "A" FR 30-45	Hydraulic kit for 1 collector A	Hydraulic kit for 2 collectors A	Hydraulic kit for 3 collectors A	Hydraulic kit for 4 collectors A	Hydraulic kit for 5 collectors A	Hydraulic kit for 6 collectors A	Hydraulic kit for 7 collectors A	Hydraulic kit for 8 collectors A	Hydraulic kit for 9 collectors A	Hydraulic kit for 10 collectors A
	20201441	20201442	20201448	20201449	20201450	20201451	20201453	20201454	20201455	20201457	20201458	20201459
Kit for 1 coll 2m <sup>2</sup> TP 30-45°	1		1									
Kit for 2 coll 2m <sup>2</sup> TP 30-45°	1	1		1								
Kit for 3 coll 2m <sup>2</sup> TP 30-45°	1	2			1							
Kit for 4 coll 2m <sup>2</sup> TP 30-45°	1	3				1						
Kit for 5 coll 2m <sup>2</sup> TP 30-45°	1	4					1					
Kit for 6 coll 2m <sup>2</sup> TP 30-45°	1	5						1				
Kit for 7 coll 2m <sup>2</sup> TP 30-45°	1	6							1			
Kit for 8 coll 2m <sup>2</sup> TP 30-45°	1	7								1		
Kit for 9 coll 2m <sup>2</sup> TP 30-45°	1	8									1	
Kit for 10 coll 2m <sup>2</sup> TP 30-45°	1	9										1

### COMPONENTS FOR VERTICAL INSTALLATIONS AT 30 OR 45° ON FLAT ROOF FOR SCF-20/4B A AND SCF-25/4B A SOLAR COLLECTORS

	BRACKETS 1 COLL. 2-2,5 "A" under tile IR	BRACKETS 2 COLL. 2-2,5 "A" under tile IR	EXTENSION *1 COLL. 2-2,5 A under tile IR	KIT 4 HOOKS FOR IR - COLL. A	KIT 6 HOOKS FOR IR - COLL. A	Hydraulic kit for 1 collector A	Hydraulic kit for 2 collector A	Hydraulic kit for 3 collector A	Hydraulic kit for 4 collector A	Hydraulic kit for 5 collector A	Hydraulic kit for 6 collector A	Hydraulic kit for 7 collector A	Hydraulic kit for 8 collector A	Hydraulic kit for 9 collector A	Hydraulic kit for 10 collector A
	20201446	20201447	20201611	20201445	20202639	20201448	20201449	20201450	20201451	20201453	20201454	20201455	20201457	20201458	20201459
Kit for 1 coll 2-2,5m <sup>2</sup> TI	1			1		1									
Kit for 2 coll 2-2,5m <sup>2</sup> TI		1			1		1								
Kit for 3 coll 2-2,5m <sup>2</sup> TI		1	1	1	1			1							
Kit for 4 coll 2-2,5m <sup>2</sup> TI		1	2	2	1				1						
Kit for 5 coll 2-2,5m <sup>2</sup> TI		1	3	3	1					1					
Kit for 6 coll 2-2,5m <sup>2</sup> TI		1	4	4	1						1				
Kit for 7 coll 2-2,5m <sup>2</sup> TI		1	5	5	1							1			
Kit for 8 coll 2-2,5m <sup>2</sup> TI		1	6	6	1								1		
Kit for 9 coll 2-2,5m <sup>2</sup> TI		1	7	7	1									1	
Kit for 10 coll 2-2,5m <sup>2</sup> TI		1	8	8	1										1



## Natural circulation system NB-SOL-A SYSTEM



- Natural circulation system for the production of DHW, performing best in areas with high levels of sunlight and mild winters.
- Ready-to-be-installed system, complete with collector(s), cylinder, brackets, fittings and glycol.
- High selective absorber surface.
- Ease of functioning: no need of any additional components such as a circulator or an electronic controller.
- Collector stagnation temperature: 180 °C.
- Magnesium anode and electrical resistance included with the standard equipment.
- DHW and solar safety valves (10 bar and 2.5 bar).
- Enamelled double-walled steel cylinder with polyurethane insulation.
- NB-SOL-A system can be matched with combi wall-hung boilers.
- Solar panels with Solar Keymark certification.
- Solar systems with Solar Keymark certification.
- Systems conform to the EN12975 and EN12976 standards.



SOLAR KEYMARK  
certification

### KIT FOR FLAT ROOF WITH 45° OF INCLINATION

CODE	MODEL	NUMBER OF COLLECTORS	CYLINDER CAPACITY (litres)	COLLECTORS DIMENSIONS H x W (mm)	COLLECTORS TOTAL AREA (m <sup>2</sup> )
20202410	NB-SOL-A 160/2,5 TP	1	151	2020 x 1235 x 85	2,49
20202411	NB-SOL-A 200/2,5 TP	1	192	2020 x 1235 x 85	2,49
20202412	NB-SOL-A 200/4 TP	2	192	1625 x 1235 x 85	4
20202414	NB-SOL-A 300/4 TP	2	295	1625 x 1235 x 85	4
20202415	NB-SOL-A 300/5 TP	2	295	2020 x 1235 x 85	4,98

### KIT FOR INCLINED ROOF

CODE	MODEL	NUMBER OF COLLECTORS	CYLINDER CAPACITY (litres)	COLLECTORS DIMENSIONS H x W (mm)	COLLECTORS TOTAL AREA (m <sup>2</sup> )
20202229	NB-SOL-A 160/2,5 TI	1	151	2020 x 1235 x 85	2,49
20202231	NB-SOL-A 200/2,5 TI	1	192	2020 x 1235 x 85	2,49
20202233	NB-SOL-A 200/4 TI	2	192	1625 x 1235 x 85	4
20202238	NB-SOL-A 300/4 TI	2	295	1625 x 1235 x 85	4
20202240	NB-SOL-A 300/5 TI	2	295	2020 x 1235 x 85	4,98

NB-SOL-A systems include brackets.  
We recommend installing an expansion tank suitable for the capacity of the boiler.

Natural circulation system

## NB-SOL-A SYSTEM

### ACCESSORIES

CODE	DESCRIPTION
20020778	3/4" thermostatic mixing valve

#### NB-SOL TP

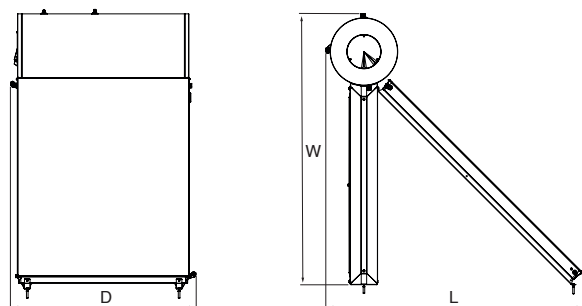

#### NB-SOL TI

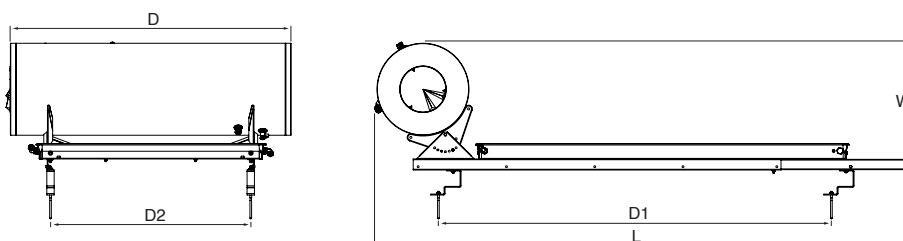

		NB-SOL a									
DESCRIPTION		160/2,5 TP	200/2,5 TP	200/4 TP	300/4 TP	300/5 TP	160/2,5 TI	200/2,5 TI	200/4 TI	300/4 TI	300/5 TI
Net weight	kg	93,4	108,4	131,3	154,3	166,8	93,4	108,4	131,3	154,3	166,8
W	mm	1903	1903	1626	1626	1903	2936	2936	2948	2948	2948
D	mm	1314	1526	2578	2578	2524	1314	1526	2498	2498	2498
H	mm	2006	2006	1727	1727	2006	689	689	689	689	689
D1	mm	-	-	-	-	-	2137	2137	2137	2137	2137
D2	mm	-	-	-	-	-	1089	1089	1089	1089	1089
Liquid	l	2	3	3	4	4	2	3	3	4	4

# NATURAL CIRCULATION SYSTEM FOR DHW PRODUCTION WITH COMBINED BOILER INTEGRATION

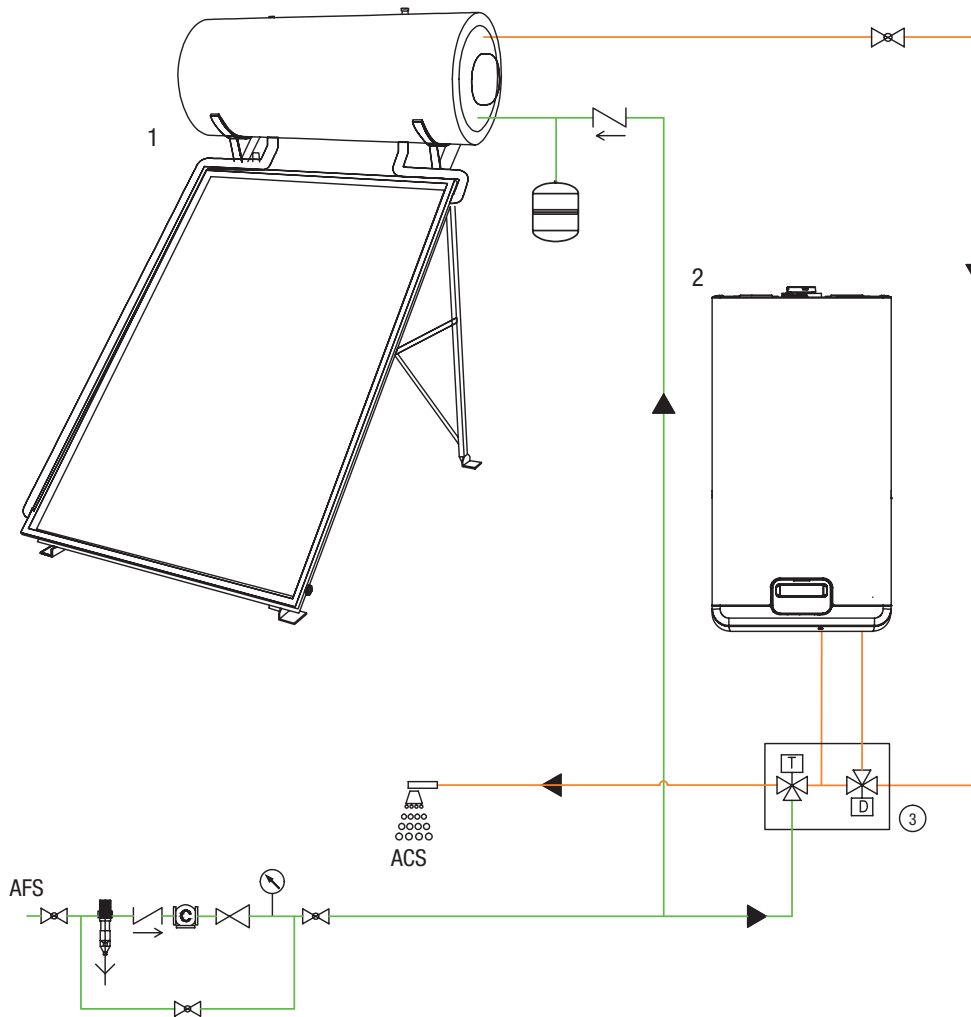

Basic layout purely for illustrative purposes

**Key:**

- (1) NB-SOL A natural circulation system with SCF-25/4B A and SCF-20/4B A profiled collectors
- (2) EXCLUSIVE C condensing boiler
- (3) Domestic water diverting/mixing valve

## NATURAL CIRCULATION SYSTEM FOR DHW PRODUCTION WITH COMBINED BOILER INTEGRATION

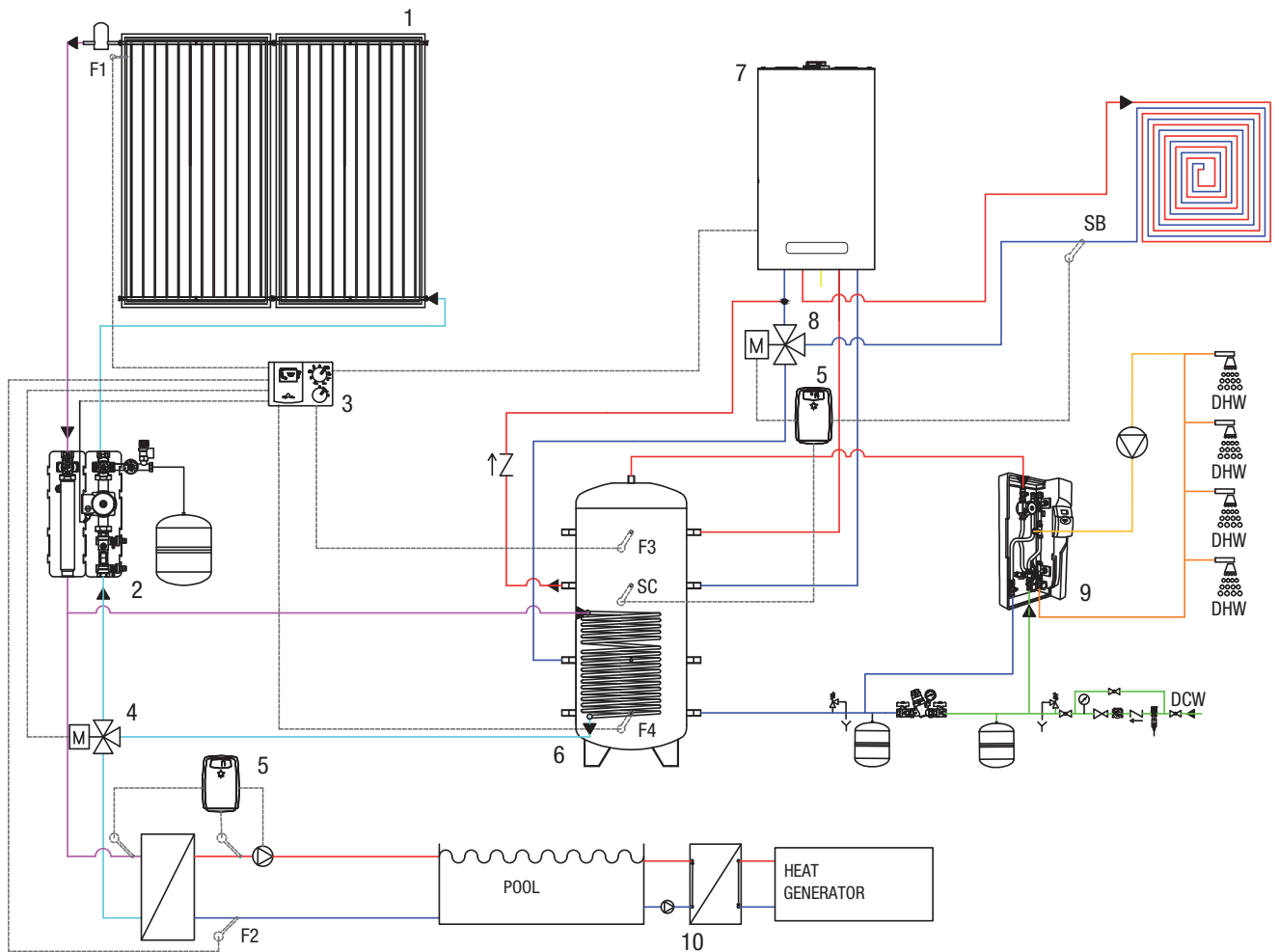

Purely indicative diagram

### Key:

- (1) Flat solar collectors
- (2) Solar hydraulic flow and return unit
- (3) SUN 5 solar control unit
- (4) Motorized solar storage/pool diverter valve
- (5) Mains water softener
- (6) STOR M single-coil buffer tank
- (7) Condensing boiler
- (8) Motorized BT system return diverter valve
- (9) ACS 30 domestic hot water production module
- (10) SP inspectable plate heat exchanger

- F1 Solar collector sensor
- F3 Upper storage tank sensor
- F4 Lower storage tank sensor
- SB Radiant panel system return sensor
- SC Central storage tank sensor

**DIVERTER VALVES AND THERMOSTATIC VALVES**

CODE	DESCRIPTION
1150529	3/4" Mixing valve
20020778	1" thermostatic mixing valve with 3/4" adapter



CODE	DESCRIPTION
20035644	Solar diverter mixing valve kit (for combination boilers) *

\* The mixing valve is not designed for installation in built-in BOXES.

**EXPANSION VESSEL**

CODE	DESCRIPTION
4383052	18 lt expansion vessel
4383053	24 lt expansion vessel
4383054	35 lt expansion vessel
1150499	Bracket for wall installation of expansion tank 18-24 liters.
4383256	50 lt expansion vessel
4383257	100 lt expansion vessel

**GLYCOL AND ACCESSORIES**

CODE	DESCRIPTION
20009190	2,5 kg glycol
4383085	5 kg glycol
4383059	10 kg glycol
20011536	Flow rate regulator 12 (DN20; 2-12 l/min; kvs=2,2 m³/h)
20026577	Manual bleed valve kit



- Sealed solar collector with pre-painted galvanized steel frame - 2,5m<sup>2</sup>
- Connection between solar collectors with 4 tightening fittings
- Highly-selective absorber area with TiNO<sub>x</sub> treatment
- Insulation in glass wool (30mm)
- Collector absorption: 95%
- Collector stagnation temperature: 180°C
- Possibility to connect up to 10 vertical solar collectors
- This solar collector conforms to the EN 12975
- Solar Keymark Certification



SOLAR KEYMARK  
certification

### SEALED SOLAR COLLECTOR WITH PRE-PAINTED GALVANIZED STEEL FRAME - 2,5 M<sup>2</sup>

CODE	MODEL	COLLECTORS DIMENSIONS H x W (mm)	COLLECTORS TOTAL AREA (m <sup>2</sup> )
20201328	SCF 25/4B A	2020 x 1235 x 85	2,49

### PACKAGES

CODE	MODEL
20201329	SCF-25/4B A x 2
20201330	SCF-25/4B A x 5
20201805	SCF-25/4B A x 7

## SCF-25/4B A

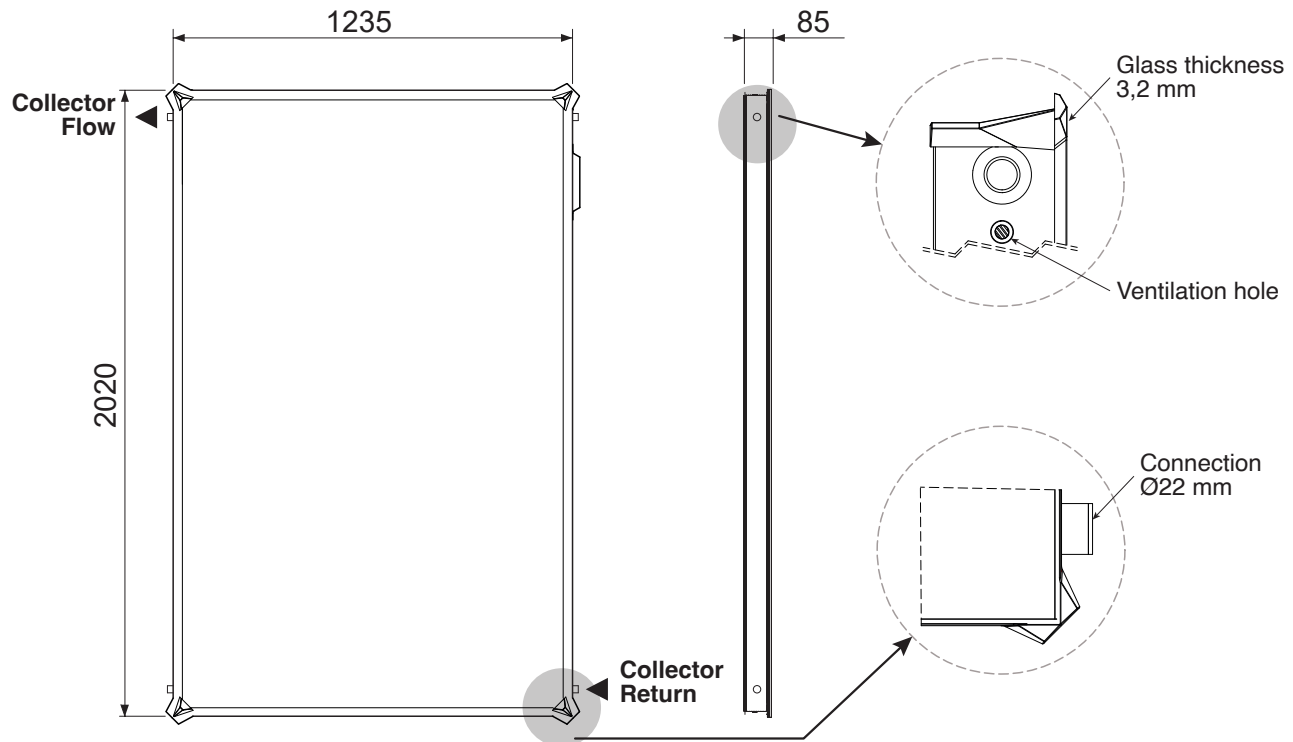

DESCRIPTION	U.D.M.	SOLAR COLLECTOR SCF-25/4B A
Total area	m <sup>2</sup>	2,49
Exposed area	m <sup>2</sup>	2,38
Effective absorption area	m <sup>2</sup>	2,37
Connections	-	G 1
Weight (empty)	kg	35
Liquid content	l	1,55
Glass thickness	mm	3,2
Absorption <sup>(a)</sup>	%	95
Emissions <sup>(e)</sup>	%	5
IAM (50°)	-	0,91
$\eta$ coll. (a 1000 W/m <sup>2</sup> )	%	60
Maximum permitted pressure	bar	10

**ACCESSORIES FOR VERTICAL INSTALLATIONS OF THE SCF - 25/4B A SOLAR COLLECTOR**

CODE	MODEL
<b>ACCESSORIES FOR FLAT ROOF (FR 30-45°)</b>	
20201443	Brackets 1 solar collector 2,5 m <sup>2</sup> "A" FR 30-45°
20201444	Extension brackets for 1 additional solar collector 2,5 m <sup>2</sup> "A" FR 30-45°
<b>ACCESSORIES FOR PITCHED ROOF (PR)</b>	
20201446	Brackets 1 solar collector 2-2,5 m <sup>2</sup> "A" undertile PR
20201447	Brackets 2 solar collectors 2-2,5 m <sup>2</sup> "A" undertile PR
20201611	Extension brackets for 1 additional solar collector 2-2,5 m <sup>2</sup> "A" undertile PR <sup>(1)</sup>
20201445	Kit 4 brackets hooks for PR - "A" solar collector
20202639	Kit 6 brackets hooks for PR - "A" solar collector
<b>HYDRAULIC KIT FOR SOLAR COLLECTOR "A"</b>	
20201448	Hydraulic kit for 1 "A" solar collector
20201449	Hydraulic kit for 2 "A" solar collectors
20201450	Hydraulic kit for 3 "A" solar collectors
20201451	Hydraulic kit for 4 "A" solar collectors
20201453	Hydraulic kit for 5 "A" solar collectors
20201454	Hydraulic kit for 6 "A" solar collectors
20201455	Hydraulic kit for 7 "A" solar collectors
20201457	Hydraulic kit for 8 "A" solar collectors
20201458	Hydraulic kit for 9 "A" solar collectors
20201459	Hydraulic kit for 10 "A" solar collectors

(1) Add this extension brackets only to the code 20201447 (Brackets 2 solar collectors 2-2,5m<sup>2</sup> "A" undertile PR)

Note: The above accessories do not include the collector probe, which is included in the EVOSOL accessory (code 20120499) or it can be purchased separately through the SOLAR COLLECTOR PROBE KIT (code 20008787).

For other accessories, refer to the SOLAR THERMAL ACCESSORIES section of the Product Catalogue.

## SCF-25/4B A

### COMPONENTS FOR VERTICAL INSTALLATIONS AT 30 OR 45° ON FLAT ROOF FOR SCF-25/4B A SOLAR COLLECTORS

	20201443	20201444	20201448	20201449	20201450	20201451	20201453	20201454	20201455	20201457	20201458	20201459
Brackets 1 collector 2,5 m <sup>2</sup> "A" FR 30-45°												
Ext. brackets for 1 add. solar collector 2,5 m <sup>2</sup> "A" FR 30-45°												
Hydraulic kit for 1 "A" solar collector												
Hydraulic kit for 2 "A" solar collector												
Hydraulic kit for 3 "A" solar collector												
Hydraulic kit for 4 "A" solar collector												
Hydraulic kit for 5 "A" solar collector												
Hydraulic kit for 6 "A" solar collector												
Hydraulic kit for 7 "A" solar collector												
Hydraulic kit for 8 "A" solar collector												
Hydraulic kit for 9 "A" solar collector												
Hydraulic kit for 10 "A" solar collector												
Kit for 1 solar collector 2,5 m <sup>2</sup> (TP 30-45°)	1		1									
Kit for 2 solar collectors 2,5 m <sup>2</sup> (TP 30-45°)	1	1		1								
Kit for 3 solar collectors 2,5 m <sup>2</sup> (TP 30-45°)	1	2			1							
Kit for 4 solar collectors 2,5 m <sup>2</sup> (TP 30-45°)	1	3				1						
Kit for 5 solar collectors 2,5 m <sup>2</sup> (TP 30-45°)	1	4					1					
Kit for 6 solar collectors 2,5 m <sup>2</sup> (TP 30-45°)	1	5						1				
Kit for 7 solar collectors 2,5 m <sup>2</sup> (TP 30-45°)	1	6							1			
Kit for 8 solar collectors 2,5 m <sup>2</sup> (TP 30-45°)	1	7								1		
Kit for 9 solar collectors 2,5 m <sup>2</sup> (TP 30-45°)	1	8									1	
Kit for 10 solar collectors 2,5 m <sup>2</sup> (TP 30-45°)	1	9										1

### COMPONENTS FOR VERTICAL INSTALLATIONS ON PITCHED ROOF WITH UNDERTILE BRACKET FOR SCF-20/4B A AND SCF-25/4B A SOLAR COLLECTORS

	20201446	20201447	20201611	20201445	20202639	20201448	20201449	20201450	20201451	20201453	20201454	20201455	20201457	20201458	20201459
Brackets 1 solar collector 2-2,5 m <sup>2</sup> "A", undertile PR															
Brackets 2 solar collectors 2-2,5 m <sup>2</sup> "A", undertile PR															
Ext. brackets for 1 add. solar coll. 2-2,5 m <sup>2</sup> "A", undertile PR (1)															
Kit 4 brackets hooks for PR - "A" solar collector															
Kit 6 brackets hooks for PR - "A" solar collector															
Hydraulic kit for 1 "A" solar collector															
Hydraulic kit for 2 "A" solar collector															
Hydraulic kit for 3 "A" solar collector															
Hydraulic kit for 4 "A" solar collector															
Hydraulic kit for 5 "A" solar collector															
Hydraulic kit for 6 "A" solar collector															
Hydraulic kit for 7 "A" solar collector															
Hydraulic kit for 8 "A" solar collector															
Hydraulic kit for 9 "A" solar collector															
Hydraulic kit for 10 "A" solar collector															
Kit for 1 solar coll. 2-2,5 m <sup>2</sup> (PR)	1			1		1									
Kit for 2 solar coll. 2-2,5 m <sup>2</sup> (PR)		1			1		1								
Kit for 3 solar coll. 2-2,5 m <sup>2</sup> (PR)		1	1	1	1			1							
Kit for 4 solar coll. 2-2,5 m <sup>2</sup> (PR)		1	2	2	1				1						
Kit for 5 solar coll. 2-2,5 m <sup>2</sup> (PR)		1	3	3	1					1					
Kit for 6 solar coll. 2-2,5 m <sup>2</sup> (PR)		1	4	4	1						1				
Kit for 7 solar coll. 2-2,5 m <sup>2</sup> (PR)		1	5	5	1							1			
Kit for 8 solar coll. 2-2,5 m <sup>2</sup> (PR)		1	6	6	1								1		
Kit for 9 solar coll. 2-2,5 m <sup>2</sup> (PR)		1	7	7	1									1	
Kit for 10 solar coll. 2-2,5 m <sup>2</sup> (PR)		1	8	8	1										1



- Sealed solar collector with pre-painted galvanized steel frame - 2m<sup>2</sup>
- Connection between solar collectors with 4 tightening fittings
- Highly-selective absorber area with TiNO<sub>x</sub> treatment
- Insulation in glass wool (30mm)
- Collector absorption: 95%
- Collector stagnation temperature: 180°C
- Possibility to connect up to 10 vertical solar collectors
- This solar collector conforms to the EN 12975
- Solar Keymark Certification



SOLAR KEYMARK  
certification

### SEALED SOLAR COLLECTOR WITH PRE-PAINTED GALVANIZED STEEL FRAME - 2 M<sup>2</sup>

CODE	MODEL	COLLECTORS DIMENSIONS H x W (mm)	COLLECTORS TOTAL AREA (m <sup>2</sup> )
20201335	SCF 20/4B A	1625 x 1235 x 85	2

### PACKAGES

CODE	MODEL
20201336	Pack of 2 pcs. SCF 20/4B A single package
20201337	Pack of 7 pcs. SCF 20/4B A single package

## SCF-20/4B A

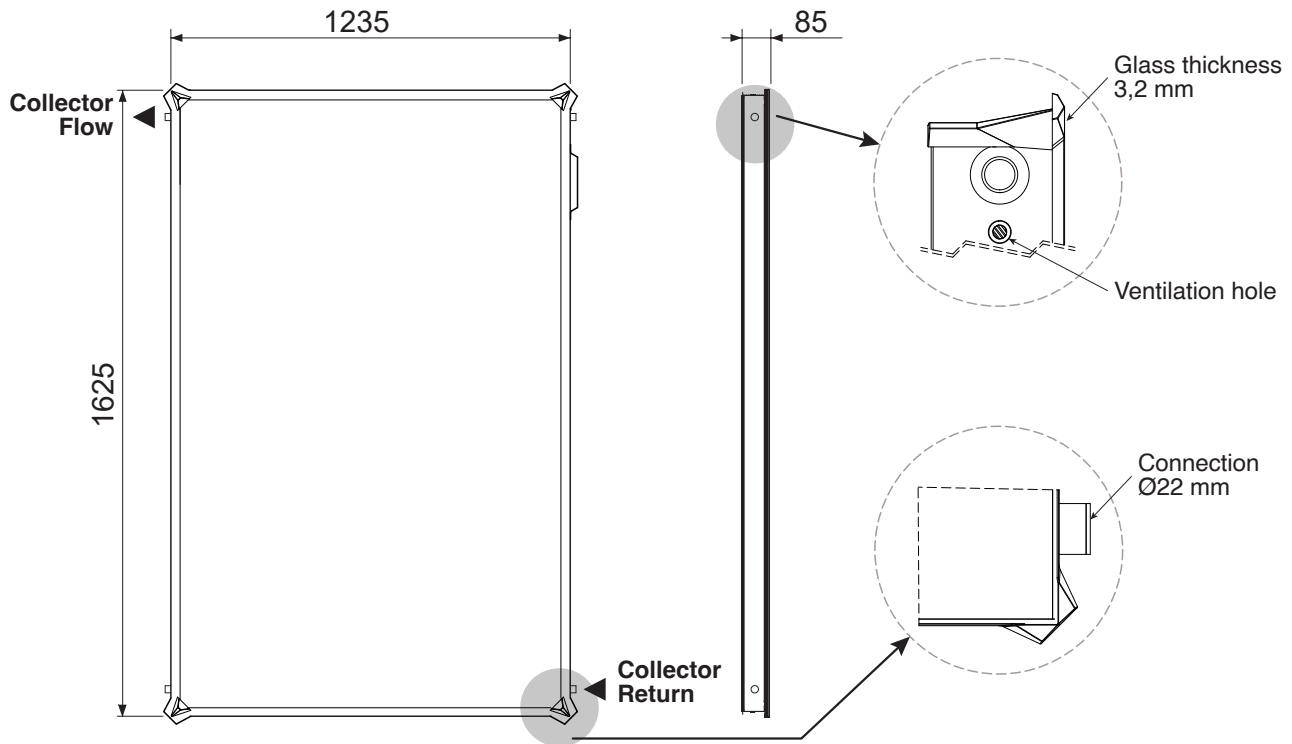

DESCRIPTION	U.D.M.	SOLAR COLLECTOR SCF-25/4B A
Total area	m <sup>2</sup>	2
Exposed area	m <sup>2</sup>	1,9
Effective absorption area	m <sup>2</sup>	1,9
Connections	-	G 1
Weight (empty)	kg	29
Liquid content	l	1,3
Glass thickness	mm	3,2
Absorption <sup>(a)</sup>	%	95
Emissions <sup>(e)</sup>	%	5
IAM (50°)	-	0,91
$\eta$ coll. (a 1000 W/m <sup>2</sup> )	%	60
Maximum permitted pressure	bar	10

**ACCESSORIES FOR VERTICAL INSTALLATIONS OF THE SCF - 20/4B A SOLAR COLLECTOR**

CODE	MODEL
<b>ACCESSORIES FOR FLAT ROOF (FR 30-45°)</b>	
20201441	Brackets 1 solar collector 2 m <sup>2</sup> "A" FR 30-45°
20201442	Extension brackets for 1 additional solar collector 2 m <sup>2</sup> "A" FR 30-45°
<b>ACCESSORIES FOR PITCHED ROOF (PR)</b>	
20201446	Brackets 1 solar collector 2-2,5 m <sup>2</sup> "A" undertile PR
20201447	Brackets 2 solar collectors 2-2,5 m <sup>2</sup> "A" undertile PR
20201611	Extension brackets for 1 additional solar collector 2-2,5 m <sup>2</sup> "A" undertile PR <sup>(1)</sup>
20201445	Kit 4 brackets hooks for PR - "A" solar collector
20202639	Kit 6 brackets hooks for PR - "A" solar collector
<b>HYDRAULIC KIT FOR SOLAR COLLECTOR "A"</b>	
20201448	Hydraulic kit for 1 "A" solar collector
20201449	Hydraulic kit for 2 "A" solar collectors
20201450	Hydraulic kit for 3 "A" solar collectors
20201451	Hydraulic kit for 4 "A" solar collectors
20201453	Hydraulic kit for 5 "A" solar collectors
20201454	Hydraulic kit for 6 "A" solar collectors
20201455	Hydraulic kit for 7 "A" solar collectors
20201457	Hydraulic kit for 8 "A" solar collectors
20201458	Hydraulic kit for 9 "A" solar collectors
20201459	Hydraulic kit for 10 "A" solar collectors

(1) Add this extension brackets only to the code 20201447 (Brackets 2 solar collectors 2-2,5m<sup>2</sup> "A" undertile PR)

Note: The above accessories do not include the collector probe, which is included in the EVOSOL accessory (code 20120499) or it can be purchased separately through the SOLAR COLLECTOR PROBE KIT (code 20008787).

For other accessories, refer to the SOLAR THERMAL ACCESSORIES section of the Product Catalogue.

## SCF-20/4B A

### COMPONENTS FOR VERTICAL INSTALLATIONS AT 30 OR 45° ON FLAT ROOF FOR SCF-20/4B A SOLAR COLLECTORS

	20201441	20201442	20201448	20201449	20201450	20201451	20201453	20201454	20201455	20201457	20201458	20201459
	Brackets 1 collector 2 m <sup>2</sup> "A" FR 30-45°	Ext. brackets for 1 add. solar collector 2 m <sup>2</sup> "A" FR 30-45°	Hydraulic kit for 1 "A" solar collector	Hydraulic kit for 2 "A" solar collector	Hydraulic kit for 3 "A" solar collector	Hydraulic kit for 4 "A" solar collector	Hydraulic kit for 5 "A" solar collector	Hydraulic kit for 6 "A" solar collector	Hydraulic kit for 7 "A" solar collector	Hydraulic kit for 8 "A" solar collector	Hydraulic kit for 9 "A" solar collector	Hydraulic kit for 10 "A" solar collector
Kit for 1 solar collector 2 m <sup>2</sup> (TP 30-45°)	1		1									
Kit for 2 solar collectors 2 m <sup>2</sup> (TP 30-45°)	1	1		1								
Kit for 3 solar collectors 2 m <sup>2</sup> (TP 30-45°)	1	2			1							
Kit for 4 solar collectors 2 m <sup>2</sup> (TP 30-45°)	1	3				1						
Kit for 5 solar collectors 2 m <sup>2</sup> (TP 30-45°)	1	4					1					
Kit for 6 solar collectors 2 m <sup>2</sup> (TP 30-45°)	1	5						1				
Kit for 7 solar collectors 2 m <sup>2</sup> (TP 30-45°)	1	6							1			
Kit for 8 solar collectors 2 m <sup>2</sup> (TP 30-45°)	1	7								1		
Kit for 9 solar collectors 2 m <sup>2</sup> (TP 30-45°)	1	8									1	
Kit for 10 solar collectors 2 m <sup>2</sup> (TP 30-45°)	1	9										1

### COMPONENTS FOR VERTICAL INSTALLATIONS ON PITCHED ROOF WITH UNDERTILE BRACKET FOR SCF-20/4B A AND SCF-25/4B A SOLAR COLLECTORS

	20201446	20201447	20201611	20201445	20202639	20201448	20201449	20201450	20201451	20201453	20201454	20201455	20201457	20201458	20201459
	Brackets 1 solar collector 2-2,5 m <sup>2</sup> "A" undertile PR	Brackets 2 solar collectors 2-2,5 m <sup>2</sup> "A" undertile PR	Ext. brackets for 1 add. solar coll. 2-2,5 m <sup>2</sup> "A" undertile PR (1)	Kit 4 brackets hooks for PR - "A" solar collector	Kit 6 brackets hooks for PR - "A" solar collector	Hydraulic kit for 1 "A" solar collector	Hydraulic kit for 2 "A" solar collector	Hydraulic kit for 3 "A" solar collector	Hydraulic kit for 4 "A" solar collector	Hydraulic kit for 5 "A" solar collector	Hydraulic kit for 6 "A" solar collector	Hydraulic kit for 7 "A" solar collector	Hydraulic kit for 8 "A" solar collector	Hydraulic kit for 9 "A" solar collector	Hydraulic kit for 10 "A" solar collector
Kit for 1 solar coll. 2-2,5 m <sup>2</sup> (PR)	1			1		1									
Kit for 2 solar coll. 2-2,5 m <sup>2</sup> (PR)		1			1		1								
Kit for 3 solar coll. 2-2,5 m <sup>2</sup> (PR)		1	1	1	1			1							
Kit for 4 solar coll. 2-2,5 m <sup>2</sup> (PR)		1	2	2	1				1						
Kit for 5 solar coll. 2-2,5 m <sup>2</sup> (PR)		1	3	3	1					1					
Kit for 6 solar coll. 2-2,5 m <sup>2</sup> (PR)		1	4	4	1						1				
Kit for 7 solar coll. 2-2,5 m <sup>2</sup> (PR)		1	5	5	1							1			
Kit for 8 solar coll. 2-2,5 m <sup>2</sup> (PR)		1	6	6	1								1		
Kit for 9 solar coll. 2-2,5 m <sup>2</sup> (PR)		1	7	7	1									1	
Kit for 10 solar coll. 2-2,5 m <sup>2</sup> (PR)		1	8	8	1										1

**IDRA DS FI - WITH LOW ENERGY HYDRAULIC GROUP AND SOLAR CONTROL BOX**

- Solar cylinders with pre-installed flow/return hydraulic group (featuring a Low Energy modulating circulator) and EVOSOL solar control box
- Vertical steel enamelled solar cylinder with double coil
- Sacrificial magnesium anode included with the standard equipment
- Maximum working temperature 99°C
- Coils and cylinders maximum working pressure: 10 bar
- Hydraulic group safety valve maximum working pressure: 6 bar
- High heat exchange capacity of the coils
- Suitable for electrical resistance

**CYLINDER WITH LOW ENERGY HYDRAULIC GROUP AND SOLAR CONTROL BOX**

CODE	MODEL	DIMENSIONS H x Ø (mm)	CYLINDER CAPACITY (litres)	LOSSES (W)	CLASS
<b>DOUBLE COIL CYLINDERS</b>					
20119552	IDRA DS 200 FI	1338 x 604	208 double coil	62	B
20119553	IDRA DS 300 FI	1838 x 604	301 double coil	69	B
20119554	IDRA DS 430 FI	1644 x 755	430 double coil	75	B

For EXPANSION VESSELS see the dedicated section "ACCESSORIES FOR SOLAR THERMAL".

**ACCESSORIES**

CODE	DESCRIPTION
20020778	1" thermostatic mixing valve with 3/4" adapter
20119911	1.5 kW Single-phase flanged electrical resistance
20119912	2.2 kW Single-phase flanged electrical resistance
20119913	3 kW Single-phase flanged electrical resistance
20119914	3.8 kW Three-phase flanged electrical resistance
20123853	Electrical anode kit <sup>(1)</sup>
20123850	Cylinder thermometer kit

**IDRA DS FI - WITH LOW ENERGY HYDRAULIC GROUP AND SOLAR CONTROL BOX**

CODE	DESCRIPTION
20123849	Bend kit for recirculation
20123851	Bend kit for electrical anode (2)

(1) To connect the electrical anode kit to the EVOSOL solar control box, provide a reduction (not supplied as standard).

(2) Necessary in case of recirculation system only.

N.B. The sacrificial magnesium anode should be periodically monitored and replaced.

N.B. Beretta strongly recommend to connect the tanks to the electrical earth of the plant.

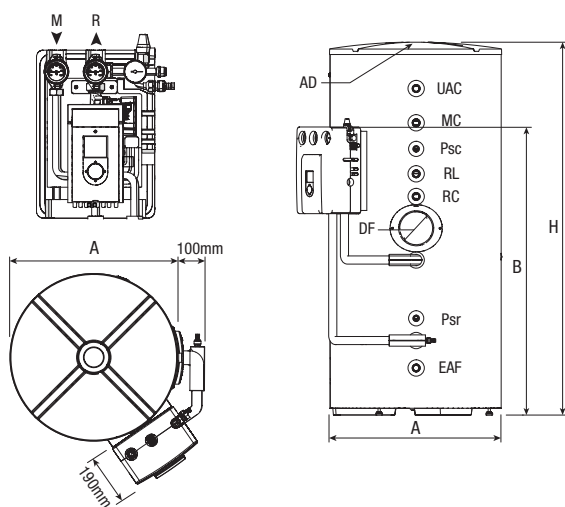

**SOLAR**  
M Flow  
R Return

**BOILER**  
MC Flow  
RC Return

UAC DHW outlet  
RL DHW recirculation  
EAF Domestic cold water inlet  
Psc Boiler probe socket  
Psr Solar control-box probe socket  
AD Magnesium anode  
DF Flange internal diameter

**TECHNICAL SPECIFICATIONS**

DESCRIPTION	U.O.M.	IDRA DS 200 FI	IDRA DS 300 FI	IDRA DS 430 FI
Cylinder capacity	l	208	301	430
Cylinder diameter with insulation without hydraulic group (A)	mm	604		755
Height with insulation (H)	mm	1338	1838	1644
Height hydraulic group connections (B)	mm	1120	1420	1270
Insulation thickness	mm	50		
Probe sockets diameter/length	mm	16/180		
Lower coil water content	l	3.5	5.0	7.0
Upper coil water content	l	3.5	4.0	5.0
Lower coil exchange surface	m <sup>2</sup>	0.7	1.0	1.4
Upper coil exchange surface	m <sup>2</sup>	0.7	0.8	1.0
Maximum operating temperature	°C	99		
Net weight	kg	100	122	145

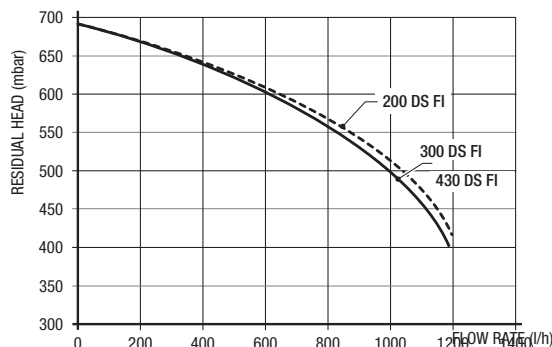
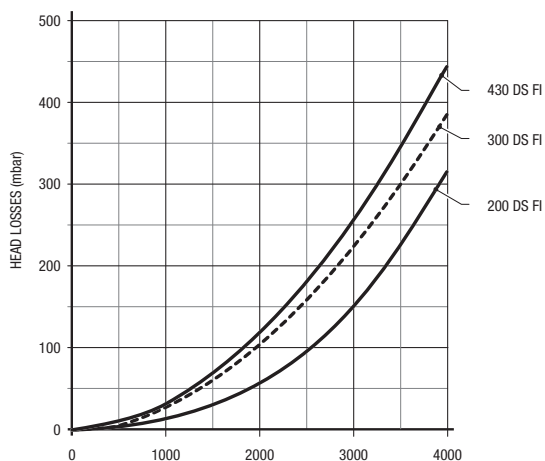

**IDRA DS - WITH INCREASED COIL SURFACE**

- Enamelled (double layer) steel solar cylinder
- Double coil heat-exchanger
- Maximum working temperature: 99°C
- High heat exchange capacity of the coils
- Suitable for flanged electrical resistance
- Coils and cylinders maximum working pressure: 10 bar (only Idra DS 200 - 550)
- Coils and cylinders maximum working pressure: 7 bar (only Idra DS 750 - 1000)
- Magnesium anode included with the standard equipment (only Idra DS 200 - 550)
- Double magnesium anode included with the standard equipment (only Idra DS 750 - 1000)
- Insulation through separated packaging (only Idra DS 750 - 1000)

**SOLAR CYLINDER WITH INCREASED COIL SURFACE**

CODE	MODEL	DIMENSIONS H x Ø (mm)	CYLINDER CAPACITY (litres)	LOSSES (W)	CLASS
<b>DOUBLE COIL CYLINDERS</b>					
20117881	IDRA DS 200	1338 x 604	208 double coil	62	B
20117882	IDRA DS 300	1838 x 604	301 double coil	69	B
20117883	IDRA DS 430	1644 x 755	430 double coil	75	B
20117884	IDRA DS 550	1988 x 755	551 double coil	85	-
20132278	IDRA DS 750	1846 x 1000	731 double coil	94	-
20132281	IDRA DS 1000	2171 x 1000	883 double coil	101	-

## IDRA DS - WITH INCREASED COIL SURFACE

### ACCESSORIES

CODE	DESCRIPTION
20119911	1.5 kW Single-phase flanged electrical resistance kit (only Idra DS 200 - 550)
20119912	2.2 kW Single-phase flanged electrical resistance kit (only Idra DS 200 - 550)
20119913	3 kW Single-phase flanged electrical resistance kit (only Idra DS 200 - 550)
20119914	3.8 kW Three-phase flanged electrical resistance kit (only Idra DS 200 - 550)
20131666	1.5 kW single-phase flanged electrical resistance kit (only Idra DS 750 - 1000)
20131667	2.2 kW single-phase flanged electrical resistance kit (only Idra DS 750 - 1000)
20131669	3 kW single-phase flanged electrical resistance kit (only Idra DS 750 - 1000)
20131670	3.8 kW three-phase flanged electrical resistance kit (only Idra DS 750 - 1000)
20020778	1" thermostatic mixing valve with 3/4" adapter
20123849	Bend kit for the recirculation
20123850	Cylinder thermometer kit
20055206	1/2" Electrical anode kit <sup>(1)</sup>
20123851	Bend kit for the electrical anode <sup>(2)</sup>

(1) With electrical plug, to connect the electrical anode kit to the EVOSOL solar control box, provide a reduction from 1"¼ to ½" (not supplied as standard).

(2) Necessary in case of recirculation system only.

#### NOTE

The sacrificial magnesium anode should be periodically monitored and replaced.

Beretta strongly recommend to connect the tanks to the electrical earth of the plant.

# Solar cylinders

## IDRA DS - WITH INCREASED COIL SURFACE

IDRA DS 200-300-430-550

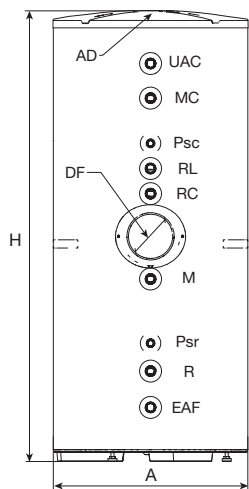

### BOILER

MC Flow  
RC Return

### SOLAR

M Flow  
R Return

UAC DHW outlet  
RL DHW recirculation  
EAF(SB) Domestic cold water inlet  
Psc Boiler probe socket  
Psr Solar control-box probe socket  
AD Magnesium anode  
DF Flange internal diameter

## TECHNICAL SPECIFICATIONS

DESCRIPTION	U.O.M.	IDRA DS 200	IDRA DS 300	IDRA DS 430	IDRA DS 550
Cylinder capacity	l	208	301	430	551
Cylinder diameter with insulation <sup>(A)</sup>	mm	604		755	
Height with insulation <sup>(H)</sup>	mm	1338	1838	1644	1988
Flange internal diameter	mm	130			
Insulation thickness	mm	50			
Probe sockets diameter / length	mm	16 / 180			
Cylinder / coils max working pressure	bar	10 / 10			
Upper coil continuous efficiency (Flow coil temperature 80°C with ΔT 20°C)	kW	16.1	23	31.4	31.4
Lower coil water content	l	3.5	5.0	7.0	9.0
Upper coil water content	l	3.5	4.0	5.0	5.0
Lower coil exchange surface	m <sup>2</sup>	0.7	1.0	1.4	1.8
Upper coil exchange surface	m <sup>2</sup>	0.7	0.8	1.0	1.0
Net weight	kg	86	108	146	171

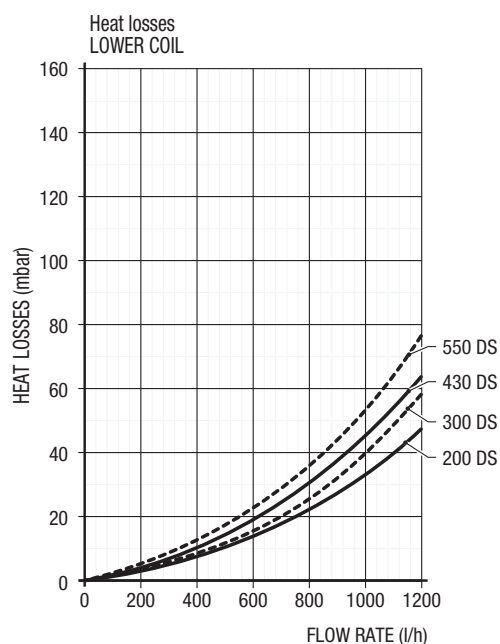
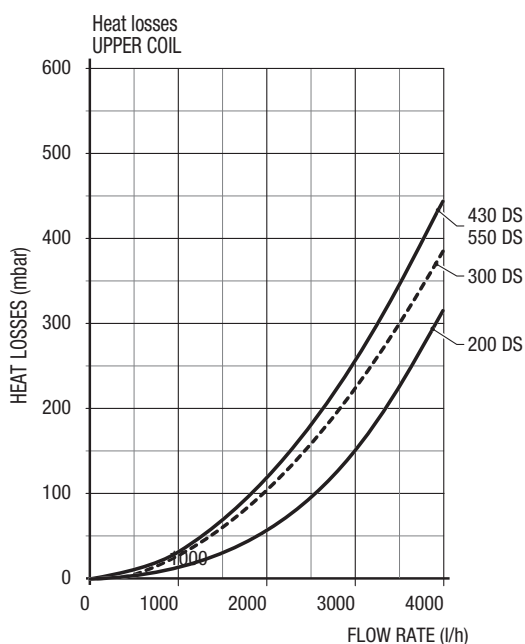

# IDRA DS - WITH INCREASED COIL SURFACE

IDRA DS 750-1000

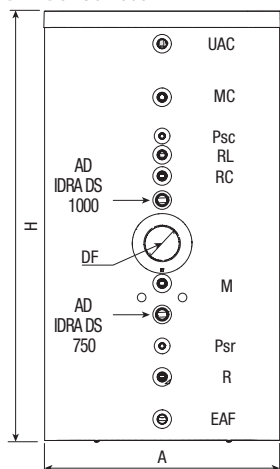

**BOILER**

- MC Flow
- RC Return

**SOLAR**

- M Flow
- R Return

- UAC DHW outlet
- RL DHW recirculation
- EAF(SB) Domestic cold water inlet
- Psc Boiler probe socket
- Psr Solar control-box probe socket
- AD Magnesium anode
- DF Flange internal diameter

## TECHNICAL SPECIFICATIONS

DESCRIPTION	U.O.M.	IDRA DS 750	IDRA DS 1000
Cylinder capacity	l	731	883
Cylinder diameter with insulation <sup>(A)</sup>	mm	1000	
Height with insulation <sup>(H)</sup>	mm	1846	2171
Flange internal diameter	mm	130	
Insulation thickness	mm	100	
Probe sockets diameter/length	mm	16/180	
Cylinder / coils max working pressure	bar	7 / 7	
Upper coil continuous efficiency (Flow coil temperature 80°C with ΔT 20°C)	kW	50	50
Lower coil water content	l	11.5	13.5
Upper coil water content	l	8.0	
Lower coil exchange surface	m <sup>2</sup>	2.3	2.7
Upper coil exchange surface	m <sup>2</sup>	1.6	
Heat loss (according to EN 12897/2006 <sup>(*)</sup> )	W	94	101
Net weight	kg	222	245

(\*) At ΔT = 45°C, ambient 20°C and storage at 65°C.

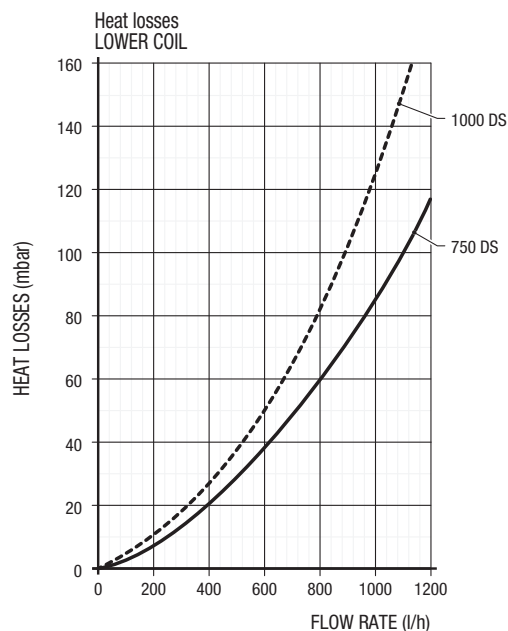
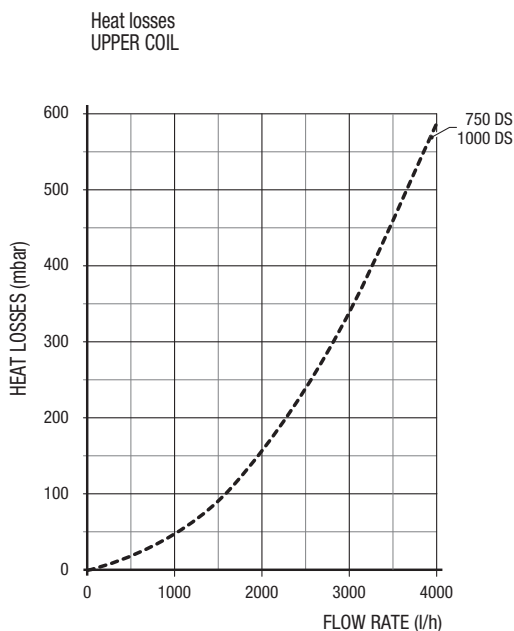

**IDRA PLUS DS - FLANGED WITH HIGH STORAGE CAPACITY**

- Enamelled steel solar cylinder with flanges.
- Maximum working temperature 99 °C.
- Possibility to insert up to 3 coils.
- Coils kit with high heat exchanger capacity (accessories).
- Suitable for electrical resistance.
- Double magnesium anode included with the standard equipment.

**FLANGED CYLINDERS WITH HIGH STORAGE CAPACITY**

CODE	MODEL	DIMENSIONS with insulation H x Ø (mm)	CYLINDER CAPACITY (litres)	HEAT LOSS (W)
20136280	IDRA PLUS DS 1000	2205 x 990	955 three flanges	142
20136282	IDRA PLUS DS 1500	2185 x 1200	1430 three flanges	162
20136285	IDRA PLUS DS 2000	2470 x 1300	1990 three flanges	186
20052796	IDRA PLUS DS 3000	2680 x 1450	2959 three flanges	344

Cylinders are supplied with flanges but without coils. To select the right coils consult the section below "Specific accessories".  
For EXPANSION VESSELS see the dedicated section "ACCESSORIES FOR SOLAR THERMAL".

**ACCESSORIES**

CODE	DESCRIPTION
20055205	Tin coated copper coil kit 2.63 m <sup>2</sup> - 53kW - 1.74L - 10bar
4383089	Tin coated copper coil kit 4.54 m <sup>2</sup> - 91kW - 3.56L - 10bar
4383087	Tin coated copper coil kit 6.34 m <sup>2</sup> - 127kW - 5.10L - 10bar*
20055206	Electrical anode kit 1/2"***
20120499	Solar control box EVOSOL with probes
20020778	1" thermostatic mixing valve with 3/4" adapter
4383272	Single-phase electrical resistance 3 kW, 1" 1/2
20079908	Single-phase electrical resistance 6.0 kW, 1" 1/2

# IDRA PLUS DS - FLANGED WITH HIGH STORAGE CAPACITY

CODE	DESCRIPTION
20020707	Three-phase electrical resistance 3.8 kW, 1" 1/2
20099595	Solar control box SUN 5 PRO 5 RS with probes

- (1) Not suitable for IDRA PLUS DS 1000.
- (2) To connect the electrical anode kit, provide a reduction (not supplied as standard) from 1" ¼ to ½".

**NOTE**  
The sacrificial magnesium anode should be periodically monitored and replaced. Beretta strongly recommend to connect the tanks to the electrical earth of the plant.

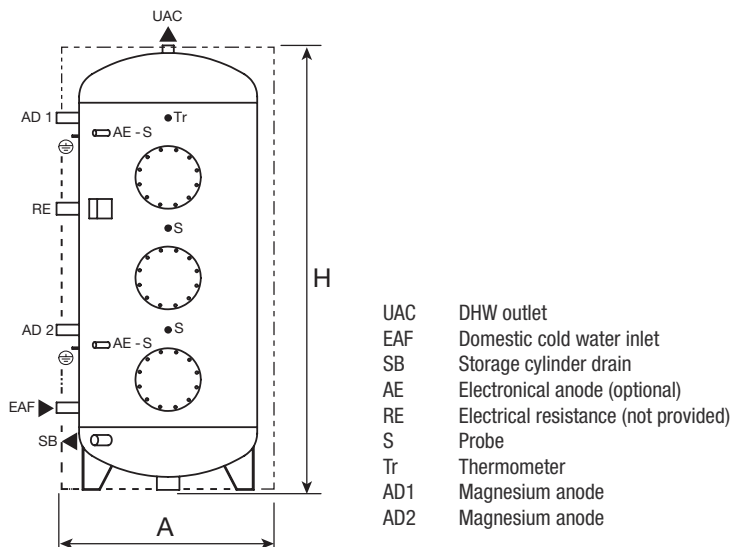

## TECHNICAL SPECIFICATIONS

	U.O.M.	IDRA PLUS DS 1000	IDRA PLUS DS 1500	IDRA PLUS DS 2000	IDRA PLUS DS 3000
Heat-exchangers lay-out		Horizontal			
Cylinder capacity	l	955	1430	1990	2959
Cylinder diameter with insulation (A)	mm	990	1200	1300	1450
Cylinder diameter without insulation	mm	790	1000	1100	1250
Height with insulation (H)	mm	2205	2185	2470	2680
Insulation thickness	mm	100			
First magnesium anode (diameter/length)	mm	32x700			
Second magnesium anode (diameter/length)	mm	-	32x400	32x700	
Flange diameter	mm	290/220			
Probes sockets diameter/length	mm	8/200			
Electrical resistor (not provided) socket	∅	1" 1/2			
Cylinder maximum working pressure	bar	10	8		
Heat loss (according to EN 12897/2006 (*)	kWh/24h	3.408	3.888	4.465	8.26
Net weight	kg	190	305	325	543

(\*) At  $\Delta T = 45^\circ C$ , ambient  $20^\circ C$  and storage at  $65^\circ C$ .

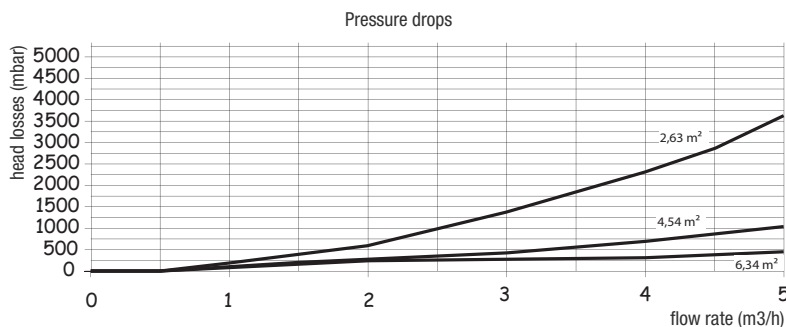

**IDRA N DS - WITH HIGH STORAGE CAPACITY**

- Vertical steel enamelled solar cylinder.
- Maximum working temperature 99 °C.
- Double coil heat-exchanger.
- High heat exchange capacity of the coils.
- Suitable for electrical resistance.
- Double magnesium anode included with the standard equipment.

**DOUBLE COIL CYLINDER WITH HIGH STORAGE CAPACITY**

CODE	MODEL	DIMENSIONS with insulation H x Ø (mm)	CYLINDER CAPACITY (litres)	HEAT LOSS (W)
20136241	IDRA N DS 1500	2185 x 1200	1390 double coil	162
20136242	IDRA N DS 2000	2470 x 1300	1950 double coil	186
20086803	IDRA N DS 2600	2455 x 1450	2572 double coil	-

For EXPANSION VESSELS see the dedicated section "ACCESSORIES FOR SOLAR THERMAL".

**ACCESSORIES**

CODE	DESCRIPTION
20120499	Solar control box EVOSOL with probes
20020778	1" thermostatic mixing valve with 3/4" adapter
20099595	Solar control box SUN 5 PRO 5 RS with probes
20079908	Single-phase electrical resistance 6 kW, 1" 1/2
4383270	Single-phase electrical resistance 1.5 kW, 1" 1/2
4383271	2,2 kW Single-phase electrical resistance 1" 1/2
20055206	Electrical anode kit 1/2" (*)
4383272	Single-phase electrical resistance 3 kW, 1" 1/2
20020707	Three-phase electrical resistance 3.8 kW, 1" 1/2

(\*) To connect the electrical anode kit, provide a reduction (not supplied as standard) from 1" ¼ to ½".

NOTE  
The sacrificial magnesium anode should be periodically monitored and replaced.  
Beretta strongly recommend to connect the tanks to the electrical earth of the plant.

# IDRA N DS - WITH HIGH STORAGE CAPACITY

## IDRA N DS 1500 - 2000

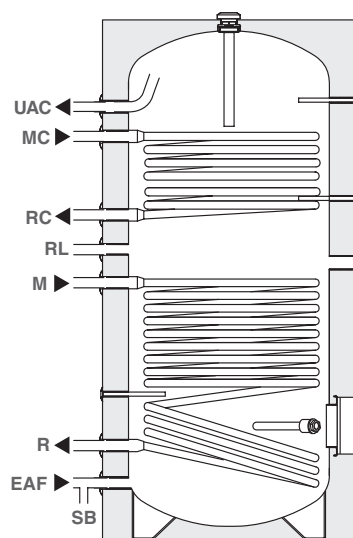
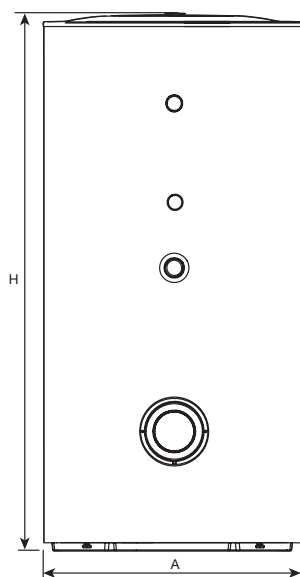

**BOILER**

MC Flow  
RC Return

**SOLAR**

M Flow  
R Return

UAC DHW outlet  
RL DHW recirculation  
EAF (SB) Domestic cold water inlet  
SB Cylinder drain

### TECHNICAL SPECIFICATIONS

DESCRIPTION	U.O.M.	IDRA N DS 1500	IDRA N DS 2000	IDRA N DS 2600
Cylinder capacity	l	1390	1950	2572
Cylinder diameter with insulation (A)	mm	1200	1300	1450
Cylinder diameter without insulation	mm	1000	1100	1250
Height with insulation (H)	mm	2185	2470	2455
Insulation thickness	mm		100	
Probes socket diameter	mm		8	
Lower coil water content	l	19.4	28.1	28.4
Upper coil water content	l	10.4	16.9	20.3
Lower coil exchange surface	m <sup>2</sup>	3.4	4.6	4.6
Upper coil exchange surface	m <sup>2</sup>	1.8	2.8	3.3
Lower coil absorbed power (*)	kW	88	120	110
Upper coil absorbed power (*)	kW	47	73	79
Heat loss (according to EN 12897/2006 (**))	kWh/24h	3.89	4.46	-
Cylinder maximum working pressure	bar		8	
Coil maximum working pressure	bar		10	6
Net weight with insulation	kg	325	540	600

(\*) With  $\Delta T = 20^\circ C$  (80/60°C) on coil.

(\*\*) At  $\Delta T = 45^\circ C$ , ambient  $20^\circ C$  and storage at  $65^\circ C$ .

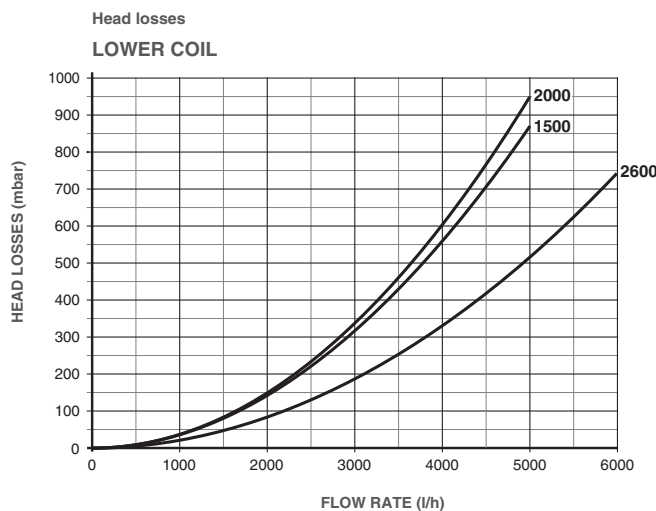
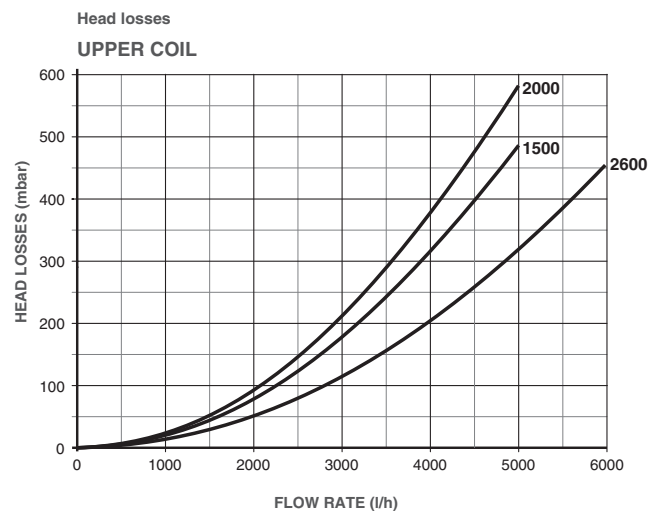



- Enamelled DHW tank, ideal to be matched with Beretta wall-hung boilers R.A.I./R.S.I. ('only heating' models).
- Supplied with high thermal-exchange coil.
- Wide range to meet all DHW needs.
- Magnesium anode supplied as standard.
- Double magnesium anode supplied as standard on BV 1000 model.



## SINGLE COIL DHW TANK

CODE	MODEL	DIMENSIONS with insulation H x Ø (mm)	CYLINDER CAPACITY (litres)	HEAT LOSS (W)*	Energy efficiency class
20101895	IDRA BV 200	1330x605	210	58	B
20101897	IDRA BV 300	1830x605	304	68	B
20101899	IDRA BV 430	1630x755	444	73	B
20101900	IDRA BV 550	1980x755	556	84	B
20101901	IDRA BV 800	1835x1000	735	93	B
20101902	IDRA BV 1000	2165x1000	890	98	B

## ACCESSORIES

CODE	DESCRIPTION
1220599	Socket probe for DHW tank
1150529	¾" Mixing valve
20020778	1" thermostatic mixing valve with ¾" adapter
4383052	DHW expansion vessel 18 litres
4383053	DHW expansion vessel 24 litres
4383054	DHW expansion vessel 35 litres

IDRA BV

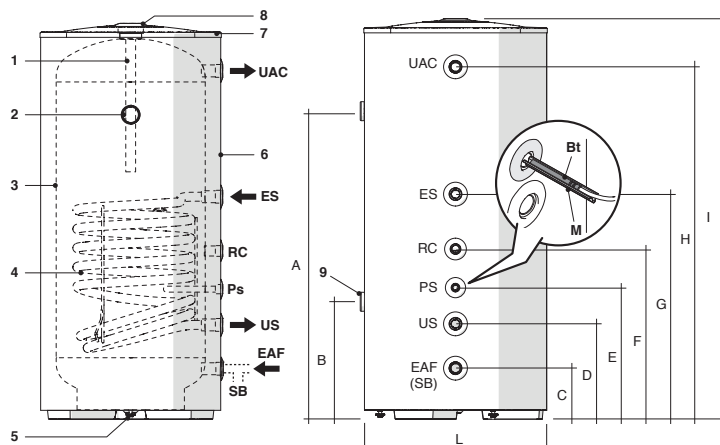

STRUCTURE	
	DESCRIPTION
1	Magnesium anode
2	Thermometer
3	Heater
4	Coil
5	Adjustable foot
6	Insulation
7	Cover
8	Cap for anode inspection and handling
9	Cap for second anode inspection
Bt	Heater or PROBE heater THERMO-STAT BULB
M	Spring

DIMENSIONS AND CONNECTIONS

DESCRIPTION	U.O.M.	IDRA BV 200	IDRA BV 300	IDRA BV 430	IDRA BV 550	IDRA BV 800	IDRA BV 1000
UAC - Domestic hot water outlet	∅	1" F		1" 1/4 M			
ES - Exchanger inlet	∅	1" F		1" 1/4 F			
RC - Domestic water recirculation	∅	3/4" F		1" M			
US - Exchanger outlet	∅	1" F		1" 1/4 F			
CWI (HD) - Domestic cold water inlet (heater drain)	∅	1" F		1" 1/4 M			
Ps - Probe pocket	∅/L	16/175					

	U.O.M.	IDRA BV 200	IDRA BV 300	IDRA BV 430	IDRA BV 550	IDRA BV 800	IDRA BV 1000	
A	mm	1025	1495	1305	1645	1470	1695	
B	mm	-						550
C	mm	170	170	205	205	75	75	
D	mm	315	315	405	405	355	355	
E	mm	435	435	555	555	600	600	
F	mm	565	805	780	780	825	910	
G	mm	745	965	1005	1005	1125	1125	
H	mm	1170	1670	1440	1785	1705	2030	
I	mm	1335	1835	1645	1990	1835	2165	
L	mm	605	605	755	755	1000	1000	

DESCRIPTION	U.O.M.	IDRA BV 200	IDRA BV 300	IDRA BV 430	IDRA BV 550	IDRA BV 800	IDRA BV 1000	
Heater type		Glazed						
Heater layout		Vertical						
Exchanger layout		Vertical						
Heater capacity	l	210	304	444	556	735	890	
Diameter/length of first magnesium anode	mm	26/500		33/450		33/520		
Diameter/length of second magnesium anode	mm	-					33/330	
Diameter/length of probe holder pockets	∅ mm	16/175						
Maximum power absorbed								
Primary circuit at 80-70°C	kW	24	34	52	52	71	71	
Primary circuit at 90-80°C	kW	33	43	66	66	94	94	
Coil water content	l	4.8	6.9	9.8		16.3		
Coil exchange surface	m <sup>2</sup>	0.78	1.13	1.49		2.47		
Production of domestic water (Δ T 35°C)								
Primary circuit at 80°C	l/h	590	831	1260	1260	1700	1700	
Primary circuit at 90°C	l/h	810	1070	1600	1600	2300	2300	
Maximum coil operating pressure	bar	10						
Specific output in 10 minutes	l/min	35	50	66	75	100	135	
Heat dispersion	W	58	68	73	84	93	98	
Maximum heater operating pressure	bar	10				7		
Maximum operating temperature	°C	99						
Net weight with insulation	kg	68	91	121	142	182	207	
Energy efficiency class		B	B	B	B	B	B	



Single coil DHW cylinders

## IDRA C-HP MS



- Cylinder suitable for pairing with boilers and heat pumps.
- Vertical single coil glazed cylinder.
- Energy class B
- It's possible to fix a removable coil (optional) for the combination with a solar system.
- It's possible to fix a electrical resistance (optional) as back up.
- Magnesium anode included as standard.
- Maximum working temperature 99 °C.
- Coils maximum working pressure: 10 bar. (only 150 - 500)
- Coils maximum working pressure: 7 bar. (only 800 - 1000)
- Insulation through separated packaging (only 800 - 1000)



### DHW TANKS IDEAL FOR HEAT PUMPS

CODE	MODEL	DIMENSIONS with insulation H x Ø (mm)	CYLINDER CAPACITY (litres)	HEAT LOSS (W)*	Energy efficiency class
20204198	IDRA C-HP 150 MS	1138 x 604	170 single coil	55	B
20204200	IDRA C-HP 200 MS	1354 x 604	210 single coil	58	B
20204202	IDRA C-HP 300 MS	1838 x 604	305 single coil	68	B
20204204	IDRA C-HP 500 MS	1793 x 755	500 single coil	84	B
20204206	IDRA C-HP 800 MS	1835 x 974	735 single coil	94	-
20204208	IDRA C-HP 1000 MS	2155 x 974	890 single coil	101	-

(\*) According to EN 12897:2006, Dt = 45 °C (outdoor temperature 20 °C, storage temperature 65 °C).

## IDRA C-HP MS

### RECOMMENDED COMBINATIONS - HEATER AND HEAT PUMP

HEATER		HEAT PUMP HYDRO UNIT P								
CODE	MODEL	004		006	008	010	012	014	012 T	014 T
		20198671	20198672	20198675	20198676	20198677	20198679	20198681	20198682	
20204198	IDRA C-HP 150 MS	•	•							
20204200	IDRA C-HP 200 MS	•	•	•						
20204202	IDRA C-HP 300 MS	•	•	•	•	•			•	
20204204	IDRA C-HP 500 MS			•	•	•	•	•	•	•
20204206	IDRA C-HP 800 MS						•	•	•	•
20204208	IDRA C-HP 1000 MS									

(\*) Flow temperature to the coil 50 °C ΔT 5 °C with DHW 10-45°C.

For the correct sizing of the heater, please refer to the technical data in the product data sheets.

HEATER			HEAT PUMP HYDRO UNIT M												
CODE	MODEL	Continuous domestic water output (kW)*	M 004	M 006	M 008	M 010	M 012	M 014	M 016	M 012 T	M 014 T	M 016 T	M 018 T	M 022 T	M 026 T
			20191950	20191951	20191952	20191953	20191954	20191956	20191957	20191958	20191959	20191960	20194173	20194174	20194175
20204198	IDRA C-HP 150 MS	6	•	•											
20204200	IDRA C-HP 200 MS	9	•	•	•										
20204202	IDRA C-HP 300 MS	12	•	•	•	•	•			•					
20204204	IDRA C-HP 500 MS	16			•	•	•	•	•	•	•	•			
20204206	IDRA C-HP 800 MS	19					•	•	•	•	•	•	•		
20204208	IDRA C-HP 1000 MS	25							•			•	•	•	•

(\*) Flow temperature to the coil 50 °C ΔT 5 °C with DHW 10-45°C.

For the correct sizing of the heater, please refer to the technical data in the product data sheets.

HEATER		HEAT PUMP EXCLUSIVE AGILE M									
CODE	MODEL	M 004	M 006	M 008	M 010	M 012	M 014	M 016	M 012 T	M 014 T	M 016 T
		20205784	20205786	20205788	20205791	20205793	20205800	20205802	20205804	20205806	20205809
20204198	IDRA C-HP 150 MS	•	•								
20204200	IDRA C-HP 200 MS	•	•	•							
20204202	IDRA C-HP 300 MS	•	•	•	•	•			•		
20204204	IDRA C-HP 500 MS			•	•	•	•	•	•	•	•
20204206	IDRA C-HP 800 MS					•	•	•	•	•	•
20204208	IDRA C-HP 1000 MS							•			•

**ACCESSORIES**

CODE	DESCRIPTION
20119911	1.5 kW Single-phase flanged electrical resistance kit (only 150 - 500) <sup>(1)</sup>
20119912	2.2 kW Single-phase flanged electrical resistance kit (only 150 - 500) <sup>(1)</sup>
20119913	3 kW Single-phase flanged electrical resistance kit (only 150 - 500) <sup>(1)</sup>
20119914	3.8 kW Three-phase flanged electrical resistance kit (only 150 - 500) <sup>(1)</sup>
20131666	1.5 kW single-phase flanged electrical resistance kit (only 800 - 1000) <sup>(1)</sup>
20131667	2.2 kW single-phase flanged electrical resistance kit (only 800 - 1000) <sup>(1)</sup>
20131669	3 kW single-phase flanged electrical resistance kit (only 800 - 1000) <sup>(1)</sup>
20131670	3.8 kW three-phase flanged electrical resistance kit (only 800 - 1000) <sup>(1)</sup>
20020778	1" thermostatic mixing valve with 3/4" adapter
20123850	Cylinder thermometer kit
20123849	Bend kit for the recirculation
20055206	Electrical anode kit 1/2"
20123851	Bend kit for electrical anode
4383270	1,5 kW Single-phase electrical resistance 1" 1/2
4383271	2,2 kW Single-phase electrical resistance 1" 1/2
4383272	3 kW Single-phase electrical resistance 1" 1/2
20020707	3.8 kW Three-phase electrical resistance 1" 1/2
20079908	6 kW Single-phase electrical resistance 1" 1/2
20203248	Solar heat exchanger 0,8m <sup>2</sup> for C-HP 150-300
20203246	Solar heat exchanger 1,2m <sup>2</sup> for C-HP 500
20203245	Solar heat exchanger 1,9m <sup>2</sup> for C-HP 800-1000

(1) The flange resistance kit is incompatible with the solar exchanger kit. If you wish to install both the solar exchanger and the resistance, you must use the resistances on the 1"1/2 hole.

**IDRA C-HP MS**

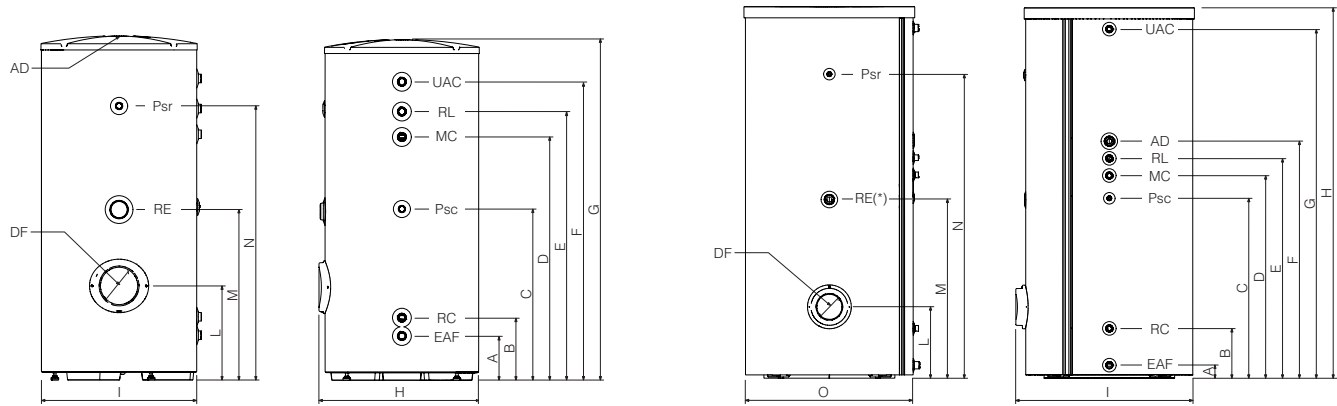

UAC Domestic hot water outlet  
 MC Flow  
 RC Return  
 RL Domestic recirculation  
 EAF Domestic cold water inlet

Psc Boiler sensor well  
 Psr Solar regulator sensor well  
 AD Magnesium anode  
 DF Flange internal diameter  
 RE Sleeve for electric resistance

DESCRIPTION		150 ms	200 ms	300 ms	500 ms	800 ms	1000 ms
Buffer tank capacity	l	170	210	305	500	735	890
External diameter with insulation <sup>(1)</sup>	mm	604	604	604	755	974	974
Height with insulation <sup>(2)</sup>	mm	1138	1354	1838	1793	1835	2155
Insulation thickness	mm	52	52	52	52	92	92
Diameter and length of probe sockets	mm	16/180					
Coil water content	l	4,25	6,9	8,5	18,9	21	24,4
Coil heat-exchange surface	m <sup>2</sup>	0,85	1,38	1,7	2,2	2,5	2,9
Tank maximum working pressure	bar	10	10	10	10	7	7
Coil maximum working pressure	bar	10	10	10	10	7	7
Net weight	kg	62	78	103	150	203	225

**DIMENSIONS AND CONNECTIONS**

DESCR.		150 MS	200 MS	300 MS	500 MS	800 MS	1000 MS
UAC	Ø	1" Gas M			1" 1/4 Gas M		
AD	mm	1/33/300	1/33/450	1/40/480	1/40/600		1/40/750
DF	mm	130					
Psr	Ø	16/180					
RE	Ø	1" 1/2 F					
RL	Ø	1" Gas M					
MC	Ø	1" Gas M					
Psc	mm	16/180					
RC	Ø	1" Gas M					
EAF	Ø	1" Gas M			1" 1/4 Gas M		

DESCR.		150 MS	200 MS	300 MS	500 MS	800 MS	1000 MS
A	mm	171	174	174	207	75	75
B	mm	243	246	256	303	289	289
C	mm	588	673	928	898	884	1047
D	mm	753	956	1041	1113	1089	1179
E	mm	836	1056	1141	1213	1189	1279
F	mm	970	1189	1673	1589	1294	1379
G	mm	1138	1354	1838	1793	1706	2032
H	mm	626	630	634	786	1831	2156
I	mm	604	604	604	755	1035	1040
L	mm	363	366	369	413	414	414
M	mm	578	663	918	888	876	1037
N	mm	813	1066	1566	1468	1440	1764
O	mm	-	-	-	-	970	973

**IDRA C-HP MS**

**SYSTEM EXAMPLES**

**SYSTEM EXAMPLES MONOVALENT HEATING, COOLING AND DHW PRODUCTION SYSTEM COMBINED WITH HEAT PUMP**

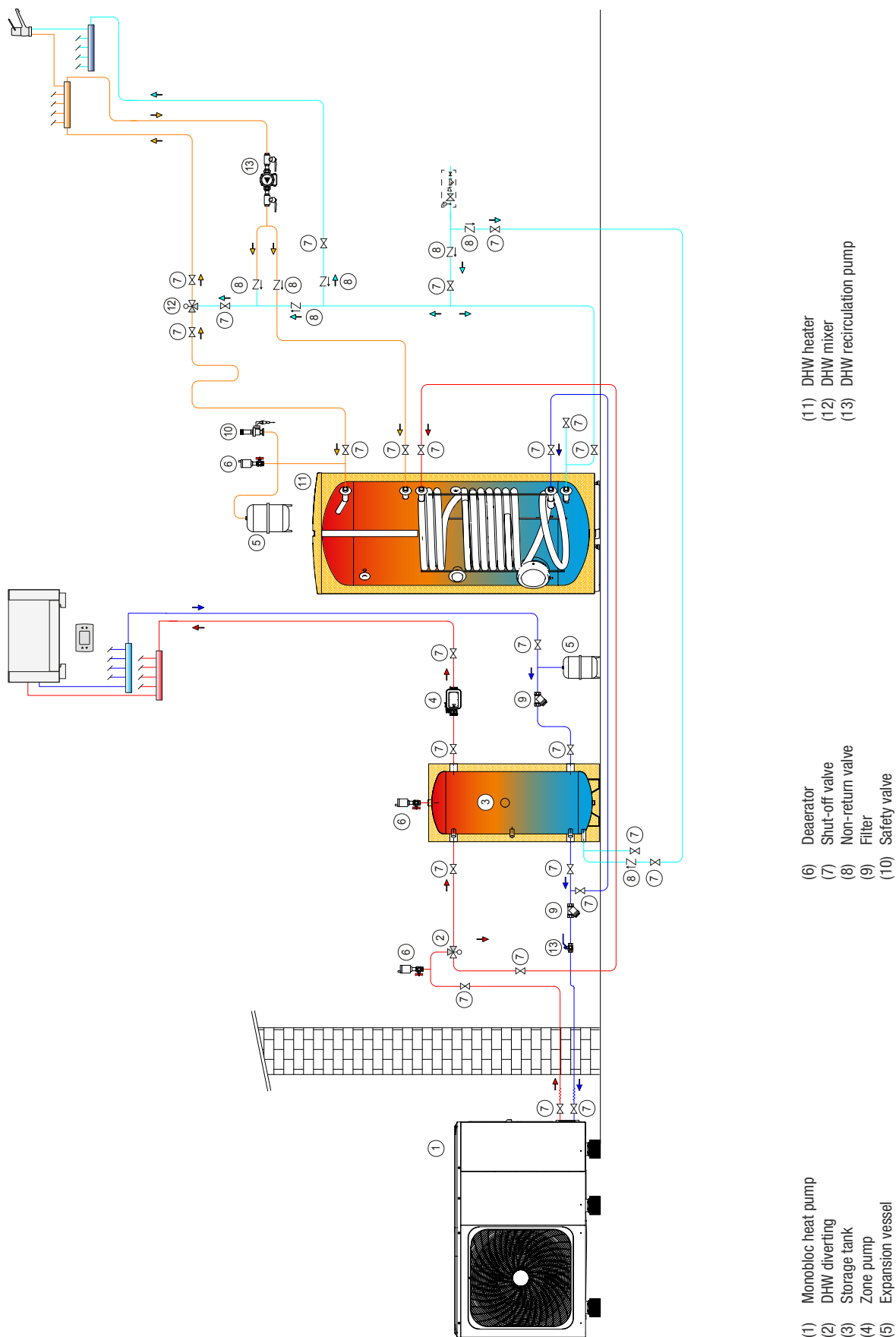



DHW tanks

## IDRA HP - FOR HEAT PUMPS AND SOLAR THERMAL



- Vertical storage tank in vitrified steel for DHW production.
- Ideal for application with heat pumps thanks to the increased surface of the coil heat-exchanger.
- Flange for solar coil heat-exchanger kit (available as option).
- Maximum working temperature 99 °C.
- Coils maximum working pressure: 6 bar.
- Suitable for electrical resistance.
- Magnesium anode included as standard.



### DHW TANKS IDEAL FOR HEAT PUMPS

CODE	MODEL	DIMENSIONS with insulation H x Ø (mm)	CYLINDER CAPACITY (litres)	HEAT LOSS (W)	INSULATION CLASS
20117745	IDRA HP 300	1615 x 600	263 single coil	85	C
20117746	IDRA HP 500	1690 x 750	475 single coil	112	C

### ACCESSORIES

CODE	DESCRIPTION
4383270	Single-phase electrical resistance 1.5 kW, 1" 1/2
4383272	Single-phase electrical resistance 3 kW, 1" 1/2
20020778	1" thermostatic mixing valve with 3/4" adapter
4383504	Solar coil heat exchanger kit for IDRA HP 300
4383505	Solar coil heat exchanger kit for IDRA HP 500

**NOTE**  
The sacrificial magnesium anode should be periodically monitored and replaced.  
Beretta strongly recommend to connect the tanks to the electrical earth of the plant.

## IDRA HP - FOR HEAT PUMPS AND SOLAR THERMAL

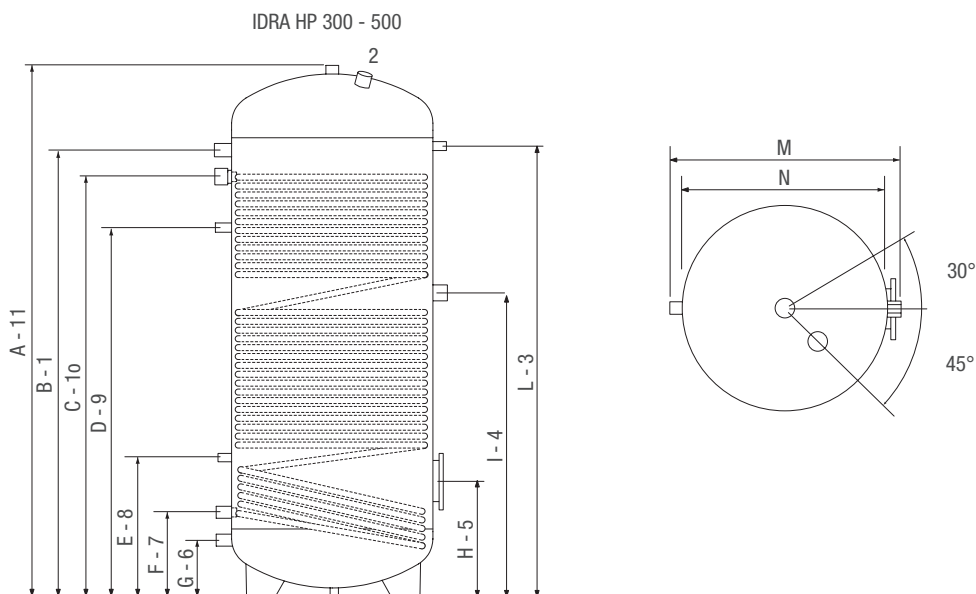

### TECHNICAL SPECIFICATIONS

DESCRIPTION	IDRA HP 300	IDRA HP 500
Tank type	-	vitrified
Tank lay-out	-	vertical
Heat exchanger lay-out	-	vertical
Coil exchange surface	m <sup>2</sup>	4
Tank maximum working pressure	bar	6
Coil water content	l	23
Coil maximum working pressure	bar	6
Coil absorbed max power (80/60°C)	kW	96
Maximum working temperature	°C	99
Insulation thickness in CFC-free expanded polyurethane	mm	50
Inspection flange diameter	Ø/mm	180/120
Empty weight	kg	119
Cylinder capacity	l	263
Heat loss (according to EN 12897/2006 (at ΔT = 45°C, ambient 20°C and storage at 65°C))	W	85
	kWh/24h	2.04
Insulation CLASS	-	C

### CONNECTIONS

DESCRIPTION	IDRA HP 300	IDRA HP 500
1 DHW OUTLET	inch 1"	inch 1"
2 Anode	inch 1 1/4"	inch 1 1/4"
3 Probe thermometer	inch 1/2"	inch 1/2"
4 Electrical resistance	inch 1 1/2"	inch 1 1/2"
5 Flange	Ø/mm 180/120	Ø/mm 180/120
6 Cold water INLET	inch 1"	inch 1"
7 Coil RETURN	inch 1"	inch 1 1/4"
8 Probe	inch 1/2"	inch 1/2"
9 Recirculation	inch 1/2"	inch 1/2"
10 Coil OUTLET	inch 1"	inch 1 1/4"
11 DHW OUTLET	inch 1 1/4"	inch 1 1/4"
(12) blind pallet connection	inch 1/2"	inch 1/2"

### DIMENSIONS

DESCRIPTION	IDRA HP 300	IDRA HP 500
A	mm 1615	mm 1690
B	mm 1390	mm 1415
C	mm 1310	mm 1325
D	mm 1165	mm 1170
E	mm 395	mm 425
F	mm 220	mm 265
G	mm 140	mm 185
H	mm 340	mm 370
I	mm 945	mm 970
L	mm 1390	mm 1425
M	mm 600	mm 750
N	mm 500	mm 650

**STOR M AND STOR - WITH COIL OR FLANGED**

- Designed for forced circulation solar systems to supplement the heating system.
- Production of DHW through an additional external heat exchange module “ACS” (see dedicated pages).
- STOR M and STOR tanks are not suitable for DHW storage.
- Tank and coil maximum working temperature: 99°C.
- Eight fittings at different heights for the use of different types of heat generators for the best stratification.
- Buffer tank and insulation are delivered in separate packages for STOR models.
- STOR M models: supplied with heat exchange solar coil and insulation as standard equipment.
- STOR models: through a standard flange it is possible the insertion of an additional heat exchange solar coil, available as accessory.

**BUFFER TANKS WITH COIL OR FLANGED**

CODE	MODEL	DIMENSIONS with insulation H x Ø (mm)	BUFFER TANK CAPACITY (litres)	HEAT LOSS (W)	CLASS
<b>BUFFER TANKS WITH COIL</b>					
20055207	STOR 300 M	1635 x 700	283 with coil	93	C
20055208	STOR 500 M	1775 x 850	489 with coil	110	C
20136264	STOR 1000 M	2190 x 990	920 with coil	143	-
20136265	STOR 1500 M	2165 x 1200	1410 with coil	167	-
<b>FLANGED BUFFER TANKS (WITHOUT COIL)</b>					
20136258	STOR 2000	2480 x 1300	2010	190	-
20001409	STOR 3000	2720 x 1450	2959	344	-
20001410	STOR 5000	2870 x 1800	5055	646	-

For EXPANSION VESSELS see the dedicated section “ACCESSORIES FOR SOLAR THERMAL”.

**ACCESSORIES**

CODE	DESCRIPTION
20055205	Tin coated copper coil kit 2.63 m <sup>2</sup> (*) - 53kW - 1.74L - 10bar
4383089	Tin coated copper coil kit 4.54 m <sup>2</sup> (*) - 91kW - 3.56L - 10bar
4383087	Tin coated copper coil kit 6.34 m <sup>2</sup> (*) - 127kW - 5.10L - 10bar

(\*) To use only with STOR 2000, STOR 3000 and STOR 5000.

N.B. Beretta strongly recommend to connect the tanks to the electrical earth of the plant.

# Buffer tanks

## STOR M AND STOR - WITH COIL OR FLANGED

**STOR M**

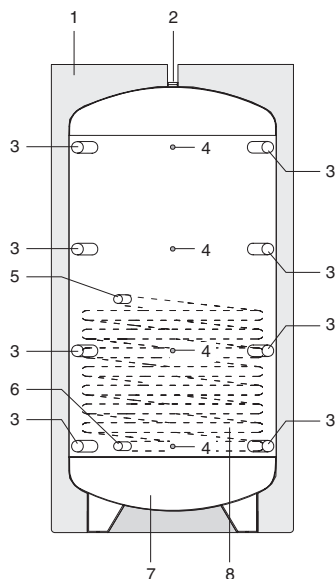

- 1 - Soft insulation (100 mm thick) in CFC-free polyurethane
- 2 - Vent/flow connection ( $\varnothing$  1"1/4F)
- 3 - Flow/return connection ( $\varnothing$  1"1/2F)
- 4 - Probes sockets ( $\varnothing$  8 mm)
- 5 - Solar collector flow connection ( $\varnothing$  1" F)
- 6 - Solar collector return connection ( $\varnothing$  1" F)
- 7 - Tank
- 8 - Coil
- 9 - Inspection flange

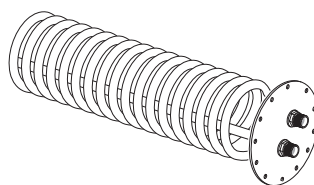

**STOR**

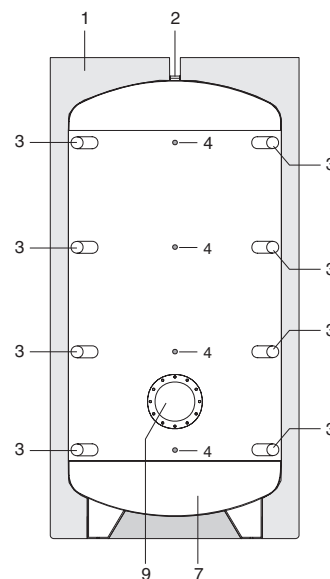

### TECHNICAL SPECIFICATIONS

SPECIFICATIONS	U.O.M.	STOR 300 M	STOR 500 M	STOR 1000 M	STOR 1500 M	STOR 2000	STOR 3000	STOR 5000
Heat-exchanger layout		Vertical				-	-	-
Buffer tank capacity	l	283	489	920	1410	2010	2959	5055
External diameter with insulation	mm	700	850	990	1200	1300	1450	1800
Height with insulation	mm	1635	1775	2190	2165	2480	2720	2870
Insulation thickness	mm	100						
Flange diameter (external/internal)	mm	-	-	-	-	290/220	290/220	290/220
Probes sockets diameter	mm	8						
Coil water content	l	10.4	10.4	14.6	21.6	-	-	-
Coil heat-exchange surface	m <sup>2</sup>	1.8	1.8	2.6	3.8	-	-	-
Coil absorbed power (*)	kW	43	45	68	99	-	-	-
Tank maximum working pressure	bar	3						
Coil maximum working pressure	bar	6	6	6	6	-	-	-
Heat loss according to EN 12897/2006 (**)	kWh/24h	2.232	2.64	3.43	4.01	4.56	8.256	15.504
Net weight with insulation	kg	115	140	180	245	290	415	570

(\*) With  $\Delta T = 20^\circ\text{C}$  (80/60°C) on coil. (\*\*) At  $\Delta T = 45^\circ\text{C}$ , ambient  $20^\circ\text{C}$  and storage at  $65^\circ\text{C}$ .

**STOR M HEAD LOSSES**

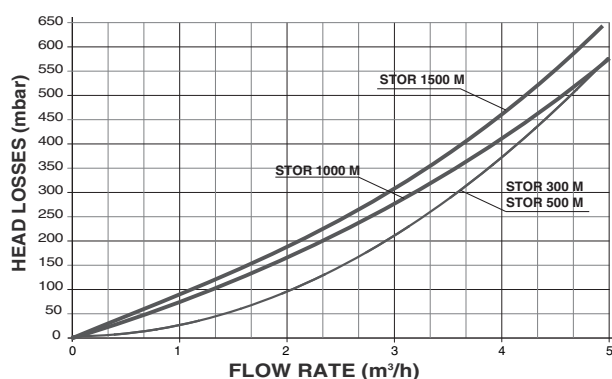

**HEAD LOSSES OF STOR EXCHANGE COIL (ACCESSORY)**

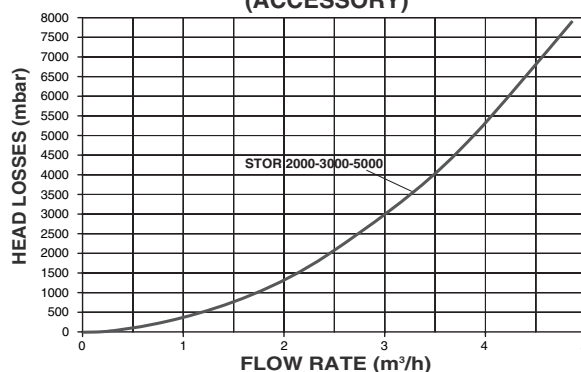



Buffer tanks for systems with heat pumps

## STOR H



- Inertial cold/hot water buffer tank, ideal to be used in systems with heat pumps, solar thermal, biomass boilers.
- It can be easily fitted into systems where Beretta boilers work as an auxiliary heat generator.
- The fittings are positioned at different heights for use in high and low temperature circuits.
- Possibility to integrate an electrical resistance.



### INERTIAL COLD/HOT WATER BUFFER TANK

CODE	DESCRIPTION	DIMENSIONS H x Ø (mm)	STORAGE VOLUME (litres)	HEAT LOSS (W)	ENERGY CLASS
20223474	STOR H 60	935 x 400	57	34	B
20223475	STOR H 120	1095 x 500	123	50	B
20056180	STOR H 200	1395 x 550	203	68	C
20056181	STOR H 300	1560 x 600	277	82	C
20056182	STOR H 400	1540 x 700	390	105	C
20056183	STOR H 500	1840 x 700	473	114	C

For EXPANSION TANKS, see the section "ACCESSORIES FOR SOLAR THERMAL SYSTEMS."

### ACCESSORIES

CODE	DESCRIPTION
4383270	Single-phase electrical resistance kit 1.5 kW, 1" 1/2
4383271	Single-phase electrical resistance kit 2.2 kW, 1" 1/2
4383272	Single-phase electrical resistance kit 3 kW, 1" 1/2
20020707	Three-phase electrical resistance kit 3.8 kW, 1" 1/2

Note: accessories not available with the STOR H 60 Model

## STOR H

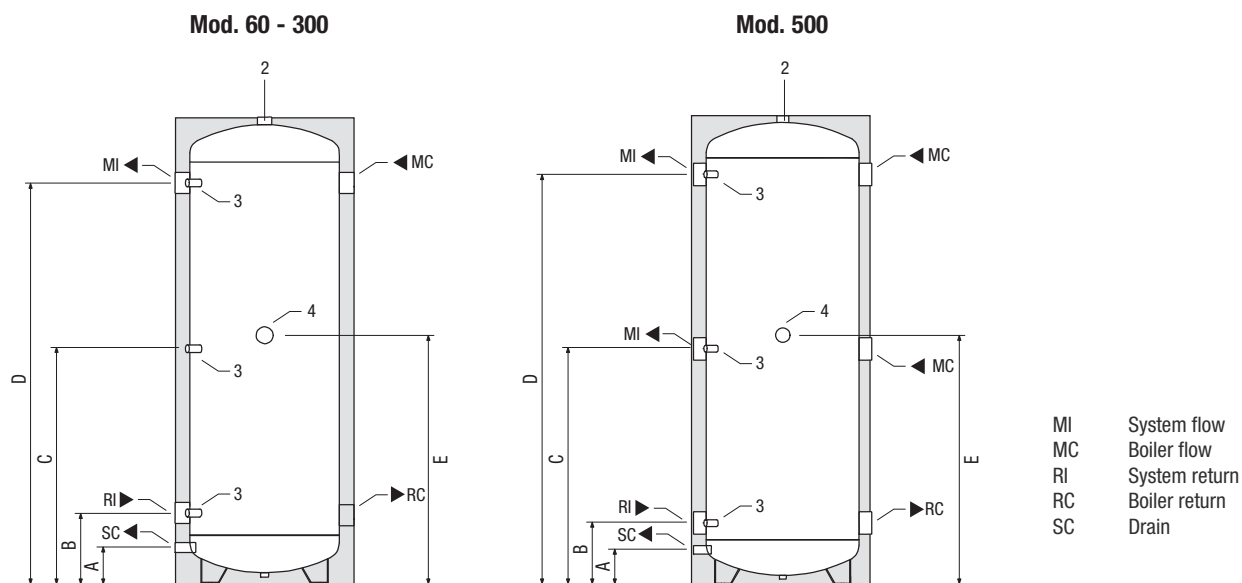

### TECHNICAL SPECIFICATIONS

STOR H								
DESCRIPTION			60	120	200	300	400	500
Buffer tank type			Not enamelled					
Buffer tank lay-out			Vertical					
Storage volume		l	57	123	203	277	390	473
External diameter with insulation		mm	400	500	550	600	700	700
Height with insulation		mm	935	1095	1395	1560	1540	1840
Insulation thickness		mm	50					
Tank maximum working pressure		bar	6					
Tank maximum working temperature		°C	99					
Heat losses		W			68	82	105	114
Net weight with insulation		kg	25	35	45	55	95	95
Gross weight (package included)		kg	-	-	64	75	116	118
Insulation (polyurethane)	1	mm	50					
Vent valve fitting	2	∅	1" 1/4 F					
Probe sockets diameter	3	∅	1/2" F					
Sleeve for electric heating element (not supplied)	4	∅	1" 1/2 F					
CH Flow	MI	∅	1" 1/4 F	1" 1/4 F	1" 1/2 F	2" F	2" 1/2 F	2" 1/2 F
CH Return	RI	∅	1" 1/4 F	1" 1/4 F	1" 1/2 F	2" F	2" 1/2 F	2" 1/2 F
Drain	SC	∅	1/2" F	1/2" F	1/2" F	3/4" F	3/4" F	3/4" F
Boiler Return	RC	∅	1" 1/4 F	1" 1/4 F	1" 1/2 F	2" F	2" 1/2 F	2" 1/2 F
Boiler Flow	MC	∅	1" 1/4 F	1" 1/4 F	1" 1/2 F	2" F	2" 1/2 F	2" 1/2 F
Height	A	mm	100	100	105	120	135	135
	B	mm	180	185	215	235	240	240
	C	mm	485	560	705	785	775	925
	D	mm	785	935	1200	1340	1310	1610
	E	mm	530	605	750	830	820	970

# SOLAR CONTROLS AND PUMP STATIONS

HYBRID SYSTEMS

HEAT PUMPS

WALL HUNG BOILERS

WATER-HEATERS

SOLAR THERMAL UNIT AND CYLINDERS

CENTRALIZED HEATING

AIR CONDITIONING

TERMINAL UNITS

SYSTEM COMPLEMENTARY ITEMS

## CONNECT SOLAR



CODE	DESCRIPTION
20116162	7.5 m CONNECT SOLAR R - only return hydraulic group <sup>(1)</sup>
20116161	7.5 m CONNECT SOLAR M/R - flow/return hydraulic group <sup>(2)</sup>
20156553	High Residual Head, Flow & Return solar hydraulic group (10 bar; 11 m) <sup>(3)</sup>
20158203	Hydraulic connections for RSS MR 14MT

(1) Only return hydraulic group for wall-mounting installation without solar control box, equipped with pump for PWM and ON/OFF management.  
 (2) Flow/return hydraulic group for wall-mounting installation, equipped with EVOSOL solar control box and PWM modulating pump.  
 (3) The group can provide high residual head for up to 35 m<sup>2</sup> of net solar collector area. Please refer to the product instruction manual for the performance group of the pump to correctly choose the pump station based on the designed flow rate of the solar thermal loop.

### USEFUL HEAD AVAILABLE

Solar delivery and return station. Values referred to a mix of water and 30% glycol.

CONNECT SOLAR R and M/R

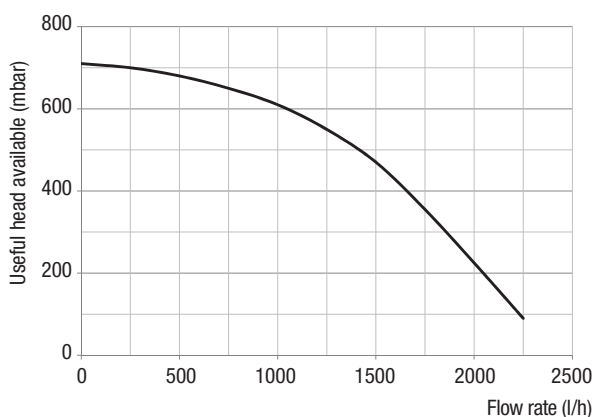

LE (head 14,5 m)

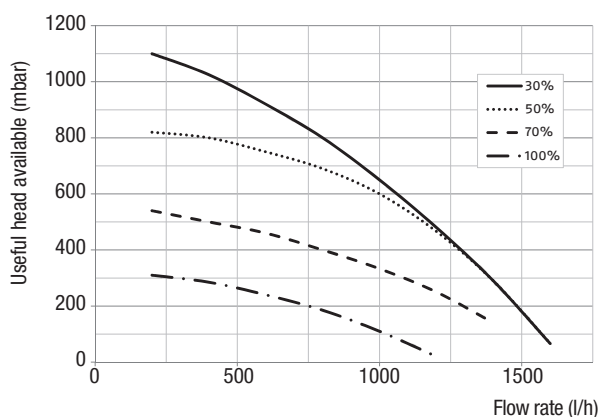

## EVOSOL



CODE	DESCRIPTION
20120499	Solar control box EVOSOL with probes

Commercial name	No. of standard output relays	No. of Inlets for probes	No. of Probes supplied	No. of configurable system layouts
EVOSOL	2	4	1x collector + 2x heaters	9

Complementary items

## SOLAR CONTROLS AND PUMP STATIONS

### SUN PRO



CODE	DESCRIPTION
20099595	Solar control box SUN 5 PRO 5 RS with probes

Commercial name	No. of standard output relays	No. of Inlets for probes	No. of Probes supplied (*)	No. of configurable system layouts
SUN 5 PRO 5 RS	5	9	2x collector + 3x heaters	7 (+ variants)

(\*) Specific probes for flat collectors.

### ACCESSORIES

CODE	DESCRIPTION
20039694	SUN 1 thermostat with boiler probes
20125097	Additional solar probe for EVOSOL and SUN 5 PRO 5 RS control unit (1)
20123856	Additional heater probe for EVOSOL and SUN 5 PRO 5 RS control unit (1)

(1) The solar control boxes are already equipped with probes



Heat exchanger units  
**SC SUN**



- Heat exchange unit on solar side
- Suitable for medium-sized solar systems
- Wall installation
- Can be used for two storages
- Effective for layering at two heights
- Solar control unit as standard
- Low-consumption circulating pumps as standard
- Electronic management of circulating pump on solar circuit
- Motorised diverting valve
- AISI 316 plate heat exchanger
- Complete with thermal insulation
- Complete with flow meter for visualisation of flow rate on storage side

**SOLAR CIRCUIT HEAT EXCHANGE UNIT - TECHNICAL WATER**

CODE	MODEL	DIMENSIONS H x W x D (mm)	MANAGEABLE COLLECTOR SURFACE (m <sup>2</sup> )
20156326	SC SUN 50	600 x 400 x 250	20 *

\* Domestic water production at 45°C, with inlet at 10°C and storage temperature at 55°C.



- Heat exchange unit on solar side
- Suitable for large solar systems
- Wall installation
- Can be used for two storages
- Effective for layering at two heights
- Solar control unit as standard
- Low-consumption circulating pumps as standard
- Electronic management (0-10 V) of circulating pump on solar circuit
- Motorised diverting valve
- Electronic flow meter for visualisation of flow rate on storage side
- Complete with thermal insulation
- AISI 316 plate heat exchanger

**SOLAR CIRCUIT HEAT EXCHANGE UNIT - TECHNICAL WATER**

CODE	MODEL	DIMENSIONS H x W x D (mm)	MANAGEABLE COLLECTOR SURFACE (m <sup>2</sup> )
20156327	SC SUN 120	840 x 480 x 220	80 (*)
<b>SOLAR CIRCUIT HEAT EXCHANGE UNIT - DOMESTIC HOT WATER</b>			
20156331	SC SUN 120 ACS	840 x 480 x 220	80 (*)

(\*) Domestic water production at 45°C, with inlet at 10°C and storage temperature at 55°C.



# Heat exchanger units

## SC ACS



- Heat exchange unit for instantaneous production of domestic hot water in small and medium solar systems
- Wall installation
- Standard control unit (SC ACS 40, SC ACS 80)
- Thermostatic mixing valve as standard (SC ACS 25, SC ACS 35)
- Electronic temperature control (SC ACS 40, SC ACS 80)
- Low return temperature on primary circuit
- Low-consumption circulating pump as standard
- AISI 316 plate heat exchanger
- Possibility of cascade installation
- Possibility of recirculation kit installation

### TECHNICAL WATER - DOMESTIC HOT WATER HEAT EXCHANGE UNIT

CODE	MODEL	DIMENSIONS H x W x D (mm)	DOMESTIC WATER PRODUCTION (*) (litres/min.)
20156322	SC ACS 25	600 x 400 x 250	19
20156324	SC ACS 35	600 x 400 x 250	28
20156325	SC ACS 40	600 x 400 x 250	38
20182669	SC ACS 80	835 x 475 x 226	60

\* Domestic water production at 45°C, with inlet at 10°C and storage temperature at 55°C.

### ACCESSORIES

CODE	DESCRIPTION
20083502	Recirculation kit SC ACS 25 and SC ACS 35 <sup>(1)</sup>
20182673	Recirculation kit SC ACS 40 <sup>(2)</sup>
20182676	Recirculation kit SC ACS 80 <sup>(3)</sup>
20182674	Cascade kit 2 x SC ACS 40 <sup>(4)</sup>
20182675	Cascade kit 3 x SC ACS 40 <sup>(4)</sup>
20182677	Cascade kit 2 x SC ACS 80 <sup>(5)</sup>
20182678	Cascade kit 3 x SC ACS 80 <sup>(5)</sup>

(1) Use only one recirculation kit both in case of single SC ACS and in case of SC ACS in cascade.

(2) Use the recirculation kit only in case of single SC ACS 40.

(3) Use the recirculation kit only in case of single SC ACS 80.

(4) SC ACS 40 cascade kit includes the recirculation kit.

(5) SC ACS 80 cascade kit includes the recirculation kit.



Heat exchanger units  
**SC ACS**



- Heat exchange unit for instantaneous production
- of domestic hot water
- Suitable for large solar systems
- Control unit as standard
- Low return temperature on primary circuit
- Two low-consumption circulating pumps as standard
- Electronic management (0-10 V) of circulating pump on solar circuit
- Modulating circulating pump for DHW recirculation
- AISI 316 plate heat exchanger

**TECHNICAL WATER - DOMESTIC HOT WATER HEAT EXCHANGE UNIT**

CODE	MODEL	DIMENSIONS H x W x D (mm)	DOMESTIC WATER PRODUCTION (*) (litres/min.)
20176021	SC ACS 160	1100 x 1000 x 469	100
20156329	SC ACS 225	1100 x 1000 x 469	150

\* Domestic water production at 45°C, with inlet at 10°C and storage temperature at 55°C.  
 Delivery time of the material if not available in stock: up to 30 working days from order validation date.  
 (5) SC ACS 80 cascade kit includes the recirculation kit.

**DIVERTER VALVES AND THERMOSTATIC VALVES**

CODE	DESCRIPTION
20020778	1" thermostatic mixing valve with 3/4" adapter
20035644	Solar diverter mixing valve kit (for combination boilers)



CODE	DESCRIPTION
20035644	Solar diverter mixing valve kit (for combination boilers) *

\* The mixing valve is not designed for installation in built-in BOXES.

**EXPANSION VESSEL**

CODE	DESCRIPTION
4383052	18 lt expansion vessel
4383053	24 lt expansion vessel
4383054	35 lt expansion vessel
1150499	Bracket for wall installation of expansion tank 18-24 liters.
4383256	50 lt expansion vessel
4383257	100 lt expansion vessel

**GLYCOL AND ACCESSORIES**

CODE	DESCRIPTION
20009190	2,5 kg glycol
4383085	5 kg glycol
4383059	10 kg glycol
20011536	Flow rate regulator 12 (DN20; 2-12 l/min; kvs=2,2 m³/h)
20026577	Manual bleed valve kit

# SYSTEM FOR DHW AND HEATING PRODUCTION WITH DOUBLE SOLAR HYDRAULIC UNIT

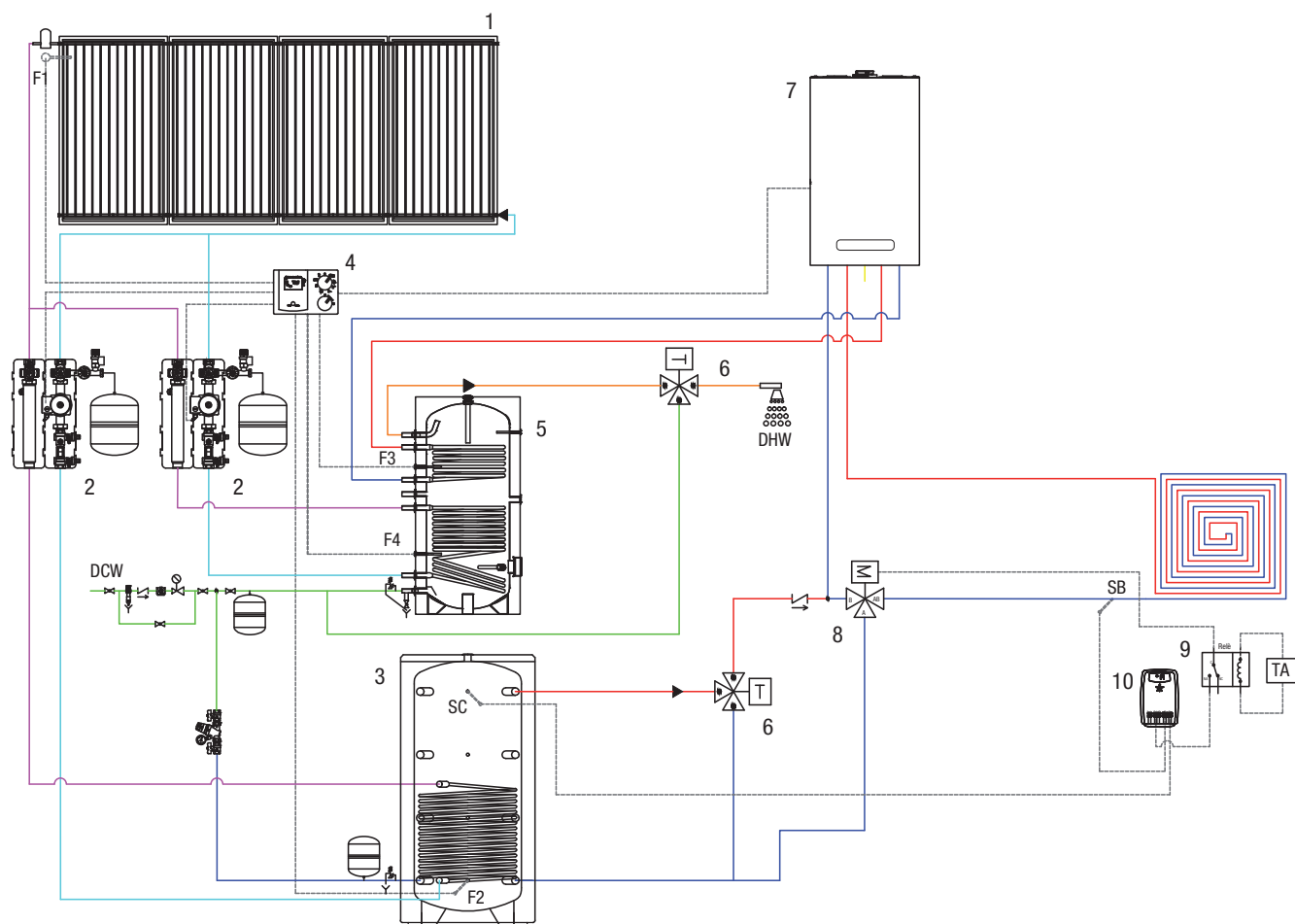

Purely indicative diagram

**Key:**

- (1) Flat solar collectors
- (2) Solar hydraulic supply and return unit
- (3) STOR single-coil buffer tank
- (4) SUN 5 solar control unit
- (5) IDRA double coil domestic hot water tank
- (6) Thermostatic mixing valve
- (7) Condensing boiler
- (8) BT system return diverter valve
- (9) Multifunction relay
- (10) SUN 1 thermostat

- F1 Solar collector sensor
- F2 Lower storage tank sensor
- F3 Upper domestic hot water tank sensor
- F4 Lower domestic hot water tank sensor
- SB Radiant panel system return sensor
- SC Upper storage tank sensor
- TA Hi, Comfort T100 chronothermostat

# SYSTEM FOR DHW PRODUCTION, HEATING, AND SWIMMING POOL WITH SINGLE COIL STORAGE

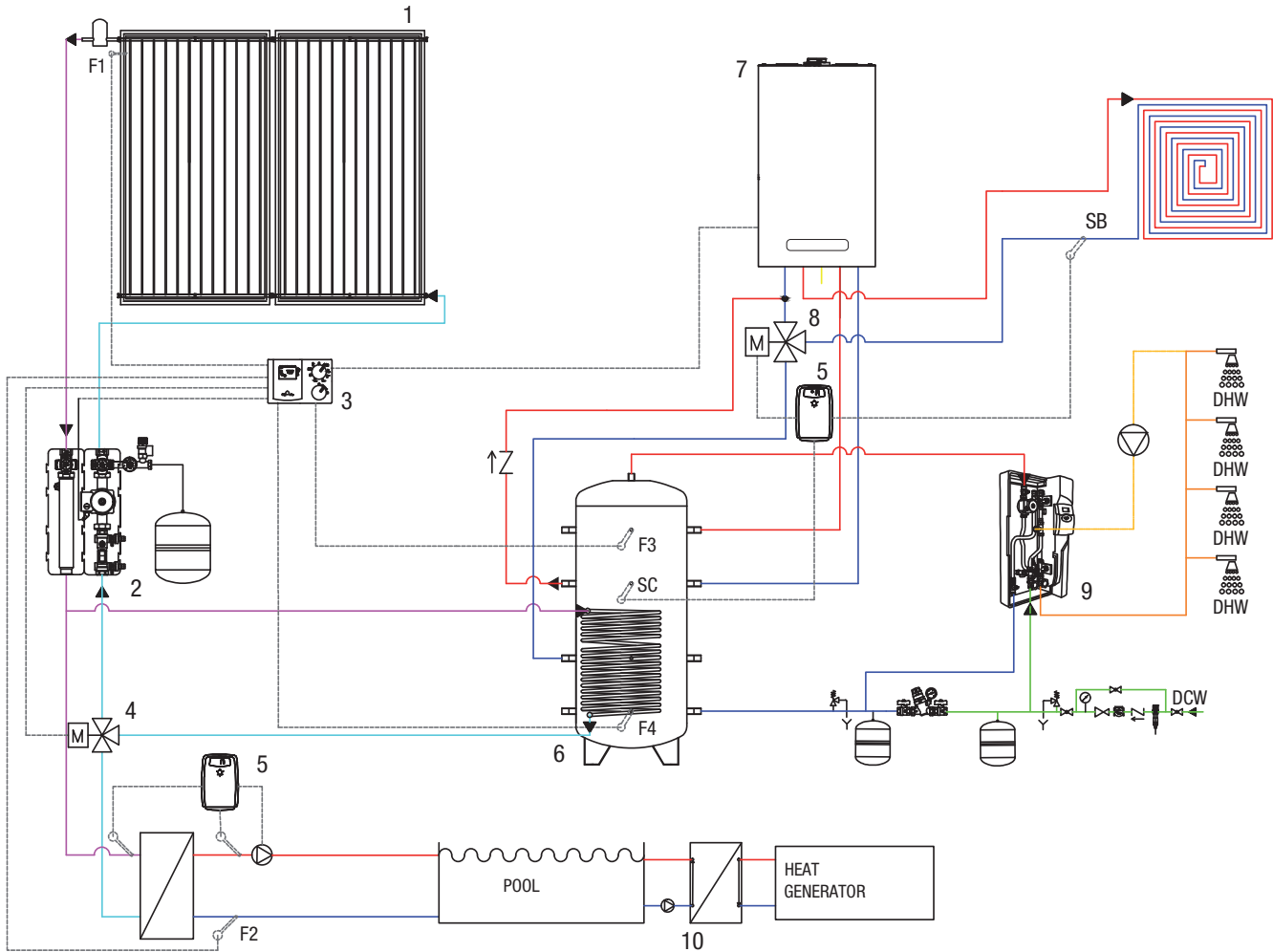

Purely indicative diagram

**Key:**

- (1) Flat solar collectors
- (2) Solar hydraulic flow and return unit
- (3) SUN 5 solar control unit
- (4) Motorized solar storage/pool diverter valve
- (5) Mains water softener
- (6) STOR M single-coil buffer tank
- (7) Condensing boiler
- (8) Motorized BT system return diverter valve
- (9) ACS 30 domestic hot water production module
- (10) SP inspectable plate heat exchanger

- F1 Solar collector sensor
- F3 Upper storage tank sensor
- F4 Lower storage tank sensor
- SB Radiant panel system return sensor
- SC Central storage tank sensor

CENTRALIZED HEATING >>

WALL HUNG MODULAR SYSTEMS	248
---------------------------	-----

FLOOR MODULAR SYSTEMS	270
-----------------------	-----

FLUE OPTION SYSTEMS	286
---------------------	-----



Modular condensing wall-hung boilers for indoor application

## POWER EVO-X



- New horizontal primary stainless steel heat exchanger
- Low pollutant emissions, class 6 (UNI EN 15502-1)
- Possibility to cascade up to 280 kW
- Possibility to install both front or back-to-back cascade system
- Designed to operate with natural gas and hydrogen mixtures, up to a maximum of 20%
- Low consumption modulating circulator with high hydraulic head
- Protection degree: IP X5D
- Maximum operating pressure: 5 bar
- Wide range of accessories available



### PREMIXED CONDENSING BOILER

CODE	LANGUAGE	MODEL	DIMENSIONS H x W x D (mm)	HEAT INPUT Min - Max (kW)	CLASS
					(D→A+++)* 
<b>ONLY HEATING</b>					
20190069	IT - EN	POWER EVO-X 50 DEP	740 x 470 x 350	5,20-34,9	A
20202734	FR				
20202735	ES - PT				
20202736	PL - HU - RO - RU				
20202737	SK - SR - GR - SI - HR				
20190070	IT - EN	POWER EVO-X 50	740 x 470 x 350	5,20-45	A
20202738	FR				
20202739	ES - PT				
20202740	PL - HU - RO - RU				
20202741	SK - SR - GR - SI - HR				
20190072	IT - EN	POWER EVO-X 65	740 x 470 x 453	8,20-55	A
20202742	FR				
20202743	ES - PT				
20202744	PL - HU - RO - RU				
20202745	SK - SR - GR - SI - HR				

## POWER EVO-X

CODE	LANGUAGE	MODEL	DIMENSIONS H x W x D (mm)	HEAT INPUT Min - Max (kW)	CLASS
					(D→A+++)* 
20190073	IT - EN	POWER EVO-X 80	740 x 470 x 453	8,20-70	A
20202746	FR				
20202747	ES - PT				
20202748	PL - HU - RO - RU				
20202749	SK - SR - GR - SI - HR				

(\*) HEATING: the energy class of the products ranges from D up to A+++

**ATTENTION:** every model is available under different codes, according to the documentation language/s of the instruction manual supplied with the product.

Please select the right code of your model according to the documentation language you need:

- IT / EN (Italian / English)
- FR (French)
- ES / PT (Spanish / Portuguese)
- PL / HU / RO / RU (Polish / Hungarian / Romanian / Russian)
- SK / CZ / GR / SI / CR (Slovak / Czech / Greek / Slovenian / Croatian)

### ACCESSORIES - STAND ALONE INSTALLATION

CODE	DESCRIPTION
<b>HYDRAULIC ACCESSORIES</b>	
20195886	Hydraulic separator/plate heat exchanger connection <sup>(1)</sup>
20195884	Horizontal hydraulic separator
20195888	Brazed plate heat exchanger kit for stand alone boiler (20 plates) <sup>(2)</sup>
20197360	Brazed plate heat exchanger kit for stand alone boiler (30 plates) <sup>(2)</sup>
20195889	Internal 3 way valve kit <sup>(3)</sup>
20195890	External 3 way valve kit <sup>(4)</sup>
20195891	Delivery/return connection for direct installation
<b>SAFETY ACCESSORIES</b>	
20195883	Safety kit manifold <sup>(5)</sup>
20199254	Safety valve 4,5 bar FF 3/4"x1" <sup>(6)</sup>
<b>MECHANICAL ACCESSORIES</b>	
20195885	Cover for safety kit/hydraulic separator
20195887	Cover for plate heat exchanger
20200070	Spacer kit for fixing to wall <sup>(7)</sup>
<b>ELECTRICAL ACCESSORIES</b>	
20207834	REC10MHC remote control <sup>(8)</sup>

(1) Suitable for the combination with safety valve cod.20199254.

(2) To be installed mandatory with cod.20196701.

(3) Suitable for 35-45 kW models.

(4) Suitable with the plate heat exchanger kit for stand alone boiler for the DHW production.

(5) Contains: thermometer, pressure gauge, safety valve, pressure switch and fuel shut-off valve.

(6) For Italian market: suitable only for 35 kW model.

(7) Kit required for rear wall concentric discharge for 55-70 kW models.

(8) Allows the management of: solar thermal and up to 3 direct/mixed independent zones.

**ACCESSORIES - CASCADE INSTALLATION**

CODE	DESCRIPTION
<b>HYDRAULIC ACCESSORIES</b>	
20197002	Ramps with shut-off
20197004	Ramps with shut-off - B2B <sup>(1)(2)</sup>
20197005	Ramps without shut-off <sup>(1)(2)</sup>
20197006	Ramps without shut-off - B2B <sup>(1)(2)</sup>
20197634	Gas ramp kit for cascade installation 35-45 kW <sup>(1)</sup>
20197635	Gas ramp kit for cascade installation 55-70 kW <sup>(1)</sup>
20197639	Gas ramp kit for cascade installation 35-45 kW - B2B <sup>(1)</sup>
20197640	Gas ramp kit for cascade installation 55-70 kW - B2B <sup>(1)</sup>
20197007	2" 1/2 manifolds for 2 boiler cascade
20197362	2" 1/2 manifolds for 1 boiler cascade
20197366	Flange 2" 1/2 PN6
20197367	Blind flanges 2"1/2 PN6
20197364	Condensate discharge kit for cascade
20196449	Manifold kit for 2" 1/2 safety devices housing
20197642	2"1/2 hydraulic separator kit
20196494	DN65/DN50 connection kit (HEATGATE DN50) <sup>(3)</sup>
20200611	Heat exchanger SP 35-DN50 21 (21) N <sup>(11)</sup>
20200613	Heat exchanger SP 35-DN50 27 (27) N <sup>(11)</sup>
20200614	Heat exchanger SP 35-DN50 33 (33) N <sup>(11)</sup>
20200615	Heat exchanger SP 35-DN50 41 (41) N <sup>(11)</sup>
20200616	Heat exchanger SP 35-DN50 49 (49) N <sup>(11)</sup>
20200618	Heat exchanger SP 35-DN50 53 (53) N <sup>(11)</sup>
20200619	Heat exchanger SP 35-DN50 61 (61) N <sup>(11)</sup>
<b>SAFETY ACCESSORIES</b>	
20071190	Safety devices kit <sup>(4)</sup>
20197368	Safety valve up to 400 kW (4,5 bar)
20009486	Fuel shut-off valve kit (VIC) - ØG.1" <sup>(7)(8)</sup>
20009482	Fuel shut-off valve kit (VIC) - ØG.1" ½ <sup>(5)(8)</sup>
20009483	Fuel shut-off valve kit (VIC) - ØG.2" <sup>(6)(8)</sup>
<b>MECHANICAL ACCESSORIES</b>	
20197363	Manifolds and ramps cover for stand alone boiler
20120282	Ground fixing kit (SP 35-40 models) <sup>(9)</sup>
<b>FLUE DISCHARGE (*)</b>	
20129769	Vertical flue adapter kit from Ø60/100 to Ø80 (for type B23 installation)
20196315	Ø80/80 - Rainproof vertical adapter
20190475	Compact adjustable splitter kit from Ø60/100 mm to Ø80/80 mm

## POWER EVO-X

CODE	DESCRIPTION
20196312	Adapter from Ø 80/125 mm to Ø80/80 mm
20129765	Fixed split system kit Ø80 mm
20197070	Adapter Ø80 to Ø110
20196319	Ø80/110 - Rainproof vertical adapter
20137506	90° Ø80 mm bend
20137538	Air-intake kit B23
20062338	Cascade terminal Ø160 with condensate drain
20197583	Collector Ø160 for 1 boiler
20197584	Collector Ø200 for 1 boiler
20132391	Adapter Ø160 to Ø200
20197582	Y-fitting Ø160/160
<b>ELECTRICAL ACCESSORIES</b>	
20200265	Cascade and zone remote control <sup>(10)</sup>

(1) To be ordered for each boiler of the cascade system (qty = no. boiler).

(2) Without gas ramp.

(3) To be ordered with the "Ground fixing kit (SP35-40 models) cod. 20120282.

(4) Safety and fuel-shut-off valve are not included.

(5) Recommended up to a maximum output of 131 kW, calculated taking into consideration the gas supply pressure = 20 mbar.

(6) Recommended up to a maximum output of 230 kW, calculated taking into consideration the gas supply pressure = 20 mbar.

(7) Recommended up to a maximum output of 580 kW, calculated taking into consideration the gas supply pressure = 20 mbar.

(8) Intervention temperature 97 °C - Capillary length 5 m.

(9) Allows the plate exchanger to be fixed to the structure contained in the cod.20196494.

(10) Allows the management of: solar thermal and up to 6 direct/mixed independent zones.

(11) Configurations with plate heat exchangers: see the product SP - Inspectable plate heat exchanger, section System Complementary Items..

(\*) Specific codes for the flue discharge/air intake in case of cascade installation.

NOTE: to calculate the maximum admissible output of the fuel shut-off valves, with supply pressures other than 20 mbar, contact the pre-sales service.  
For the flue gas system, refer to the current catalog.

**ACCESSORIES TO COMPLETE THE SYSTEM**

CODE	DESCRIPTION
<b>HYDRAULIC ACCESSORIES</b>	
20190221	1"1/2 MF shut-off cock
4031810	Condensate neutralizer N2 (up to 450 kW)
4031811	Condensate neutralizer HN2 (up to 280 kW) <sup>(1)</sup>
<b>MECHANICAL ACCESSORIES</b>	
20196701	Support frame <sup>(2)</sup>
20196699	Support frame rig <sup>(3)</sup>
<b>ELECTRICAL ACCESSORIES</b>	
20192808	Board BE09 with double multi-function relay
20132795	1st direct/mixed area control <sup>(4)</sup>
20132796	Control of 2nd and 3rd direct/mixed zone <sup>(4)</sup>
1220559	External probe
1220599	Immersion probe <sup>(5)</sup>
20168672	Solar thermal unit interface kit
<b>LPG TRANSFORMATION ACCESSORIES</b>	
20201490	LPG transformation kit (35/45 kW)
20201489	LPG transformation kit (55/70 kW)

(1) Equipped with extraction pumps.

(2) Frame required in case of either cascade installation or stand alone installation with plate heat exchanger.



(3) Necessary in case of back-to-back cascade configuration.

(4) In combination with cod.20207837 in stand alone installation or with cod.20199623 in cascade installation for the management of direct/mixed zones.

(5) Usable as: primary probe, secondary probe, cylinder probe.

## POWER EVO-X

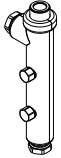
### COMBINATION OF PLATE EXCHANGERS, FOR BOILER OPERATION WITH PRIMARY $\Delta T = 20\text{ }^{\circ}\text{C}$

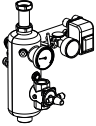
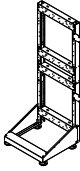
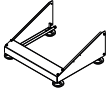
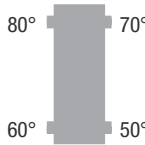
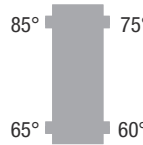
Description	Safety devices		Frame			Heat exchanger				
	Only safety valve		Safety devices		Frame		$\Delta T$ primary/secondary = $10\text{ }^{\circ}\text{C}$		$\Delta T$ primary/secondary = $7,5\text{ }^{\circ}\text{C}$	
										
	Hydraulic separator/plate heat exchanger connection	Safety valve 4,5 bar FF 3/4"x1"	Safety kit manifold	Support frame	Support frame rig	Brazed plate heat exchanger kit for stand alone boiler (20 plates)	Brazed plate heat exchanger kit for stand alone boiler (30 plates)	Brazed plate heat exchanger kit for stand alone boiler (20 plates)	Brazed plate heat exchanger kit for stand alone boiler (30 plates)	
	20195886	20199254	20195883	20196701	20196699	20195888	20197360	20195888	20197360	
POWER EVO-X 50 DEP	■	■	■	■	■ (*)	■		■		
POWER EVO-X 50	■	■	■	■	■ (*)	■		■		
POWER EVO-X 65	■	■	■	■	■ (*)		■		■	
POWER EVO-X 80	■	■	■	■	■ (*)		■		■	

(\*) To be used in cases where the frame kit is not bound to the wall.

### TABLE OF COMBINATION OF BOILER CASCADE COLLECTORS

MODEL	POWER EVO-X 50 DEP	POWER EVO-X 50	POWER EVO-X 65	POWER EVO-X 80
Boiler heat output kW	34,9	45	55	70
No. boilers	TOTAL CASCADE OUTPUT/DIAMETER H2O COLLECTORS			
2	70/ 2"1/2	90/ 2"1/2	110/ 2"1/2	140/ 2"1/2
3	105/ 2"1/2	135/ 2"1/2	165/ 2"1/2	210/ 2"1/2
4	140/ 2"1/2	180/ 2"1/2	220/ 2"1/2	280/ 2"1/2

### TABLE OF COMBINATION OF COLLECTOR CODES IN RELATION TO THE NUMBER OF BOILERS IN CASCADE, IN A FRONT CONFIGURATION

MODEL	POWER EVO-X 50 DEP	POWER EVO-X 50	POWER EVO-X 65	POWER EVO-X 80
Boiler heat output kW	34,9	45	55	70
No. boilers	SELECTION OF COLLECTOR CODES FOR FRONT CONFIGURATION			
2	1x 20197007	1x 20197007	1x 20197007	1x 20197007
3	1x 20197007 1x 20197362	1x 20197007 1x 20197362	1x 20197007 1x 20197362	1x 20197007 1x 20197362
4	2x 20197007	2x 20197007	2x 20197007	2x 20197007

## POWER EVO-X

**TABLE OF COMBINATION OF COLLECTOR CODES IN RELATION TO THE NUMBER OF BOILERS IN CASCADE, IN A BACK TO BACK CONFIGURATION**

MODEL	POWER EVO-X 50 DEP	POWER EVO-X 50	POWER EVO-X 65	POWER EVO-X 80
Boiler heat output kW	34,9	45	55	70
No. boilers	SELECTION OF COLLECTOR CODES FOR BACK TO BACK CONFIGURATION			
2	1x 20197362	1x 20197362	1x 20197362	1x 20197362
3	1x 20197007	1x 20197007	1x 20197007	1x 20197007
4	1x 20197007	1x 20197007	1x 20197007	1x 20197007

**TABLE FOR SELECTING THE FLUE GASES COLLECTORS DIAMETERS IN RELATION TO THE NUMBER OF BOILERS ON EACH COLLECTOR**

MODEL	POWER EVO-X 50 DEP	POWER EVO-X 50	POWER EVO-X 65	POWER EVO-X 80
Boiler heat output kW	34,9	45	55	70
No. boilers	FLUE COLLECTORS DIAMETER			
1a	Ø160	Ø160	Ø160	Ø160
2a	Ø160	Ø160	Ø160	Ø160
3a	Ø160	Ø160	Ø160	Ø160
4a	Ø160	Ø160	Ø160	Ø200

**TABLE OF COMBINATION OF BOILER CASCADE COLLECTORS, IN A FRONT CONFIGURATION**

MODEL	POWER EVO-X 50 DEP	POWER EVO-X 50	POWER EVO-X 65	POWER EVO-X 80
Boiler heat output kW	34,9	45	55	70
No. boilers	SELECTION OF FLUE GASES COLLECTOR CODES FOR FRONT CONFIGURATIONS			
2	2x 20129765 4x 20137506 2x 20137538 2x 20197070 1x 20062338 2x 20197583	2x 20129765 4x 20137506 2x 20137538 2x 20197070 1x 20062338 2x 20197583	2x 20196319 1x 20062338 2x 20197583	2x 20196319 1x 20062338 2x 20197583
3	3x 20129765 6x 20137506 3x 20137538 3x 20197070 1x 20062338 3x 20197583	3x 20129765 6x 20137506 3x 20137538 3x 20197070 1x 20062338 3x 20197583	3x 20196319 1x 20062338 3x 20197583	3x 20196319 1x 20062338 3x 20197583
4	4x 20129765 8x 20137506 4x 20137538 4x 20197070 1x 20062338 4x 20197583	4x 20129765 8x 20137506 4x 20137538 4x 20197070 1x 20062338 4x 20197583	4x 20196319 1x 20062338 4x 20197583	4x 20196319 1x 20062338 1x 20132391 3x 20197583 1x 20197584

## POWER EVO-X

**TABLE OF COMBINATION OF BOILER CASCADE COLLECTORS, IN A BACK TO BACK CONFIGURATION**

MODEL	POWER EVO-X 50 DEP	POWER EVO-X 50	POWER EVO-X 65	POWER EVO-X 80
Boiler heat output kW	34,9	45	55	70
No. boilers	SELECTION OF FLUE GASES COLLECTOR CODES FOR BACK TO BACK CONFIGURATIONS			
2	2x 20129765 4x 20137506 2x 20137538 2x 20197070 2x 20062338 1x 20197582 2x 20197583	2x 20129765 4x 20137506 2x 20137538 2x 20197070 2x 20062338 1x 20197582 2x 20197583	2x 20196319 2x 20062338 1x 20197582 2x 20197583	2x 20196319 2x 20062338 1x 20197582 2x 20197583
3	3x 20129765 6x 20137506 3x 20137538 3x 20197070 2x 20062338 1x 20197582 3x 20197583	3x 20129765 6x 20137506 3x 20137538 3x 20197070 2x 20062338 1x 20197582 3x 20197583	3x 20196319 2x 20062338 1x 20197582 3x 20197583	3x 20196319 2x 20062338 1x 20197582 3x 20197583
4	4x 20129765 8x 20137506 4x 20137538 4x 20197070 2x 20062338 1x 20197582 4x 20197583	4x 20129765 8x 20137506 4x 20137538 4x 20197070 2x 20062338 1x 20197582 4x 20197583	4x 20196319 2x 20062338 1x 20197582 4x 20197583	4x 20196319 2x 20062338 1x 20197582 4x 20197583



Modular condensing wall-hung boilers for indoor application

## POWER MAX



- New condensing high power boiler range that can be installed both as stand-alone or as cascade configuration.
- New condensing heat exchanger in stainless steel.
- Low NOx: Class 6 According to European Directive UNI EN 15502.
- Thanks to embedded 'Managing/Depending' control logic, any boiler can be configured either as the 'Managing' or as a 'Depending' boiler within the cascade (same product code).
- Possibility to cascade up to 1120 kW.
- Built-in thermoregulation with external probe supplied as option.
- Modulating and modular power regulation.
- Automatic burner ignition sequence reversal (at adjustable steps).
- Simultaneous control of two different circuits: DHW tank and high temperature.
- Management of up to 16 zones through an optional kit.
- Automatic summer/winter switch-over.
- 'Anti-legionella' function as standard.
- Suitable for remote control management (0-10V input or Modbus) via optional kit.
- Availability of a wide range of accessories for complete configurations.
- Can be converted to LPG through LPG kit supplied as standard.

INTERAXES AND HYDRAULIC FITTINGS POSITIONING



### B3 TYPE PRE-MIXED CONDENSING BOILER

CODE	LANGUAGE	MODEL	DIMENSIONS H x W x D (mm)	FLUE GAS (Ø mm)	OUTPUT NCV <sup>(1)</sup> (GCV) <sup>(2)</sup> min-max (kW)	CLASS
						(D→A+++)*
20128431	IT / EN	POWER MAX 65	1000 x 600 x 435	80	14.0 - 57.0 (63.0)	A
20151859	FR					
20151867	PT					
20151885	PL / RO					
20151893	SK / CZ / GR / SI / CR					
20128432	IT / EN	POWER MAX 80 P	1000 x 600 x 435	80	14.0 - 68.0 (76.0)	A
20151860	FR					
20151870	PT					
20151886	PL / RO					
20151894	SK / CZ / GR / SI / CR					
20128433	IT / EN	POWER MAX 100	1000 x 600 x 435	110	19.4 - 90.0 (100.0)	-
20151861	FR					
20151872	PT					
20151887	PL / RO					
20151895	SK / CZ / GR / SI / CR					

## POWER MAX - THE RANGE

CODE	LANGUAGE	MODEL	DIMENSIONS H x W x D (mm)	FLUE GAS (Ø mm)	OUTPUT NCV <sup>(1)</sup> (GCV) <sup>(2)</sup> min-max (kW)	CLASS
						(D→A+++)*
20128434	IT / EN	POWER MAX 110	1000 x 600 x 435	110	19.4 - 97.0 (108.0)	-
20151862	FR					
20151874	PT					
20151888	PL / RO					
20151896	SK / CZ / GR / SI / CR					
20128435	IT / EN	POWER MAX 130	1170 x 600 x 435	110	22.4 - 112.0 (124.0)	-
20151863	FR					
20151880	PT					
20151889	PL / RO					
20151897	SK / CZ / GR / SI / CR					
20128436	IT / EN	POWER MAX 150	1170 x 600 x 435	110	26.2 - 131.0 (146.0)	-
20151864	FR					
20151881	PT					
20151890	PL / RO					
20151898	SK / CZ / GR / SI / CR					

(\*) HEATING: the energy class of the products ranges from D up to A+++

(1) NCV = Net Calorific Value or Lower Calorific Value (LCV)

(2) GCV = Gross Calorific Value or Higher Calorific Value (HCV)

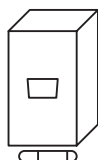

6  
STAND-ALONE  
configurations

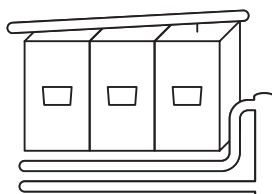

52  
FRONT CASCADE  
configurations

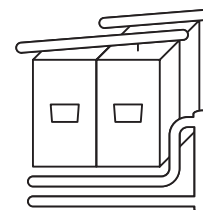

52  
BACK-TO-BACK CASCADE  
configurations

Power MAX range consists of **6 MODELS**, that can be installed either as stand-alone or in cascade configuration (front and back to back), totalling 110 configurations in all.

**ATTENTION:** every model is available under different codes, according to the documentation language/s of the instruction manual supplied with the product.

Please select the right code of your model according to the documentation language you need:

- IT / EN (Italian / English)
- FR (French)
- PT (Portuguese)
- PL / RO (Polish / Romanian)
- SK / CZ / GR / SI / CR (Slovak / Czech / Greek / Slovenian / Croatian)

Modular condensing wall-hung boilers for indoor application

## POWER MAX - STAND ALONE APPLICATION

### A - CONFIGURATION GUIDE FOR STAND ALONE APPLICATION AND ACCESSORIES SELECTION

For the selection of the components of the stand alone configuration, please follow the flow chart below and refer to the relevant tables in the following pages..



#### 1. STAND ALONE BOILER CONFIGURATION

#### 2. ACCESSORIES TO COMPLETE THE SYSTEM

#### 3. OPTIONAL ACCESSORIES

3.1 Shunt pumps

3.2 Additional safety devices

3.3 Hydraulic separator or plate heat exchanger\*

3.4 Secondary circuit management

3.5 Sealed chamber conversion kit

3.6 Flue system

3.7 Remote control

3.8 Treatment systems for condensate neutralization

(\*): Configurations with plate heat exchangers: see the product SP - Inspectable plate heat exchanger, section System Complementary Items.

#### 1. STAND ALONE BOILER CONFIGURATION

Model	POWER MAX 65 P	POWER MAX 80 P	POWER MAX 100	POWER MAX 110	POWER MAX 130 (115 Hi)	POWER MAX 150
Heat Input Boiler kW	57	68	90	97	112	131

#### 2. ACCESSORIES TO COMPLETE THE SYSTEM

CODE	DESCRIPTION
20132778	External probe
20133102	Condensate drain trap kit for stand alone boiler (1)

(1) Mandatory on all models

### 3. OPTIONAL ACCESSORIES

#### 3.1 SHUNT PUMPS (ONLY FOR 100÷150 KW)

CODE	DESCRIPTION
20125034	Injection pump kit POWER MAX 100 - 110 - 130 (115 Hi) <sup>(1) (2)</sup>
20125035	Injection pump kit POWER MAX 130 (115 Hi) <sup>(3)</sup>
20125040	High head injection pump kit POWER MAX 150 <sup>(1) (4)</sup>

(1) For POWER MAX 65 P - 80 P models the pump is already present in the boiler

(2) The pump, which can be housed in the boiler, offers a high residual head on POWER MAX 100 and 110, and with these boilers it is also suitable in combination with the plate exchanger; if the pump is used with POWER MAX 130 (115 Hi) it allows the combination with the hydraulic separator but not with the plate exchanger

(3) If combined with POWER MAX 150, this circulation pump can be fitted inside the boiler and offers a very low residual head (10 mbar); it must be used ONLY in combination with the horizontal hydraulic separator code: 20131897

(4) This circulation pump cannot be fitted inside the boiler, it must be installed under the boiler

#### 3.2 ADDITIONAL SAFETY DEVICES

CODE	DESCRIPTION
20142219	SA installation kit for stand-alone boiler <sup>(1) (2)</sup>
20131898	Manifold kit with safety devices for stand alone boiler <sup>(3)</sup>
20189780	Manifold kit with safety devices for stand alone boiler <sup>(4) (5)</sup>
20143981	Safety valve 5.4 bar ØG.¾" FF
20131899	Kit with connection pipe to hydraulic separator for stand alone boiler
20190221	Shut-off cock

(1) This kit is necessary for the stand-alone installation. It contains: connection pipe kit (1x code 20131899), hydraulic separator kit for stand alone boiler (1x code 20131897), condensate drain syphone (1x code 20133102), safety valve 5.4 bar (1x code 20143981) and 2 ball valves.

(2) Condensate drain syphone (code 20133102) is not included in the boilers.

(3) Includes all the safety devices, including safety valve and VIC mandatory for the Italian market.

(4) Includes pressure gauge, thermometer and 3 bar safety valve (¾ "FF). Coupled with the under boiler cover kits (20145587 or 20133224) it allows the display of temperature and pressure values.

(5) If an operating pressure > 3 bar is required, it can be combined with the safety valve code 20143981.

#### 3.3 HYDRAULIC SEPARATOR OR PLATE HEAT EXCHANGER

CODE	DESCRIPTION
20131897	Horizontal hydraulic separator kit for stand alone boiler
20133224	Cover for safety kit/hydraulic separator unit for stand alone boiler
20125037	2/3 way valve kit <sup>(1)</sup>
20131663	Frame kit for front cascades <sup>(2)</sup>
20131664	Frame conversion kit for B2B cascades <sup>(2)</sup>
20132368	Brazed plate heat exchanger kit for stand alone boiler (20 plates) <sup>(3)</sup>
20132369	Brazed plate heat exchanger kit for stand alone boiler (30 plates) <sup>(3)</sup>
20132370	Brazed plate heat exchanger kit for stand alone boiler (40 plates) <sup>(3)</sup>
20132371	Brazed plate heat exchanger kit for stand alone boiler (50 plates) <sup>(3)</sup>
20132372	Brazed plate heat exchanger kit for stand alone boiler (60 plates) <sup>(3)</sup>
20136823	Delivery/return line fittings kit for direct installation <sup>(4)</sup>
20145587	Cover for plate heat exchanger

(1) The two-way valve kit combined with the plate exchanger kit codes for stand alone boiler (except code 20132368) allows the direct production of DHW.











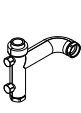

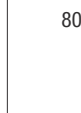

(2) The frame is necessary in case of installation with plate exchanger; if the frame kit is not fixed to the wall, it is necessary to buy also the kit for the use of the front and back frame code 20131664.

(3) It includes the plate exchanger and the connection trains; the plate exchanger always requires the frame kit code 20131663 and a pump with high residual head, therefore on boilers Power Max 130 and Power Max 150 it is necessary to use the high head circulating pump.

(4) Kit compatible with all POWER MAX models in case of presence of kit and without the need of hydraulic separator.

## POWER MAX - SINGLE APPLICATION - SELECTION OF COMPONENTS

### PUMP AND PLATE HEAT EXCHANGER COMBINATIONS FOR BOILER OPERATION WITH PRIMARY $\Delta T = 20^{\circ}\text{C}$

Commercial name	Safety devices		Frame		Pumps			Plate heat exchangers								
								$\Delta T$ Primary/secondary = $10^{\circ}\text{C}$				$\Delta T$ Primary/secondary = $7,5^{\circ}\text{C}$				
																
	Kit with connection pipe to hydraulic separator for stand alone boiler	Safety valve 5,4 bar $\varnothing 6,3/4"$ FF	Manifold kit with safety devices for stand alone boiler	Frame kit for front cascades	Frame conversion kit for B2B cascades	Injection pump kit POWER MAX 100 - 110 - 130 (115 Hi)	Injection pump kit POWER MAX 130	High head injection pump kit POWER MAX 150	Brazed plate heat exchanger kit for stand alone boiler (20 plates)	Brazed plate heat exchanger kit for stand alone boiler (30 plates)	Brazed plate heat exchanger kit for stand alone boiler (40 plates)	Brazed plate heat exchanger kit for stand alone boiler (60 plates)	Brazed plate heat exchanger kit for stand alone boiler (30 plates)	Brazed plate heat exchanger kit for stand alone boiler (40 plates)	Brazed plate heat exchanger kit for stand alone boiler (50 plates)	Brazed plate heat exchanger kit for stand alone boiler (60 plates)
	20131899	20143981	20189780	20131663	20131664	20125034	20125035	20125040	20132368	20132369	20132370	20132372	20132369	20132370	20132371	20132372
POWER MAX 65 P	■	■	■	■	■ (*)	■			■				■			
POWER MAX 80 P	■	■	■	■	■ (*)	■			■				■			
POWER MAX 100	■	■	■	■	■ (*)	■				■				■		
POWER MAX 110	■	■	■	■	■ (*)	■				■				■		
POWER MAX 130 (115 Hi)	■	■	■	■	■ (*)		■				■				■	
POWER MAX 150	■	■	■	■	■ (*)			■				■				■

(\*) To be used when the frame kit is not held on the wall.

### 3.4 SECONDARY CIRCUIT MANAGEMENT

CODE	DESCRIPTION
1220599	Secondary circuit/heater probe <sup>(1)</sup>
20220356	Electronic kit for management of single direct or additional mixed zone (max 16) <sup>(2)</sup>

Note: for adjusting the ambient temperature use thermostats and chronothermostats.

(1) Probe necessary for the boiler or to control the secondary circuit, with temperature alignment with the one set for the primary circuit.

(2) The kit includes the necessary probe for the mixed zone.

### 3.5 SEALED CHAMBER CONVERSION KIT

CODE	DESCRIPTION
20131665	Type C conversion kit for POWER MAX 65 P - 80 P
20131668	Type C conversion kit for POWER MAX 100 - 110 - 130 (115 Hi) - 150

## POWER MAX - SINGLE APPLICATION - SELECTION OF COMPONENTS

### 3.6 FLUE SYSTEM

CODE	DESCRIPTION
20131270	Spacer kit for wall mounting <sup>(1)</sup>

(1) Kit necessary for wall rear concentric exhaust.

Note: for each type, check the maximum equivalent lengths by referring to the technical data sheet and/or by contacting the pre-sales service.  
For flue gas exhaust system refer to page 263.

### 3.7 REMOTE CONTROL

CODE	DESCRIPTION
20213521	POWER MAX remote control kit <sup>(1)</sup>

(1) Necessary for hourly programming of the heater and for programming of zones (also those managed by the additional zone kits)

### 3.8 TREATMENT SYSTEMS FOR CONDENSATE NEUTRALIZATION

CODE	DESCRIPTION
4031811	Neutralization kit HN2 up to 270 kW <sup>(1)</sup> <sup>(2)</sup>
4031810	Neutralization kit N2 up to 450 kW <sup>(1)</sup>

(1) Delivery time of the material if not available in stock: up to 30 working days from order validation date.

(2) With condensate booster pump

Modular condensing wall-hung boilers for indoor application

## POWER MAX - CASCADE APPLICATION - SELECTION OF COMPONENTS

### B - GUIDE TO SYSTEM CONFIGURATION WITH CASCADE BOILERS AND SELECTION OF ACCESSORIES

For selection of components for cascade configuration, follow the flowchart going to the corresponding tables



#### 1. BOILERS CASCADE CONFIGURATION

#### 2. SELECTION OF THE LAYOUT FRONT OR BACK-TO-BACK

#### 3. ACCESSORIES TO COMPLETE THE SYSTEM

#### 4. ACCESSORIES

4.1 Support frame

4.2 Shunt pumps

4.3 Connection pipes

4.4 Water collectors (delivery/return) -gas-condensate

4.5 Additional safety devices

4.6 Hydraulic separator or plate heat exchanger\*

4.7 Secondary circuit management

4.8 Sealed chamber conversion kit

4.9 Flue gas exhaust systems

4.10 Remote control

4.11 Treatment systems for condensate neutralization

(\*): Configurations with plate heat exchangers: see the product SP - Inspectable plate heat exchanger, section System Complementary Items.

Modular condensing wall-hung boilers for indoor application

## POWER MAX - CASCADE APPLICATION - CONFIGURATIONS

### 1. BOILER CASCADE CONFIGURATION

Output obtainable with cascade system installation.

Model	POWER MAX 65 P	POWER MAX 80 P	POWER MAX 100	POWER MAX 110	POWER MAX 130 (115 Hi)	POWER MAX 150
Heat Input Boiler kW	57	68	90	97	112	131
No. of boilers	Total cascade heat input (Hi)					
2	114	136	180	194	224	262
3	171	204	270	291	336	393
4	228	272	360	388	448	524
5	285	340	450	485	560	655
6	342	408	540	582	672	786
7	399	476	630	679	784	917
8	456	544	720	776	896	1048
9	513	612	810	873	1008	ND
10	570	680	900	970	1120	ND

#### COLOUR KEY

	Solution with the lowest number of boilers
	Solution that provides, for the same output, a greater number of boilers and therefore a greater modulation ratio
	Solution that provides the maximum modulation ratio for the same output
ND	Solution not available

### 2. SELECTION OF THE LAYOUT FRONT OR BACK-TO-BACK

#### 2.1 FRONT

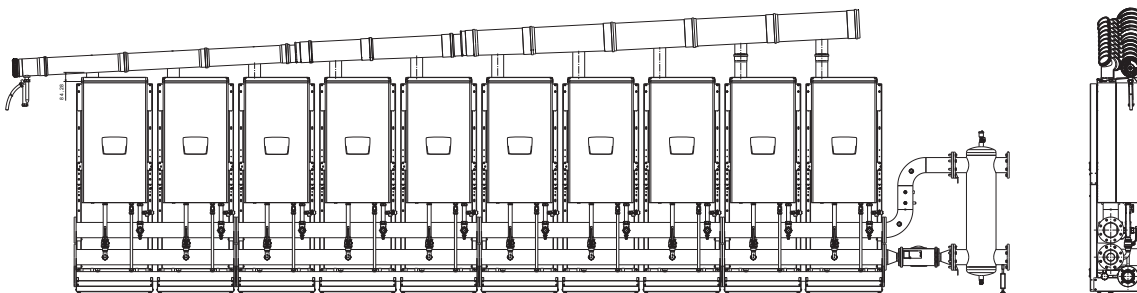

#### 2.2 BACK-TO-BACK (A)

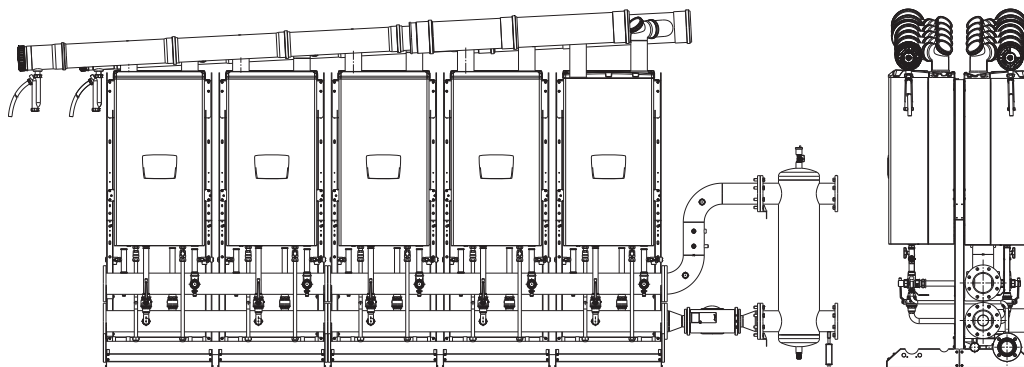

(A) To connect to a single chimney, use Y connections, choosing them from section "Cascade application - Flue"

## POWER MAX - CASCADE APPLICATION - SELECTION OF COMPONENTS

### 3. ACCESSORIES TO COMPLETE THE SYSTEM

CODE	DESCRIPTION
20132778	External probe <sup>(1)</sup>
20175716	Primary circuit probe <sup>(1)</sup>
20131267	Condensate drain trap kit for cascade boiler <sup>(2)</sup>
20151288	Set of manuals for the POWER MAX CASCADE (FR)
20151290	Set of manuals for the POWER MAX CASCADE (PT)
20151289	Set of manuals for the POWER MAX CASCADE (PL - RO)
20151952	Set of manuals for the POWER MAX CASCADE (SK - CZ - GR - SI - CR)

(1) No.1 pc. for each cascade system, to be connected to the main boiler, i.e. the one that controls the cascade system

(2) To be ordered for each boiler of the cascade system (qty = no. of boilers)

Select the correct code according to the language of the documentation required:

- FR (French)
- PT (Portuguese)
- PL / RO (Polish / Romanian)
- SK / CZ / GR / SI / CR (Slovak / Czech / Greek / Slovenian / Croatian)

### 4. ACCESSORIES

#### 4.1 SUPPORT FRAME

CODE	DESCRIPTION
20131663	Frame kit for FRONT cascades
20131664	Frame conversion kit for BACK-TO-BACK cascades

No. of boilers	FRONT		BACK-TO-BACK	
	Q.ty of frames cod. 20131663	Q.ty of frames cod. 20131663	Q.ty of conversion kits cod. 20131664	
2	2	1	1	
3	3	2	2	
4	4	2	2	
5	5	3	3	
6	6	3	3	
7	7	4	4	
8	8	4	4	
9	9	5	5	
10	10	5	5	

## POWER MAX - CASCADE APPLICATION - CONFIGURATIONS

### 4.2 SHUNT PUMPS (ONLY FOR 100÷150 KW)

CODE	DESCRIPTION
20125034	Injection pump kit POWER MAX 100 - 110 - 130 (115 Hi) <sup>(1)</sup>
20125035	Injection pump kit POWER MAX 130
20125040	High head injection pump kit POWER MAX 150 <sup>(2)</sup>

(1) To be ordered for each boiler of the cascade system (qty = no. of boilers); pump to be installed inside the boiler

(2) To be ordered for each boiler of the cascade system (qty = no. of boilers); pump to be installed outside the boiler

### 4.3 CONNECTION PIPES

FRONT CONFIGURATION	
CODE	DESCRIPTION
20130658	Trains without shut-off for POWER MAX 65 P - 80 P - 100 - 110 - 130 (115 Hi) - 150 <sup>(1)</sup>
20131124	Trains with shut-off for POWER MAX 65 P - 80 P - 100 - 110 - 130 (115 Hi) - 150 <sup>(1)</sup>
20131121	Trains without shut-off for POWER MAX 150 (external pump) <sup>(2)</sup>
20131125	Trains with shut-off for POWER MAX 150 (external pump) <sup>(2)</sup>

(1) To be ordered for each boiler of the cascade system (qty = no. of boilers) with pump installed inside the boiler

(2) To be ordered for each boiler of the cascade system (qty = no. of boilers) with pump installed outside the boiler

BACK-TO-BACK CONFIGURATION	
CODE	DESCRIPTION
20130658	Trains without shut-off for POWER MAX 65 P - 80 P - 100 - 110 - 130 (115 Hi) - 150 <sup>(3)</sup>
20131124	Trains with shut-off for POWER MAX 65 P - 80 P - 100 - 110 - 130 (115 Hi) - 150 <sup>(3)</sup>
20131121	Trains without shut-off for POWER MAX 150 (external pump) <sup>(4)</sup>
20131125	Trains with shut-off for POWER MAX 150 (external pump) <sup>(4)</sup>
20131787	Trains without shut-off for POWER MAX 65 P - 80 P - 100 - 110 - 130 (115 Hi) - 150 BACK-TO-BACK <sup>(5)</sup>
20131791	Trains with shut-off for POWER MAX 65 P - 80 P - 100 - 110 - 130 (115 Hi) - 150 BACK-TO-BACK <sup>(5)</sup>
20131788	Trains without shut-off for POWER MAX 150 (external pump) BACK-TO-BACK <sup>(6)</sup>
20131792	Trains with shut-off for POWER MAX 150 (external pump) BACK-TO-BACK <sup>(6)</sup>

(3) To be ordered for each collector side boiler with pump installed inside the boiler

(4) To be ordered for each collector side boiler with pump installed outside the boiler

(5) To be ordered for each boiler opposite to the collectors with pump installed inside the boiler

(6) To be ordered for each boiler opposite to the collectors with pump installed outside the boiler

## POWER MAX - CASCADE APPLICATION - SELECTION OF COMPONENTS

### 4.4 WATER COLLECTORS (DELIVERY/RETURN) - GAS-CONDENSATE

CODE	DESCRIPTION
20133220	Kit of 3" flanged DN80 + threaded GAS 2" hydraulic collectors - for 1 frame <sup>(1)</sup>
20130220	Kit of 3" flanged DN80 + threaded GAS 2" hydraulic collectors - for 2 frames (up to 485 kW) <sup>(2)</sup>
20130221	Kit of 3" flanged DN80 + threaded GAS 2" hydraulic collectors - for 3 frames (up to 485 kW) <sup>(2)</sup>
20130222	Kit of 5" flanged DN125 + flanged 3" flanged DN80 3" hydraulic collectors - for 2 frames (above 485 kW) <sup>(3)</sup>
20130223	Kit of 5" flanged DN125 + flanged 3" flanged DN80 3" hydraulic collectors - for 3 frames (above 485 kW) <sup>(3)</sup>
20132377	Collector and train cover kit - for single POWER MAX in cascade
20070903	Closing 3" cap kit <sup>(4)</sup>
20082190	Through 3" flange kit
20070907	Closing 5" cap kit <sup>(4)</sup>
20082191	Through 5" flange kit

(1) To be used only for BACK-TO-BACK configuration with no.2 boilers; it includes DN80 3" flanged delivery and return collectors, 2" threaded gas collector, condensate drain collector

(2) To be used with maximum output up to 485 kW. It includes DN80 3" flanged delivery and return collectors, 2" threaded gas collector, condensate drain collector

(3) To be used with maximum output over 485 kW. It includes DN 125 5" flanged delivery and return collectors, DN80 3" flanged gas collector, condensate drain collector

(4) They allow the closure, on one side, of the gas collector and the two hydraulic collectors

### COMBINATION TABLE FOR CASCADE BOILER HEAT INPUT COLLECTORS

Model	POWER MAX 65 P	POWER MAX 80 P	POWER MAX 100	POWER MAX 110	POWER MAX 130 (115 Hi)	POWER MAX 150
Heat Input Boiler kW	57	68	90	97	112	131
No. of boilers	TOTAL CASCADE HEAT INPUT (kW) / DIAMETER OF HYDRAULIC COLLECTORS (inches)					
2	114/3"	136/3"	180/3"	194/3"	224/3"	262/3"
3	171/3"	204/3"	270/3"	291/3"	336/3"	393/3"
4	228/3"	272/3"	360/3"	388/3"	448/3"	524/5"
5	285/3"	340/3"	450/3"	485/3"	560/5"	655/5"
6	342/3"	408/3"	540/5"	582/5"	672/5"	786/5"
7	399/3"	476/3"	630/5"	679/5"	784/5"	917/5"
8	456/3"	544/5"	720/5"	776/5"	896/5"	1048/5"
9	513/5"	612/5"	810/5"	873/5"	1008/5"	-
10	570/5"	680/5"	970/5"	970/5"	1120/5"	-

## POWER MAX - CASCADE APPLICATION - SELECTION OF COMPONENTS

### COLLECTOR CODE SELECTION TABLE ACCORDING TO THE NUMBER OF BOILERS IN CASCADE, FRONT CONFIGURATION

Model	POWER MAX 65 P	POWER MAX 80 P	POWER MAX 100	POWER MAX 110	POWER MAX 130 (115 Hi)	POWER MAX 150
Heat Input Boiler kW	57	68	90	97	112	131
No. of boilers	Hydraulic collector code selection for FRONT configurations					
2	1 x 20130220	1 x 20130220	1 x 20130220	1 x 20130220	1 x 20130220	1 x 20130220
3	1 x 20130221	1 x 20130221	1 x 20130221	1 x 20130221	1 x 20130221	1 x 20130221
4	2 x 20130220	2 x 20130220	2 x 20130220	2 x 20130220	2 x 20130220	2 x 20130222
5	1 x 20130220 1 x 20130221	1 x 20130220 1 x 20130221	1 x 20130220 1 x 20130221	1 x 20130220 1 x 20130221	1 x 20130222 1 x 20130223	1 x 20130222 1 x 20130223
6	2 x 20130221	2 x 20130221	2 x 20130223	2 x 20130223	2 x 20130223	2 x 20130223
7	2 x 20130220 1 x 20130221	2 x 20130220 1 x 20130221	2 x 20130222 1 x 20130223	2 x 20130222 1 x 20130223	2 x 20130222 1 x 20130223	2 x 20130222 1 x 20130223
8	1 x 20130220 2 x 20130221	1 x 20130222 2 x 20130223	1 x 20130222 2 x 20130223	1 x 20130222 2 x 20130223	1 x 20130222 2 x 20130223	1 x 20130222 2 x 20130223
9	3 x 20130223	3 x 20130223	3 x 20130223	3 x 20130223	3 x 20130223	-
10	2 x 20130222 2 x 20130223	2 x 20130222 2 x 20130223	2 x 20130222 2 x 20130223	2 x 20130222 2 x 20130223	2 x 20130222 2 x 20130223	-

### COLLECTOR CODE SELECTION TABLE ACCORDING TO THE NUMBER OF BOILERS IN CASCADE, BACK-TO-BACK CONFIGURATION

Model	POWER MAX 65 P	POWER MAX 80 P	POWER MAX 100	POWER MAX 110	POWER MAX 130 (115 Hi)	POWER MAX 150
Heat Input Boiler kW	57	68	90	97	112	131
No. of boilers	Hydraulic collector code selection for BACK-TO-BACK configurations					
2	1 x 20133220	1 x 20133220	1 x 20133220	1 x 20133220	1 x 20133220	1 x 20133220
3	1 x 20130220	1 x 20130220	1 x 20130220	1 x 20130220	1 x 20130220	1 x 20130220
4	1 x 20130220	1 x 20130220	1 x 20130220	1 x 20130220	1 x 20130220	1 x 20130222
5	1 x 20130221	1 x 20130221	1 x 20130221	1 x 20130221	1 x 20130223	1 x 20130223
6	1 x 20130221	1 x 20130221	1 x 20130223	1 x 20130223	1 x 20130223	1 x 20130223
7	2 x 20130220	2 x 20130220	2 x 20130222	2 x 20130222	2 x 20130222	2 x 20130222
8	2 x 20130220	2 x 20130222	2 x 20130222	2 x 20130222	2 x 20130222	2 x 20130222
9	1 x 20130222 1 x 20130223	1 x 20130222 1 x 20130223	1 x 20130222 1 x 20130223	1 x 20130222 1 x 20130223	1 x 20130222 1 x 20130223	-
10	1 x 20130222 1 x 20130223	1 x 20130222 1 x 20130223	1 x 20130222 1 x 20130223	1 x 20130222 1 x 20130223	1 x 20130222 1 x 20130223	-

## POWER MAX - CASCADE APPLICATION - SELECTION OF COMPONENTS

### 4.5 ADDITIONAL SAFETY DEVICES

CODE	DESCRIPTION
20070910	Manifold kit for 3" safety devices housing <sup>(1)</sup>
20070912	Manifold kit for 5" safety devices housing <sup>(1)</sup>
20071190	Safety devices kit
20023104	Safety valve up to 460 kW (5,4 bar ØG.¾" F)
20023106	Safety valve up to 580 kW (5,4 bar ØG.1" F)
20009486	Fuel shut-off valve - Ø G.1" - TS=97°C - Capillary L=5 m <sup>(2)</sup>
20009482	Fuel shut-off valve - Ø G.1" 1/2 - TS=97°C - Capillary L=5 m <sup>(3)</sup>
20009483	Fuel shut-off valve - Ø G.2" - TS=97°C - Capillary L=5 m <sup>(4)</sup>
20061640	Fuel shut-off valve - Ø G.3" - TS=97°C - Capillary L=5 m <sup>(5)</sup>
20161191	Flanged 3" DN80 PN6/flanged ØG.3" DN80 PN16 adapter kit for VIC valve <sup>(6)</sup>

(1) Intended for use in cascade systems without primary circuit circulating pump

(2) Recommended up to maximum heat input of 131 kW, calculated considering gas supply pressure = 20 mbar

(3) Recommended up to maximum heat input of 230 kW, calculated considering gas supply pressure = 20 mbar

(4) Recommended up to maximum heat input of 580 kW, calculated considering gas supply pressure = 20 mbar

(5) Recommended up to maximum heat input of 1150 kW, calculated considering gas supply pressure = 20 mbar

(6) To be installed in combination with Fuel shut-off valve - Ø G.3" - TS=97°C - Capillary L=5 m code 20061640

Note: Calculation of the maximum permissible output of VICs with supply pressure of 20 mbar

### SAFETY VALVE SELECTION TABLE

Total cascade heat input (kW)	0 ÷ 460	461 ÷ 580	581 ÷ 920	921 ÷ 1160
(No.) Diameter of safety valve	1 x 3/4"	1 x 1"	2 x 3/4"	2 x 1"
	1x code 20023104	1x code 20023106	2x code 20023104	2x code 20023106

### 4.6. HYDRAULIC SEPARATOR OR PLATE HEAT EXCHANGER

CODE	DESCRIPTION
20009467	Hydraulic 5" separator kit - up to 485 kW (3" connections) <sup>(1)</sup>
20069073	Hydraulic 10" separator kit - up to 580 kW (5" connections) <sup>(2)</sup>
20069074	Hydraulic 10" separator kit - up to 1120 kW (5" connections) <sup>(3)</sup>
20132373	Connection kit for plate exchanger (DN80 on 3" collector side /DN50 on plate exchanger side) <sup>(4)</sup>
20203733	Connection kit for plate exchanger (DN125 on 5" collector side /DN65 on plate exchanger side) <sup>(4)</sup>
20132376	Connection kit for plate exchanger (DN125 on 5" collector side /DN100 on plate exchanger side) <sup>(5)</sup>
20120282	Ground fixing kit (SP 35-40 models)
20120284	Ground fixing kit (SP 60 models)

(1) To be used with maximum output up to 485 kW in combination with 3" collectors

(2) To be used with maximum output above 485 and up to 580 kW in combination with 5" collectors

(3) To be used with maximum output above 580 kW and up to 1120 kW in combination with 5" collectors

(4) To be mandatory ordered with "Ground fixing kit SP 35-40" code 20120282

(5) To be mandatory ordered with "Ground fixing kit SP 60" code 20120284

## POWER MAX - CASCADE APPLICATION - SELECTION OF COMPONENTS

### POWER MAX AND PLATE EXCHANGERS COMBINATION

HIGH-TEMPERATURE COMBINATIONS			$\Delta T$ primary/secondary = 10°C			$\Delta T$ primary/secondary = 7,5°C		
NO. OF BOILERS	MODEL	USEFUL OUTPUT POWER kW	HEAT EXCHANGER	DN	CODE	HEAT EXCHANGER	DN	CODE
2	POWER MAX 2X 65 P	114	SP 35-DN50 21 (21) N	Rp 2" (G-M)*	20200611	SP 35-DN50 33 (33) N	Rp 2" (G-M)*	20200614
	POWER MAX 2X 80 P	136	SP 35-DN50 21 (21) N	Rp 2" (G-M)*	20200611	SP 35-DN50 33 (33) N	Rp 2" (G-M)*	20200614
	POWER MAX 2X 100	180	SP 35-DN50 27 (27) N	Rp 2" (G-M)*	20200613	SP 35-DN50 49 (49) N	Rp 2" (G-M)*	20200616
	POWER MAX 2X 110	194	SP 35-DN50 33 (33) N	Rp 2" (G-M)*	20200614	SP 35-DN50 49 (49) N	Rp 2" (G-M)*	20200616
	POWER MAX 2X 130 (115 HI)	224	SP 35-DN50 33 (33) N	Rp 2" (G-M)*	20200614	SP 35-DN50 53 (53) N	Rp 2" (G-M)*	20200618
	POWER MAX 2X 150	262	SP 35-DN50 41 (41) N	Rp 2" (G-M)*	20200615	SP 35-DN50 61 (61) N	Rp 2" (G-M)*	20200619
3	POWER MAX 3X 65 P	171	SP 35-DN50 27 (27) N	Rp 2" (G-M)*	20200613	SP 35-DN50 41 (41) N	Rp 2" (G-M)*	20200615
	POWER MAX 3X 80 P	204	SP 35-DN50 33 (33) N	Rp 2" (G-M)*	20200614	SP 35-DN50 49 (49) N	Rp 2" (G-M)*	20200616
	POWER MAX 3X 100	270	SP 35-DN50 41 (41) N	Rp 2" (G-M)*	20200615	SP 35-DN50 61 (61) N	Rp 2" (G-M)*	20200619
	POWER MAX 3X 110	291	SP 35-DN50 41 (41) N	Rp 2" (G-M)*	20200615	SP 35-DN50 71 (71) N	Rp 2" (G-M)*	20200620
	POWER MAX 3X 130 (115 HI)	336	SP 35-DN50 49 (49) N	Rp 2" (G-M)*	20200616	SP 35-DN50 81 (81) N	Rp 2" (G-M)*	20200621
	POWER MAX 3X 150	393	SP 35-DN50 61 (61) N	Rp 2" (G-M)*	20200619	SP 35-DN50 89 (89) N	Rp 2" (G-M)*	20200622
4	POWER MAX 4X 65 P	228	SP 35-DN50 33 (33) N	Rp 2" (G-M)*	20200614	SP 35-DN50 53 (53) N	Rp 2" (G-M)*	20200618
	POWER MAX 4X 80 P	272	SP 35-DN50 41 (41) N	Rp 2" (G-M)*	20200615	SP 35-DN50 61 (61) N	Rp 2" (G-M)*	20200619
	POWER MAX 4X 100	360	SP 35-DN50 49 (49) N	Rp 2" (G-M)*	20200616	SP 35-DN50 81 (81) N	Rp 2" (G-M)*	20200621
	POWER MAX 4X 110	388	SP 35-DN50 53 (53) N	Rp 2" (G-M)*	20200618	SP 35-DN50 89 (89) N	Rp 2" (G-M)*	20200622
	POWER MAX 4X 130 (115 HI)	448	SP 35-DN50 61 (61) N	Rp 2" (G-M)*	20200619	SP 35-DN50 101 (101) N	Rp 2" (G-M)*	20200623
	POWER MAX 4X 150	524	SP 50-DN65 35 (14) N	Rp 2" 1/2 (G-M)*	20200635	SP 50-DN65 55 (22) N	Rp 2" 1/2 (G-M)*	20200642
5	POWER MAX 5X 65 P	285	SP 35-DN50 41 (41) N	Rp 2" (G-M)*	20200615	SP 35-DN50 71 (71) N	Rp 2" (G-M)*	20200620
	POWER MAX 5X 80 P	340	SP 35-DN50 49 (49) N	Rp 2" (G-M)*	20200616	SP 35-DN50 81 (81) N	Rp 2" (G-M)*	20200621
	POWER MAX 5X 100	450	SP 35-DN50 61 (61) N	Rp 2" (G-M)*	20200619	SP 35-DN50 101 (101) N	Rp 2" (G-M)*	20200623
	POWER MAX 5X 110	485	SP 35-DN50 71 (71) N	Rp 2" (G-M)*	20200620	SP 35-DN50 101 (101) N	Rp 2" (G-M)*	20200623
	POWER MAX 5X 130 (115 HI)	560	SP 50-DN65 41 (17) N	Rp 2" (G-M)*	20200637	SP 50-DN65 55 (22) N	Rp 2" 1/2 (G-M)*	20200642
	POWER MAX 5X 150	655	SP 50-DN65 45 (18) N	Rp 2" (G-M)*	20200638	SP 50-DN65 65 (26) N	Rp 2" 1/2 (G-M)*	20200645

## POWER MAX - CASCADE APPLICATION - SELECTION OF COMPONENTS

HIGH-TEMPERATURE COMBINATIONS			$\Delta T$ primary/secondary = 10°C			$\Delta T$ primary/secondary = 7,5°C		
NO. OF BOILERS	MODEL	USEFUL OUTPUT POWER kW	HEAT EXCHANGER	DN	CODE	HEAT EXCHANGER	DN	CODE
6	POWER MAX 6X 65 P	342	SP 35-DN50 49 (49) N	Rp 2" (G-M)*	20200616	SP 35-DN50 81 (81) N	Rp 2" (G-M)*	20200621
	POWER MAX 6X 80 P	408	SP 35-DN50 61 (61) N	Rp 2" (G-M)*	20200619	SP 35-DN50 89 (89) N	Rp 2" (G-M)*	20200622
	POWER MAX 6X 100	540	SP 50-DN65 35 (14) N	Rp 2" 1/2 (G-M)*	20200635	SP 50-DN65 55 (22) N	Rp 2" 1/2 (G-M)*	20200642
	POWER MAX 6X 110	582	SP 50-DN65 41 (17) N	Rp 2" 1/2 (G-M)*	20200637	SP 50-DN65 61 (25) N	Rp 2" 1/2 (G-M)*	20200644
	POWER MAX 6X 130 (115 HI)	672	SP 50-DN65 45 (18) N	Rp 2" 1/2 (G-M)*	20200638	SP 50-DN65 65 (26) N	Rp 2" 1/2 (G-M)*	20200645
	POWER MAX 6X 150	786	SP 50-DN65 51 (21) N	Rp 2" 1/2 (G-M)*	20200640	SP 50-DN65 79 (32) N	Rp 2" 1/2 (G-M)*	20200647
7	POWER MAX 7X 65 P	399	SP 35-DN50 53 (53) N	Rp 2" (G-M)*	20200618	SP 35-DN50 89 (89) N	Rp 2" (G-M)*	20200622
	POWER MAX 7X 80 P	476	SP 35-DN50 71 (71) N	Rp 2" (G-M)*	20200620	SP 35-DN50 101 (101) N	Rp 2" (G-M)*	20200623
	POWER MAX 7X 100	630	SP 50-DN65 41 (17) N	Rp 2" 1/2 (G-M)*	20200637	SP 50-DN65 65 (26) N	Rp 2" 1/2 (G-M)*	20200645
	POWER MAX 7X 110	679	SP 50-DN65 45 (18) N	Rp 2" 1/2 (G-M)*	20200638	SP 50-DN65 71 (29) N	Rp 2" 1/2 (G-M)*	20200646
	POWER MAX 7X 130 (115 HI)	784	SP 50-DN65 51 (21) N	Rp 2" 1/2 (G-M)*	20200640	SP 50-DN65 79 (32) N	Rp 2" 1/2 (G-M)*	20200647
	POWER MAX 7X 150	917	SP 60-DN100 45 (36) N	DN100 - PN16	20200658	SP 60-DN100 67 (54) N	DN100 - PN16	20200665
8	POWER MAX 8X 65 P	456	SP 35-DN50 61 (61) N	Rp 2" (G-M)*	20200619	SP 35-DN50 101 (101) N	Rp 2" (G-M)*	20200623
	POWER MAX 8X 80 P	544	SP 50-DN65 35 (14) N	Rp 2" 1/2 (G-M)*	20200635	SP 50-DN65 55 (22) N	Rp 2" 1/2 (G-M)*	20200642
	POWER MAX 8X 100	720	SP 50-DN65 51 (21) N	Rp 2" 1/2 (G-M)*	20200640	SP 50-DN65 71 (29) N	Rp 2" 1/2 (G-M)*	20200646
	POWER MAX 8X 110	776	SP 50-DN65 55 (22) N	Rp 2" 1/2 (G-M)*	20200642	SP 50-DN65 79 (32) N	Rp 2" 1/2 (G-M)*	20200647
	POWER MAX 8X 130 (115 HI)	896	SP 60-DN100 45 (36) N	DN100 - PN16	20200658	SP 60-DN100 67 (54) N	DN100 - PN16	20200665
	POWER MAX 8X 150	1048	SP 60-DN100 51 (41) N	DN100 - PN16	20200659	SP 60-DN100 77 (62) N	DN100 - PN16	20200667
9	POWER MAX 9X 65 P	513	SP 50-DN65 35 (14) N	Rp 2" 1/2 (G-M)*	20200635	SP 50-DN65 51 (21) N	Rp 2" 1/2 (G-M)*	20200640
	POWER MAX 9X 80 P	612	SP 50-DN65 41 (17) N	Rp 2" 1/2 (G-M)*	20200637	SP 50-DN65 61 (25) N	Rp 2" 1/2 (G-M)*	20200644
	POWER MAX 9X 100	810	SP 60-DN100 41 (33) N	DN100 - PN16	20200648	SP 60-DN100 61 (49) N	DN100 - PN16	20200663
	POWER MAX 9X 110	873	SP 60-DN100 45 (36) N	DN100 - PN16	20200658	SP 60-DN100 67 (54) N	DN100 - PN16	20200665
	POWER MAX 9X 130 (115 HI)	1008	SP 60-DN100 51 (41) N	DN100 - PN16	20200659	SP 60-DN100 77 (62) N	DN100 - PN16	20200667
10	POWER MAX 10X 65 P	570	SP 50-DN65 41 (17) N	Rp 2" 1/2 (G-M)*	20200637	SP 50-DN65 61 (25) N	Rp 2" 1/2 (G-M)*	20200644
	POWER MAX 10X 80 P	680	SP 50-DN65 45 (18) N	Rp 2" 1/2 (G-M)*	20200638	SP 50-DN65 71 (29) N	Rp 2" 1/2 (G-M)*	20200646
	POWER MAX 10X 100	900	SP 60-DN100 45 (36) N	DN100 - PN16	20200658	SP 60-DN100 67 (54) N	DN100 - PN16	20200665
	POWER MAX 10X 110	970	SP 60-DN100 51 (41) N	DN100 - PN16	20200659	SP 60-DN100 77 (62) N	DN100 - PN16	20200667
	POWER MAX 10X 130 (115 HI)	1120	SP 60-DN100 61 (49) N	DN100 - PN16	20200663	SP 60-DN100 87 (70) N	DN100 - PN16	20200670

(\*) G-M: Gas - M

## POWER MAX - CASCADE APPLICATION - SELECTION OF COMPONENTS

### 4.7 SECONDARY CIRCUIT MANAGEMENT

CODE	DESCRIPTION
1220599	Secondary circuit/heater probe <sup>(1)</sup>
20220356	Electronic kit for management of single direct or additional mixed zone (max 16) <sup>(2)</sup>

(1) Probe necessary for the heater or to control the secondary circuit, with temperature alignment with the one set for the primary circuit; probe also necessary to manage the additional mixed zones if secondary boilers (\*) are used to control these zones

(2) Kit required if the number of direct or mixed heating zones is higher than the number of secondary boilers (\*); the kit includes probe code 1220599 required for mixed zone

(\*) All boilers in cascade are considered secondary boilers except one: the one intended to manage the cascade.

Note: for adjusting the ambient temperature use thermostats and chronothermostats.

### 4.8 SEALED CHAMBER CONVERSION KIT (TYPE C)

CODE	DESCRIPTION
20131665	Type C conversion kit for POWER MAX 65 P - 80 P
20131668	Type C conversion kit for POWER MAX 100 - 110 - 130 (115 Hi) - 150

### 4.9 FLUE GAS EXHAUST SYSTEMS

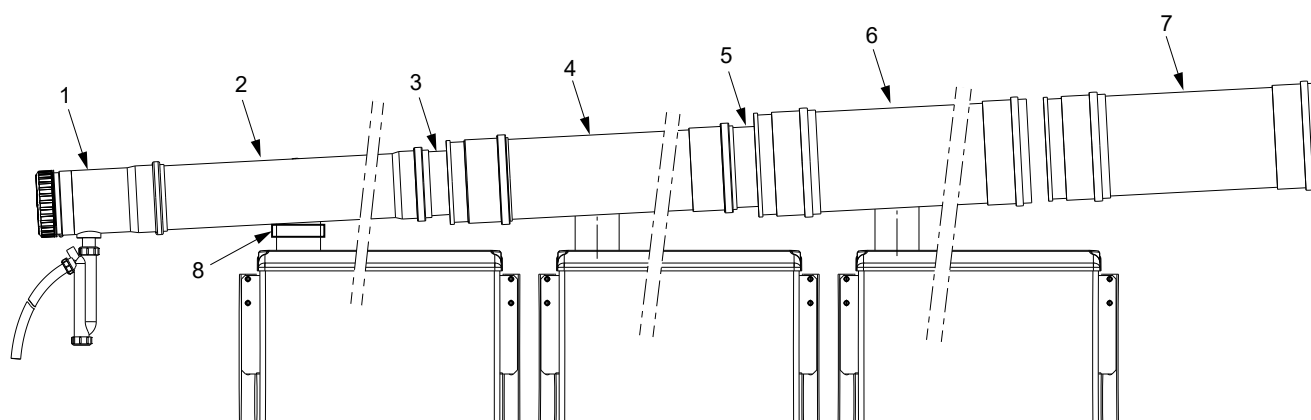

1 Code 20062338 Cascade terminal Ø160 with condensate drainage

2 Code 20131266 Manifold Ø160 for 1 boiler

3 Code 20132391 Eccentric adapter Ø160/200

4 Code 20131901 Manifold Ø200 for 1 boiler

5 Code 20132393 Eccentric adapter Ø200/250

6 Code 20131903 Manifold Ø250 for 1 boiler

7 For BACK-TO-BACK layout only

Code 20132381 - Y fitting Ø160/160

Code 20132384 - Y fitting Ø160/200

Code 20132385 - Y fitting Ø160/250

Code 20132386 - Y fitting Ø200/250

8 Code 20131238 Adapter Ø80/110 (for models 65-80 only)

Modular condensing wall-hung boilers for indoor application

## POWER MAX - CASCADE APPLICATION - SELECTION OF COMPONENTS

### FLUE GAS EXHAUST COLLECTORS Ø 160/200/250 MM FOR ALL POWER MAX MODELS

CODE	DESCRIPTION
20062338	Cascade terminal Ø160 with condensate drain
20131266	Collector Ø160 for 1 boiler
20132391	Eccentric adapter Ø160 / Ø200
20131901	Collector Ø200 for 1 boiler
20132393	Eccentric adapter Ø200 / Ø250
20131903	Collector Ø250 for 1 boiler
20132381	Y connector Ø160 / Ø160 (use only for FRONT - REAR configuration)
20132384	Y connector Ø160 / Ø200 (use only for FRONT - REAR configuration)
20132385	Y connector Ø160 / Ø250 (use only for FRONT - REAR configuration)
20132386	Y connector Ø200 / Ø250 (use only for FRONT - REAR configuration)

#### FRONT CONFIGURATION - MAX 10 BOILERS

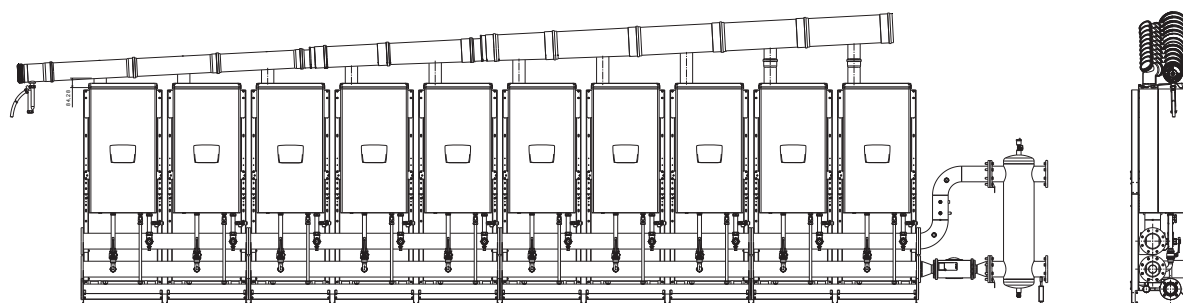

#### BACK-TO-BACK CONFIGURATION - MAX 5 + 5 BOILERS

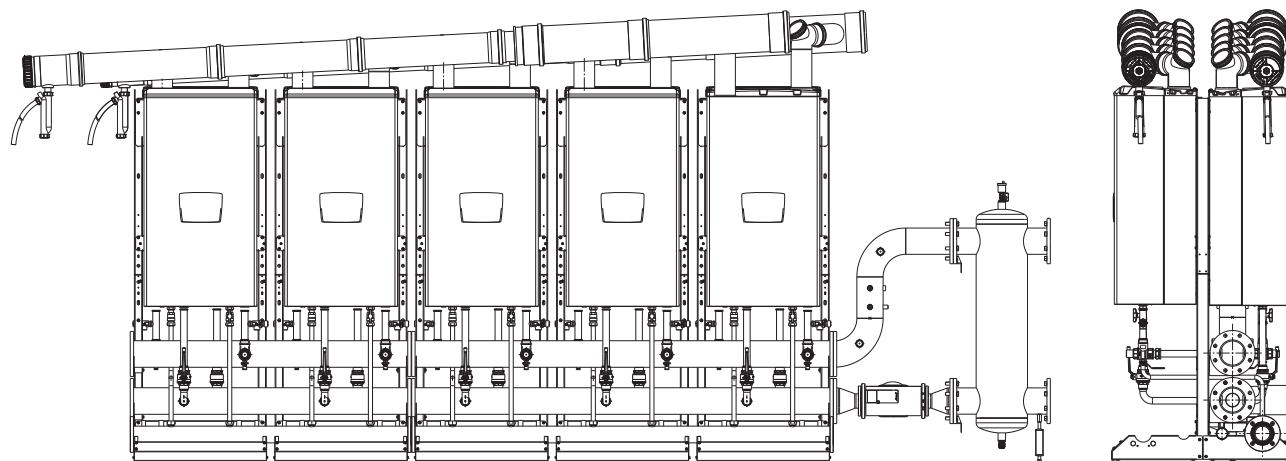

Note: the BACK-TO-BACK configuration has separate lines for each row of boilers, collector side and opposite side.

Modular condensing wall-hung boilers for indoor application

## POWER MAX - CASCADE APPLICATION - SELECTION OF COMPONENTS

### COMBINATION TABLE FOR FLUE GAS COLLECTOR DIAMETERS ACCORDING TO THE NO. OF BOILERS ON A SINGLE COLLECTOR

Model	POWER MAX 65 P	POWER MAX 80 P	POWER MAX 100	POWER MAX 110	POWER MAX 130 (115 Hi)	POWER MAX 150
Heat Input Boiler kW	57	68	90	97	112	131
No. of boilers	DIAMETERS OF FLUE GAS/AIR COLLECTORS					
1	Ø160	Ø160	Ø160	Ø160	Ø160	Ø160
2	Ø160	Ø160	Ø160	Ø160	Ø160	Ø160
3	Ø160	Ø160	Ø160	Ø160	Ø160	Ø160
4	Ø160	Ø160	Ø160	Ø160	Ø160	Ø200
5	Ø160	Ø160	Ø200	Ø200	Ø200	Ø200
6	Ø160	Ø160	Ø200	Ø200	Ø200	Ø250
7	Ø160	Ø200	Ø200	Ø200	Ø250	Ø250
8	Ø200	Ø200	Ø250	Ø250	Ø250	Ø250
9	Ø200	Ø200	Ø250	Ø250	Ø250	-
10	Ø200	Ø200	Ø250	Ø250	Ø250	-

HYBRID SYSTEMS

HEAT PUMPS

WALL HUNG BOILERS

WATER-HEATERS

SOLAR THERMAL UNIT  
AND CYLINDERS

CENTRALIZED  
HEATING

AIR CONDITIONING

TERMINAL UNITS

SYSTEM  
COMPLEMENTARY ITEMS

## POWER MAX - CASCADE APPLICATION - SELECTION OF COMPONENTS

### COLLECTOR CODE SELECTION TABLE ACCORDING TO THE NUMBER OF BOILERS IN FRONT CONFIGURATION

Model	POWER MAX 65 P	POWER MAX 80 P	POWER MAX 100	POWER MAX 110	POWER MAX 130 (115 Hi)	POWER MAX 150
Heat Input Boiler kW	57	68	90	97	112	131
No. of boilers	FLUE GAS COLLECTOR CODE SELECTION FOR FRONT CONFIGURATIONS					
2	2 x 20131238 1 x 20062338 2 x 20131266	2 x 20131238 1 x 20062338 2 x 20131266	1 x 20062338 2 x 20131266	1 x 20062338 2 x 20131266	1 x 20062338 2 x 20131266	1 x 20062338 2 x 20131266
3	3 x 20131238 1 x 20062338 3 x 20131266	3 x 20131238 1 x 20062338 3 x 20131266	1 x 20062338 3 x 20131266	1 x 20062338 3 x 20131266	1 x 20062338 3 x 20131266	1 x 20062338 3 x 20131266
4	4 x 20131238 1 x 20062338 4 x 20131266	4 x 20131238 1 x 20062338 4 x 20131266	1 x 20062338 4 x 20131266	1 x 20062338 4 x 20131266	1 x 20062338 4 x 20131266	1 x 20062338 3 x 20131266 1 x 20132391 1 x 20131901
5	5 x 20131238 1 x 20062338 5 x 20131266	5 x 20131238 1 x 20062338 5 x 20131266	1 x 20062338 4 x 20131266 1 x 20132391 1 x 20131901	1 x 20062338 4 x 20131266 1 x 20132391 1 x 20131901	1 x 20062338 4 x 20131266 1 x 20132391 1 x 20131901	1 x 20062338 3 x 20131266 1 x 20132391 2 x 20131901
6	6 x 20131238 1 x 20062338 6 x 20131266	6 x 20131238 1 x 20062338 6 x 20131266	1 x 20062338 4 x 20131266 1 x 20132391 2 x 20131901	1 x 20062338 4 x 20131266 1 x 20132391 2 x 20131901	1 x 20062338 4 x 20131266 1 x 20132391 2 x 20131901	1 x 20062338 3 x 20131266 1 x 20132391 2 x 20131901 1 x 20132393 1 x 20131903
7	7 x 20131238 1 x 20062338 7 x 20131266	7 x 20131238 1 x 20062338 6 x 20131266 1 x 20132391 1 x 20131901	1 x 20062338 4 x 20131266 1 x 20132391 3 x 20131901	1 x 20062338 4 x 20131266 1 x 20132391 3 x 20131901	1 x 20062338 4 x 20131266 1 x 20132391 2 x 20131901 1 x 20132393 1 x 20131903	1 x 20062338 3 x 20131266 1 x 20132391 2 x 20131901 1 x 20132393 2 x 20131903
8	8 x 20131238 1 x 20062338 7 x 20131266 1 x 20132391 1 x 20131901	8 x 20131238 1 x 20062338 6 x 20131266 1 x 20132391 2 x 20131901	1 x 20062338 4 x 20131266 1 x 20132391 3 x 20131901 1 x 20132393 1 x 20131903	1 x 20062338 4 x 20131266 1 x 20132391 3 x 20131901 1 x 20132393 1 x 20131903	1 x 20062338 4 x 20131266 1 x 20132391 2 x 20131901 1 x 20132393 2 x 20131903	1 x 20062338 3 x 20131266 1 x 20132391 2 x 20131901 1 x 20132393 3 x 20131903
9	9 x 20131238 1 x 20062338 7 x 20131266 1 x 20132391 2 x 20131901	9 x 20131238 1 x 20062338 6 x 20131266 1 x 20132391 3 x 20131901	1 x 20062338 4 x 20131266 1 x 20132391 3 x 20131901 1 x 20132393 2 x 20131903	1 x 20062338 4 x 20131266 1 x 20132391 3 x 20131901 1 x 20132393 2 x 20131903	1 x 20062338 4 x 20131266 1 x 20132391 2 x 20131901 1 x 20132393 3 x 20131903	
10	10 x 20131238 1 x 20062338 7 x 20131266 1 x 20132391 3 x 20131901	10 x 20131238 1 x 20062338 6 x 20131266 1 x 20132391 4 x 20131901	1 x 20062338 4 x 20131266 1 x 20132391 3 x 20131901 1 x 20132393 3 x 20131903	1 x 20062338 4 x 20131266 1 x 20132391 3 x 20131901 1 x 20132393 3 x 20131903	1 x 20062338 4 x 20131266 1 x 20132391 2 x 20131901 1 x 20132393 4 x 20131903	

Note: in case of ducted intake and watertight combustion (type C) double the quantities indicated in the table.

## POWER MAX - CASCADE APPLICATION - SELECTION OF COMPONENTS

### FLUE GAS COLLECTOR CODE SELECTION TABLE ACCORDING TO THE NUMBER OF BOILERS IN BACK-TO-BACK CONFIGURATION

Model	POWER MAX 65 P	POWER MAX 80 P	POWER MAX 100	POWER MAX 110	POWER MAX 130 (115 Hi)	POWER MAX 150
Heat Input Boiler kW	57	68	90	97	112	131
No. of boilers	FLUE GAS COLLECTOR CODE SELECTION FOR BACK-TO-BACK CONFIGURATIONS					
2	2 x 20131238 2 x 20062338 2 x 20131266 1 x 20132381	2 x 20131238 2 x 20062338 2 x 20131266 1 x 20132381	2 x 20062338 2 x 20131266 1 x 20132381	2 x 20062338 2 x 20131266 1 x 20132381	2 x 20062338 2 x 20131266 1 x 20132381	2 x 20062338 2 x 20131266 1 x 20132381
3	3 x 20131238 2 x 20062338 3 x 20131266 1 x 20132381	3 x 20131238 2 x 20062338 3 x 20131266 1 x 20132381	2 x 20062338 3 x 20131266 1 x 20132381	2 x 20062338 3 x 20131266 1 x 20132381	2 x 20062338 3 x 20131266 1 x 20132381	2 x 20062338 3 x 20131266 1 x 20132381
4	4 x 20131238 2 x 20062338 4 x 20131266 1 x 20132381	4 x 20131238 2 x 20062338 4 x 20131266 1 x 20132381	2 x 20062338 4 x 20131266 1 x 20132381	2 x 20062338 4 x 20131266 1 x 20132381	2 x 20062338 4 x 20131266 1 x 20132381	2 x 20062338 4 x 20131266 1 x 20132384
5	5 x 20131238 2 x 20062338 5 x 20131266 1 x 20132381	5 x 20131238 2 x 20062338 5 x 20131266 1 x 20132381	2 x 20062338 5 x 20131266 1 x 20132384	2 x 20062338 5 x 20131266 1 x 20132384	2 x 20062338 5 x 20131266 1 x 20132384	2 x 20062338 5 x 20131266 1 x 20132384
6	6 x 20131238 2 x 20062338 6 x 20131266 1 x 20132381	6 x 20131238 2 x 20062338 6 x 20131266 1 x 20132381	2 x 20062338 6 x 20131266 1 x 20132384	2 x 20062338 6 x 20131266 1 x 20132384	2 x 20062338 6 x 20131266 1 x 20132384	2 x 20062338 6 x 20131266 1 x 20132385
7	7 x 20131238 2 x 20062338 7 x 20131266 1 x 20132381	7 x 20131238 2 x 20062338 7 x 20131266 1 x 20132384	2 x 20062338 7 x 20131266 1 x 20132384	2 x 20062338 7 x 20131266 1 x 20132384	2 x 20062338 7 x 20131266 1 x 20132385	2 x 20062338 5 x 20131266 2 x 20132391 2 x 20131901 1 x 20132386
8	8 x 20131238 2 x 20062338 8 x 20131266 1 x 20132384	8 x 20131238 2 x 20062338 8 x 20131266 1 x 20132384	2 x 20062338 8 x 20131266 1 x 20132385	2 x 20062338 8 x 20131266 1 x 20132385	2 x 20062338 8 x 20131266 1 x 20132385	2 x 20062338 6 x 20131266 2 x 20132391 2 x 20131901 1 x 20132386
9	9 x 20131238 2 x 20062338 9 x 20131266 1 x 20132384	9 x 20131238 2 x 20062338 9 x 20131266 1 x 20132384	2 x 20062338 7 x 20131266 2 x 20132391 2 x 20131901 1 x 20132386	2 x 20062338 7 x 20131266 2 x 20132391 2 x 20131901 1 x 20132386	2 x 20062338 7 x 20131266 2 x 20132391 2 x 20131901 1 x 20132386	-
10	10 x 20131238 2 x 20062338 10 x 20131266 1 x 20132384	10 x 20131238 2 x 20062338 10 x 20131266 1 x 20132384	2 x 20062338 8 x 20131266 2 x 20131901 2 x 20132391 1 x 20132386	2 x 20062338 8 x 20131266 2 x 20131901 2 x 20132391 1 x 20132386	2 x 20062338 8 x 20131266 2 x 20131901 2 x 20132391 1 x 20132386	-

Note: in case of ducted intake and watertight combustion (type C) double the quantities indicated in the table.

## POWER MAX - CASCADE APPLICATION - SELECTION OF COMPONENTS

### 4.10 REMOTE CONTROL

CODE	DESCRIPTION
20213521	POWER MAX remote control kit <sup>(1)</sup>

(1) Necessary for hourly programming of the heater and for programming of zones (also those managed by the additional zone kits)

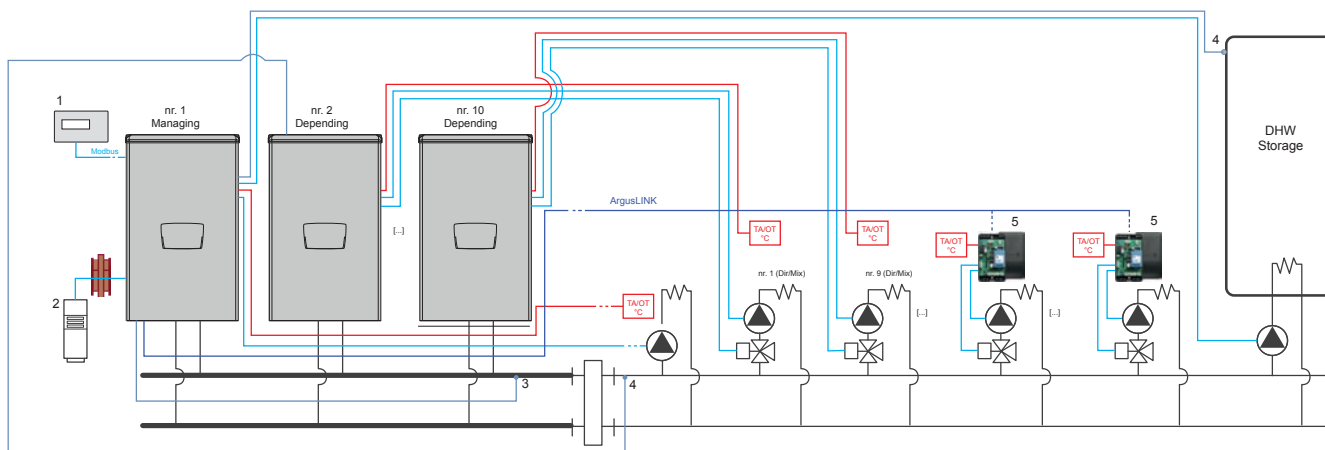

Key to layout

- (1) Remote control kit code 20213521
- (2) External probe code 20132778
- (3) Primary circuit probe code 20175716
- (4) Secondary circuit/heater probe code 1220599
- (5) Heating zone code 20220356

### 4.11 TREATMENT SYSTEMS FOR CONDENSATE NEUTRALIZATION

CODE	DESCRIPTION
4031811	Neutralization kit HN2 up to 270 kW <sup>(1)</sup> <sup>(2)</sup>
4031810	Neutralization kit N2 up to 450 kW <sup>(1)</sup>
4031812	Neutralization kit N3 from 450 to 1500 kW <sup>(1)</sup>
4031813	Neutralization kit HN3 from 270 to 750 kW <sup>(1)</sup> <sup>(2)</sup>

(1) Delivery time of the material if not available in stock: up to 30 working days from order validation date

(2) Equipped with extraction pumps

Modular condensing wall-hung boilers for indoor application

## POWER MAX - CASCADE APPLICATION - SELECTION OF COMPONENTS

HYBRID SYSTEMS

HEAT PUMPS

WALL HUNG BOILERS

WATER-HEATERS

SOLAR THERMAL UNIT AND CYLINDERS

CENTRALIZED HEATING

AIR CONDITIONING

TERMINAL UNITS

SYSTEM COMPLEMENTARY ITEMS

### FRONT FRAME DIMENSIONS

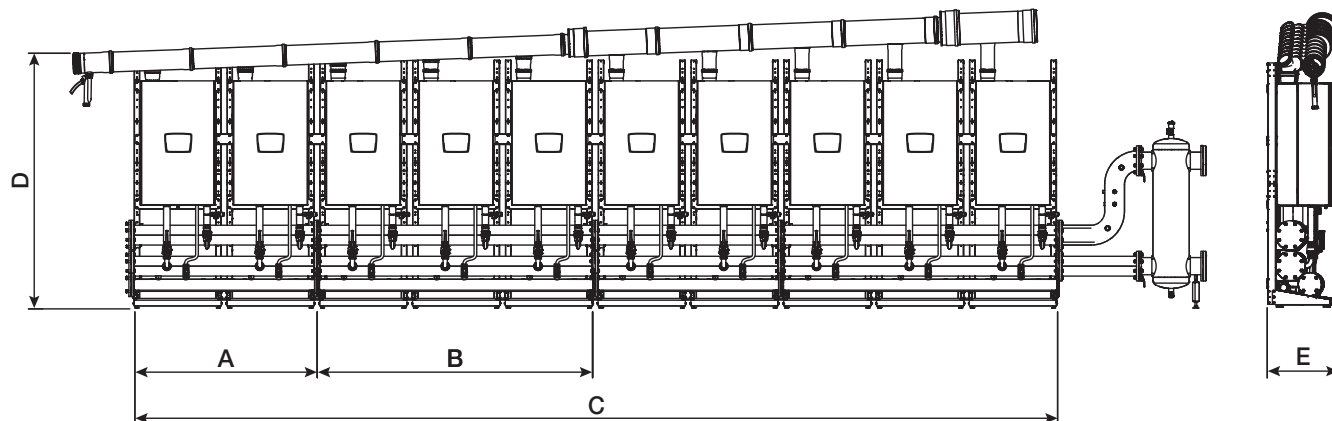

DESCRIPTION		Power Max System					
		65 P	80 P	100	110	130	150
A	mm	1452	1452	1452	1452	1452	1452
B	mm	2245	2245	2245	2245	2245	2245
C (10 modules)	mm	7438	7438	7438	7438	7438	5942 (max 8 modules)
D (10 modules)	mm	2402	2402	2402	2402	2670	2514 (max 8 modules)
E	mm	525	525	525	525	525	525

### FRONT AND REAR FRAME DIMENSIONS

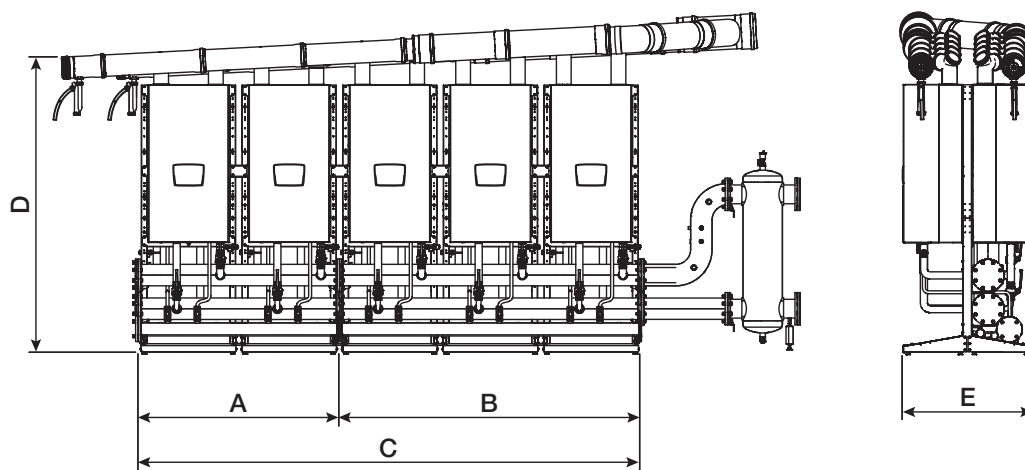

DESCRIPTION		Power Max System					
		65 P	80 P	100	110	130	150
A	mm	1452	1452	1452	1452	1452	1452
B	mm	2245	2245	2245	2245	2245	2245
C (10 modules)	mm	3697	3697	3697	3697	3697	3697 (max 8 modules)
D (10 modules)	mm	2217	2217	2237	2237	2437	2437 (max 8 modules)
E	mm	970	970	970	970	970	970



## POWER MAX BOX



- Indoor thermal modules in cabinet compatible with outdoor installation through optional roof kit
- NEW condensing heat exchanger made of stainless steel
- Total pre-mixing and low polluting emissions: class 6
- Possibility of front cascade up to 1310 kW
- Thermoregulation as standard with optional external probe
- Low-consumption modulating circulating pumps as standard (also with  $\Delta T$  logic)
- Output modulating and modular adjustment
- Automatic reversal (at adjustable time intervals) of burner ignition order
- Simultaneous management of two circuits: heater, high temperature
- Management of up to 16 zones with optional kit
- Automatic summer/winter switch-over
- Anti-legionella function as standard
- Suitable for remote control management (0-10V input or Modbus) with optional kit
- Flue gas wafer check valve built in the boiler
- Optional kit for conversion to watertight chamber
- Standard equipment: electronic management and control adjustment, hydraulic delivery and return collectors, gas, flue gas and condensate drain collectors
- Availability of a wide range of system accessories
- LPG conversion kit supplied as standard



### PRE-MIXED OPEN CHAMBER CONDENSING

CODE	LANGUAGE	MODEL	DIMENSIONS H x W x D (mm)	Delivered output 80°/60° max (kW)	Delivered output 50°/30° max (kW)	Furnace output min-max (kW)
<b>INDOOR CABINETS - WITH MODULATING PUMP</b>						
20141085	IT / EN	POWER MAX BOX 130-2 P(1)	1800 x 900 x 890	111.4	123.8	13.7-114
20162211	PL / RO					
20162231	ES / SI / CR					
20141086	IT / EN	POWER MAX BOX 160-2 P(1)	1800 x 900 x 890	134.0	147.8	13.7-136
20162212	PL / RO					
20162232	ES / SI / CR					
20141087	IT / EN	POWER MAX BOX 200-2 P(1)	1800 x 900 x 890	176.6	194.8	19.4-180
20162213	PL / RO					
20162233	ES / SI / CR					
20141088	IT / EN	POWER MAX BOX 260-2 P(1)	1800 x 900 x 890	219.6	242.2	22.4-223.2
20162214	PL / RO					
20162234	ES / SI / CR					
20141089	IT / EN	POWER MAX BOX 300-2 P(1)(4)	1800 x 900 x 890	258.0	284.2	26.3-262
20162215	PL / RO					
20162235	ES / SI / CR					

## POWER MAX BOX

CODE	LANGUAGE	MODEL	DIMENSIONS H x W x D (mm)	Delivered output 80°/60° max (kW)	Delivered output 50°/30° max (kW)	Furnace output min-max (kW)
20141090	IT / EN	POWER MAX BOX 330-3 P <sup>(2)</sup>	1800 x 1800 x 890	285.9	315.3	19.4-291
20162216	PL / RO					
20162236	ES / SI / CR					
20141091	IT / EN	POWER MAX BOX 390-3 P <sup>(2)</sup>	1800 x 1800 x 890	329.4	363.6	22.4-334.8
20162217	PL / RO					
20162237	ES / SI / CR					
20141092	IT / EN	POWER MAX BOX 450-3 P <sup>(2)</sup> (4)	1800 x 1800 x 890	387.0	426.3	26.3-393
20162218	PL / RO					
20162238	ES / SI / CR					
20141093	IT / EN	POWER MAX BOX 520-4 P <sup>(3)</sup>	1800 x 1800 x 890	439.2	484.4	22.4-446.4
20162219	PL / RO					
20162239	ES / SI / CR					
20141095	IT / EN	POWER MAX BOX 600-4 P <sup>(3)</sup> (4)	1800 x 1800 x 890	516.0	568.4	26.3-524
20162220	PL / RO					
20162240	ES / SI / CR					

Delivery time for products and accessories if not available in stock: up to 30 working days from order validation date.

- (1) Model with 2 heating elements
- (2) Model with 3 heating elements
- (3) Model with 4 heating elements
- (4) Models that can be used for cascade systems

**ATTENTION:** every model is available under different codes, according to the documentation language/s of the instruction manual supplied with the product.

Please select the right code of your model according to the documentation language you need:

- IT / EN (Italian / English)
- PL / RO (Polish / Romanian)
- ES / SI / CR (Spanish / Slovenian / Croatian)

## POWER MAX BOX

### TECHNICAL DRAWINGS

MODEL	DIMENSIONS H x W x D (mm)	ØA (optional) (mm)	ØS (mm)	ØM	ØR	Net weight (kg)
POWER MAX BOX 130-2 P	1800 x 900 x 890	160	160	3"	3"	270
POWER MAX BOX 160-2 P	1800 x 900 x 890	160	160	3"	3"	270
POWER MAX BOX 200-2 P	1800 x 900 x 890	160	160	3"	3"	280
POWER MAX BOX 260-2 P	1800 x 900 x 890	160	160	3"	3"	300
POWER MAX BOX 300-2 P	1800 x 900 x 890	160 (300)	160 (300)	5"	5"	350
POWER MAX BOX 330-3 P	1800 x 1700 x 890	160	160	3"	3"	450
POWER MAX BOX 390-3 P	1800 x 1700 x 890	160	160	3"	3"	490
POWER MAX BOX 450-3 P	1800 x 1700 x 890	160 (300)	160 (300)	5"	5"	540
POWER MAX BOX 520-4 P	1800 x 1700 x 890	160	160	3"	3"	560
POWER MAX BOX 600-4 P	1800 x 1700 x 890	160 (300)	160 (300)	5"	5"	600

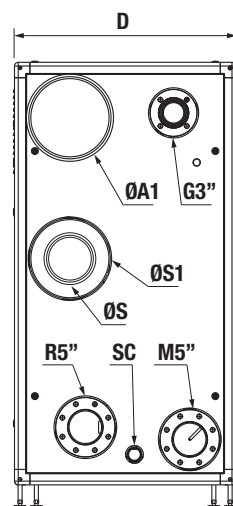
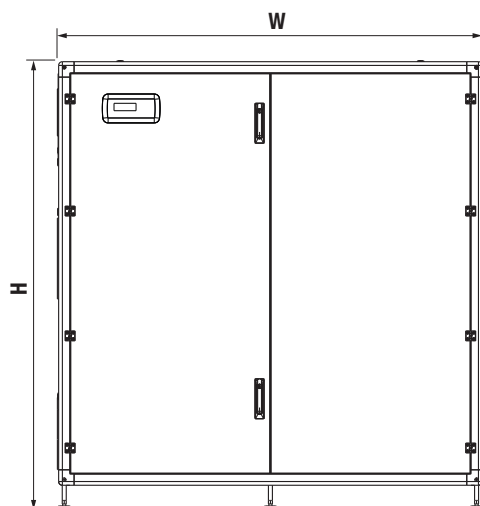
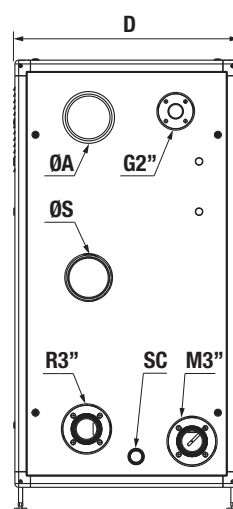
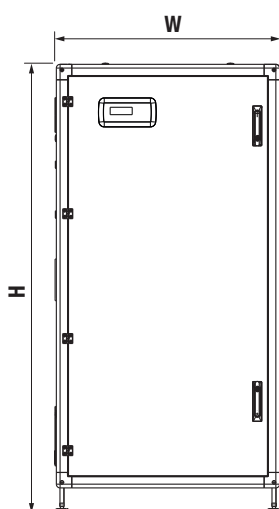

G = GAS  
 M = DELIVERY  
 R = RETURN  
 SC = CONDENSATE DRAIN

**POWER MAX BOX**

**GUIDE TO SYSTEM CONFIGURATION AND SELECTION OF ACCESSORIES**

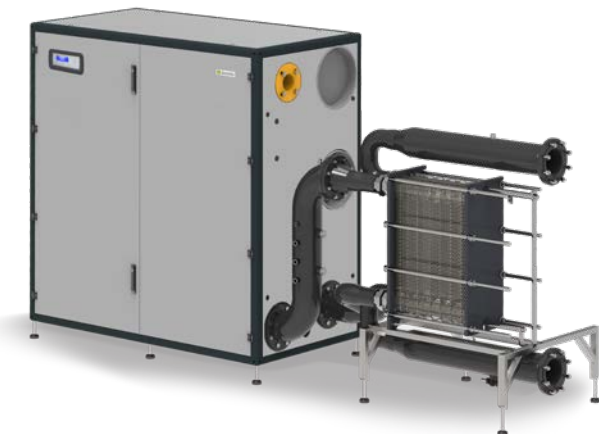

1. BOILER CONFIGURATION

2. SEALED COMBUSTION TRANSFORMATION KIT (TYPE C)

3. HYDRAULIC INTERCEPTION OF THERMAL MODULES

4. MANIFOLDS, SAFETY KITS AND HYDRAULIC ACCESSORIES

5. HYDRAULIC SEPARATORS/PLATE HEAT EXCHANGERS\*

6. AUXILIARY ACCESSORIES FOR TECHNICAL BOX

7. AUXILIARY ACCESSORIES FOR OUTDOOR INSTALLATION

8. SECONDARY CIRCUIT MANAGEMENT ACCESSORIES

9. TREATMENT SYSTEMS FOR CONDENSATE NEUTRALISATION

(\* Configurations with plate heat exchangers: see the product SP - Inspectable plate heat exchanger, section System Complementary Items.

## POWER MAX BOX

### 1. BOILER CONFIGURATION

#### OUTPUT OBTAINABLE WITH STAND ALONE INSTALLATION

Model	POWER MAX BOX									
	130-2 P	160-2 P	200-2 P	260-2 P	300-2 P	330-3 P	390-3 P	450-3 P	520-4 P	600-4 P
Heat Input Boiler kW	114	136	180	224	262	291	336	393	448	524

#### OUTPUT OBTAINABLE WITH CASCADE SYSTEM INSTALLATION

Model	Power kW	POWER MAX BOX									
		130-2 P	160-2 P	200-2 P	260-2 P	300-2 P	330-3 P	390-3 P	450-3 P	520-4 P	600-4 P
POWER MAX BOX 750	655					1			1		
POWER MAX BOX 900	786					1					1
POWER MAX BOX 1050	917								1		1
POWER MAX BOX 1200	1048										2
POWER MAX BOX 1350	1179					1			1		1
POWER MAX BOX 1500	1310					1					2

### 2. SEALED COMBUSTION TRANSFORMATION KIT (TYPE C)

CODE	DESCRIPTION
20145144	Adapter Ø50/80 mm
20145141	Air tube kit for fan/collector connection Ø160 mm
20145137	Air tube kit for fan/collector connection Ø300 mm
20145185	Air collector for models Ø160 mm - for models with 2 thermal modules
20145186	Air collector for models Ø160 mm - for models with 3/4 thermal modules
20145187	Air collector for models Ø300 mm - for models with 2 thermal modules
20145189	Air collector for models Ø300 mm - for models with 3/4 thermal modules

#### SELECTION TABLE OF CODE QUANTITIES ACCORDING TO THE CABINET MODEL FOR WATERTIGHT CONVERSION

Model	20145144	20145141	20145137	20145185	20145186	20145187	20145189
POWER MAX BOX 130-2 P	2x•	2x•		1x•			
POWER MAX BOX 160-2 P	2x•	2x•		1x•			
POWER MAX BOX 200-2 P		2x•		1x•			
POWER MAX BOX 260-2 P		2x•		1x•			
POWER MAX BOX 300-2 P			2x•			1x•	
POWER MAX BOX 330-3 P		3x•					
POWER MAX BOX 390-3 P		3x•					
POWER MAX BOX 450-3 P			3x•				1x•
POWER MAX BOX 520-4 P		4x•					
POWER MAX BOX 600-4 P			4x•				1x•
POWER MAX BOX 750			5x•			1x•	1x•
POWER MAX BOX 900			6x•			1x•	1x•

## POWER MAX BOX

Model	20145144	20145141	20145137	20145185	20145186	20145187	20145189
POWER MAX BOX 1050			7x•				2x•
POWER MAX BOX 1200			8x•				2x•
POWER MAX BOX 1350			9x•			1x•	2x•
POWER MAX BOX 1500			10x•			1x•	2x•

### 3. HYDRAULIC INTERCEPTION OF THERMAL MODULES

CODE	DESCRIPTION
20145170	Hydraulic shut-off kit for single unit with 3-way valve with discharge to atmosphere <sup>(1)</sup>

(1) To be ordered in the same number as the number of units in the system

### 4. MANIFOLDS, SAFETY KITS AND HYDRAULIC ACCESSORIES

CODE	DESCRIPTION
20157593	Junction kit for cascade (Fume Ø300 - Air Ø300 - Condensation Ø50)
20145237	SJunction kit for cascade with spacer (150 mm) <sup>(1)</sup>
20071190	Safety kit <sup>(2)</sup>
20023104	Safety valve up to 460 kW (5.4 bar ØG.¾" F)
20023106	Safety valve up to 580 kW (5.4 bar ØG.1" F)
20009486	Fuel shut-off valve kit (VIC) - ØG.1" <sup>(3)(4)</sup>
20009482	Fuel shut-off valve kit (VIC) - ØG.1" ½ <sup>(4)(5)</sup>
20009483	Fuel shut-off valve kit (VIC) - ØG.2" <sup>(4)(6)</sup>
20061640	Fuel shut-off valve kit (VIC) - ØG.3" <sup>(4)(7)</sup>
20145184	Flanged 3"/2" reduction kit (DN80/DN50)
20094187	Flange kit 2" DN50 PN6 - Gas 2" F
20161191	Flange kit 3" DN80 PN6 - 3" DN80 PN16
20146852	Flanged DN80 to threaded ØG.2" adapter kit for fuel shut-off valve
20145183	Flanged reduction kit DN125/DN80
20147990	2" - 1" ½ gas adapter for VIC valve
20147994	2" - 1" gas adapter for VIC valve
20070903	3" closing plugs kit <sup>(8)</sup>
20070907	5" closing plugs kit <sup>(8)</sup>
20082190	Flange kit 3"
20082191	Flange kit 5"
20167872	Extension kit 3" <sup>(9)(11)</sup>
20167873	Extension kit 5" <sup>(10)(11)</sup>
20145172	Hydraulic flow manifold 3"
20145177	Hydraulic flow manifold 5"

## POWER MAX BOX

CODE	DESCRIPTION
20145181	Hydraulic return manifold 3"
20145182	Hydraulic return manifold 5"

(1) Includes connections H2O 5" - Gas 3" - Flue gas Ø300 - Condensate Ø50.

(2) Does not include safety valve and fuel shut-off valve.

(3) Recommended up to maximum output of 131 kW, calculated considering gas supply pressure = 20 mbar.

(4) Tripping temperature at 97 °C - Capillary length 5 m.

(5) Recommended up to maximum output of 230 kW, calculated considering gas supply pressure = 20 mbar.

(6) Recommended up to maximum output of 580 kW, calculated considering gas supply pressure = 20 mbar.

(7) Recommended up to maximum output of 1310 kW, calculated considering gas supply pressure = 20 mbar.

(8) Kit to close the unused side.

(9) To be installed in case of remote primary/secondary circuit interface with or without technical cabinet up to 485 kW

(10) To be installed in case of remote primary/secondary circuit interface with or without technical cabinet up to 1310 kW

(11) Specific sleeves are provided on the delivery tube for housing devices

Note: for calculation of maximum permissible output of VICs with supply pressure other than 20 mbar, please contact the pre-sales service.

### 5. HYDRAULIC SEPARATORS/PLATE HEAT EXCHANGERS\*

CODE	DESCRIPTION
20145255	Hydraulic separator, 3" connections (up to 485 kW)
20145260	Hydraulic separator, 5" connections (up to 1310 kW)
20145252	LH technical cabinet with hydraulic separator (up to 485 kW) <sup>(1)</sup>
20145254	LH technical cabinet with hydraulic separator (up to 1310 kW) (D) <sup>(1)</sup>
20145247	RH technical cabinet with hydraulic separator (up to 485 kW) <sup>(1)</sup>
20145250	RH technical cabinet with hydraulic separator (up to 1310 kW) (D) <sup>(1)</sup>
20146827	Connection kit for plate exchanger DN80/DN50
20203748	Connection kit for plate exchanger DN125/DN65
20146829	Connection kit for plate exchanger DN125/DN100
20146833	LH technical cabinet for plate exchanger (up to 485 kW)
20203212	LH technical cabinet for plate exchanger (up to 800 kW) (D)
20146836	LH technical cabinet for plate exchanger (up to 1310 kW) (D)
20146830	RH technical cabinet for plate exchanger (up to 485 kW)
20203211	RH technical cabinet for plate exchanger (up to 800 kW) (D)
20146832	RH technical cabinet for plate exchanger (up to 1310 kW) (D)
20158562	RH/LH technical cabinet for housing 3" extension kit (270/485 kW) (D)
20158564	RH/LH technical cabinet for housing 5" extension kit (580/1310 kW) (D)

(D) Availability of the material at our warehouse: 25 working days from the order validation date.

(1) They contain the hydraulic separator.

(\*) Configurations with plate heat exchangers: see the product SP - Inspectable plate heat exchanger, section System Complementary Items.

### SELECTION TABLE FOR CLOSING CAPS, WELD-IN FLANGES AND HYDRAULIC REDUCTIONS

Model	Flanged 5"/3" reduction kit (DN125/DN80)	Closing 3" cap kit	Closing 5" cap kit	Weld-in 3" flange kit	Weld-in 5" flange kit
	20145183	20070903	20070907	20082190	20082191
POWER MAX BOX 130-2 P		1x ■		2x ■	
POWER MAX BOX 160-2 P		1x ■		2x ■	
POWER MAX BOX 200-2 P		1x ■		2x ■	
POWER MAX BOX 260-2 P		1x ■		2x ■	
POWER MAX BOX 300-2 P	2x ■		1x ■	2x ■	
POWER MAX BOX 330-3 P		1x ■		2x ■	
POWER MAX BOX 390-3 P		1x ■		2x ■	

## POWER MAX BOX

	Flanged 5"/3" reduction kit (DN125/DN80)	Closing 3" cap kit	Closing 5" cap kit	Weld-in 3" flange kit	Weld-in 5" flange kit
Model	20145183	20070903	20070907	20082190	20082191
POWER MAX BOX 450-3 P	2x ■		1x ■	2x ■	
POWER MAX BOX 520-4 P		1x ■		2x ■	
POWER MAX BOX 600-4 P			1x ■		2x ■
POWER MAX BOX 750			1x ■		2x ■
POWER MAX BOX 900			1x ■		2x ■
POWER MAX BOX 1050			1x ■		2x ■
POWER MAX BOX 1200			1x ■		2x ■
POWER MAX BOX 1350			1x ■		2x ■
POWER MAX BOX 1500			1x ■		2x ■

### SELECTION TABLE FOR SAFETY DEVICES

Model	Safety devices	Safety valves		Fuel shut-off valves								
	MANDATORY ACCESSORIES safety device kit	MANDATORY ACCESSORIES						ACCESSORIES TO BE SELECTED ACCORDING TO THE INSTALLATION				
		Safety valve up to 460 kW (5.4 bar ØG.¾" F)	Safety valve up to 580 kW (5.4 bar ØG.1" F)	Fuel shut-off valve - ØG.1"	Fuel shut-off valve - ØG.1"½	Fuel shut-off valve - ØG.2"	Fuel shut-off valve - ØG.3"	Without technical cabinet			With separator/exchanger technical cabinet	
								Fanged 3"/2" reduction kit (DN80/DN50)	DN50PN6 2" - 2" G.F flange kit	Flange kit 3" DN80 PN6 - 3" - DN80 PN16	Flanged 3"/2" reduction kit (DN80/DN50)	Flanged DN80/threaded ØG.2" adapter kit for fuel shut-off valve
20071190	20023104	20023106	20009486	20009482	20009483	20061640	20145184	20094187	20161191	20145184	20146852	
POWER MAX BOX 130-2 P	1x ■	1x ■		1x ■								
POWER MAX BOX 160-2 P	1x ■	1x ■			1x ■							
POWER MAX BOX 200-2 P	1x ■	1x ■			1x ■							
POWER MAX BOX 260-2 P	1x ■	1x ■			1x ■							
POWER MAX BOX 300-2 P	1x ■	1x ■				1x ■	1x ■	1x ■		1x ■		
POWER MAX BOX 330-3 P	1x ■	1x ■				1x ■		1x ■				
POWER MAX BOX 390-3 P	1x ■	1x ■				1x ■		1x ■				
POWER MAX BOX 450-3 P	1x ■	1x ■				1x ■	1x ■	1x ■		1x ■		
POWER MAX BOX 520-4 P	1x ■	1x ■				1x ■		1x ■				
POWER MAX BOX 600-4 P	1x ■		1x ■			1x ■	1x ■	1x ■				1x ■
POWER MAX BOX 750	1x ■	2x ■								1x ■		
POWER MAX BOX 900	1x ■	2x ■								1x ■		
POWER MAX BOX 1050	1x ■	2x ■								1x ■		
POWER MAX BOX 1200	1x ■	3x ■								1x ■		
POWER MAX BOX 1350	1x ■	3x ■								1x ■		
POWER MAX BOX 1500	1x ■	3x ■								1x ■		

## POWER MAX BOX

### EXTENSION KIT SELECTION TABLE

Model	WITH/WITHOUT TECHNICAL CABINET			WITH TECHNICAL CABINET		
	3" straight extension kit with pockets	5" straight extension kit with pockets	RH/LH technical cabinet for housing 3" extension kit	RH/LH technical cabinet for housing 5" extension kit	Gas adapter 2" - 1" and 1/2 for fuel shut-off valve	Gas adapter 2" - 1" for fuel shut-off valve
	20167872	20167873	20158562	20158564	20147990	20147994
POWER MAX BOX 130-2 P	■		■			■
POWER MAX BOX 160-2 P	■		■		■	
POWER MAX BOX 200-2 P	■		■		■	
POWER MAX BOX 260-2 P	■		■		■	
POWER MAX BOX 300-2 P	■		■			
POWER MAX BOX 330-3 P	■		■			
POWER MAX BOX 390-3 P	■		■			
POWER MAX BOX 450-3 P	■		■			
POWER MAX BOX 520-4 P	■		■			
POWER MAX BOX 600-4 P		■		■		
POWER MAX BOX 750		■		■		
POWER MAX BOX 900		■		■		
POWER MAX BOX 1050		■		■		
POWER MAX BOX 1200		■		■		
POWER MAX BOX 1350		■		■		
POWER MAX BOX 1500		■		■		

### TECHNICAL CABINET SELECTION TABLE FOR EXTENSION HOUSING

Model	RH/LH technical cabinet for housing 3" extension kit		RH/LH technical cabinet for housing 5" extension kit	
	20158562		20158564	
POWER MAX BOX 130-2 P	■			
POWER MAX BOX 160-2 P	■			
POWER MAX BOX 200-2 P	■			
POWER MAX BOX 260-2 P	■			
POWER MAX BOX 300-2 P	■			
POWER MAX BOX 330-3 P	■			
POWER MAX BOX 390-3 P	■			
POWER MAX BOX 450-3 P	■			
POWER MAX BOX 520-4 P	■			
POWER MAX BOX 600-4 P			■	
POWER MAX BOX 750			■	
POWER MAX BOX 900			■	
POWER MAX BOX 1050			■	
POWER MAX BOX 1200			■	
POWER MAX BOX 1350			■	
POWER MAX BOX 1500			■	

## POWER MAX BOX

**HYDRAULIC SEPARATOR AND HYDRAULIC ACCESSORIES SELECTION TABLE**

Model	Without technical cabinet							With technical cabinet			
	Left/right side installation							Installation left side		Installation right side	
	3" connections up to 485 kW	5" connections up to 1310 kW	3" delivery stub pipe kit	5" delivery stub pipe kit	3" return stub pipe kit	5" return stub pipe kit	B2B cascade hydraulic connection kit	LH technical cabinet for hydraulic separator up to 485 kW	LH technical cabinet for hydraulic separator up to 1310 kW	RH technical cabinet for hydraulic separator up to 485 kW	RH technical cabinet for hydraulic separator up to 1310 kW
	20145255	20145260	20145172	20145177	20145181	20145182	20162865	20145252	20145254	20145247	20145250
POWER MAX BOX 130-2 P	■		■		■			■		■	
POWER MAX BOX 160-2 P	■		■		■			■		■	
POWER MAX BOX 200-2 P	■		■		■			■		■	
POWER MAX BOX 260-2 P	■		■		■			■		■	
POWER MAX BOX 300-2 P	■		■		■			■		■	
POWER MAX BOX 330-3 P	■		■		■			■		■	
POWER MAX BOX 390-3 P	■		■		■			■		■	
POWER MAX BOX 450-3 P	■		■		■			■		■	
POWER MAX BOX 520-4 P	■		■		■			■		■	
POWER MAX BOX 600-4 P		■		■		■			■		■
POWER MAX BOX 750		■		■		■			■		■
POWER MAX BOX 900		■		■		■			■		■
POWER MAX BOX 1050		■		■		■			■		■
POWER MAX BOX 1200		■		■		■			■		■
POWER MAX BOX 1350		■		■		■			■		■
POWER MAX BOX 1500		■		■		■			■		■

**PLATE HEAT EXCHANGER COMBINATIONS FOR BOILER OPERATION AT NOMINAL OR MAXIMUM FLOW RATE (ΔT = 10 °C AVERAGE BETWEEN PRIMARY AND SECONDARY)**

MODEL	Plate Heat Exchangers ΔTml = 10° C												
	SP 35-DN50 21 (21) N	SP 35-DN50 27 (27) N	SP 35-DN50 33 (33) N	SP 35-DN50 41 (41) N	SP 35-DN50 53 (53) N	SP 35-DN50 61 (61) N	SP 50-DN65 35 (14) N	SP 50-DN65 45 (18) N	SP 50-DN65 51 (21) N	SP 60-DN100 41 (33) N	SP 60-DN100 45 (36) N	SP 60-DN100 51 (41) N	SP 60-DN100 61 (49) N
POWER MAX BOX 130-2 P	■												
POWER MAX BOX 160-2 P	■												
POWER MAX BOX 200-2 P		■											
POWER MAX BOX 260-2 P			■										

## POWER MAX BOX

MODEL	Plate Heat Exchangers $\Delta T_{ml} = 10^\circ \text{C}$												
	SP 35-DN50 21 (21) N	SP 35-DN50 27 (27) N	SP 35-DN50 33 (33) N	SP 35-DN50 41 (41) N	SP 35-DN50 53 (53) N	SP 35-DN50 61 (61) N	SP 50-DN65 35 (14) N	SP 50-DN65 45 (18) N	SP 50-DN65 51 (21) N	SP 60-DN100 41 (33) N	SP 60-DN100 45 (36) N	SP 60-DN100 51 (41) N	SP 60-DN100 61 (49) N
	20200611	20200613	20200614	20200615	20200618	20200619	20200635	20200638	20200640	20200648	20200658	20200659	20200663
POWER MAX BOX 300-2 P			■										
POWER MAX BOX 330-3 P				■									
POWER MAX BOX 390-3 P				■									
POWER MAX BOX 450-3 P					■								
POWER MAX BOX 520-4 P						■							
POWER MAX BOX 600-4 P							■						
POWER MAX BOX 750								■					
POWER MAX BOX 900									■				
POWER MAX BOX 1050										■			
POWER MAX BOX 1200											■		
POWER MAX BOX 1350												■	
POWER MAX BOX 1500													■

### PLATE HEAT EXCHANGER COMBINATIONS FOR BOILER OPERATION AT NOMINAL OR MAXIMUM FLOW RATE ( $\Delta T = 7,2^\circ \text{C}$ AVERAGE BETWEEN PRIMARY AND SECONDARY)

MODEL	Plate Heat Exchangers $\Delta T_{ml} = 7,2^\circ \text{C}$														
	SP 35-DN50 27 (27) N	SP 35-DN50 33 (33) N	SP 35-DN50 41 (41) N	SP 35-DN50 53 (53) N	SP 35-DN50 61 (61) N	SP 35-DN50 71 (71) N	SP 35-DN50 81 (81) N	SP 35-DN50 89 (89) N	SP 35-DN50 101 (101) N	SP 50-DN65 55 (22) N	SP 50-DN65 65 (26) N	SP 50-DN65 79 (32) N	SP 60-DN100 61 (49) N	SP 60-DN100 77 (62) N	SP 60-DN100 87 (70) N
	20200613	20200614	20200615	20200618	20200619	20200620	20200621	20200622	20200623	20200642	20200645	20200647	20200663	20200667	20200670
POWER MAX BOX 130-2 P	■														
POWER MAX BOX 160-2 P		■													
POWER MAX BOX 200-2 P			■												
POWER MAX BOX 260-2 P				■											
POWER MAX BOX 300-2 P					■										
POWER MAX BOX 330-3 P						■									
POWER MAX BOX 390-3 P							■								
POWER MAX BOX 450-3 P								■							
POWER MAX BOX 520-4 P									■						
POWER MAX BOX 600-4 P										■					
POWER MAX BOX 750											■				
POWER MAX BOX 900												■			
POWER MAX BOX 1050													■		
POWER MAX BOX 1200														■	
POWER MAX BOX 1350															■
POWER MAX BOX 1500															■

## POWER MAX BOX

**HYDRAULIC ACCESSORIES SELECTION TABLE FOR PLATE EXCHANGER INSTALLATION**

Model	Without technical cabinet			With technical cabinet					
	Connection kit for plate exchanger DN80 (Ø3") /DN50	Connection kit for plate exchanger DN125 (Ø5")/DN65	Connection kit for plate exchanger DN125 (Ø5")/DN100	Left side installation			Right side installation		
				LH technical cabinet for plate exchanger up to 485 kW	LH technical cabinet for plate exchanger up to 800 kW	LH technical cabinet for plate exchanger up to 1310 kW	"RH technical cabinet for plate exchanger up to 485 kW"	RH technical cabinet for plate exchanger up to 800 kW	RH technical cabinet for plate exchanger up to 1310 kW
20146827	20203748	20146829	20146833	20203212	20146836	20146830	20203211	20146832	
POWER MAX BOX 130-2 P	■			■			■		
POWER MAX BOX 160-2 P	■			■			■		
POWER MAX BOX 200-2 P	■			■			■		
POWER MAX BOX 260-2 P	■			■			■		
POWER MAX BOX 300-2 P	■			■			■		
POWER MAX BOX 330-3 P	■			■			■		
POWER MAX BOX 390-3 P	■			■			■		
POWER MAX BOX 450-3 P	■			■			■		
POWER MAX BOX 520-4 P	■			■			■		
POWER MAX BOX 600-4 P		■			■			■	
POWER MAX BOX 750		■			■			■	
POWER MAX BOX 900		■			■			■	
POWER MAX BOX 1050			■			■			■
POWER MAX BOX 1200			■			■			■
POWER MAX BOX 1350			■			■			■
POWER MAX BOX 1500			■			■			■

## POWER MAX BOX

### 6. AUXILIARY ACCESSORIES FOR TECHNICAL BOX

CODE	DESCRIPTION
20147030	Technical cabinet air/flue gas collector L = 900 mm Ø160 mm <sup>(1)</sup>
20147028	Technical cabinet air/flue gas collector L = 900 mm Ø300 mm <sup>(1)</sup>
20157595	Technical cabinet air/flue gas collector L = 1800 mm Ø160 mm <sup>(1)</sup>
20157598	Technical cabinet air/flue gas collector L = 1800 mm Ø300 mm <sup>(1)</sup>
20157599	Technical cabinet flue gas "S" collector L = 1800 mm Ø300 mm (SP60-DN100) <sup>(1)</sup>
20146844	Top lifting kit
20146845	Moving wheel kit <sup>(2)</sup>
20146846	Internal light kit for emergency and service

(1) To be used as indicated in the tables below.

(2) To be used during installation.

### OPEN CHAMBER BOILER CONFIGURATION

Selection table	Flue gas exhaust side	Technical cabinet side
Table A	RH	RH
	LH	LH
Collectors not required	LH	RH
	RH	LH

### WATERTIGHT CHAMBER BOILER CONFIGURATION

Selection table	Flue gas exhaust side	Air intake side	Technical cabinet side
Table A	RH	RH	RH
	LH	LH	LH
Table B	LH	RH	RH
	LH	RH	LH
	RH	LH	RH
	RH	LH	LH
	LH	LH	RH
Collectors not required	RH	RH	LH

## POWER MAX BOX

**TABLE A**

Air/flue gas collector code and number	Technical cabinet for housing of extensions or empty technical cabinet				Technical cabinet for hydraulic separator				Technical cabinet for heat exchanger					
	Open chamber		Water-tight chamber		Open chamber		Water-tight chamber		Camera aperta			Camera stagna		
	20147030	20147028	20147030	20147028	20147030	20147028	20147030	20147028	20157595	20157598	20157599	20157595	20157598	20157599
POWER MAX BOX 130-2 P	1x		2x		1x		2x		1x			2x		
POWER MAX BOX 160-2 P	1x		2x		1x		2x		1x			2x		
POWER MAX BOX 200-2 P	1x		2x		1x		2x		1x			2x		
POWER MAX BOX 260-2 P	1x		2x		1x		2x		1x			2x		
POWER MAX BOX 300-2 P (*)	1x				1x				1x					
POWER MAX BOX 330-3 P	1x		2x		1x		2x		1x			2x		
POWER MAX BOX 390-3 P	1x		2x		1x		2x		1x			2x		
POWER MAX BOX 450-3 P (*)	1x				1x				1x					
POWER MAX BOX 520-4 P	1x		2x		1x		2x		1x			2x		
POWER MAX BOX 600-4 P		1x		2x		1x		2x		1x			2x	
POWER MAX BOX 750		1x		2x		1x		2x		1x			2x	
POWER MAX BOX 900		1x		2x		1x		2x		1x			2x	
POWER MAX BOX 1050		1x		2x		1x		2x			1x			(**)
POWER MAX BOX 1200		1x		2x		1x		2x			1x			(**)
POWER MAX BOX 1350		1x		2x		1x		2x			1x			(**)
POWER MAX BOX 1500		1x		2x		1x		2x			1x			(**)

NOTE: to be used only if the outlet on flue gas side is the same as the outlet on the hydraulic side

(\*) Flue gas exhaust/air intake on technical cabinet side not available in case of watertight installation, air intake on the boiler side mandatory.

(\*\*) In case of technical cabinet with heat exchanger and watertight installation, the air intake must be on the machine side and not on the technical cabinet side.

In this case, also for the pump technical cabinet, if present, it is necessary to use only one code 20147028.

**TABLE B**

Air/flue gas collector code and number	Technical cabinet for housing of extensions or empty technical cabinet				Technical cabinet for hydraulic separator				Technical cabinet for heat exchanger					
	Open chamber		Water-tight chamber		Open chamber		Water-tight chamber		Camera aperta			Camera stagna		
	20147030	20147028	20147030	20147028	20147030	20147028	20147030	20147028	20157595	20157598	20157599	20157595	20157598	20157599
POWER MAX BOX 130-2 P	1x		1x		1x		1x		1x			1x		
POWER MAX BOX 160-2 P	1x		1x		1x		1x		1x			1x		
POWER MAX BOX 200-2 P	1x		1x		1x		1x		1x			1x		
POWER MAX BOX 260-2 P	1x		1x		1x		1x		1x			1x		
POWER MAX BOX 300-2 P (*)	1x		1x		1x		1x		1x			1x		
POWER MAX BOX 330-3 P	1x		1x		1x		1x		1x			1x		
POWER MAX BOX 390-3 P	1x		1x		1x		1x		1x			1x		
POWER MAX BOX 450-3 P (*)	1x		1x		1x		1x		1x			1x		
POWER MAX BOX 520-4 P	1x		1x		1x		1x		1x			1x		
POWER MAX BOX 600-4 P		1x		1x		1x		1x		1x			1x	
POWER MAX BOX 750		1x		1x		1x		1x		1x			1x	
POWER MAX BOX 900		1x		1x		1x		1x		1x			1x	
POWER MAX BOX 1050		1x		1x		1x		1x			1x			1x
POWER MAX BOX 1200		1x		1x		1x		1x			1x			1x
POWER MAX BOX 1350		1x		1x		1x		1x			1x			1x
POWER MAX BOX 1500		1x		1x		1x		1x			1x			1x

## POWER MAX BOX

### 7. AUXILIARY ACCESSORIES FOR OUTDOOR INSTALLATION

CODE	DESCRIPTION
20146841	Roof kit for cabinet outdoor installation L = 900 mm
20146842	Roof kit for cabinet outdoor installation L = 1800 mm
20146843	Kit IPX5D display coverage
20146953	Outdoor insulation kit for 3" blind flanges
20146954	Outdoor insulation kit for 5" blind flanges

NOTE: to be used only in case of outdoor installation.

#### ROOF SELECTION TABLE FOR OUTDOOR INSTALLATION

Model	Configuration with technical cabinet for hydraulic separator or empty technical cabinet					Configuration with technical cabinet for plate exchanger				
	20146841	20146842	20146843	20146953	20146954	20146841	20146842	20146843	20146953	20146954
POWER MAX BOX 130-2 P	2x ■		1x ■	1x ■		1x ■	1x ■	1x ■	1x ■	
POWER MAX BOX 160-2 P	2x ■		1x ■	1x ■		1x ■	1x ■	1x ■	1x ■	
POWER MAX BOX 200-2 P	2x ■		1x ■	1x ■		1x ■	1x ■	1x ■	1x ■	
POWER MAX BOX 260-2 P	2x ■		1x ■	1x ■		1x ■	1x ■	1x ■	1x ■	
POWER MAX BOX 300-2 P (*)	2x ■		1x ■		1x ■	1x ■	1x ■	1x ■		1x ■
POWER MAX BOX 330-3 P	1x ■	1x ■	1x ■	1x ■			2x ■	1x ■	1x ■	
POWER MAX BOX 390-3 P	1x ■	1x ■	1x ■	1x ■			2x ■	1x ■	1x ■	
POWER MAX BOX 450-3 P (*)	1x ■	1x ■	1x ■		1x ■		2x ■	1x ■		1x ■
POWER MAX BOX 520-4 P	1x ■	1x ■	1x ■	1x ■			2x ■	1x ■	1x ■	
POWER MAX BOX 600-4 P	1x ■	1x ■	2x ■		1x ■		2x ■	2x ■		1x ■
POWER MAX BOX 750	2x ■	1x ■	2x ■		1x ■	1x ■	2x ■	2x ■		1x ■
POWER MAX BOX 900	2x ■	1x ■	2x ■		1x ■	1x ■	2x ■	2x ■		1x ■
POWER MAX BOX 1050	1x ■	2x ■	2x ■		1x ■		3x ■	2x ■		1x ■
POWER MAX BOX 1200	1x ■	2x ■	2x ■		1x ■		3x ■	2x ■		1x ■
POWER MAX BOX 1350	2x ■	2x ■	3x ■		1x ■	1x ■	3x ■	3x ■		1x ■
POWER MAX BOX 1500	2x ■	2x ■	3x ■		1x ■	1x ■	3x ■	3x ■		1x ■

**POWER MAX BOX**

**8. SECONDARY CIRCUIT MANAGEMENT ACCESSORIES**

CODE	DESCRIPTION
1220599	Secondary circuit/heater probe
20220356	Electronic kit for management of direct or additional mixed zone (max 16) <sup>(1)</sup>
20132778	External probe

(1) Used for secondary circuit and heater management.

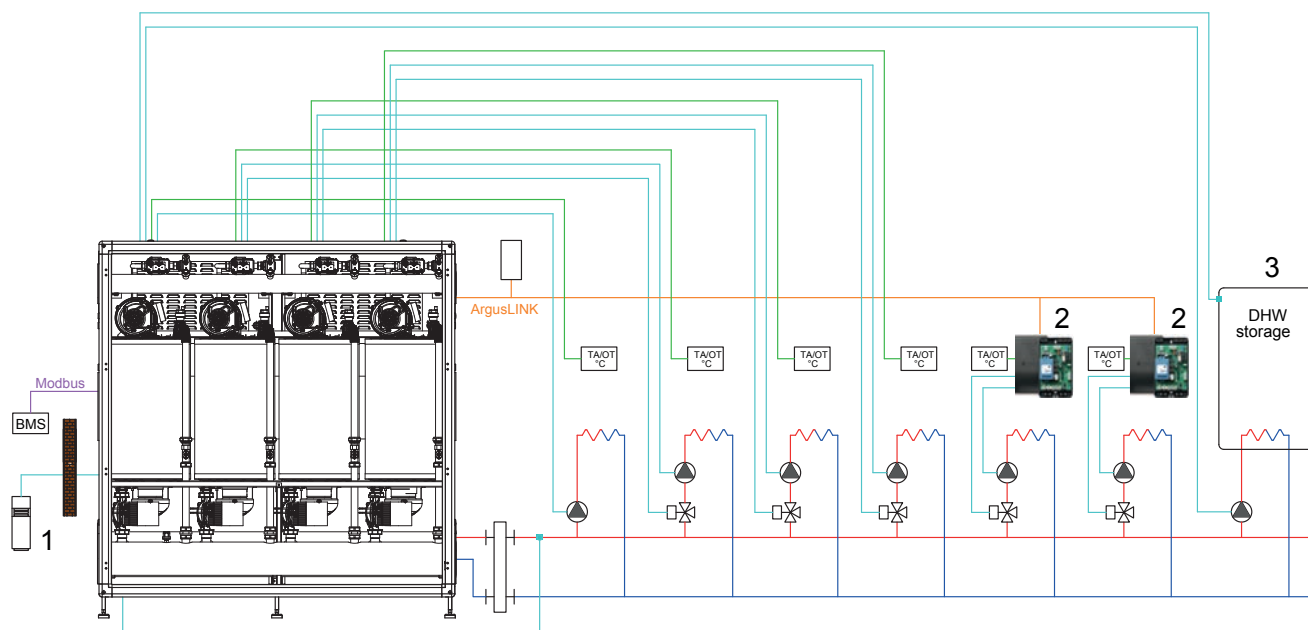

- (1) External probe
- (2) Electronic kit for management of direct or additional mixed zone
- (3) Heater probe

**9. TREATMENT SYSTEMS FOR CONDENSATE NEUTRALIZATION**











CODE	DESCRIPTION
4031810	Neutralization kit N2 up to 450 kW
4031812	Neutralization kit N3 from 450 to 1500 kW <sup>(1)</sup>
4031811	Neutralization kit HN2 up to 270 kW <sup>(2)</sup>
4031813	Neutralization kit HN3 from 270 to 750 kW <sup>(1) (2)</sup>

(1) Delivery time of the material if not available in stock: up to 30 working days from order validation date

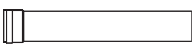
(2) Equipped with extraction pumps

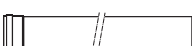
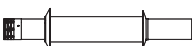
**SINGLE FLUE GAS EXHAUST SYSTEM OR DOUBLE SUCTION/DISCHARGE Ø80 MM**

CODE	DESCRIPTION	Material (*)	POWER EVO-X 50 DEP/50	POWER EVO-X 65/80	POWER MAX 65 P - 80 P	IMAGE
20134830	Flue adapter kit from Ø60/100 to Ø80+80	PP (1)	■			
20190475	Compact adjustable splitter device kit from Ø60/100 to Ø80/80	PP (1)	■			
20129765	Flue adapter kit from Ø60/100 to Ø80+80	PP (1)	■			
20129769	Vertical flue adapter kit from Ø60/100 to Ø80 (for type B23 installation) for outdoor	PP (1)	■	■		
20196312	Adapter from Ø 80/125 mm to Ø80/80 mm	PP (1)		■		
20196315	Ø80/80 - Rainproof vertical adapter	PP (1)		■		
20131271	Flue cover Ø80 for rigid/flexible system	PP (1)	■	■	■	
20132504	T-junction kit Ø80 mm with support bracket	PP (1)	■	■	■	
20132505	Pipe spacers in the flue gases pipe	PP (1)	■	■	■	
20132506	Straight inspection manifold Ø80 mm	PP (1)	■	■	■	
20132508	Flue cover Ø80 mm	PP (1)	■	■	■	
20132509	Flexible extension 12.5 m with 8 spacers Ø80 mm	PP (1)	■	■	■	
20132510	Rigid-flexible fitting Ø80 mm	PP (1)	■	■	■	
20132511	Flexible-flexible fitting Ø80 mm	PP (1)	■	■	■	
20132512	Flexible-rigid-fitting Ø80 mm	PP (1)	■	■	■	

CODE	DESCRIPTION	Material (*)	POWER EVO-X 50 DEP/50	POWER EVO-X 65/80	POWER MAX 65 P - 80 P	IMAGE
20132513	Ø80 mm T-junction kit	PP (1)	■	■	■	
20132518	Drain pipe kit	PP (1)	■	■	■	
20137503	45° bend Ø80 mm	PP (1)	■	■	■	
20137506	90° bend Ø80 mm	PP (1)	■	■	■	
20137508	Extension Ø80 mm, L=500	PP (1)	■	■	■	
20137509	Extension Ø80 mm L=1000	PP (1)	■	■	■	
20137511	Extension Ø80 mm L=2000	PP (1)	■	■	■	
20137515	Air suction terminal Ø80 mm	PP (1)	■	■	■	
20137517	Horizontal terminal Ø80 mm	PP (1)	■	■	■	
20132514	Ø80 mm T-junction closure kit for condensate drain	MET (1)	■	■	■	
20137538	Air inlet kit for installation type B23	MET	■	■	■	
20145888	Flue support shelf kit	MET	■	■	■	

(\*) PP material: colour may change over time because of sun's rays exposure.









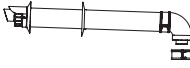

(1) H1 pressure level according to EN 1443.

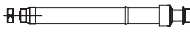
NOTE: if in the flue line there is a component with P1 pressure level (according to EN 1443), all the line has P1 pressure level even if all the other components are in H1 pressure level (according to EN 1443).

NOTE: please, refer to boiler installation manual for maximum flue line length.

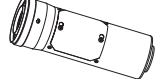
Deductible products only in the context of the refurbishment of the system or the energy-efficient retrofitting of the building. Therefore please always check the specific ways of accessing the incentive.

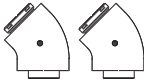
**Ø60/100 MM CONCENTRIC FLUE GAS EXHAUST SUCTION/DISCHARGE SYSTEM**

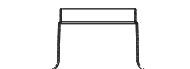
CODE	DESCRIPTION	Material (*)	POWER EVO-X 50 DEP/50	POWER MAX 65 P - 80 P	IMAGE
20137535	Double adaptor Ø80/80 mm - concentric Ø60/100 mm	PP/MET (1)2	■	■	
20132018	Wall collector Ø60/100 mm	PP/PPu (1)2	■	■	
20142835	Ø60/100 Concentric extension with inspection	PP/PPu (1)2	■	■	
20142828	Ø60/100 90° Concentric bend with inspection	PP/PPu (1)2	■	■	
20132020	Ø60/100 Vertical flue terminal Ø125 external straight pipe	PP/PPu (1)2	■	■	
20132043	Ø60/100 Concentric extension 500 mm	PP/PPu (1)2	■	■	
20132044	Ø60/100 Concentric extension 1000 mm	PP/PPu (1)2	■	■	
20132045	Ø60/100 Concentric extension 2000 mm	PP/PPu (1)2	■	■	
20132015	Ø60/100 Extention with inspection door	PP/PPu (1)2	■	■	
20132012	Ø60/100 45° Concentric bend	PP/PPu (1)2	■	■	
20132040	Ø60/100 45° Concentric bend (2 pcs.)	PP/PPu (1)2	■	■	
20132013	Ø60/100 90° Concentric bend	PP/PPu (1)2	■	■	
20132050	Ø125 Pitched roof tile for vertical flue	PP/PPu (1)2	■	■	
20135579	Flat roof tile for vertical flue	PP/PPu (1)2	■	■	

CODE	DESCRIPTION	Material (*)	POWER EVO-X 50 DEP/50	POWER MAX 65 P - 80 P	IMAGE
20135584	Ø100 Spacers for pipe (4 pcs. pack)	PP/PPu (1)(2)	■	■	
20163032	Ø100 Pipe clips kit (5 pcs)	PP/PPu (1)(2)	■	■	

(\*) PP material: colour may change over time because of sun's rays exposure.

(1) H1 pressure level according to EN 1443.











(2) Check the maximum equivalent lengths by consulting the technical data sheet and / or by contacting the pre-sales service.

NOTE: if in the flue line there is a component with P1 pressure level (according to EN 1443), all the line has P1 pressure level even if all the other components are in H1 pressure level (according to EN 1443).

NOTE: please, refer to boiler installation manual for maximum flue line length.

Deductible products only in the context of the refurbishment of the system or the energy-efficient retrofitting of the building. Therefore please always check the specific ways of accessing the incentive.

**Ø80/125 MM CONCENTRIC FLUE GAS EXHAUST SUCTION/DISCHARGE SYSTEM**

CODE	DESCRIPTION	Material (*)	POWER EVO-X 50 DEP/50	POWER EVO-X 65/80	POWER MAX 65 P - 80 P	IMAGE
20131054	45° bend Ø80/125 mm	PP/ABS (1)	■	■	■	
20131055	Double adaptor Ø80/80 mm - concentric Ø80/125 mm	PP/ABS (1)	■	■	■	
20131083	90° bend Ø80/125 mm	PP/ABS (1)	■	■	■	
20131084	Extension Ø80/125 mm, L=500 mm	PP/ABS (1)	■	■	■	
20131085	Extension Ø80/125 mm, L=1000 mm	PP/ABS (1)	■	■	■	
20131095	90° bend with inspection Ø80/125 mm	PP/ABS (1)	■	■	■	
20131098	Wall discharge terminal Ø80/125 mm	PP/ABS (1)	■	■	■	
20131113	Vertical terminal Ø80/125 mm	PP/ABS	■	■	■	
20132050	Universal tile for sloping roofs	Nylon	■	■	■	
20132520	Element kit Ø80/125 mm connection to flue	PP (1)	■	■	■	
20135579	Flat roof tile for vertical flue		■	■	■	

(\*) PP material: colour may change over time because of sun's rays exposure.









(1) H1 pressure level according to EN 1443.

NOTE: if in the flue line there is a component with P1 pressure level (according to EN 1443), all the line has P1 pressure level even if all the other components are in H1 pressure level (according to EN 1443).

NOTE: please, refer to boiler installation manual for maximum flue line length.

Deductible products only in the context of the refurbishment of the system or the energy-efficient retrofitting of the building. Therefore please always check the specific ways of accessing the incentive.

**SINGLE FLUE GAS EXHAUST SYSTEM OR DOUBLE SUCTION/DISCHARGE Ø110 MM**

CODE	DESCRIPTION	Material (*)	POWER MAX 100 - 150	IMAGE
20131202	90° bend Ø110 mm with inspection	PP (1)	■	
20131205	45° bend Ø110 mm	PP (1)	■	
20131208	90° bend Ø110 mm	PP (1)	■	
20131210	Extension Ø110 mm, L=1000 mm	PP (1)	■	
20131218	Ø110 T-junction kit with condensate drain	PP (1)	■	
20131221	Ø110 mm T-junction kit with stack support condensate drain	PP (1)	■	
20131222	Ø110 mm T-junction kit	PP (1)	■	
20131225	Flue cover Ø110 mm with terminal	PP (1)	■	

(\*) PP material: colour may change over time because of sun's rays exposure.







(1) H1 pressure level according to EN 1443.

NOTE: if in the flue line there is a component with P1 pressure level (according to EN 1443), all the line has P1 pressure level even if all the other components are in H1 pressure level (according to EN 1443).

NOTE: please, refer to boiler installation manual for maximum flue line length.

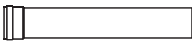
Deductible products only in the context of the refurbishment of the system or the energy-efficient retrofitting of the building. Therefore please always check the specific ways of accessing the incentive.

**Ø110/160 MM CONCENTRIC FLUE GAS EXHAUST SUCTION/DISCHARGE SYSTEM**

CODE	DESCRIPTION	Material (*)	POWER MAX 100 - 150	Description
20131036	45° bend Ø110/160 mm	PP/MET (1)	■	
20131040	90° bend Ø110/160 mm	PP/MET (1)	■	
20131046	Extension Ø110/160 mm, L=500 mm	PP/MET (1)	■	
20131050	Extension Ø110/160 mm, L=1000 mm	PP/MET (1)	■	
20131059	Double adaptor Ø110/110 mm - concentric Ø110/160 mm	PP/MET (1)	■	
20131145	Tile Ø160 mm 25-45% slope	-	■	
20131147	90° bend with inspection Ø110/160 mm	PP/MET (1)	■	
20225183	Outlet on roof Ø110/160 mm	PP/MET (1)	■	

(\*) PP material: colour may change over time because of sun's rays exposure.

(1) H1 pressure level according to EN 1443.







NOTE: if in the flue line there is a component with P1 pressure level (according to EN 1443), all the line has P1 pressure level even if all the other components are in H1 pressure level (according to EN 1443).

NOTE: please, refer to boiler installation manual for maximum flue line length.

Deductible products only in the context of the refurbishment of the system or the energy-efficient retrofitting of the building. Therefore please always check the specific ways of accessing the incentive.



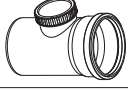
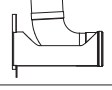

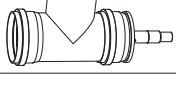





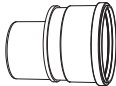

## FLUE OPTION FOR CONDENSING

### PLASTIC FLUE GAS EXHAUST SYSTEM Ø160 MM FOR CONDENSING BOILERS

CODE	DESCRIPTION	Material	IMAGE
20062445	30° bend Ø160 mm	PP	
20032646	45° bend Ø160 mm	PP	
20032644	90° bend Ø160 mm	PP	
20062446	Bend with inspection Ø160 mm	PP	
20060940	Extension Ø160 mm, L=500 mm	PP	
20060941	Extension Ø160 mm, L=1000 mm	PP	
20060942	Extension Ø160 mm, L=2000 mm	PP	
20060945	Stub pipe with inspection Ø160 mm	PP	
20062703	Chimney support Ø160 mm	PP	
20060953	Chimney cover Ø160 mm	PP	
20062447	Condensate drain tube Ø160 mm	PP	
20063419	Inspectable T-shaped chimney support with condensate drain Ø160 mm	PP	
20062448	T-shaped connection with condensate drain Ø160 mm	PP	

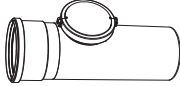
## FLUE OPTION FOR CONDENSING

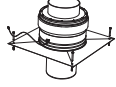
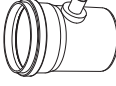
### PLASTIC FLUE GAS EXHAUST SYSTEM Ø200 MM FOR CONDENSING BOILERS

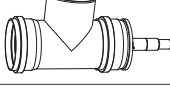



CODE	DESCRIPTION	Material	IMAGE
20062567	Concentric adapter Ø200-160 mm	PP	
20062539	30° bend Ø200 mm	PP	
20062542	45° bend Ø200 mm	PP	
20062543	90° bend Ø200 mm	PP	
20062545	Bend with inspection Ø200 mm	PP	
20062527	Extension Ø200 mm, L=500 mm	PP	
20062530	Extension Ø200 mm, L=1000 mm	PP	
20062532	Extension Ø200 mm, L=2000 mm	PP	
20062534	Extension with inspection Ø200 mm	PP	
20062548	Chimney support Ø200 mm	PP	
20062547	Chimney cover Ø200 mm	PP	
20062537	Condensate drain tube Ø200 mm	PP	
20063420	Inspectable T-shaped chimney support with condensate drain Ø200 mm	PP	
20062550	T-shaped connection with condensate drain Ø200 mm	PP	

**PLASTIC FLUE GAS EXHAUST SYSTEM Ø250 MM FOR CONDENSING BOILERS**

CODE	DESCRIPTION	Material	IMAGE
20062606	Eccentric adapter Ø250-160 mm	PP	
20062607	Concentric adapter Ø250-200 mm	PP	
20132393	Adapter Ø200/Ø250 mm	PP	
20062593	30° bend Ø250 mm	PP	
20062594	45° bend Ø250 mm	PP	
20062595	90° bend Ø250 mm	PP	
20062598	Bend with inspection Ø250 mm	PP	
20062576	Extension Ø250 mm, L=500mm	PP	
20062577	Extension Ø250 mm, L=1000mm	PP	
20062578	Extension Ø250 mm, L=2000mm	PP	
20062591	Extension with inspection Ø250 mm	PP	
20062600	Chimney support Ø250 mm	PP	
20062599	Chimney cover Ø250 mm	PP	
20062592	Condensate drain tube Ø250 mm	PP	
20063421	Inspectable T-shaped chimney support with condensate drain Ø250 mm	PP	
20062601	T-shaped connection with condensate drain Ø250 mm	PP	

## FLUE OPTION FOR CONDENSING

### PLASTIC FLUE GAS EXHAUST SYSTEM Ø300 MM FOR CONDENSING BOILERS

CODE	DESCRIPTION	Material	IMAGE
20158581	Eccentric adapter Ø300-160 mm	PP	
20158580	Eccentric adapter Ø300-250 mm	PP	
20145293	45° bend Ø300 mm	PP	
20145294	90° bend Ø300 mm	PP	
20158567	Bend with inspection Ø300 mm	PP	
20145292	Extension Ø300 mm, L=500 mm	PP	
20145295	Extension Ø300 mm, L=1000 mm	PP	
20145296	Extension Ø300 mm, L=2000 mm	PP	
20145290	Stub pipe with inspection Ø300 mm	PP	
20158569	Chimney support Ø300 mm	PP	
20158566	Condensate drain tube Ø300 mm	PP	
20158572	Inspectable T-shaped chimney support with condensate drain Ø300 mm	PP	
20158571	T-shaped connection with condensate drain Ø300 mm	PP	

**DOUBLE-WALL PLASTIC/STAINLESS STEEL FLUE GAS EXHAUST SYSTEM Ø160-225 MM FOR CONDENSING BOILERS**

CODE	DESCRIPTION	Material	IMAGE
20062658	30° bend Ø160-225 mm	PP/Met	
20062659	45° bend Ø160-225 mm	PP/Met	
20062660	90° bend Ø160-225 mm	PP/Met	
20062655	Extension Ø160-225 mm, L=500 mm	PP/Met	
20062656	Extension Ø160-225 mm, L=1000 mm	PP/Met	
20062657	Extension with inspection Ø160-225 mm, L=1000 mm	PP/Met	
20062662	Tube for terminal Ø160-225 mm	PP/Met	
20062663	Terminal Ø160-225 mm	PP/Met	
20062661	Chimney support Ø160-225 mm	PP/Met	

## FLUE OPTION FOR CONDENSING

### DOUBLE-WALL PLASTIC/STAINLESS STEEL FLUE GAS EXHAUST SYSTEM Ø200-300 MM FOR CONDENSING BOILERS

CODE	DESCRIPTION	Material	IMAGE
20062669	45° bend Ø200-300 mm	PP/Met	
20062670	45° bend Ø200-300 mm	PP/Met	
20062671	90° bend Ø200-300 mm	PP/Met	
20062666	Extension Ø200-300 mm, L=500 mm	PP/Met	
20062667	Extension Ø200-300 mm, L=1000 mm	PP/Met	
20062668	Extension with inspection Ø200-300 mm	PP/Met	
20062673	Tube for terminal Ø200-300 mm	PP/Met	
20062674	Terminal Ø200-300 mm	PP/Met	
20062672	Chimney support Ø200-300 mm	PP/Met	









## FLUE OPTION FOR CONDENSING

### DOUBLE-WALL PLASTIC/STAINLESS STEEL FLUE GAS EXHAUST SYSTEM Ø250-350 MM FOR CONDENSING BOILERS



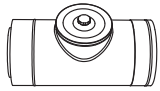
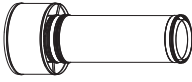

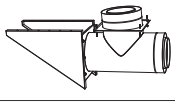

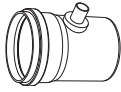



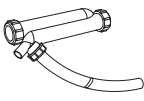

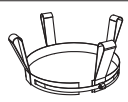

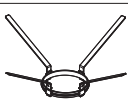
CODE	DESCRIPTION	Material	IMAGE
20062689	45° bend Ø250-350 mm	PP/Met	
20062676	Extension Ø250-350 mm, L=500 mm	PP/Met	
20062677	Extension Ø160-225 mm, L=1000 mm	PP/Met	
20062688	Extension with inspection Ø250-350 mm	PP/Met	
20062691	Tube for terminal Ø250-350 mm	PP/Met	
20062692	Terminal Ø250-350 mm	PP/Met	
20062690	Chimney support Ø250-350 mm	PP/Met	

## FLUE OPTION FOR CONDENSING

### DOUBLE-WALL PLASTIC/STAINLESS STEEL FLUE GAS EXHAUST SYSTEM Ø300-350 MM FOR CONDENSING BOILERS







CODE	DESCRIPTION	Material	IMAGE
20158598	Eccentric adapter Ø300/400-250 mm	PP/Met	
20158600	45° bend Ø300-350 mm	PP/Met	
20158601	Extension Ø300-400 mm, L=500 mm	PP/Met	
20158602	Extension Ø300-400 mm, L=1000 mm	PP/Met	
20158603	Extension with inspection Ø300-400 mm	PP/Met	
20158604	Tube for terminal Ø300-400 mm	PP/Met	
20158605	Terminal Ø300-400 mm	PP/Met	
20158606	Chimney support Ø300-400 mm	PP/Met	
20158607	Boiler start-up kit Ø300/350 mm	PP/Met	
20158594	Tube with condensate drain Ø300-350 mm	PP/Met	

**ACCESSORIES FOR FLUE GAS EXHAUST**

CODE	DESCRIPTION	IMAGE
20062443	Long John trap	
20062510	Tool Ø160 mm	
20062563	Tool Ø200 mm	
20062604	Tool Ø250 mm	
20158577	Spacer Ø300 mm	
20062444	Spacer Ø160 mm	
20060948	Spacer Ø160 mm (5 pcs.)	
20062564	Spacer Ø200 mm	
20062664	Spacer Ø225 mm	
20062605	Spacer Ø250 mm	
20062513	Grille Ø160 mm	
20062575	Grille Ø200 mm	
20062636	Grille Ø250 mm	
20158576	Grille Ø300 mm	
20062512	Rosette Ø160 mm	
20062574	Rosette Ø200 mm	

Flue option systems

## FLUE OPTION FOR CONDENSING

CODE	DESCRIPTION	IMAGE
20062665	Rosette Ø225 mm	
20062635	Rosette Ø250 mm	
20062675	Rosette Ø300 mm	
20062693	Rosette Ø350 mm	
20062449	Bulkhead connector Ø160-225 mm	
20062556	Bulkhead connector Ø200 mm	
20062602	Bulkhead connector Ø250 mm	



AIR CONDITIONING



AIR CONDITIONERS

306



## BREVA E - WALL-HUNG MONO INVERTER AIR CONDITIONERS



- 5.0 kW dualsplit model for cooling and/or heating up to two domestic spaces simultaneously
- Energy efficiency class A++/A+
- R32 refrigerant gas with low environmental impact
- Outdoor unit with high-efficiency dual rotary compressor
- Indoor unit with four-speed fan to achieve high quietness levels, up to 18 dB(A) at superminimum speed
- Simple and elegant aesthetics in glossy white, with concealed display on the indoor units to show the active operating mode, temperature and any alarms
- Infra-red remote control with temperature sensor for enhanced user comfort
- Can be equipped with optional Wi-Fi kit for complete home comfort management even remotely, via dedicated app
- I-FEEL function for temperature adjustment based on that perceived by the remote control
- AUTOMATIC CLEANING and 56°C STERILISATION functions to ensure healthier air coming out of the air conditioner
- QUIET function for ultra-quiet operation at super low fan speed
- COMFORT SLEEP function to optimise comfort during sleeping hours
- MAXIMUM POWER function to quickly reach the desired room conditions

### AIR CONDITIONERS

CODE	MODEL	DIMENSIONS H x W (W1) x D (mm)	HEAT. <sup>(1)</sup> /COOL. <sup>(2)</sup> OUTPUT (kW)	CLASS	
				(D→A <sup>+++</sup> ) <sup>*</sup> SCOP	(D→A <sup>+++</sup> ) <sup>*</sup> SEER
20211075	BREVA 9000-1 E				
<b>CONSISTING OF:</b>					
20206321	BREVA IN 9000 E	290 x 805 x 200	2,80 / 2,60	A <sup>+</sup>	A <sup>++</sup>
20206336	BREVA EX 9000-1 E	544 x 700(777) x 245	-		
20211076	BREVA 12000-1 E				
<b>CONSISTING OF:</b>					
20206322	BREVA IN 12000 E	290 x 805 x 200	3,40 / 3,20	A <sup>+</sup>	A <sup>++</sup>
20206337	BREVA EX 12000-1 E	544 x 700(777) x 245	-		
20211077	BREVA 18000-1 E				
<b>CONSISTING OF:</b>					
20206324	BREVA IN 18000 E	320 x 975 x 220	5,20 / 5,00	A <sup>+</sup>	A <sup>++</sup>
20206338	BREVA EX 18000-1 E	553 x 800(860) x 275	-		

# BREVA E - WALL-HUNG MONO INVERTER AIR CONDITIONERS

CODE	MODEL	DIMENSIONS H x W (W1) x D (mm)	HEAT. <sup>(1)</sup> /COOL. <sup>(2)</sup> OUTPUT (kW)	CLASS	
				(D→A+++)* SCOP	(D→A+++)* SEER
20211078	BREVA 24000-1 E				
<b>CONSISTING OF:</b>					
20206325	BREVA IN 24000 E	320 x 975 x 220	6,80 / 6,80	A+	A++
20206339	BREVA EX 24000-1 E	705 x 890(969) x 340	-		

(\*) The range of energy efficiency class of this products category is between D and A+++  
The efficiency classes are declared in compliance with standard EN 14825, for temperate climate zone and in correspondence of Pdesign -10°C in heating mode and Pdesign 35°C in cooling mode.

Performance refers to the following conditions:

(1) indoor unit air inlet temperature 20°C T d.b., outdoor temperature 7°C d.b., 6°C w.b.

(2) indoor unit air inlet temperature 27°C Td.b., 19°C Tw.b., outdoor temperature 35°C d.b.

For information on possible combinations, refer to the installation manual.

## ACCESSORIES

CODE	DESCRIPTION
20194065	Wi-Fi air conditioner interface

## TECHNICAL DATA

Model	Heating mode yearly consumption kWh/year	Cooling mode yearly consumption kWh/year	Connections liquid mm	Connections gas mm	L/H max <sup>(1)</sup> m
BREVA 9000-1 E	840	149	6,35	9,52	15/10
BREVA 12000-1 E	980	184	6,35	9,52	20/10
BREVA 18000-1 E	1610	287	6,35	12,7	25/15
BREVA 24000-1 E	1960	350	6,35	12,7	25/15

(1) Maximum length with factory charge 5 m for monosplit models 9000-1, 12000-1 and 18000-1. Maximum length with factory charge 7 m for monosplit model 24000-1. Additional charge 20 g/m.

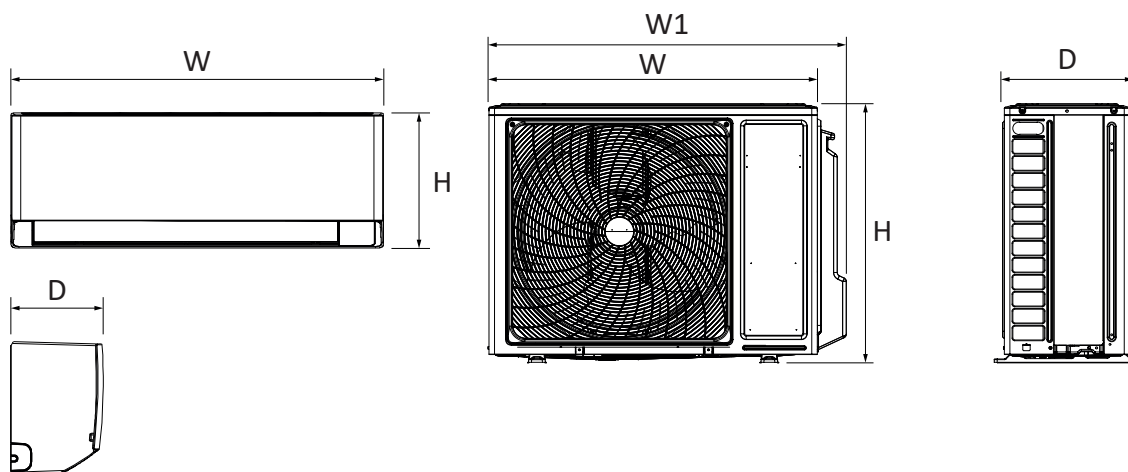

The new codes will be made available for sale once the previous ones are sold out.



Multisplit air conditioners

## BREVA DUAL E - WALL-HUNG MULTI INVERTER AIR CONDITIONERS



- 5.0 kW dualsplit model for cooling and/or heating up to two domestic spaces simultaneously
- Energy efficiency class A++/A+
- R32 refrigerant gas with low environmental impact
- Outdoor unit with high-efficiency dual rotary compressor
- Indoor unit with four-speed fan to achieve high quietness levels, up to 18 dB(A) at superminimum speed
- Simple and elegant aesthetics in glossy white, with concealed display on the indoor units to show the active operating mode, temperature and any alarms
- Infra-red remote control with temperature sensor for enhanced user comfort
- Can be equipped with optional Wi-Fi kit for complete home comfort management even remotely, via dedicated app
- I-FEEL function for temperature adjustment based on that perceived by the remote control
- AUTOMATIC CLEANING and 56°C STERILISATION functions to ensure healthier air coming out of the air conditioner
- QUIET function for ultra-quiet operation at super low fan speed
- COMFORT SLEEP function to optimise comfort during sleeping hours
- MAXIMUM POWER function to quickly reach the desired room conditions

### AIR CONDITIONERS

CODE	MODEL	DIMENSIONS H x W (W1) x D (mm)	HEAT. <sup>(1)</sup> /COOL. <sup>(2)</sup> OUTPUT (kW)	CLASS	
				(D→A <sup>+++</sup> ) <sup>*</sup>	(D→A <sup>+++</sup> ) <sup>*</sup>
				SCOP	SEER
20216942	BREVA 18000-2 (9+9) E				
<b>CONSISTING OF:</b>					
20206321	BREVA IN 9000 E	290 x 805 x 200	4,60 / 4,40	A <sup>+</sup>	A <sup>++</sup>
20206321	BREVA IN 9000 E	290 x 805 x 200			
20206347	BREVA EX 18000-2 E	553 x 800(860) x 275	-	-	-
20216943	BREVA 18000-2 (9+12) E				
<b>CONSISTING OF:</b>					
20206321	BREVA IN 9000 E	290 x 805 x 200	4,60 / 4,40	A <sup>+</sup>	A <sup>++</sup>
20206322	BREVA IN 12000 E	290 x 805 x 200			
20206347	BREVA EX 18000-2 E	553 x 800(860) x 275			

# BREVA DUAL E - WALL-HUNG MULTI INVERTER AIR CONDITIONERS

CODE	MODEL	DIMENSIONS H x W (W1) x D (mm)	HEAT. <sup>(1)</sup> /COOL. <sup>(2)</sup> OUTPUT (kW)	CLASS	
				(D→A <sup>+++</sup> )* SCOP	(D→A <sup>+++</sup> )* SEER
20216944	BREVA 18000-2 (12+12) E				
<b>CONSISTING OF:</b>					
20206322	BREVA IN 12000 E	290 x 805 x 200	4,60 / 4,40	A <sup>+</sup>	A <sup>++</sup>
20206322	BREVA IN 12000 E	290 x 805 x 200			
20206347	BREVA EX 18000-2 E	553 x 800(860) x 275	-	-	-

(\*) The range of energy efficiency class of this products category is between D and A+++  
The efficiency classes are declared in compliance with standard EN 14825, for temperate climate zone and in correspondence of Pdesign -10°C in heating mode and Pdesign 35°C in cooling mode.

Performance refers to the following conditions:

(1) indoor unit air inlet temperature 20°C T d.b., outdoor temperature 7°C d.b., 6°C w.b.

(2) indoor unit air inlet temperature 27°C Td.b., 19°C Tw.b., outdoor temperature 35°C d.b.

The possible combinations are the ones indicated in the table. Combinations other than those indicated are not permitted. It is not allowed to use units with item code not included in the list.

## ACCESSORIES

CODE	DESCRIPTION
20194065	Wi-Fi air conditioner interface

## TECHNICAL DATA

Model	Heating mode yearly consumption kWh/year	Cooling mode yearly consumption kWh/year	Connections liquid mm	Connections gas mm	L/H max <sup>(1)</sup> m
BREVA 18000-2 E	1400	275	2 x 6,35	2 x 9,52	30/15

(1) Maximum length with factory charge 20 m for dual split model 18000-2. Additional charge 20 g/m.

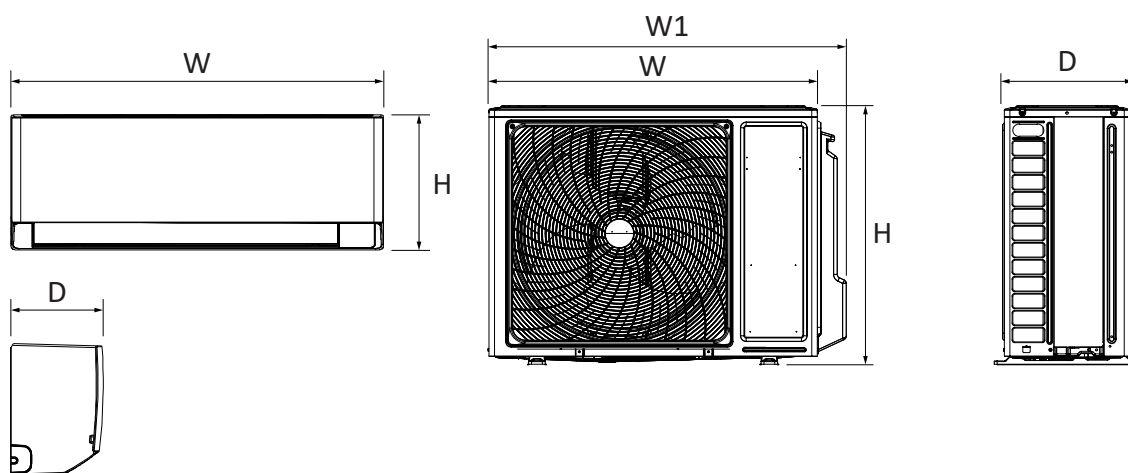



- 5.5 kW three-split models for simultaneous cooling and/or heating of up to three domestic rooms respectively with one outdoor unit
- Energy efficiency class A++/A+
- R32 refrigerant gas with low environmental impact
- Outdoor units with high-efficiency twin rotary compressor
- Indoor units with four-speed fan to achieve high quietness levels, up to 18 dB(A) at superminimum speed
- Simple and elegant aesthetics in glossy white, with display on board the indoor unit to show the active operating mode, temperature and any alarms
- Infra-red remote control with temperature sensor for enhanced user comfort
- Can be equipped with optional Wi-Fi kit for complete home comfort management even remotely, via dedicated app
- I-FEEL function for temperature adjustment based on that perceived by the remote control
- SELF CLEANING and 56°C STERILISATION functions to ensure healthier air coming out of the air conditioner
- QUIET function for ultra-quiet operation at super low fan speed
- COMFORT SLEEP function to optimise comfort during sleeping hours
- MAXIMUM POWER function to quickly reach the desired room conditions

## AIR CONDITIONERS

CODE	MODEL	DIMENSIONS H x W x D (mm)	HEAT. <sup>(1)</sup> /COOL. <sup>(2)</sup> OUTPUT (kW)	CLASS	
				(D→A <sup>+++</sup> ) <sup>*</sup>	(D→A <sup>+++</sup> ) <sup>*</sup>
				SCOP	SEER
20194330	BREVA EX 18.000-3 (outdoor unit)	700 x 890 x 340			
<b>CONSISTING OF:</b>					
20206321	BREVA IN 9000 E	290 x 805 x 200	6,8 / 5,5	A <sup>+</sup>	A <sup>++</sup>
20206321	BREVA IN 9000 E	290 x 805 x 200			
20206321	BREVA IN 9000 E	290 x 805 x 200			
<b>CONSISTING OF:</b>					
20206321	BREVA IN 9000 E	290 x 805 x 200	6,8 / 5,5	A <sup>+</sup>	A <sup>++</sup>
20206321	BREVA IN 9000 E	290 x 805 x 200			
20206322	BREVA IN 12000 E	290 x 805 x 200			

(\*) The range of energy efficiency class of this products category is between D and A+++

The efficiency classes are declared in compliance with standard EN 14825, for temperate climate zone and in correspondence of Pdesign -10°C in heating mode and Pdesign 35°C in cooling mode.

Performance refers to the following conditions:

(1) indoor unit air inlet temperature 20°C T d.b., outdoor temperature 7°C d.b, 6°C w.b.

(2) indoor unit air inlet temperature 27°C Td.b., 19°C Tw.b., outdoor temperature 35°C d.b.

(3) EX means external unit only, IN means internal unit only.

The possible combinations are the ones indicated in the table. Combinations other than those indicated are not permitted. It is not allowed to use units with item code not included in the list.

**BREVA TRIAL - WALL-HUNG MULTI INVERTER AIR CONDITIONERS**

**ACCESSORIES**

CODE	DESCRIPTION
20194065	Wi-Fi air conditioner interface

**TECHNICAL DATA**

Model	Heating mode yearly consumption kWh/year	Cooling mode yearly consumption kWh/year	Connections liquid mm	Connections gas mm	L/H max <sup>(1)</sup> m
BREVA EX 18.000-3	1697	258	3 x 6,35	3 x 9,52	30/15

(1) Maximum length with factory charge 20 m for trial split model 18000-3. Additional charge 20 g/m.

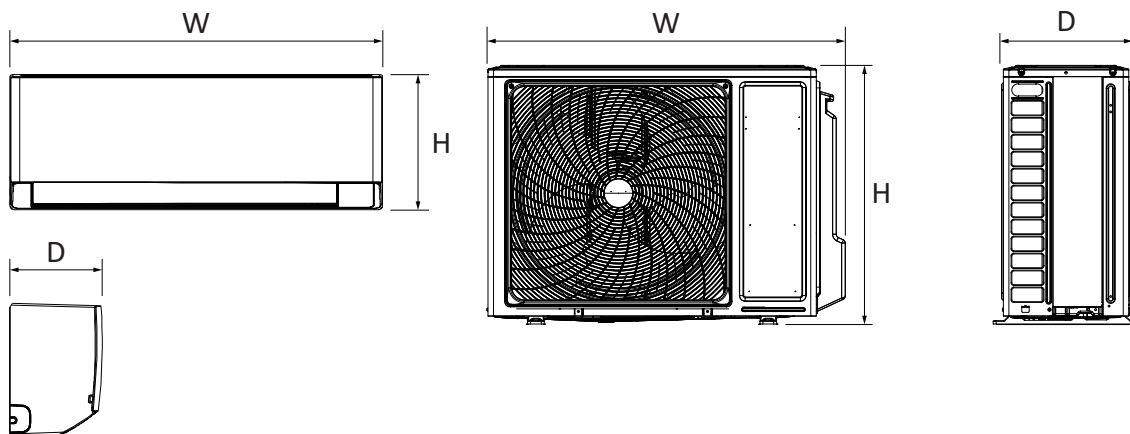



- 7.5 kW four-split models for simultaneous cooling and/or heating of up to four domestic rooms respectively with one outdoor unit
- Energy efficiency class A++/A+
- R32 refrigerant gas with low environmental impact
- Outdoor units with high-efficiency twin rotary compressor
- Indoor units with four-speed fan to achieve high quietness levels, up to 18 dB(A) at superminimum speed
- Simple and elegant aesthetics in glossy white, with display on board the indoor unit to show the active operating mode, temperature and any alarms
- Infra-red remote control with temperature sensor for enhanced user comfort
- Can be equipped with optional Wi-Fi kit for complete home comfort management even remotely, via dedicated app
- I-FEEL function for temperature adjustment based on that perceived by the remote control
- SELF CLEANING and 56°C STERILISATION functions to ensure healthier air coming out of the air conditioner
- QUIET function for ultra-quiet operation at super low fan speed
- COMFORT SLEEP function to optimise comfort during sleeping hours
- MAXIMUM POWER function to quickly reach the desired room conditions

## AIR CONDITIONERS

CODE	MODEL	DIMENSIONS H x W x D (mm)	HEAT. <sup>(1)</sup> /COOL. <sup>(2)</sup> OUTPUT (kW)	CLASS	
				(D→A <sup>+++</sup> ) <sup>*</sup>	(D→A <sup>+++</sup> ) <sup>*</sup>
				SCOP	SEER
20194331	BREVA EX 24.000-4 (outdoor unit)	700 x 890 x 340			
<b>CONSISTING OF:</b>					
20206321	BREVA IN 9000 E	290 x 805 x 200	8,6 /7,5	A <sup>+</sup>	A <sup>++</sup>
20206321	BREVA IN 9000 E	290 x 805 x 200			
20206321	BREVA IN 9000 E	290 x 805 x 200			
20206321	BREVA IN 9000 E	290 x 805 x 200			
<b>CONSISTING OF:</b>					
20206321	BREVA IN 9000 E	290 x 805 x 200	8,6 /7,5	A <sup>+</sup>	A <sup>++</sup>
20206321	BREVA IN 9000 E	290 x 805 x 200			
20206321	BREVA IN 9000 E	290 x 805 x 200			
20206322	BREVA IN 12000 E	290 x 805 x 200			

CODE	MODEL	DIMENSIONS H x W x D (mm)	HEAT. <sup>(1)</sup> /COOL. <sup>(2)</sup> OUTPUT (kW)	CLASS	
				(D→A <sup>+++</sup> ) <sup>*</sup> SCOP	(D→A <sup>+++</sup> ) <sup>*</sup> SEER
<b>CONSISTING OF:</b>					
20206321	BREVA IN 9000 E	290 x 805 x 200	8,6 / 7,5	A <sup>+</sup>	A <sup>++</sup>
20206321	BREVA IN 9000 E	290 x 805 x 200			
20206322	BREVA IN 12000 E	290 x 805 x 200			
20206322	BREVA IN 12000 E	290 x 805 x 200			

(\*) The range of energy efficiency class of this products category is between D and A+++

The efficiency classes are declared in compliance with standard EN 14825, for temperate climate zone and in correspondence of Pdesign -10°C in heating mode and Pdesign 35°C in cooling mode.

Performance refers to the following conditions:

(1) indoor unit air inlet temperature 20°C T d.b., outdoor temperature 7°C d.b., 6°C w.b.

(2) indoor unit air inlet temperature 27°C Td.b., 19°C Tw.b., outdoor temperature 35°C d.b.

(3) EX means external unit only, IN means internal unit only.

The possible combinations are the ones indicated in the table. Combinations other than those indicated are not permitted. It is not allowed to use units with item code not included in the list.

## ACCESSORIES

CODE	DESCRIPTION
20194065	Wi-Fi air conditioner interface

## TECHNICAL DATA

Model	Heating mode yearly consumption kWh/year	Cooling mode yearly consumption kWh/year	Connections liquid mm	Connections gas mm	L/H max <sup>(1)</sup> m
BREVA EX 24.000-4	2179	379	4 x 6,35	3 x 9,52 and 1 x 12,7	40/15

(1) Maximum length with factory charge 20 m for quadri split model 24000-4. Additional charge 20 g/m.

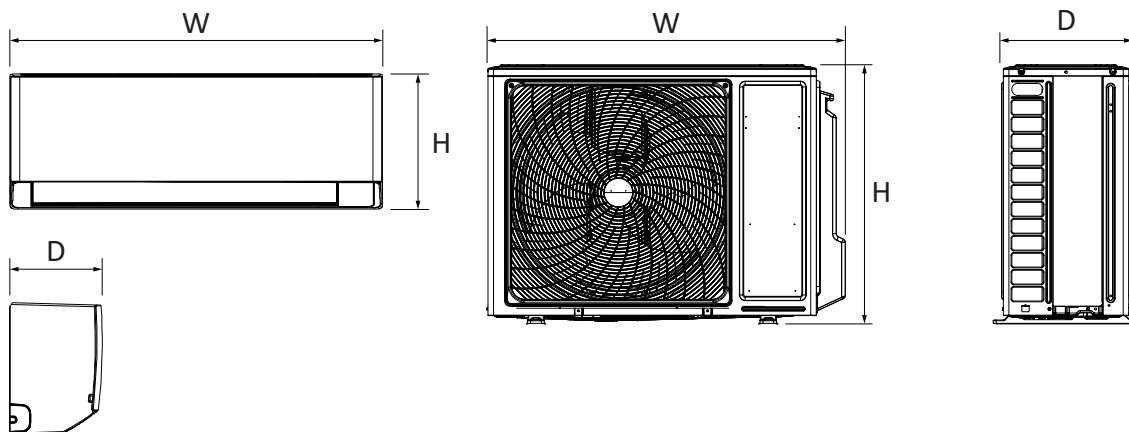

TERMINAL UNITS >>

FAN COILS

316



Wall-mounted fan coils for heating, cooling and dehumidification

## TIVANO WALL



➤➤ Available as standard

- Wall-mounted fan coils for heating / cooling, dehumidification.
- High efficiency DC-Inverter Technology range.
- Three sizes of capacity (heating from 2.78 kW to 5.72 kW; cooling from 1.07 kW to 2.31 kW).
- On-board touch LCD display , unit with temperature display and operation.
- Remote control supplied as standard.
- Fan with DC-inverter Brushless motor.
- Highly silent.
- 2/3-ways valve kits available as option to be installed inside the unit.
- 128 mm depth.
- Motorized wings for a correct air distribution.
- Hydraulic connections to the right.
- White color.

### FAN COILS FOR HEATING, COOLING AND DEHUMIDIFICATION

CODE	DESCRIPTION	DIMENSIONS H x W x D (mm)	HEATING CAPACITY 70°C WATER INLET (kW)	HEATING CAPACITY 45°C WATER INLET (kW)	TOTAL COOLING* CAPACITY (kW)	MAXIMUM AIRFLOW (m³/h)
20186366	TIVANO WALL 27	335 x 902 x 128	2.78	1.27	1.07	228
20186367	TIVANO WALL 41	335 x 1102 x 128	4.12	1.80	1.65	331
20186368	TIVANO WALL 57	335 x 1302 x 128	5.72	2.60	2.31	440

\* Coil inlet water temperature 7°C, coil outlet water temperature 12°C.

### ACCESSORIES FOR TIVANO WALL

CODE	DESCRIPTION
20117090	2-ways manual valve kit
20099250	2-ways motorized valve kit
20099251	3-ways diverter motorized valve kit

TIVANO WALL

INSTALLATION TEMPLATE TIVANO WALL

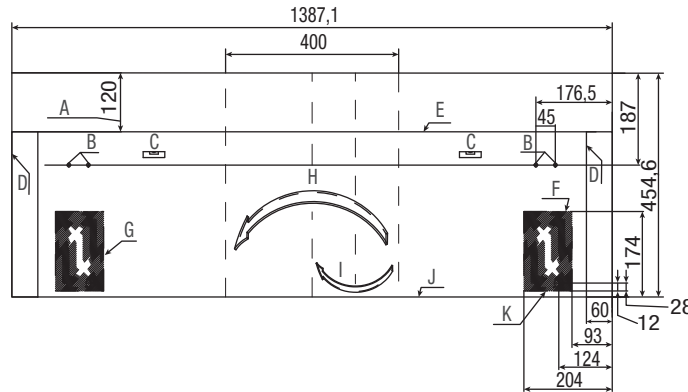

- (A) Minimum distance from the ceiling
- (B) Ø8 mm holes for dowels
- (C) Level for checking alignment
- (D) Outer perimeter for machine with connections on the right
- (E) Upper perimeter of the machine
- (F) Prepare a recessed box for connecting flexible hydraulic pipes for installation on the right
- (G) Electrical connection area for installation on the right
- (H) For the 900 mm long model, bend and join the two dotted lines
- (I) For the 1100 mm long model, bend and join the two dotted lines
- (J) Lower perimeter of the machine
- (K) Condensate drain for hydraulic connections on the right

TECHNICAL DRAWINGS

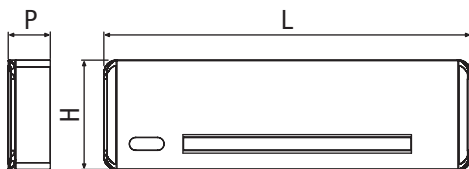

MODEL TIVANO WALL	U.D.M	27	41	57
<b>DIMENSIONS</b>				
H	mm	335	335	335
L	mm	902	1102	1302
P	mm	128	128	128
<b>WEIGHT</b>				
Net weight	kg	14	16	19

MINIMUM CLEARANCE REQUIREMENTS

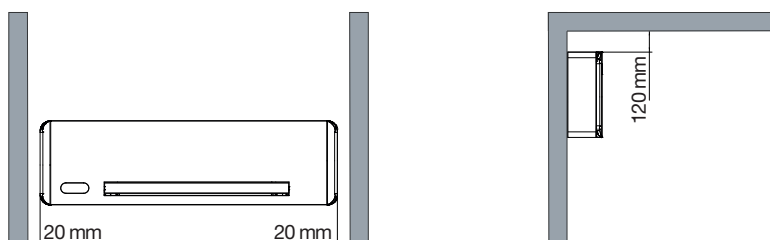

## TIVANO WALL

### TECHNICAL DATA

DESCRIPTION	U.O.M.	TIVANO WALL 27	TIVANO WALL 41	TIVANO WALL 57
<b>Performance</b>				
Total cooling capacity <sup>(a)</sup>	kW	1.07	1.65	2.31
Sensible cooling capacity	kW	0.95	1.49	1.94
Water flow rate	l/h	196	279	402
Water losses	kPa	10.7	4.5	2.1
Heating capacity with 45°C inlet water <sup>(b)</sup>	kW	1.27	1.80	2.60
Water flow rate (45°C water inlet)	l/h	232	351	478
Water losses (45°C water inlet)	kPa	13.9	5.00	4.80
Heating capacity with 70°C water inlet <sup>(c)</sup>	kW	2.78	4.12	5.72
Water flow rate (70°C Δt 10)	l/h	239	354	492
Water losses (70°C Δt 10)	kPa	13	4.7	4.5
<b>Hydraulic features</b>				
Water coil content	litres	0.54	0.74	0.93
Maximum operating pressure	bar	10		
Hydraulic connections	inches	eurokonus 3/4"		
<b>Aeraulic data</b>				
Airflow at maximum ventilation speed	m <sup>3</sup> /h	228	331	440
Airflow at medium speed (AUTO mode)	m <sup>3</sup> /h	155	229	283
Airflow at minimum ventilation speed	m <sup>3</sup> /h	84	124	138
<b>Electrical data</b>				
Power supply	V/ph/Hz	230/1/50		
Maximum power consumption	W	12	14	18
Absorbed power at minimum speed	W	4.8	5.1	5.8
<b>Sound level</b>				
Sound pressure at maximum airflow <sup>(d)</sup>	dB <sup>(A)</sup>	39.7	42.4	42.6
Sound pressure at medium airflow <sup>(d)</sup>	dB <sup>(A)</sup>	24.9	25.2	25.8
<b>general data</b>				
Max - Min temperature (Water inlet)	°C	80 - 4		
Weight	kg	14	16	19

(a) Coil inlet water temperature 7°C, coil outlet water temperature 12°C, air temperature 27°C d.b. and 19°C w.b.

(b) Coil inlet water temperature 45°C, water flow rate as in cooling, air temperature 20°C.

(c) Coil inlet water temperature 70°C, coil outlet water temperature 60°C, air temperature 20°C.

(d) Sound pressure measured in semi-anechoic chamber according to ISO 7779.



- Fan coils and radiant fan coils for heating / cooling, dehumidification and air filtration.
- High efficiency DC-Inverter Technology range.
- Five sizes of capacity (heating from 2.35 kW to 9.36 kW; cooling from 1.06 kW to 4.42 kW).
- Wall-mounted installation (vertical).
- Feet kit available as option for floor-standing installations.
- Highly silent.
- Tangential fan with DC-inverter Brushless motor.
- The fan speed is continuously modulated by the temperature controller.
- 150 mm depth.
- Wide range of complementary accessories.
- White color, flat design.

**FAN COILS WITH DC INVERTER TECHNOLOGY**

CODE	DESCRIPTION	DIMENSIONS H x W x D (mm)	HEATING CAPACITY 70°C WATER INLET (W)	HEATING CAPACITY 50°C WATER INLET (W)	TOTAL COOLING* CAPACITY (W)	MAXIMUM AIRFLOW (m³/h)
20116276	TIVANO 23	580 x 723 x 150	2347	1387	1062	157
20116277	TIVANO 45	580 x 923 x 150	4530	2720	2056	310
20116278	TIVANO 64	580 x 1123 x 150	6436	3827	3211	447
20116279	TIVANO 76	580 x 1323 x 150	7619	4572	3759	559
20116280	TIVANO 94	580 x 1523 x 150	9356	5591	4423	629

\* Coil inlet water temperature 7°C, coil outlet water temperature 12°C.

**ACCESSORIES FOR TIVANO**

CODE	DESCRIPTION
20120559	TIVANO 23 tray kit for ceiling installation
20120560	TIVANO 45 tray kit for ceiling installation
20120562	TIVANO 64 tray kit for ceiling installation

Fan coils and radiant fan coils for heating, cooling and dehumidification

## TIVANO

### FAN COILS WITH FRONT RADIANT PANEL AND WITH DC INVERTER TECHNOLOGY

CODE	DESCRIPTION	DIMENSIONS H x W x D (mm)	HEATING CAPACITY 70°C WATER INLET (W)	HEATING CAPACITY 50°C WATER INLET (W)	TOTAL COOLING* CAPACITY (W)	MAXIMUM AIRFLOW (m <sup>3</sup> /h)
20116281	TIVANO R 23	580 x 723 x 150	2347	1387	1062	157
20116282	TIVANO R 45	580 x 923 x 150	4530	2720	2056	310
20116284	TIVANO R 64	580 x 1123 x 150	6436	3827	3211	447
20116285	TIVANO R 76	580 x 1323 x 150	7619	4572	3759	559

\* Coil inlet water temperature 7°C, coil outlet water temperature 12°C.

Note: For the operation of the fan coils TIVANO and TIVANO R, it is necessary to buy the interface board ALPHA TIVANO REMOTO (code 20116481) to be used with a common three-speed control, or the control ALPHA TIVANO 20 IN (code 20116484) to operate the fan coil 'on board'.

### ACCESSORIES FOR TIVANO AND TIVANO R

CODE	DESCRIPTION
20116481	REMOTE CONTROL INTERFACE - interface board for three-speed control *
20116484	CONTROL PANEL ON BOARD BASIC - control for on board installation with speed selector
20116486	2-way solenoid valve kit (for circulators at variable flow)
20116489	3-way solenoid valve kit for circulators at fixed flow)
20116493	2-way taps kit
20116500	White feet kit
20116503	"L" coupling 90° kit
20116505	Fitting spacer kit

\* Control not included.

TIVANO

TECHNICAL DRAWINGS

DESCRIPTION	U.O.M.	TIVANO 23 / R23	TIVANO 45 / R45	TIVANO 64 / R64	TIVANO 76 / R76	TIVANO 94 / R94
<b>DIMENSIONS</b>						
Width	mm	723	923	1123	1323	1523
Weight						
Net weight	kg	17	20	23	26	29
<b>HYDRAULIC CONNECTIONS - DISTANCE FROM MIDPOINT (X DISTANCE) - IN CASE OF WALL PIPES</b>						
1- Inlet for 3-way diverter valve installation (with spacer connection)	m <sup>3</sup> /h	191	377	543	678	763
2- Inlet for 2-way valve installation (with 90° connection)	m <sup>3</sup> /h	157	310	447	559	629
3- Outlet via 3-way valve	m <sup>3</sup> /h	111	247	360	444	484
4- Outlet via 2-way valve	m <sup>3</sup> /h	54	153	246	366	422
5- Condensate drain	bar	10	10	13	13	13
<b>CLEARANCE</b>						
A	mm	140	140	140	140	140
B	mm	80	80	80 <td 80	80	
C	mm	20	20	20	20	20
D	mm	20	20	20	20	20
E	mm	400	400	400	400	400
F	mm	2500	2500	2500	2500	2500

TIVANO - TIVANO R

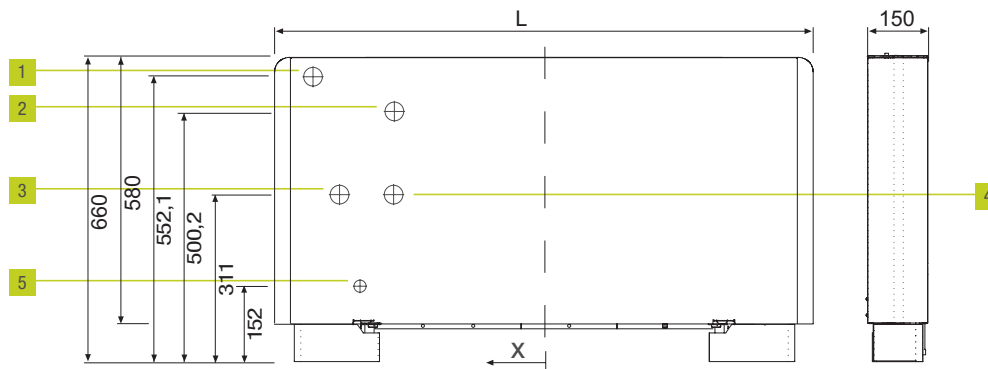

Key:

- (1) Inlet for 3-ways diverter valve installation with spacer connection (using code 20116489 and code 20116505)
- (2) Inlet for 2-ways valve installation with 90° connection (using code 20116486 with code 20116503 or code 20116493 with code 20116503)
- (3) Outlet via 3-ways valve
- (4) Outlet via 2-ways valve
- (5) Condensate drain

WALL-MOUNTED INSTALLATION

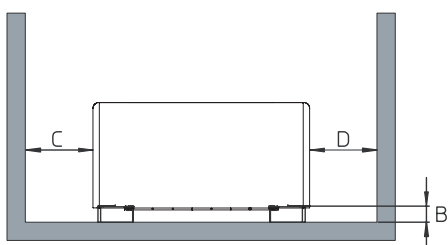

WALL-MOUNTED INSTALLATION

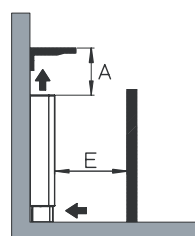

CEILING INSTALLATION

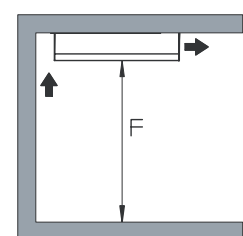

**TECHNICAL DATA**

DESCRIPTION	U.O.M.	TIVANO 23 / R 23	TIVANO 45 / R 45	TIVANO 64 / R 64	TIVANO 76 / R 76	TIVANO 94 / R 94
<b>PERFORMANCE</b>						
Total cooling capacity <sup>(a)</sup>	W	1062	2056	3211	3759	4423
Sensible cooling capacity	W	829	1562	2517	2997	3565
Water flow rate	l/h	183	354	552	647	761
Water losses	kPa	7.6	8.4	23.0	18.3	24.8
Heating capacity with 50°C inlet water <sup>(b)</sup>	W	1387	2720	3827	4572	5591
Water flow rate (50 °C water inlet)	l/h	185	357	558	653	769
Water losses (50 °C water inlet)	kPa	6.3	7.0	17.5	14.5	19.2
Heating capacity with 70°C water inlet <sup>(c)</sup>	W	2347	4530	6436	7619	9356
Water flow rate (70°C Δt 10)	l/h	202	390	553	655	805
Water losses (70°C Δt 10)	kPa	6.9	7.5	16.1	13.5	19.4
Cooling capacity without ventilation (70°C Δt 10)	W	322	379	447	563	690
<b>HYDRAULIC FEATURES</b>						
Water coil content	litres	0.47	0.8	1.13	1.46	1.8
Maximum operating pressure	bar	10	10	10	10	10
Hydraulic connections	inches	eurokonus 3/4				
<b>AERAILIC DATA</b>						
Airflow at "Performance" <sup>(d)</sup>	m <sup>3</sup> /h	191 <sup>(*)</sup>	377 <sup>(*)</sup>	543 <sup>(*)</sup>	678 <sup>(*)</sup>	763 <sup>(*)</sup>
Airflow at medium speed (AUTO mode)	m <sup>3</sup> /h	111 <sup>(*)</sup>	247 <sup>(*)</sup>	360 <sup>(*)</sup>	444 <sup>(*)</sup>	484 <sup>(*)</sup>
Airflow at minimum ventilation speed	m <sup>3</sup> /h	54 <sup>(*)</sup>	153 <sup>(*)</sup>	246 <sup>(*)</sup>	366 <sup>(*)</sup>	422 <sup>(*)</sup>
Maximum static pressure available	Pa	10	10	13	13	13
<b>ELECTRICAL DATA</b>						
Power supply	V/ph/Hz	230/1/50				
Maximum power consumption <sup>(e)</sup>	W	15.1	23.2	26.4	36	40.3
Maximum current input <sup>(e)</sup>	A	0.14	0.21	0.24	0.35	0.38
Absorbed power at minimum speed	W	6	12	14	18	19
<b>Sound level</b>						
Sound pressure at "Performance" <sup>(g)</sup>	dB <sup>(A)</sup>	43.6	44.5	46.9	47.5	48.7
Sound pressure at medium airflow <sup>(g)</sup>	dB <sup>(A)</sup>	34.4	35.3	35.7	36.2	38.9
Sound pressure at minimum airflow <sup>(g)</sup>	dB <sup>(A)</sup>	25.3	26.5	26.6	27.4	28.7
Sound pressure at temperature 'setpoint' <sup>(g)</sup>	dB <sup>(A)</sup>	19.8	20.5	23.3	23.8	24.7

(\*) Cooling Airflow data. Concerning Heating Airflow, it is 20 m<sup>3</sup>/h higher on the model 23 and 40 m<sup>3</sup>/h higher on all other models, at every speed.

(a) Coil inlet water temperature 7°C, coil outlet water temperature 12°C, air temperature 27°C d.b. and 19°C w.b. (UNI EN 1397).

(b) Coil inlet water temperature 50°C, water flow rate as in cooling, air temperature 20°C (UNI EN 1397).

(c) Coil inlet water temperature 70°C, coil outlet water temperature 60°C, air temperature 20°C.

(d) Air flow rate measured with clean filters.

(e) With the maximum number of revolutions.

(g) Sound pressure measured in semi-anechoic chamber according to ISO 7779.



SYSTEM  
COMPLEMENTARY ITEMS



THERMOSTAT AND  
CHRONOTHERMOSTAT

327

HEAT-EXCHANGERS

332

## OVERVIEW OF T300 AND T200 CONFIGURATIONS, T300-HY AND T300-I

			BOILER			HEAT PUMP			IOT
		FULL GAS							✓
T300		FULL ELECTRIC							✓
T200									
		HYBRID							✓
T300-Hy		HYBRID							✓
T300-I		FULL ELECTRIC							✓

(\*) Available only in the Hybrid Systems section with split heat pump



# SMART System - Systems for managing home comfort from Smartphones and Tablets

## HI, COMFORT T300



- Multiple manageable energy sources (gas, electric, hybrid)
- Latest generation APP
- Cooling and heating efficiency



### SMART REMOTE CONTROL HI, COMFORT T300

CODE	MODEL
20205322	Hi, Comfort T300 <sup>(1)(2)(3)(4)</sup>
20134478	Power supply T300 - REC 10H

- (1) Wi-fi as standard.  
 (2) Compatible with heat pumps HYDRO UNIT M.  
 (3) For lengths longer than 30m, add code 20134478.  
 (4) Device provided with gateway.

### SPECIFIC ACCESSORIES

CODE	MODEL	DRAWING
20211852	Environment control Hi, Comfort T200. To be used in combination with a controller via RF communication. Advanced environment sensor, equipped with LCD display, allowing to view and adjust the temperature and the environment set, and the operating mode of the system and the zone it is associated with. Powered by 2 AA batteries. Supplied with plastic support for shelf installation. Class-ErP Contribution: VI-4% <sup>(*)</sup> ; I-1% <sup>(**)</sup> .	

- (\*) With connection via OTBus.  
 (\*\*) In on/off connection.

NOTE:  
 The following versions are also available:  
 Hi, Comfort T300-Hy, only for Bertetta Harmony  
 Hi, Comfort T300-I, only for Tower Green M



## Hi, COMFORT T100 WI-FI



- Control with backlit display to manage your domestic comfort, even remotely with Smartphone and Tablet
- Innovative and easy-to-use app
- Quick commissioning of the app through guided procedure
- Connection to home ADSL Wi-Fi router for Internet access (wi-fi module available)
- Remote control of Beretta boilers in evolved modulating way and of all boilers in ON/OFF
- Modulating chrono-thermostat for evolved control (0.5 °C range) of Beretta boilers
- Universal ON/OFF chrono-thermostat for control of all boilers
- Management of up to 8 independent mixed zones
- Versatile communication: ON/OFF and OTBus wired and wireless
- Cooling mode available
- Room temperature modification from + 3°C to + 35°C with 0,2°C increments
- Weekly time scheduling in 30 minutes intervals (even through APP)
- Direct room temperature reading and internet based external temperature
- Functioning mode: auto, manual, party, holiday, summer
- Three changeable temperature levels: comfort, setback and anti-frost
- Battery status indicator
- Supplied with: batteries 1,5V TIPO AA, bi-adhesive tape, screws, anchors, double-sided tape, wall-mounted plate



### WI-FI REMOTE CONTROLS AND CHRONOTHERMOSTATS

CODE	MODEL	FUNCTIONS	DIMENSIONS H x W x D (mm)	CLASS - CONTRIBUTION ErP
20193354	Hi, Comfort T100 Wi-Fi	Universal Chrono-thermostat ON/OFF <sup>(1)</sup> - Modulating <sup>(2)</sup> - Wi-Fi remote control	89 x 135 x 28	VI-4% <sup>(3)</sup> ; I-1% <sup>(4)</sup>
20193352	Hi, Comfort T100	Universal Chrono-thermostat ON/OFF <sup>(1)</sup> - Modulating <sup>(2)</sup> - Remote control	89 x 135 x 28	V-3% <sup>(3)</sup> ; I-1% <sup>(4)</sup>
20193355	Hi, Comfort G100-W	Gateway for Internet access	83 x 83 x 18	V-3% <sup>(3)</sup> ; I-1% <sup>(4)</sup>
20193356	Hi, Comfort G100-R	Radio receiver to be connected to boiler	83 x 83 x 18	-
20164477	Interface board ITRF11	Interface board to connect Hi, Comfort to Exclusive Boiler Green	-	-

(1) With Hi, Comfort G100-W for internet connection through home ADSL Wi-Fi router.

(2) For wired connection to boiler. Available with radio based connection with Hi, Comfort G100-W cod. 20193355 for internet connection through home ADSL Wi-Fi router.





(3) With boilers Exclusive Boiler Green and Exclusive CAI article number 20164477 "Interface board ITRF11" is required (only when OTBus is implemented).

(4) With BUS connection.

(\*\*) With ON/OFF connection.

## HI, COMFORT T100 WI-FI

### SPECIFIC ACCESSORIES

CODE	DESCRIPTION	DRAWING
20193354	Hi, Comfort T100 Wi-fi Complete KIT for wi-fi installation, containing a room control Hi, Comfort T100 and gateway Hi, Comfort G100-W. Package includes batteries, wires, transformer, screws, anchors, double-sided tape, magnetic tape and technical instructions. Class-ErP grant: VI-4% (*); I-1% (**).	
20193352	Hi, Comfort T100 Room thermostat Hi, Comfort T100 ideal for replacement and new buildings, both for single zone and for multi-zones application. Hi, Comfort T100 can be connected to the internet coupled with Hi, Comfort G100-W (optional). Package includes batteries, screws, anchors, double-sided tape and technical instructions. Class-ErP grant: V-3% (*); I-1% (**).	
20193355	Hi, Comfort G100-W Hi, Comfort G100-W is the device permitting internet connection through domestic Wi-Fi net. It allows as well OT connection with the boiler for remote advanced control. Package includes wires, transformer, double-sided tape.	
20193356	Hi, Comfort G100-R Radio-frequency based device allowing wireless connection of control Hi, Comfort T100 to the boiler (both ON-OFF and through OTBus). It can be used as well when weakness of Wi-Fi signal preclude to install Hi, Comfort G100-W close to the boiler.	
20164477	Board interface ITRF11 Interface Board used to connect Hi, Comfort to boilers Exclusive Boiler Green e Exclusive CAI. To be used only with OTBus connection; For operation in ON/OFF mode it is not required.	

(\*) With BUS connection.

(\*\*) With ON/OFF connection.



Programmable digital room thermostat

## ALPHA 7D / ALPHA 7D WIRELESS



- 7-day programmable room thermostat (in 60-minutes steps).
- Built-in heating programme.
- 3°C ÷ 35°C selectable temperature range with 0.2°C increments.
- 4 modes of operation: auto, advance, off, party.
- 3-temperature selections – comfort, economy, frost.
- Display boiler 'ON'.
- Selectable ON/OFF hysteresis.
- Low battery indicator.
- Summer function for cooling mode (separator relay needed).
- Included in the package: 1.5V batteries (type AAA), screws and wall plugs, double side adhesive.
- Additional features on Alpha 7D Wireless
- Wireless for a flexible installation (pre-cabled).
- 40-metre range.
- Receiver can be mounted to wall (screws and plugs included) or mounted to the side of the boiler (magnetic strips included).

### 7-DAY PROGRAMMABLE ROOM THERMOSTAT

CODE	MODEL	TYPE	DIMENSIONS H x W x D (mm)	CLASS ErP CONTRIBUTION
20063872	ALPHA 7D	7-day digital room-thermostat	86 × 86 × 20	I - 1%
20101748	ALPHA 7D WIRELESS	7-day digital room-thermostat wireless	86 × 86 × 20	I - 1%



Digital room thermostat

## ALPHA DGT / ALPHA DGT WIRELESS



- Digital room thermostat.
- 5°C ÷ 35°C selectable temperature range with 0.2°C increments.
- Easy to read digital display.
- Tactile and easy to rotate selector dial.
- Simple installation.
- Selectable ON/OFF hysteresis.
- Included in the package: 1.5V batteries (type AAA), screws and wall plugs, double side adhesive.
- Additional features on Alpha DGT Wireless
- Wireless for a flexible installation (pre-cabled).
- 40-metre range.
- Receiver can be mounted to wall (screws and plugs included) or mounted to the side of the boiler (magnetic strips included).

### DIGITAL ROOM THERMOSTAT

CODE	MODEL	TYPE	DIMENSIONS H x W x D (mm)	CLASS ErP CONTRIBUTION
20059639	ALPHA DGT	Digital room-thermostat	86 × 86 × 20	I - 1%
20059641	ALPHA DGT WIRELESS	Digital room-thermostat wireless	86 × 86 × 20	I - 1%

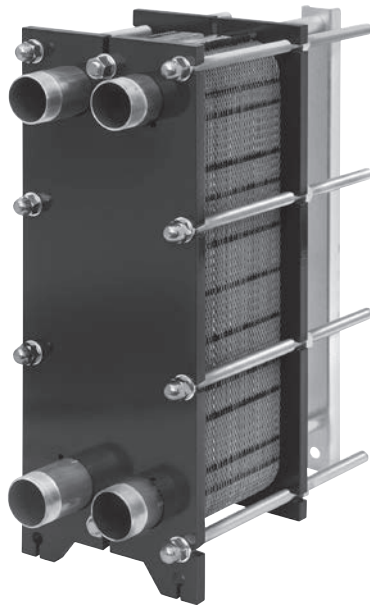
**SP - INSPECTABLE PLATE HEAT EXCHANGER**

- AISI 316L stainless steel gasket plate heat exchangers
- NBR and EPDM gasket versions
- AISI 316L stainless steel thread connections
- Maximum operating temperature: 110 °C
- Maximum operating pressure: 10 bar

**PLATE EXCHANGERS DN 50 - 65 - 100**

CODE	MODEL	No. OF PLATES	DN	MIX %	KIT C	KIT P	WEIGHT KG
<b>HEAT-EXCHANGER AISI 316 L, WITH EPDM PEROXIDE GASKETS</b>							
20200581	SP 20-DN32 29 (29A) E	29	Rp 1" 1/4 (Gas - M)	1	Kit C1	Kit P1	31,3
20200583	SP 20-DN32 41 (41A) E	41	Rp 1" 1/4 (Gas - M)	1	Kit C2	Kit P1	34,7
20200584	SP 30-DN32 17 (17A) E	17	Rp 1" 1/4 (Gas - M)	1	Kit C3	Kit P1	45
20200585	SP 30-DN32 27 (27A) E	27	Rp 1" 1/4 (Gas - M)	1	Kit C3	Kit P1	48,7
20200586	SP 30-DN32 37 (37A) E	37	Rp 1" 1/4 (Gas - M)	1	Kit C4	Kit P1	53,4
20200587	SP 30-DN32 53 (53A) E	53	Rp 1" 1/4 (Gas - M)	1	Kit C5	Kit P1	61,5
20200588	SP 30-DN32 69 (69A) E	69	Rp 1" 1/4 (Gas - M)	1	Kit C5	Kit P1	67,4
20200589	SP 45-DN50 21 (11) E	21	Rp 2" (Gas - M)	0,5	Kit C10	Kit P2	119,7
20200590	SP 45-DN50 29 (15) E	29	Rp 2" (Gas - M)	0,5	Kit C10	Kit P2	125,2
20200591	SP 45-DN50 33 (17) E	33	Rp 2" (Gas - M)	0,5	Kit C10	Kit P2	128
20200592	SP 45-DN50 39 (20) E	39	Rp 2" (Gas - M)	0,5	Kit C10	Kit P2	132,2
20200593	SP 45-DN50 45 (23) E	45	Rp 2" (Gas - M)	0,5	Kit C11	Kit P2	140,6
20200594	SP 45-DN50 51 (26) E	51	Rp 2" (Gas - M)	0,5	Kit C11	Kit P2	144,7
20200595	SP 45-DN50 61 (31) E	61	Rp 2" (Gas - M)	0,5	Kit C11	Kit P2	151,6
20200596	SP 45-DN50 73 (37) E	73	Rp 2" (Gas - M)	0,5	Kit C12	Kit P2	164,2

Plate heat-exchangers

**SP - INSPECTABLE PLATE HEAT EXCHANGER**

CODE	MODEL	No. OF PLATES	DN	MIX %	KIT C	KIT P	WEIGHT KG
20200598	SP 50-DN65 69 (52) E	69	Rp 2" 1/2 (Gas - M)	0,75	Kit C15	Kit P2	217,7
20200599	SP 50-DN65 87 (66) E	87	Rp 2" 1/2 (Gas - M)	0,75	Kit C16	Kit P2	238,1
20200600	SP 50-DN65 101 (76) E	101	Rp 2" 1/2 (Gas - M)	0,75	Kit C16	Kit P2	250,1
20200601	SP 60-DN100 87 (87) E	87	DN100 - PN16	1	Kit C17	Kit P3	375,7
20200602	SP 60-DN100 101 (101) E	101	DN100 - PN16	1	Kit C17	Kit P3	391,7
20200603	SP 60-DN100 115 (115) E	115	DN100 - PN16	1	Kit C18	Kit P3	431,2
20200604	SP 60-DN100 129 (129) E	129	DN100 - PN16	1	Kit C18	Kit P3	447,1

**PLATE HEAT-EXCHANGER AISI 316 L, WITH NBR GASKETS**

20200606	SP 20-DN32 11 (11) N	11	Rp 1" 1/4 (Gas - M)	1	Kit C1	Kit P1	27,1
20200607	SP 20-DN32 21 (21) N	21	Rp 1" 1/4 (Gas - M)	1	Kit C1	Kit P1	29,4
20200608	SP 20-DN32 29 (29) N	29	Rp 1" 1/4 (Gas - M)	1	Kit C1	Kit P1	31,2
20200609	SP 20-DN32 41 (41) N	41	Rp 1" 1/4 (Gas - M)	1	Kit C2	Kit P1	34,8
20200610	SP 20-DN32 49 (49) N	49	Rp 1" 1/4 (Gas - M)	1	Kit C2	Kit P1	36,6
20200611	SP 35-DN50 21 (21) N	21	Rp 2" (Gas - M)	1	Kit C6	Kit P2	79,2
20200613	SP 35-DN50 27 (27) N	27	Rp 2" (Gas - M)	1	Kit C6	Kit P2	81,7
20200614	SP 35-DN50 33 (33) N	33	Rp 2" (Gas - M)	1	Kit C6	Kit P2	84,3
20200615	SP 35-DN50 41 (41) N	41	Rp 2" (Gas - M)	1	Kit C6	Kit P2	87,7
20200616	SP 35-DN50 49 (49) N	49	Rp 2" (Gas - M)	1	Kit C7	Kit P2	94,7
20200618	SP 35-DN50 53 (53) N	53	Rp 2" (Gas - M)	1	Kit C7	Kit P2	96,4
20200619	SP 35-DN50 61 (61) N	61	Rp 2" (Gas - M)	1	Kit C7	Kit P2	99,8
20200620	SP 35-DN50 71 (71) N	71	Rp 2" (Gas - M)	1	Kit C7	Kit P2	104,1
20200621	SP 35-DN50 81 (81) N	81	Rp 2" (Gas - M)	1	Kit C8	Kit P2	111,9
20200622	SP 35-DN50 89 (89) N	89	Rp 2" (Gas - M)	1	Kit C8	Kit P2	115,3
20200623	SP 35-DN50 101 (101) N	101	Rp 2" (Gas - M)	1	Kit C8	Kit P2	120,4
20209452	SP 35-DN50 117 (117) N	117	Rp 2" (Gas - M)	1	Kit C8	Kit P2	124,1
20200624	SP 40-DN65 17 (17) N	17	Rp 2" 1/2 (Gas - M)	1	Kit C13	Kit P2	102,3
20200626	SP 40-DN65 21 (21) N	21	Rp 2" 1/2 (Gas - M)	1	Kit C13	Kit P2	104,7
20200628	SP 40-DN65 25 (25) N	25	Rp 2" 1/2 (Gas - M)	1	Kit C13	Kit P2	107
20200631	SP 40-DN65 33 (33) N	33	Rp 2" 1/2 (Gas - M)	1	Kit C13	Kit P2	111,7
20200633	SP 40-DN65 41 (41) N	41	Rp 2" 1/2 (Gas - M)	1	Kit C13	Kit P2	116,4
20200635	SP 50-DN65 35 (14) N	35	Rp 2" 1/2 (Gas - M)	0,4	Kit C14	Kit P2	183,6
20200637	SP 50-DN65 41 (17) N	41	Rp 2" 1/2 (Gas - M)	0,4	Kit C14	Kit P2	188,7
20200638	SP 50-DN65 45 (18) N	45	Rp 2" 1/2 (Gas - M)	0,4	Kit C15	Kit P2	197,1
20200640	SP 50-DN65 51 (21) N	51	Rp 2" 1/2 (Gas - M)	0,4	Kit C15	Kit P2	202,2
20200642	SP 50-DN65 55 (22) N	55	Rp 2" 1/2 (Gas - M)	0,4	Kit C15	Kit P2	205,7
20200644	SP 50-DN65 61 (25) N	61	Rp 2" 1/2 (Gas - M)	0,4	Kit C15	Kit P2	210,8
20200645	SP 50-DN65 65 (26) N	65	Rp 2" 1/2 (Gas - M)	0,4	Kit C15	Kit P2	214,3
20200646	SP 50-DN65 71 (29) N	71	Rp 2" 1/2 (Gas - M)	0,4	Kit C15	Kit P2	219,4

## SP - INSPECTABLE PLATE HEAT EXCHANGER

CODE	MODEL	No. OF PLATES	DN	MIX %	KIT C	KIT P	WEIGHT KG
20200647	SP 50-DN65 79 (32) N	79	Rp 2" 1/2 (Gas - M)	0,4	Kit C16	Kit P2	231,2
20200648	SP 60-DN100 41 (33) N	41	DN100 - PN16	0,8	Kit C17	Kit P3	323,7
20200658	SP 60-DN100 45 (36) N	45	DN100 - PN16	0,8	Kit C17	Kit P3	328,3
20200659	SP 60-DN100 51 (41) N	51	DN100 - PN16	0,8	Kit C17	Kit P3	335,2
20200663	SP 60-DN100 61 (49) N	61	DN100 - PN16	0,8	Kit C17	Kit P3	346,8
20200665	SP 60-DN100 67 (54) N	67	DN100 - PN16	0,8	Kit C17	Kit P3	353,7
20200667	SP 60-DN100 77 (62) N	77	DN100 - PN16	0,8	Kit C17	Kit P3	365,3
20200670	SP 60-DN100 87 (70) N	87	DN100 - PN16	0,8	Kit C17	Kit P3	376,8
20200672	SP 60-DN100 97 (78) N	97	DN100 - PN16	0,8	Kit C17	Kit P3	388,4
20200673	SP 60-DN100 109 (88) N	109	DN100 - PN16	0,8	Kit C18	Kit P3	425,7
20200674	SP 60-DN100 119 (96) N	119	DN100 - PN16	0,8	Kit C18	Kit P3	437,3
20200675	SP 60-DN100 139 (112) N	139	DN100 - PN16	0,8	Kit C18	Kit P3	460,4
20200676	SP 60-DN100 169 (136) N	169	DN100 - PN16	0,8	Kit C18	Kit P3	495
20200677	SP 60-DN100 201 (161) N	201	DN100 - PN16	0,8	Kit C18	Kit P3	532

Delivery time of the material if not available in stock: up to 30 working days from order validation date.

\*Mix % of high yield plates. - (1) KIT C = insulation kit - (2) KIT P = feet kit

### CONNECTIONS FOR USE WITH POWER MAX THERMAL MODULE

CODE	DESCRIPTION
20132373	Connection kit for plate exchanger (DN80 on 3" collector side /DN50 on plate exchanger side) <sup>(1)</sup>
20203733	Connection kit for plate heat exchanger DN125/DN65
20132376	Connection kit for plate exchanger (DN125 on 5" collector side /DN100 on plate exchanger side) <sup>(1)</sup>

(1) Connection kit with SP exchangers. For selection of the suitable plate exchanger, please contact the pre-sales service

### ACCESSORIES FOR PLATE EXCHANGERS

CODE	MODEL	INSULATION KIT TYPE	MODEL EXCHANGER	No. OF PLATES
20096860	Insulation kit SP 20 29	C1	20	29
20096862	Insulation kit SP 20 49	C2	20	49
20096863	Insulation kit SP 30 29	C3	30	29
20096864	Insulation kit SP 30 49	C4	30	49
20096865	Insulation kit SP 30 75	C5	30	75
20140442	Insulation kit SP 35 41	C6	35	41
20140443	Insulation kit SP 35 71	C7	35	71
20140444	Insulation kit SP 35 101	C8	35	101
20140445	Insulation kit SP 35 151	C9	35	151
20201531	Insulation kit SP 45 41	C10	45	41

## SP - INSPECTABLE PLATE HEAT EXCHANGER

CODE	MODEL	INSULATION KIT TYPE	MODEL EXCHANGER	No. OF PLATES
20201532	Insulation kit SP 45 71	C11	45	71
20201533	Insulation kit SP 45 101	C12	45	101
20201534	Insulation kit SP 40 41	C13	40	41
20201537	Insulation kit SP 50 41	C14	50	41
20201538	Insulation kit SP 50 71	C15	50	71
20201539	Insulation kit SP 50 101	C16	50	101
20096918	Insulation kit SP 60 101	C17	60	101
20116198	Insulation kit SP 60 201	C18	60	201
20120281	P1 feet kit (*)	-	SP 20-30	-
20120282	P2 feet kit (*)	-	SP 35-40	-
20120284	P3 feet kit (*)	-	SP 60	-

Delivery time of the material if not available in stock: up to 30 working days from order validation date.

\*\* Accessories to be ordered only together with the exchanger. - (1) KIT C = insulation kit - (2) KIT P = feet kit

### DIMENSIONS OF SP EXCHANGERS

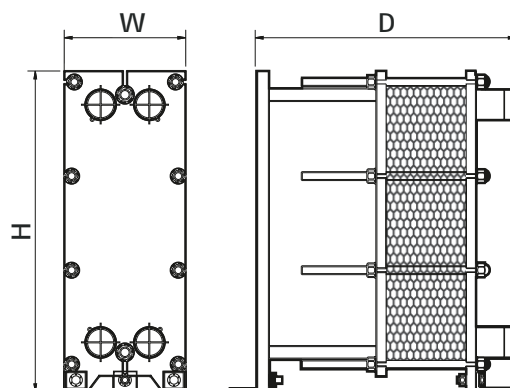

COMMERCIAL NAME	No. OF PLATES from - to	H mm	W mm	D mm
SP 20	11-29	470	200	252
	41-49	470	200	352
SP 30	17-27	755	200	252
	37	755	200	352
	53-69	755	200	552
SP 35	21-41	678	310	408
	49-71	678	310	548
	81-101	678	310	688
SP 40	17-41	729	385	408
SP 45	21-39	1008	310	408
	45-61	1008	310	548
	73	1008	310	688
SP 50	35-41	992	385	408
	45-71	992	385	548
	79-101	992	385	688
SP 60	41-101	1124	509	790
	109-201	1124	509	1290

Plate heat-exchangers

## SP - INSPECTABLE PLATE HEAT EXCHANGER

**MODEL NAME**

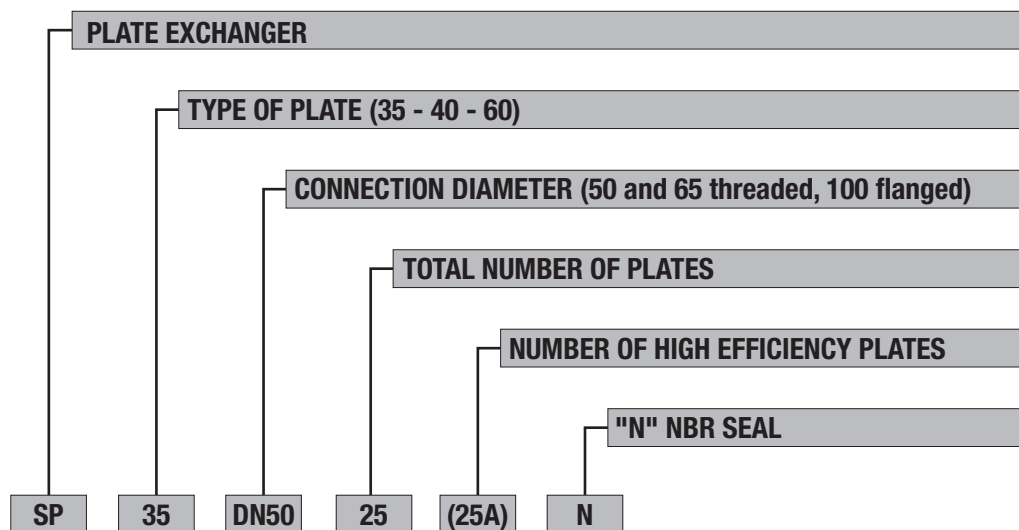

## SP - INSPECTABLE PLATE HEAT EXCHANGER

### PLATE HEAT EXCHANGER COMBINATIONS FOR BOILER OPERATION WITH DIFFERENT $\Delta T$ ML

#### POWER EVO X

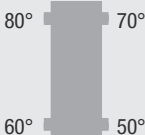
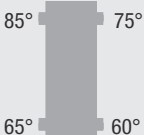
HIGH TEMPERATURE COMBINATIONS			 $\Delta T$ ml= 10 °C $\Delta T$ primary= 20 °C $\Delta T$ secondary= 20 °C T Average secondary circuit = 60 °C			 $\Delta T$ ml= 7,2 °C $\Delta T$ primary= 20 °C $\Delta T$ secondary= 15 °C T Average secondary circuit = 67,5 °C		
NO. OF GENERATORS IN CASCADE	MODEL	DELIVERED OUTPUT [kW]	EXCHANGER	DN	CODE	EXCHANGER	DN	CODE
2	POWER EVO-X 2X 50 DEP	70	SP 35-DN50 21 (21) N	Rp 2" (Gas - M)	20200611	SP 35-DN50 21 (21) N		20200611
	POWER EVO-X 2X 50	90	SP 35-DN50 21 (21) N	Rp 2" (Gas - M)	20200611	SP 35-DN50 27 (27) N	Rp 2" (Gas - M)	20200613
	POWER EVO-X 2x 65	110	SP 35-DN50 21 (21) N	Rp 2" (Gas - M)	20200611	SP 35-DN50 33 (33) N	Rp 2" (Gas - M)	20200614
	POWER EVO-X 2x 80	140	SP 35-DN50 21 (21) N	Rp 2" (Gas - M)	20200611	SP 35-DN50 33 (33) N	Rp 2" (Gas - M)	20200614
3	POWER EVO-X 3x 50 DEP	105	SP 35-DN50 21 (21) N	Rp 2" (Gas - M)	20200611	SP 35-DN50 27 (27) N	Rp 2" (Gas - M)	20200613
	POWER EVO-X 3x 50	140	SP 35-DN50 21 (21) N	Rp 2" (Gas - M)	20200611	SP 35-DN50 33 (33) N	Rp 2" (Gas - M)	20200614
	POWER EVO-X 3x 65	165	SP 35-DN50 27 (27) N	Rp 2" (Gas - M)	20200613	SP 35-DN50 41 (41) N	Rp 2" (Gas - M)	20200615
	POWER EVO-X 3x 80	210	SP 35-DN50 33 (33) N	Rp 2" (Gas - M)	20200614	SP 35-DN50 49 (49) N	Rp 2" (Gas - M)	20200616
4	POWER EVO-X 4x 50 DEP	140	SP 35-DN50 21 (21) N	Rp 2" (Gas - M)	20200611	SP 35-DN50 33 (33) N	Rp 2" (Gas - M)	20200614
	POWER EVO-X 4x 50	180	SP 35-DN50 27 (27) N	Rp 2" (Gas - M)	20200613	SP 35-DN50 41 (41) N	Rp 2" (Gas - M)	20200615
	POWER EVO-X 4x 65	220	SP 35-DN50 33 (33) N	Rp 2" (Gas - M)	20200614	SP 35-DN50 53 (53) N	Rp 2" (Gas - M)	20200618
	POWER EVO-X 4x 80	280	SP 35-DN50 41 (41) N	Rp 2" (Gas - M)	20200615	SP 35-DN50 61 (61) N	Rp 2" (Gas - M)	20200619

#### POWER MAX

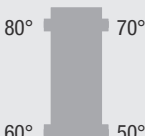
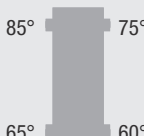
HIGH TEMPERATURE COMBINATIONS			 $\Delta T$ ml= 10 °C $\Delta T$ primary= 20 °C $\Delta T$ secondary= 20 °C T Average secondary circuit = 60 °C			 $\Delta T$ ml= 7,2 °C $\Delta T$ primary= 20 °C $\Delta T$ secondary= 15 °C T Average secondary circuit = 67,5 °C		
NO. OF GENERATORS IN CASCADE	MODEL	DELIVERED OUTPUT [kW]	EXCHANGER	DN	CODE	EXCHANGER	DN	CODE
2	Power Max 2x 65 P	114	SP 35-DN50 21 (21) N	Rp 2" (G-M)*	20200611	SP 35-DN50 33 (33) N	Rp 2" (G-M)*	20200614
	Power Max 2x 80 P	136	SP 35-DN50 21 (21) N	Rp 2" (G-M)*	20200611	SP 35-DN50 33 (33) N	Rp 2" (G-M)*	20200614
	Power Max 2x 100	180	SP 35-DN50 27 (27) N	Rp 2" (G-M)*	20200613	SP 35-DN50 49 (49) N	Rp 2" (G-M)*	20200616
	Power Max 2x 110	194	SP 35-DN50 33 (33) N	Rp 2" (G-M)*	20200614	SP 35-DN50 49 (49) N	Rp 2" (G-M)*	20200616
	Power Max 2x 130 (115 Hi)	224	SP 35-DN50 33 (33) N	Rp 2" (G-M)*	20200614	SP 35-DN50 53 (53) N	Rp 2" (G-M)*	20200618
	Power Max 2x 150	262	SP 35-DN50 41 (41) N	Rp 2" (G-M)*	20200615	SP 35-DN50 61 (61) N	Rp 2" (G-M)*	20200619

## SP - INSPECTABLE PLATE HEAT EXCHANGER

HIGH TEMPERATURE COMBINATIONS			 $\Delta T_{ml} = 10\text{ }^{\circ}\text{C}$ $\Delta T_{\text{primary}} = 20\text{ }^{\circ}\text{C}$ $\Delta T_{\text{secondary}} = 20\text{ }^{\circ}\text{C}$ $T_{\text{Average secondary circuit}} = 60\text{ }^{\circ}\text{C}$			 $\Delta T_{ml} = 7,2\text{ }^{\circ}\text{C}$ $\Delta T_{\text{primary}} = 20\text{ }^{\circ}\text{C}$ $\Delta T_{\text{secondary}} = 15\text{ }^{\circ}\text{C}$ $T_{\text{Average secondary circuit}} = 67,5\text{ }^{\circ}\text{C}$		
NO. OF GENERATORS IN CASCADE	MODEL	DELIVERED OUTPUT [kW]	EXCHANGER	DN	CODE	EXCHANGER	DN	CODE
3	Power Max 3x 65 P	171	SP 35-DN50 27 (27) N	Rp 2" (G-M)*	20200613	SP 35-DN50 41 (41) N	Rp 2" (G-M)*	20200615
	Power Max 3x 80 P	204	SP 35-DN50 33 (33) N	Rp 2" (G-M)*	20200614	SP 35-DN50 49 (49) N	Rp 2" (G-M)*	20200616
	Power Max 3x 100	270	SP 35-DN50 41 (41) N	Rp 2" (G-M)*	20200615	SP 35-DN50 61 (61) N	Rp 2" (G-M)*	20200619
	Power Max 3x 110	291	SP 35-DN50 41 (41) N	Rp 2" (G-M)*	20200615	SP 35-DN50 71 (71) N	Rp 2" (G-M)*	20200620
	Power Max 3x 130 (115 Hi)	336	SP 35-DN50 49 (49) N	Rp 2" (G-M)*	20200616	SP 35-DN50 81 (81) N	Rp 2" (G-M)*	20200621
	Power Max 3x 150	393	SP 35-DN50 61 (61) N	Rp 2" (G-M)*	20200619	SP 35-DN50 89 (89) N	Rp 2" (G-M)*	20200622
4	Power Max 4x 65 P	228	SP 35-DN50 33 (33) N	Rp 2" (G-M)*	20200614	SP 35-DN50 53 (53) N	Rp 2" (G-M)*	20200618
	Power Max 4x 80 P	272	SP 35-DN50 41 (41) N	Rp 2" (G-M)*	20200615	SP 35-DN50 61 (61) N	Rp 2" (G-M)*	20200619
	Power Max 4x 100	360	SP 35-DN50 49 (49) N	Rp 2" (G-M)*	20200616	SP 35-DN50 81 (81) N	Rp 2" (G-M)*	20200621
	Power Max 4x 110	388	SP 35-DN50 53 (53) N	Rp 2" (G-M)*	20200618	SP 35-DN50 89 (89) N	Rp 2" (G-M)*	20200622
	Power Max 4x 130 (115 Hi)	448	SP 35-DN50 61 (61) N	Rp 2" (G-M)*	20200619	SP 35-DN50 101 (101) N	Rp 2" (G-M)*	20200623
	Power Max 4x 150	524	SP 50-DN65 35 (14) N	Rp 2" 1/2 (G -M)*	20200635	SP 50-DN65 55 (22) N	Rp 2" 1/2 (G-M)*	20200642
5	Power Max 5x 65 P	285	SP 35-DN50 41 (41) N	Rp 2" (G-M)*	20200615	SP 35-DN50 71 (71) N	Rp 2" (G-M)*	20200620
	Power Max 5x 80 P	340	SP 35-DN50 49 (49) N	Rp 2" (G-M)*	20200616	SP 35-DN50 81 (81) N	Rp 2" (G-M)*	20200621
	Power Max 5x 100	450	SP 35-DN50 61 (61) N	Rp 2" (G-M)*	20200619	SP 35-DN50 101 (101) N	Rp 2" (G-M)*	20200623
	Power Max 5x 110	485	SP 35-DN50 71 (71) N	Rp 2" (G-M)*	20200620	SP 35-DN50 101 (101) N	Rp 2" (G-M)*	20200623
	Power Max 5x 130 (115 Hi)	560	SP 50-DN65 41 (17) N	Rp 2" (G-M)*	20200637	SP 50-DN65 55 (22) N	Rp 2" 1/2 (G-M)*	20200642
	Power Max 5x 150	655	SP 50-DN65 45 (18) N	Rp 2" (G-M)*	20200638	SP 50-DN65 65 (26) N	Rp 2" 1/2 (G-M)*	20200645
6	Power Max 6x 65 P	342	SP 35-DN50 49 (49) N	Rp 2" (G-M)*	20200616	SP 35-DN50 81 (81) N	Rp 2" (G-M)*	20200621
	Power Max 6x 80 P	408	SP 35-DN50 61 (61) N	Rp 2" (G-M)*	20200619	SP 35-DN50 89 (89) N	Rp 2" (G-M)*	20200622
	Power Max 6x 100	540	SP 50-DN65 35 (14) N	Rp 2" 1/2 (G -M)*	20200635	SP 50-DN65 55 (22) N	Rp 2" 1/2 (G-M)*	20200642
	Power Max 6x 110	582	SP 50-DN65 41 (17) N	Rp 2" 1/2 (G -M)*	20200637	SP 50-DN65 61 (25) N	Rp 2" 1/2 (G-M)*	20200644
	Power Max 6x 130 (115 Hi)	672	SP 50-DN65 45 (18) N	Rp 2" 1/2 (G -M)*	20200638	SP 50-DN65 65 (26) N	Rp 2" 1/2 (G-M)*	20200645
	Power Max 6x 150	786	SP 50-DN65 51 (21) N	Rp 2" 1/2 (G -M)*	20200640	SP 50-DN65 79 (32) N	Rp 2" 1/2 (G-M)*	20200647
7	Power Max 7x 65 P	399	SP 35-DN50 53 (53) N	Rp 2" (G-M)*	20200618	SP 35-DN50 89 (89) N	Rp 2" (G-M)*	20200622
	Power Max 7x 80 P	476	SP 35-DN50 71 (71) N	Rp 2" (G-M)*	20200620	SP 35-DN50 101 (101) N	Rp 2" (G-M)*	20200623
	Power Max 7x 100	630	SP 50-DN65 41 (17) N	Rp 2" 1/2 (G -M)*	20200637	SP 50-DN65 65 (26) N	Rp 2" 1/2 (G-M)*	20200645
	Power Max 7x 110	679	SP 50-DN65 45 (18) N	Rp 2" 1/2 (G -M)*	20200638	SP 50-DN65 71 (29) N	Rp 2" 1/2 (G-M)*	20200646
	Power Max 7x 130 (115 Hi)	784	SP 50-DN65 51 (21) N	Rp 2" 1/2 (G -M)*	20200640	SP 50-DN65 79 (32) N	Rp 2" 1/2 (G-M)*	20200647
	Power Max 7x 150	917	SP 60-DN100 45 (36) N	DN100 - PN16	20200658	SP 60-DN100 67 (54) N	DN100 - PN16	20200665

## SP - INSPECTABLE PLATE HEAT EXCHANGER

HIGH TEMPERATURE COMBINATIONS								
NO. OF GENERATORS IN CASCADE	MODEL	DELIVERED OUTPUT [kW]	EXCHANGER	DN	CODE	EXCHANGER	DN	CODE
8	Power Max 8x 65 P	456	SP 35-DN50 61 (61) N	Rp 2" (G-M)*	20200619	SP 35-DN50 101 (101) N	Rp 2" (G-M)*	20200623
	Power Max 8x 80 P	544	SP 50-DN65 35 (14) N	Rp 2" 1/2 (G-M)*	20200635	SP 50-DN65 55 (22) N	Rp 2" 1/2 (G-M)*	20200642
	Power Max 8x 100	720	SP 50-DN65 51 (21) N	Rp 2" 1/2 (G-M)*	20200640	SP 50-DN65 71 (29) N	Rp 2" 1/2 (G-M)*	20200646
	Power Max 8x 110	776	SP 50-DN65 55 (22) N	Rp 2" 1/2 (G-M)*	20200642	SP 50-DN65 79 (32) N	Rp 2" 1/2 (G-M)*	20200647
	Power Max 8x 130 (115 Hi)	896	SP 60-DN100 45 (36) N	DN100 - PN16	20200658	SP 60-DN100 67 (54) N	DN100 - PN16	20200665
	Power Max 8x 150	1048	SP 60-DN100 51 (41) N	DN100 - PN16	20200659	SP 60-DN100 77 (62) N	DN100 - PN16	20200667
9	Power Max 9x 65 P	513	SP 50-DN65 35 (14) N	Rp 2" 1/2 (G-M)*	20200635	SP 50-DN65 51 (21) N	Rp 2" 1/2 (G-M)*	20200640
	Power Max 9x 80 P	612	SP 50-DN65 41 (17) N	Rp 2" 1/2 (G-M)*	20200637	SP 50-DN65 61 (25) N	Rp 2" 1/2 (G-M)*	20200644
	Power Max 9x 100	810	SP 60-DN100 41 (33) N	DN100 - PN16	20200648	SP 60-DN100 61 (49) N	DN100 - PN16	20200663
	Power Max 9x 110	873	SP 60-DN100 45 (36) N	DN100 - PN16	20200658	SP 60-DN100 67 (54) N	DN100 - PN16	20200665
	Power Max 9x 130 (115 Hi)	1008	SP 60-DN100 51 (41) N	DN100 - PN16	20200659	SP 60-DN100 77 (62) N	DN100 - PN16	20200667
10	Power Max 10x 65 P	570	SP 50-DN65 41 (17) N	Rp 2" 1/2 (G-M)*	20200637	SP 50-DN65 61 (25) N	Rp 2" 1/2 (G-M)*	20200644
	Power Max 10x 80 P	680	SP 50-DN65 45 (18) N	Rp 2" 1/2 (G-M)*	20200638	SP 50-DN65 71 (29) N	Rp 2" 1/2 (G-M)*	20200646
	Power Max 10x 100	900	SP 60-DN100 45 (36) N	DN100 - PN16	20200658	SP 60-DN100 67 (54) N	DN100 - PN16	20200665
	Power Max 10x 110	970	SP 60-DN100 51 (41) N	DN100 - PN16	20200659	SP 60-DN100 77 (62) N	DN100 - PN16	20200667
	Power Max 10x 130 (115 Hi)	1120	SP 60-DN100 61 (49) N	DN100 - PN16	20200663	SP 60-DN100 87 (70) N	DN100 - PN16	20200670

(\*) G-M: Gas - M

## SP - INSPECTABLE PLATE HEAT EXCHANGER

### POWER MAX BOX

HIGH TEMPERATURE COMBINATIONS			 $\Delta T_{ml} = 10\text{ °C}$ $\Delta T_{\text{primary}} = 20\text{ °C}$ $\Delta T_{\text{secondary}} = 20\text{ °C}$ $T_{\text{Average secondary circuit}} = 60\text{ °C}$			 $\Delta T_{ml} = 7,2\text{ °C}$ $\Delta T_{\text{primary}} = 20\text{ °C}$ $\Delta T_{\text{secondary}} = 15\text{ °C}$ $T_{\text{Average secondary circuit}} = 67,5\text{ °C}$		
NO. OF GENERATORS IN CASCADE	MODEL	DELIVERED OUTPUT [kW]	EXCHANGER	DN	CODE	EXCHANGER	DN	CODE
1	POWER MAX BOX 130-2 P	114	SP 35-DN50 21 (21) N	Rp 2" (G-M)*	20200611	SP 35-DN50 33 (33) N	Rp 2" (G-M)*	20200614
	POWER MAX BOX 160-2 P	136	SP 35-DN50 21 (21) N	Rp 2" (G-M)*	20200611	SP 35-DN50 33 (33) N	Rp 2" (G-M)*	20200614
	POWER MAX BOX 200-2 P	180	SP 35-DN50 27 (27) N	Rp 2" (G-M)*	20200613	SP 35-DN50 49 (49) N	Rp 2" (G-M)*	20200616
	POWER MAX BOX 260-2 P	224	SP 35-DN50 33 (33) N	Rp 2" (G-M)*	20200614	SP 35-DN50 53 (53) N	Rp 2" (G-M)*	20200618
	POWER MAX BOX 300-2 P	262	SP 35-DN50 41 (41) N	Rp 2" (G-M)*	20200615	SP 35-DN50 61 (61) N	Rp 2" (G-M)*	20200619
	POWER MAX BOX 330-3 P	291	SP 35-DN50 41 (41) N	Rp 2" (G-M)*	20200615	SP 35-DN50 71 (71) N	Rp 2" (G-M)*	20200620
	POWER MAX BOX 390-3 P	336	SP 35-DN50 49 (49) N	Rp 2" (G-M)*	20200616	SP 35-DN50 81 (81) N	Rp 2" (G-M)*	20200621
	POWER MAX BOX 450-3 P	393	SP 35-DN50 61 (61) N	Rp 2" (G-M)*	20200619	SP 35-DN50 89 (89) N	Rp 2" (G-M)*	20200622
	POWER MAX BOX 520-4 P	448	SP 35-DN50 61 (61) N	Rp 2" (G-M)*	20200619	SP 35-DN50 101 (101) N	Rp 2" (G-M)*	20200623
	POWER MAX BOX 600-4 P	524	SP 50-DN65 35 (14) N	Rp 2" 1/2 (G-M)*	20200635	SP 50-DN65 55 (22) N	Rp 2" 1/2 (G-M)*	20200642
2	POWER MAX BOX 750	655	SP 50-DN65 45 (18) N	Rp 2" 1/2 (G-M)*	20200638	SP 50-DN65 65 (26) N	Rp 2" 1/2 (G-M)*	20200645
	POWER MAX BOX 900	786	SP 50-DN65 51 (21) N	Rp 2" 1/2 (G-M)*	20200640	SP 50-DN65 79 (32) N	Rp 2" 1/2 (G-M)*	20200647
	POWER MAX BOX 1050	917	SP 60-DN100 45 (36) N	DN100 - PN16	20200658	SP 60-DN100 67 (54) N	DN100 - PN16	20200665
	POWER MAX BOX 1200	1048	SP 60-DN100 51 (41) N	DN100 - PN16	20200659	SP 60-DN100 77 (62) N	DN100 - PN16	20200667
3	POWER MAX BOX 1350	1179	SP 60-DN100 61 (49) N	DN100 - PN16	20200663	SP 60-DN100 87 (70) N	DN100 - PN16	20200670
	POWER MAX BOX 1500	1310	SP 60-DN100 67 (54) N	DN100 - PN16	20200665	SP 60-DN100 97 (78) N	DN100 - PN16	20200672

(\*) G-M: Gas - M

## POWER MAX BOX

Plate heat exchanger combinations for boiler operation with a mixture of water and glycol (max 40%)\*

HIGH TEMPERATURE COMBINATIONS			<p> <math>\Delta T_{ml} = 7,2\text{ }^{\circ}\text{C}</math>  <math>\Delta T_{\text{primary}} = 20\text{ }^{\circ}\text{C}</math>  <math>\Delta T_{\text{secondary}} = 15\text{ }^{\circ}\text{C}</math>  <math>T_{\text{Average secondary circuit}} = 67,5\text{ }^{\circ}\text{C}</math> </p>		
NO. OF GENERATORS IN CASCADE	MODEL	DELIVERED OUTPUT [kW]	EXCHANGER	DN	CODE
1	POWER MAX BOX 130-2 P	114	SP 45-DN50 21 (11) E	Rp 2" (G-M)*	20200589
	POWER MAX BOX 160-2 P	136	SP 45-DN50 29 (15) E	Rp 2" (G-M)*	20200590
	POWER MAX BOX 200-2 P	180	SP 45-DN50 29 (15) E	Rp 2" (G-M)*	20200590
	POWER MAX BOX 260-2 P	224	SP 45-DN50 33 (17) E	Rp 2" (G-M)*	20200591
	POWER MAX BOX 300-2 P	262	SP 45-DN50 39 (20) E	Rp 2" (G-M)*	20200592
	POWER MAX BOX 330-3 P	291	SP 45-DN50 45 (23) E	Rp 2" (G-M)*	20200593
	POWER MAX BOX 390-3 P	336	SP 45-DN50 51 (26) E	Rp 2" (G-M)*	20200594
	POWER MAX BOX 450-3 P	393	SP 45-DN50 61 (31) E	Rp 2" (G-M)*	20200595
	POWER MAX BOX 520-4 P	448	SP 45-DN50 73 (37) E	Rp 2" (G-M)*	20200596
	POWER MAX BOX 600-4 P	524	SP 50-DN65 69 (52) E	Rp 2" 1/2 (G-M)*	20200598
2	POWER MAX BOX 750	655	SP 50-DN65 87 (66) E	Rp 2" 1/2 (G-M)*	20200599
	POWER MAX BOX 900	786	SP 50-DN65 101 (76) E	Rp 2" 1/2 (G-M)*	20200600
	POWER MAX BOX 1050	917	SP 60-DN100 87 (87) E	DN100 - PN16	20200601
	POWER MAX BOX 1200	1048	SP 60-DN100 101 (101) E	DN100 - PN16	20200602
3	POWER MAX BOX 1350	1179	SP 60-DN100 115 (115) E	DN100 - PN16	20200603
	POWER MAX BOX 1500	1310	SP 60-DN100 129 (129) E	DN100 - PN16	20200604

(\* Not compatible with containment cabinets.

In case the POWER MAX BOX will be installed OUTDOOR, the GPHE must be installed INDOOR near the Horizontal Flow & Return distribution manifolds.

## PALLET CONFIGURATION AND KEY

### WALL-HUNG CONDENSING BOILERS

EXCLUSIVE EVO X	6-piece pallet
MYNUTE EVO X	6-piece pallet
MYNUTE BOILER EVO X	6-piece pallet
CIAO X	6-piece pallet
BLR	6-piece pallet

### CONDENSING BOILER BASE

TOWER GREEN HE HYBRID	1-piece pallet
TOWER GREEN HE S	1-piece pallet
TOWER GREEN HE	1-piece pallet
TOWER GREEN COMPACT	1-piece pallet

### STANDARD WALL-HUNG BOILERS

METEO C.A.I. LX	6-piece pallet
MYNUTE C.A.I. LX	6-piece pallet
CIAO C.A.I. LX	6-piece pallet

### WATER HEATERS / DHW HEAT PUMPS

ACQUAZENIT	1-piece pallet
IDRABAGNO 11 - 13	12-piece pallet
IDRABAGNO 17	6-piece pallet
IDRABALCONY	6-piece pallet
FORTE LX P	12-piece pallet

### TYPE OF GAS

MTN	Methane
GPL	Liquid gas

### WALL-HUNG BOILER AND BASE

R.A.I.	Heating open ionised
R.S.I.	Heating condensing
R	Heating condensing
C.A.I.	Combi open ionised
C.S.I.	Combi condensing
C	Combi condensing
B.A.I.	Storage cylinder open ionised
B.S.I.	Storage cylinder condensing
AG	Anti-freeze kit as standard
HE	High-efficiency
X	Stainless steel heat exchanger

### WATER HEATERS

FORTE	Open ionised coil
IDRABAGNO	Watertight ionised

CERTIFIED BOILERS AND WATER HEATERS



NOTES: These technical data are approximate; for the true values, refer to the technical datasheets.









RIELLO S.p.A.  
Via Ing. Pilade Riello, 7  
37045 Legnago (VR) – Italia  
tel. +39 0442 630111

[www.berettaheating.com](http://www.berettaheating.com)

