

POWER MAX SYSTEM

Condensation | Module

EN Installation Manual

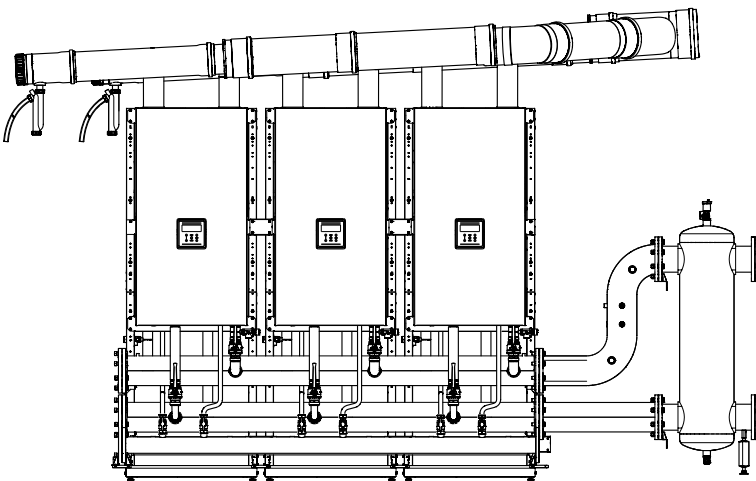

CONTENTS

1	GENERAL INFORMATION	3	4	SYSTEM MANAGEMENT	67
1.1	General Safety Information	3	4.1	Module addressing via dip switches	67
1.2	Description of the appliance	3	4.2	Bus connections	68
1.3	System layout	4	4.3	Connection to External Zone controller	68
1.3.1	In line lay-out (FRONT) with 2 modules	4	4.4	Removing external zone	69
1.3.2	In line lay-out (FRONT) with 3 modules	5	4.5	Configuration of Dependent zones	69
1.3.3	In line lay-out (FRONT) with 4 modules	6	4.5.1	Deleting dependent zone	70
1.3.4	In line lay-out (FRONT) with 5 modules	7			
1.3.5	In line lay-out (FRONT) with 6 modules	8	5	COMMISSIONING AND MAINTENANCE ...	71
1.3.6	In line lay-out (FRONT) with 7 modules	9	5.1	Repositioning the front panels	71
1.3.7	In line lay-out (FRONT) with 8 modules	10	5.2	Putting the system into service	71
1.3.8	In line lay-out (FRONT) with 9 modules	11	5.3	Electronic control	72
1.3.9	In line lay-out (FRONT) with 10 modules	12	5.3.1	USER navigation MENU	72
1.3.10	B2B (BACK TO BACK) layout with 2 modules ..	13	5.3.2	Navigation Menu INSTALLER /	
1.3.11	B2B (BACK TO BACK) layout with 3 and 4			MANUFACTURER	73
	modules	14	5.4	Parameters specific to cascade systems	74
1.3.12	B2B (BACK TO BACK) layout with 5 and 6		5.5	Setting the main parameters	78
	modules	15	5.5.1	Par.2189 – module address (burner)	78
1.3.13	B2B (BACK TO BACK) layout with 7 and 8		5.5.2	Par.4147 – no. of modules (burners)	78
	modules	16	5.5.3	Par.5073 – Boiler address (cabinet)	78
1.3.14	B2B (BACK TO BACK) layout with 9 and 10		5.5.4	Par.5167 – no. of boilers (cabinets)	78
	modules	17	5.5.5	Par.2007 – heating setpoint hysteresis	78
1.4	Installation premises	18	5.5.6	Par.9097 – definition of the system with	
1.5	Air vent	19		circulator / system with two-way valve	78
			5.6	Parameter 4148: operating mode of the	
				cascade	79
2	INSTALLATION	20	5.6.1	Par 4148 = 0	79
2.1	Preliminary installation measures	20	5.6.2	Par 4148 = 1	79
2.2	Assembly of the FRAMES	21	5.6.3	Par 4148 = 2	80
2.3	Positioning the CONDENSATE PIPES	29			
2.4	Positioning the 3" MANIFOLDS	30			
2.5	Positioning the 5" MANIFOLDS	34			
2.6	Positioning the CONDENSATE OUTLET	38			
2.7	Positioning the GAS PIPES	39			
2.8	Positioning the DELIVERY-RETURN PIPES	42			
2.9	Positioning the SAFETY SECTION AND				
	SEPARATOR	46			
2.10	Neutralization of the condensate	53			
3	CONFIGURATION OF THE MAIN BLOCK				
	DIAGRAMS	54			
3.1	Configuration of the primary system	54			
3.2	Configuration of the secondary system	55			
3.3	Block diagram 1: Cascade of modules with				
	primary sensor (SS)	57			
3.3.1	Electrical power connections Block diagram 1 ..	58			
3.3.2	Sensor connections	58			
3.3.3	System parameters	59			
3.4	Block diagram 2: Cascade of modules with				
	primary sensor (SS) and secondary (SC)	60			
3.4.1	Electrical power connections Block diagram 2 ..	61			
3.4.2	Sensor connections Block diagram 2	61			
3.4.3	System parameters	62			
3.5	Block diagram 3: Cascade of cascades	63			
3.5.1	Sensor and data bus connections	64			
3.5.2	System parameters	65			
				APPENDIX	81
			I	SETTING PARAMETERS OF THE	
				ADDITIONAL ZONE	81
			I.I	Setting zone parameters (accessible only with	
				installer password)	81
			I.I.I	Menu structure	82
			I.II	Setting zone's climatic curve parameters	
				(accessible only with installer password)	84
			I.III	Programming the zone	84
			I.IV	Scheduling the time bands	85
			I.V	Information on the operation of the zone	85

The following symbols are used in this manual:



CAUTION! = Identifies actions that require caution and adequate preparation.



STOP! = Identifies actions that you MUST NOT do.

N = identifies a sequence where "N" corresponds to the number of the phase described.

1 GENERAL INFORMATION

1.1 General Safety Information



This instruction booklet is an integral part of the instruction manual of the single appliance **POWER MAX**, to which you are referred for the GENERAL WARNINGS and for the BASIC SAFETY RULES



The instructions provided for the cascade accessories are an integral part of this manual. They must be referred to and must not be disposed of.

1.2 Description of the appliance

POWER MAX can be combined in cascade with other generators in order to create modular thermal power units, consisting of modules connected hydraulically, the electronic controls of which communicate via bus. Each module is designed to be combined with other identical units. **POWER MAX** provides accessories for configurations of up to a maximum of 10 units, except for the 135 model, whose maximum number of modules in cascade is 8.

For each model it is possible to configure the different types of installations either in line (i.e. Front) or back to back (i.e. Back to Back).

Model	POWER MAX					
	65 P	80 P	100	110	130	150
No. modules	Total Cascade Power (kW)					
1	57	68	90	97	112	131
2	114	136	180	194	224	262
3	171	204	270	291	336	393
4	228	272	360	388	448	524
5	285	340	450	485	560	655
6	342	408	540	582	672	786
7	399	476	630	679	784	917
8	456	544	720	776	896	1048
9	513	612	810	873	1008	ND
10	570	680	900	970	1120	ND

1.3 System layout

1.3.1 In line lay-out (FRONT) with 2 modules

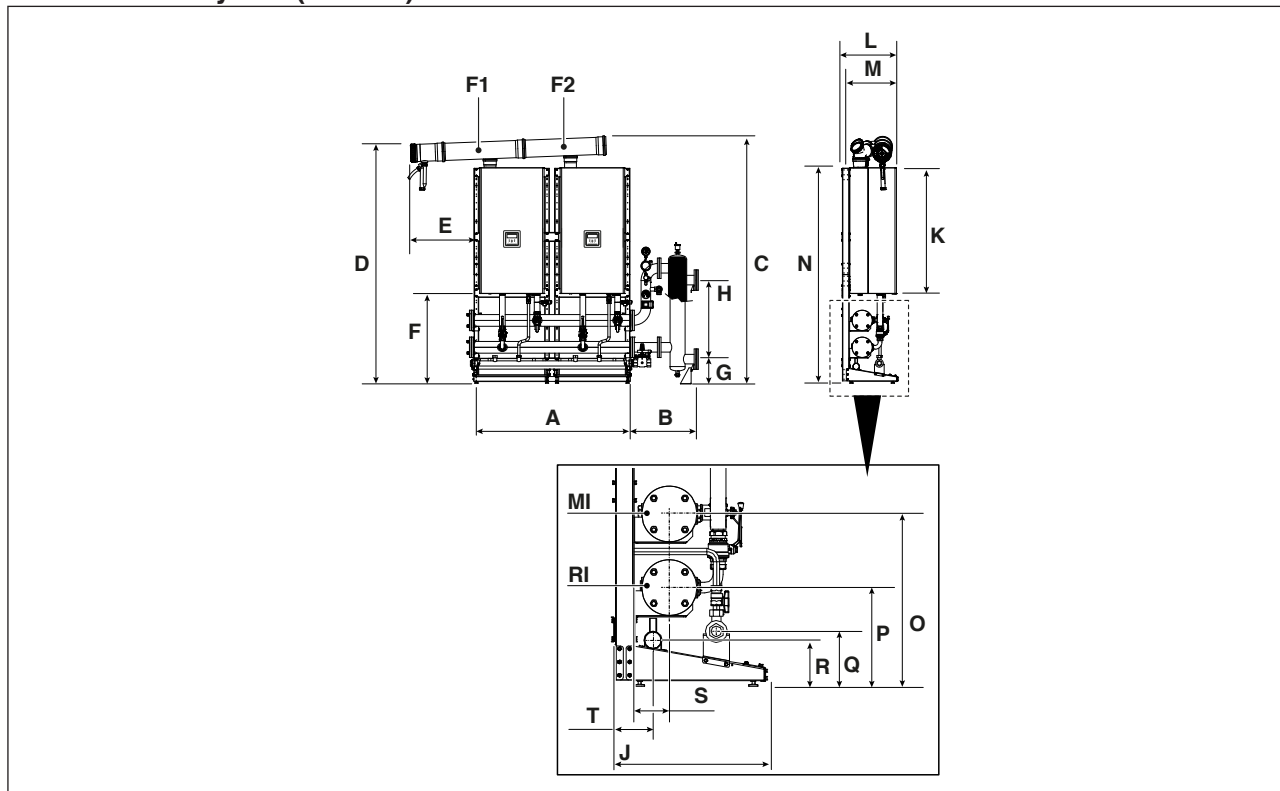

DESCRIPTION	POWER MAX							
	65 P	80 P	100	110	130	150		
A	1494	1494	1494	1494	1494	1494	mm	
B	591	591	591	591	591	591	mm	
C	2131	2131	2131	2131	2301	2301	mm	
D	2051	2051	2051	2051	2221	2221	mm	
E	594	594	594	594	594	594	mm	
F	834	834	834	834	834	834	mm	
G	230	230	230	230	230	230	mm	
H	735	735	735	735	735	735	mm	
J	525	525	525	525	525	525	mm	
K	1010	1010	1010	1010	1173	1173	mm	
L	511	511	511	511	511	511	mm	
M	436	436	436	436	436	436	mm	
N	1999	1999	1999	1999	1999	1999	mm	
O	584	584	584	584	584	584	mm	
P	334	334	334	334	334	334	mm	
Q	186	186	186	186	186	186	mm	
R	156	156	156	156	156	156	mm	
S	121	121	121	121	121	121	mm	
T	137	137	137	137	137	137	mm	
F1	Ø 160	Ø 160	Ø 160	Ø 160	Ø 160	Ø 160	mm	
F2	Ø 160	Ø 160	Ø 160	Ø 160	Ø 160	Ø 160	mm	
RI							Ø 3"	inch
MI							Ø 3"	inch

1.3.2 In line lay-out (FRONT) with 3 modules

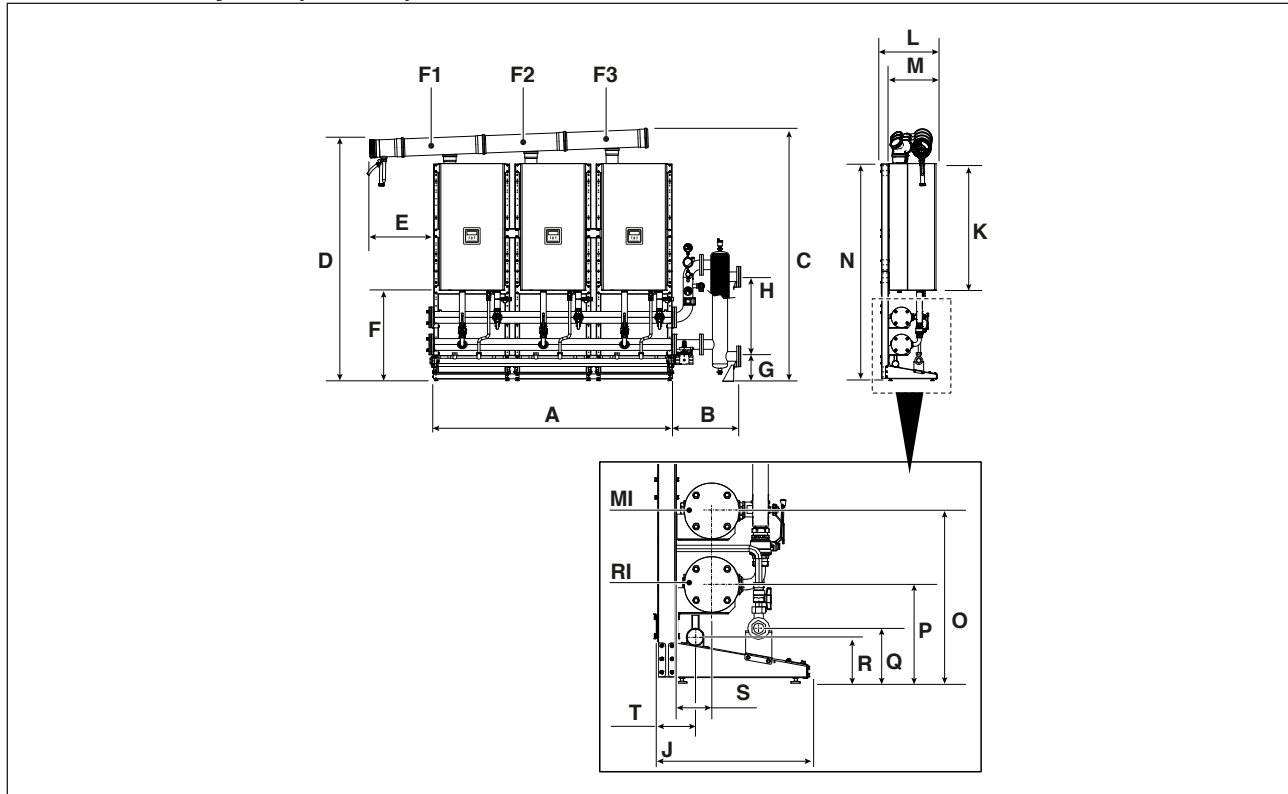

DESCRIPTION	POWER MAX							
	65 P	80 P	100	110	130	150		
A	2242	2242	2242	2242	2242	2242	mm	
B	591	591	591	591	591	591	mm	
C	2161	2161	2161	2161	2240	2240	mm	
D	2051	2051	2051	2051	2221	2221	mm	
E	594	594	594	594	594	594	mm	
F	834	834	834	834	834	834	mm	
G	230	230	230	230	230	230	mm	
H	735	735	735	735	735	735	mm	
J	525	525	525	525	525	525	mm	
K	1010	1010	1010	1010	1173	1173	mm	
L	511	511	511	511	511	511	mm	
M	436	436	436	436	436	436	mm	
N	1999	1999	1999	1999	1999	1999	mm	
O	584	584	584	584	584	584	mm	
P	334	334	334	334	334	334	mm	
Q	186	186	186	186	186	186	mm	
R	156	156	156	156	156	156	mm	
S	121	121	121	121	121	121	mm	
T	137	137	137	137	137	137	mm	
F1	Ø 160	Ø 160	Ø 160	Ø 160	Ø 160	Ø 160	mm	
F2	Ø 160	Ø 160	Ø 160	Ø 160	Ø 160	Ø 160	mm	
F3	Ø 160	Ø 160	Ø 160	Ø 160	Ø 160	Ø 160	mm	
RI							Ø 3"	inch
MI							Ø 3"	inch

1.3.3 In line lay-out (FRONT) with 4 modules

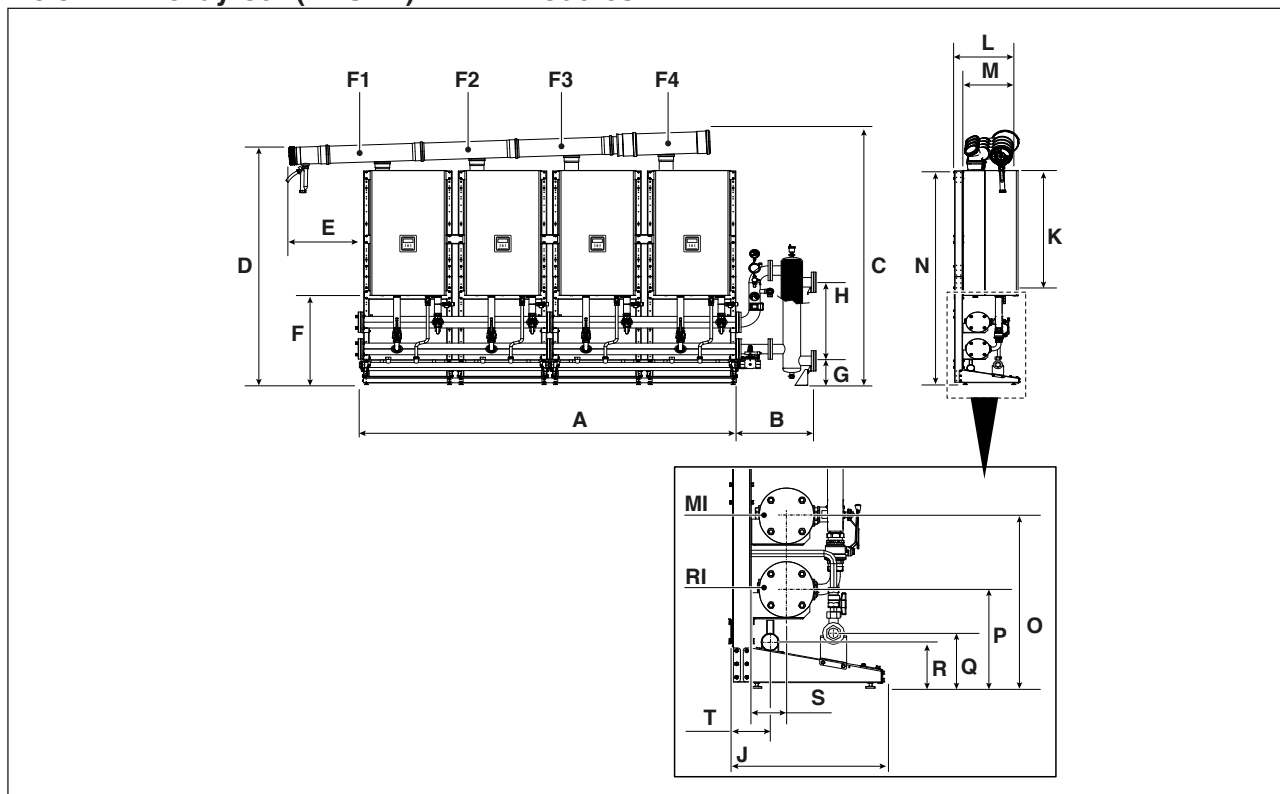

DESCRIPTION	POWER MAX						
	65 P	80 P	100	110	130	150	
A	2988	2988	2988	2988	2988	2988	mm
B	3"	591	591	591	591	591	mm
	5"	1159	1159	1159	1159	1159	mm
C	2190	2190	2190	2190	2382	2382	mm
D	2051	2051	2051	2051	2221	2221	mm
E	594	594	594	594	594	594	mm
F	834	834	834	834	834	834	mm
G	3"	230	230	230	230	N.A.	mm
	5"	N.A.	N.A.	N.A.	N.A.	N.A.	337
H	3"	735	735	735	735	N.A.	mm
	5"	N.A.	N.A.	N.A.	N.A.	N.A.	850
J	525	525	525	525	525	525	mm
K	1010	1010	1010	1010	1173	1173	mm
L	511	511	511	511	511	511	mm
M	436	436	436	436	436	436	mm
N	1999	1999	1999	1999	1999	1999	mm
O	584	584	584	584	584	584	mm
P	334	334	334	334	334	334	mm
Q	186	186	186	186	186	186	mm
R	156	156	156	156	156	156	mm
S	121	121	121	121	121	121	mm
T	137	137	137	137	137	137	mm
F1	Ø 160	Ø 160	Ø 160	Ø 160	Ø 160	Ø 160	mm
F2	Ø 160	Ø 160	Ø 160	Ø 160	Ø 160	Ø 160	mm
F3	Ø 160	Ø 160	Ø 160	Ø 160	Ø 160	Ø 160	mm
F4	Ø 160	Ø 160	Ø 160	Ø 160	Ø 160	Ø 200	mm
RI			Ø 3"			Ø 5"	inch
MI			Ø 3"			Ø 5"	inch

1.3.4 In line lay-out (FRONT) with 5 modules

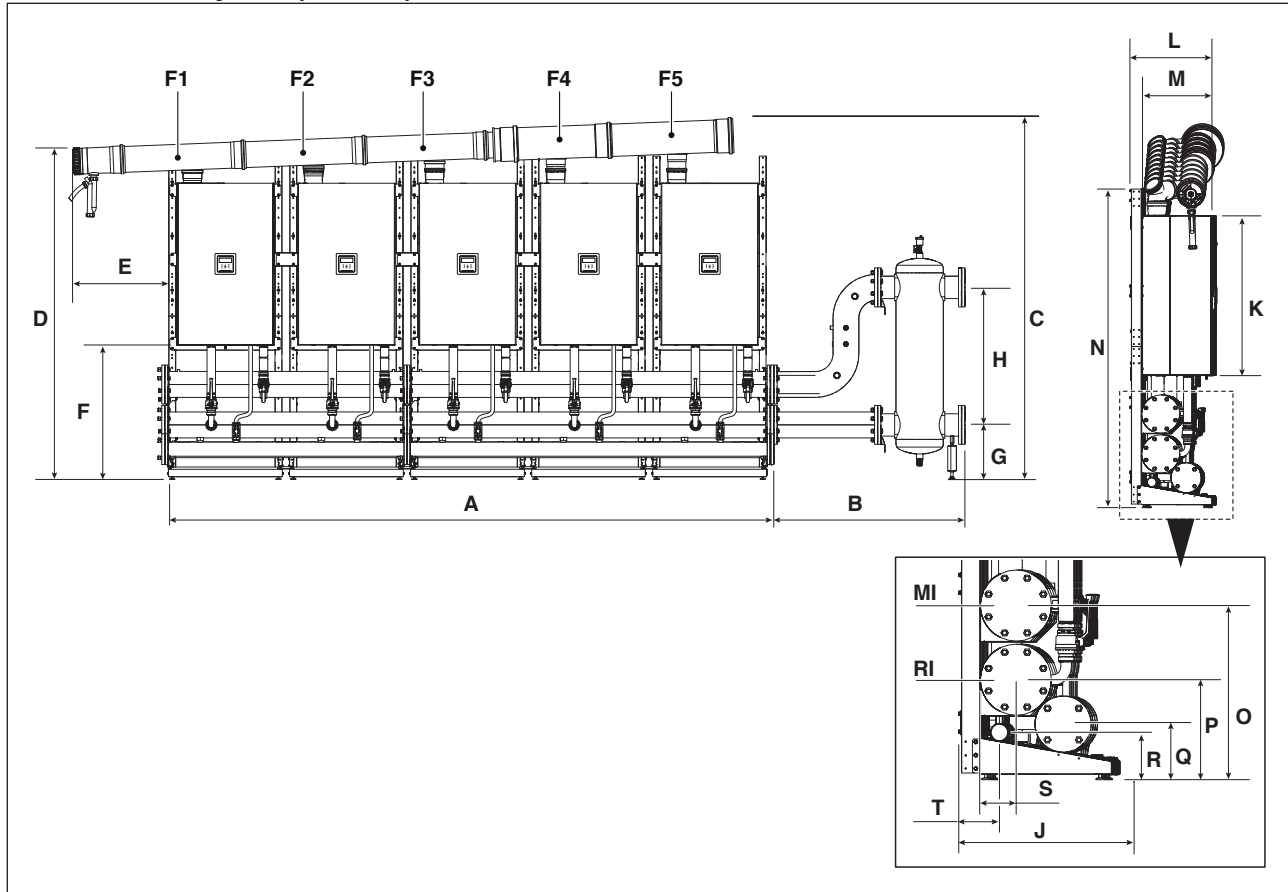

DESCRIPTION	POWER MAX						
	65 P	80 P	100	110	130	150	
A	3736	3736	3736	3736	3736	3736	mm
B	3"	591	591	591	591	591	mm
	5"	1159	1159	1159	1159	1159	mm
C	2241	2241	2241	2241	2411	2411	mm
D	2051	2051	2051	2051	2221	2221	mm
E	594	594	594	594	594	594	mm
F	834	834	834	834	834	834	mm
G	3"	230	230	230	N.A.	N.A.	mm
	5"	N.A.	N.A.	N.A.	N.A.	337	mm
H	3"	735	735	735	N.A.	N.A.	mm
	5"	N.A.	N.A.	N.A.	N.A.	850	mm
J	525	525	525	525	525	525	mm
K	1010	1010	1010	1010	1173	1173	mm
L	511	511	511	511	511	511	mm
M	436	436	436	436	436	436	mm
N	1999	1999	1999	1999	1999	1999	mm
O	584	584	584	584	584	584	mm
P	334	334	334	334	334	334	mm
Q	186	186	186	186	186	186	mm
R	156	156	156	156	156	156	mm
S	121	121	121	121	121	121	mm
T	137	137	137	137	137	137	mm
F1	Ø 160	Ø 160	Ø 160	Ø 160	Ø 160	Ø 160	mm
F2	Ø 160	Ø 160	Ø 160	Ø 160	Ø 160	Ø 160	mm
F3	Ø 160	Ø 160	Ø 160	Ø 160	Ø 160	Ø 160	mm
F4	Ø 160	Ø 160	Ø 160	Ø 160	Ø 160	Ø 200	mm
F5	Ø 160	Ø 160	Ø 200	Ø 200	Ø 200	Ø 200	mm
RI		Ø 3"			Ø 5"		inch
MI		Ø 3"			Ø 5"		inch

1.3.5 In line lay-out (FRONT) with 6 modules

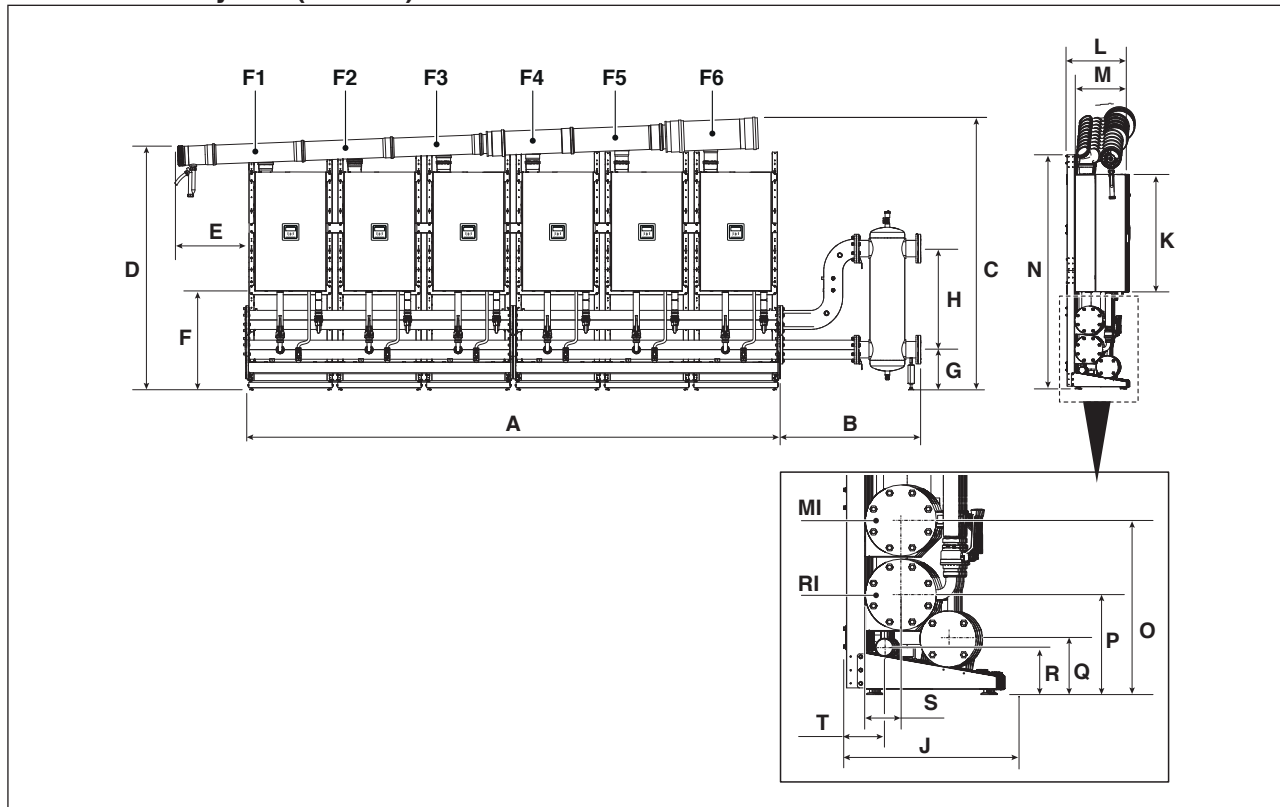

DESCRIPTION	POWER MAX						
	65 P	80 P	100	110	130	150	
A	4484	4484	4484	4484	4484	4484	mm
B	3"	591	591	591	591	591	mm
	5"	1159	1159	1159	1159	1159	mm
C	2270	2270	2270	2270	2461	2461	mm
D	2051	2051	2051	2051	2221	2221	mm
E	594	594	594	594	594	594	mm
F	834	834	834	834	834	834	mm
G	3"	230	230	N.A.	N.A.	N.A.	mm
	5"	N.A.	N.A.	337	337	337	mm
H	3"	735	735	N.A.	N.A.	N.A.	mm
	5"	N.A.	N.A.	850	850	850	mm
J	525	525	525	525	525	525	mm
K	1010	1010	1010	1010	1173	1173	mm
L	511	511	511	511	511	511	mm
M	436	436	436	436	436	436	mm
N	1999	1999	1999	1999	1999	1999	mm
O	584	584	584	584	584	584	mm
P	334	334	334	334	334	334	mm
Q	186	186	186	186	186	186	mm
R	156	156	156	156	156	156	mm
S	121	121	121	121	121	121	mm
T	137	137	137	137	137	137	mm
F1	Ø 160	Ø 160	Ø 160	Ø 160	Ø 160	Ø 160	mm
F2	Ø 160	Ø 160	Ø 160	Ø 160	Ø 160	Ø 160	mm
F3	Ø 160	Ø 160	Ø 160	Ø 160	Ø 160	Ø 160	mm
F4	Ø 160	Ø 160	Ø 160	Ø 160	Ø 160	Ø 200	mm
F5	Ø 160	Ø 160	Ø 200	Ø 200	Ø 200	Ø 200	mm
F6	Ø 160	Ø 160	Ø 200	Ø 200	Ø 200	Ø 250	mm
RI	Ø 3"		Ø 5"				inch
MI	Ø 3"		Ø 5"				inch

1.3.6 In line lay-out (FRONT) with 7 modules

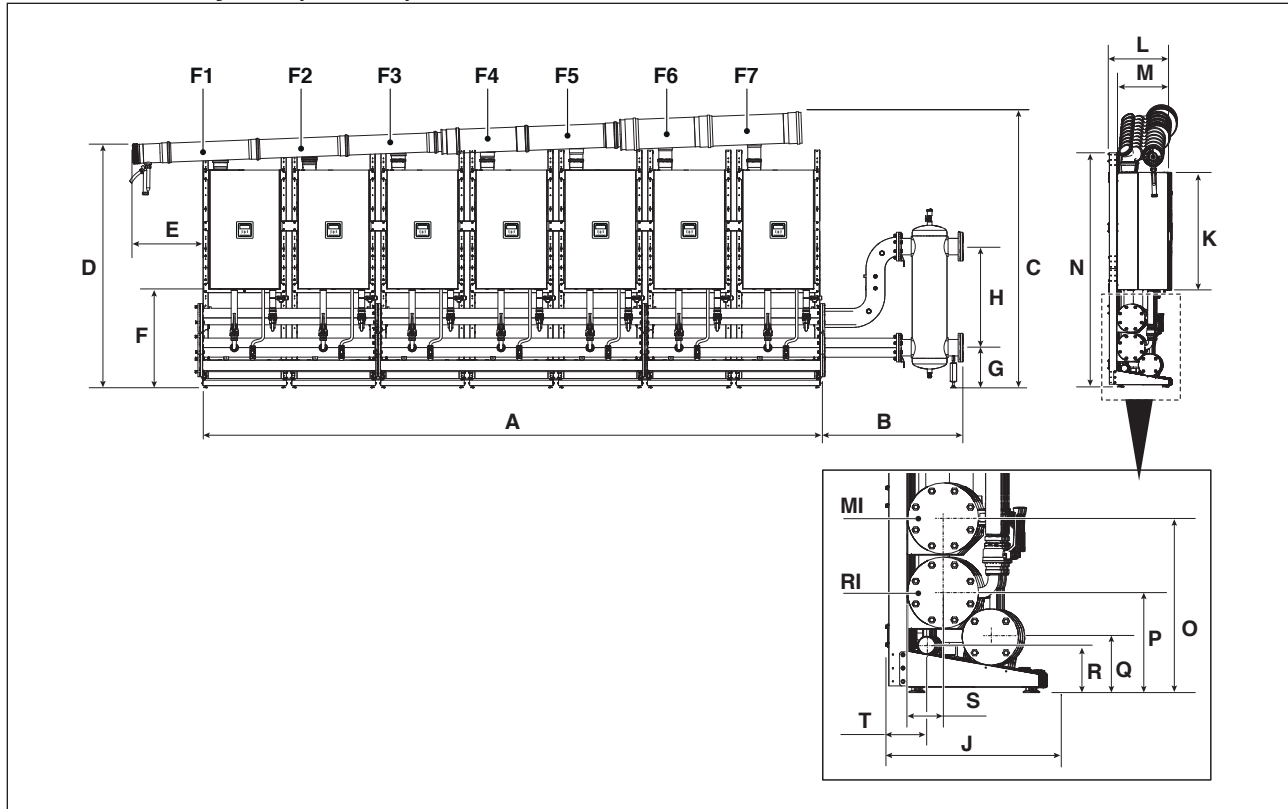

DESCRIPTION	POWER MAX						
	65 P	80 P	100	110	130	150	
A	5230	5230	5230	5230	5230	5230	mm
B	3"	591	591	591	591	591	mm
	5"	1159	1159	1159	1159	1159	mm
C	2295	2295	2295	2295	2490	2490	mm
D	2051	2051	2051	2051	2221	2221	mm
E	594	594	594	594	594	594	mm
F	834	834	834	834	834	834	mm
G	3"	230	230	N.A.	N.A.	N.A.	mm
	5"	N.A.	N.A.	337	337	337	mm
H	3"	735	735	N.A.	N.A.	N.A.	mm
	5"	N.A.	N.A.	850	850	850	mm
J	525	525	525	525	525	525	mm
K	1010	1010	1010	1010	1173	1173	mm
L	511	511	511	511	511	511	mm
M	436	436	436	436	436	436	mm
N	1999	1999	1999	1999	1999	1999	mm
O	584	584	584	584	584	584	mm
P	334	334	334	334	334	334	mm
Q	186	186	186	186	186	186	mm
R	156	156	156	156	156	156	mm
S	121	121	121	121	121	121	mm
T	137	137	137	137	137	137	mm
F1	Ø 160	Ø 160	Ø 160	Ø 160	Ø 160	Ø 160	mm
F2	Ø 160	Ø 160	Ø 160	Ø 160	Ø 160	Ø 160	mm
F3	Ø 160	Ø 160	Ø 160	Ø 160	Ø 160	Ø 160	mm
F4	Ø 160	Ø 160	Ø 160	Ø 160	Ø 160	Ø 200	mm
F5	Ø 160	Ø 160	Ø 200	Ø 200	Ø 200	Ø 200	mm
F6	Ø 160	Ø 160	Ø 200	Ø 200	Ø 200	Ø 250	mm
F7	Ø 160	Ø 200	Ø 200	Ø 200	Ø 250	Ø 250	mm
RI	Ø 3"			Ø 5"			inch
MI	Ø 3"			Ø 5"			inch

1.3.7 In line lay-out (FRONT) with 8 modules

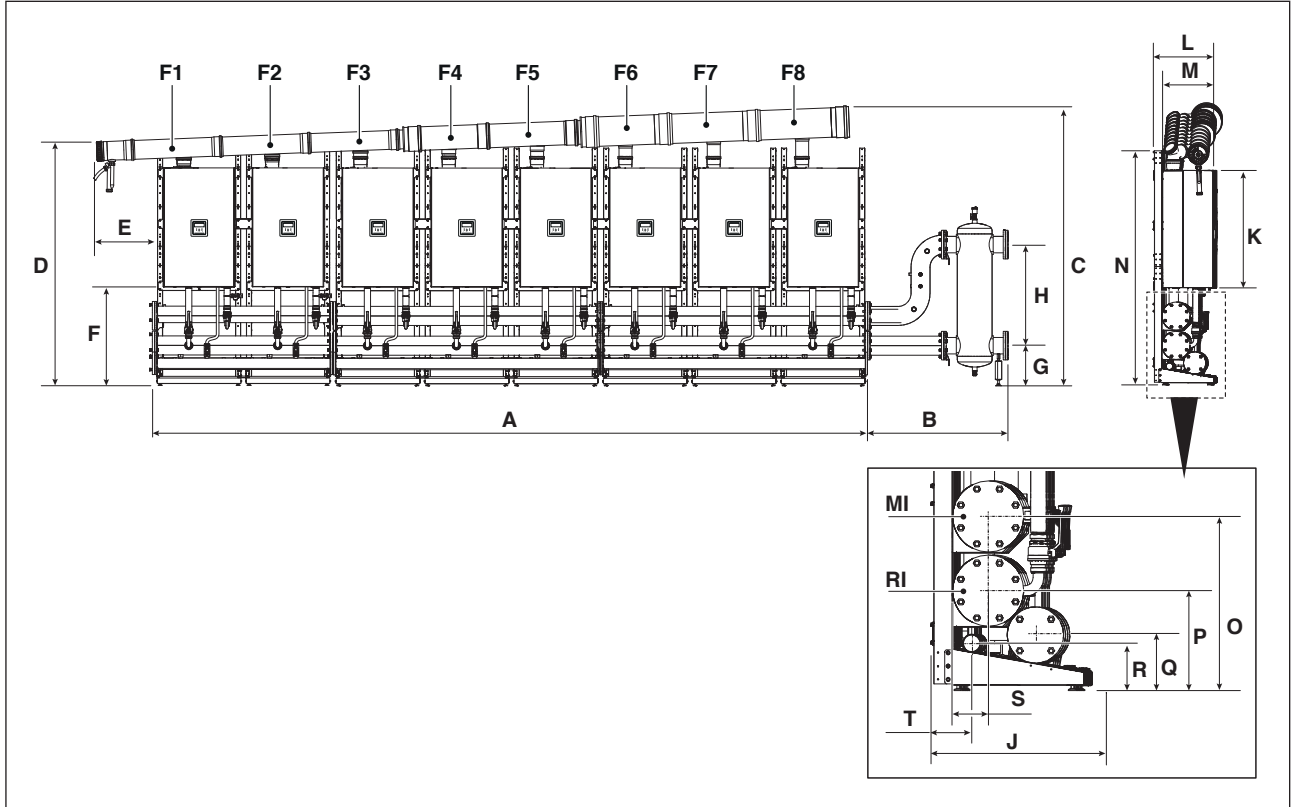

DESCRIPTION	POWER MAX						
	65 P	80 P	100	110	130	150	
A	5978	5978	5978	5978	5978	5978	mm
B	1159	1159	1159	1159	1159	1159	mm
C	2346	2346	2346	2346	2519	2519	mm
D	2051	2051	2051	2051	2221	2221	mm
E	594	594	594	594	594	594	mm
F	834	834	834	834	834	834	mm
G	3"	230	N.A.	N.A.	N.A.	N.A.	mm
	5"	N.A.	337	337	337	337	mm
H	3"	735	N.A.	N.A.	N.A.	N.A.	mm
	5"	N.A.	850	850	850	850	mm
J	525	525	525	525	525	525	mm
K	1010	1010	1010	1010	1173	1173	mm
L	511	511	511	511	511	511	mm
M	436	436	436	436	436	436	mm
N	1999	1999	1999	1999	1999	1999	mm
O	584	584	584	584	584	584	mm
P	334	334	334	334	334	334	mm
Q	186	186	186	186	186	186	mm
R	156	156	156	156	156	156	mm
S	121	121	121	121	121	121	mm
T	137	137	137	137	137	137	mm
F1	Ø 160	Ø 160	Ø 160	Ø 160	Ø 160	Ø 160	mm
F2	Ø 160	Ø 160	Ø 160	Ø 160	Ø 160	Ø 160	mm
F3	Ø 160	Ø 160	Ø 160	Ø 160	Ø 160	Ø 160	mm
F4	Ø 160	Ø 160	Ø 160	Ø 160	Ø 160	Ø 200	mm
F5	Ø 160	Ø 160	Ø 200	Ø 200	Ø 200	Ø 200	mm
F6	Ø 160	Ø 160	Ø 200	Ø 200	Ø 200	Ø 250	mm
F7	Ø 160	Ø 200	Ø 200	Ø 200	Ø 250	Ø 250	mm
F8	Ø 200	Ø 200	Ø 250	Ø 250	Ø 250	Ø 250	mm
RI	Ø 3"			Ø 5"			inch
MI	Ø 3"			Ø 5"			inch

1.3.8 In line lay-out (FRONT) with 9 modules

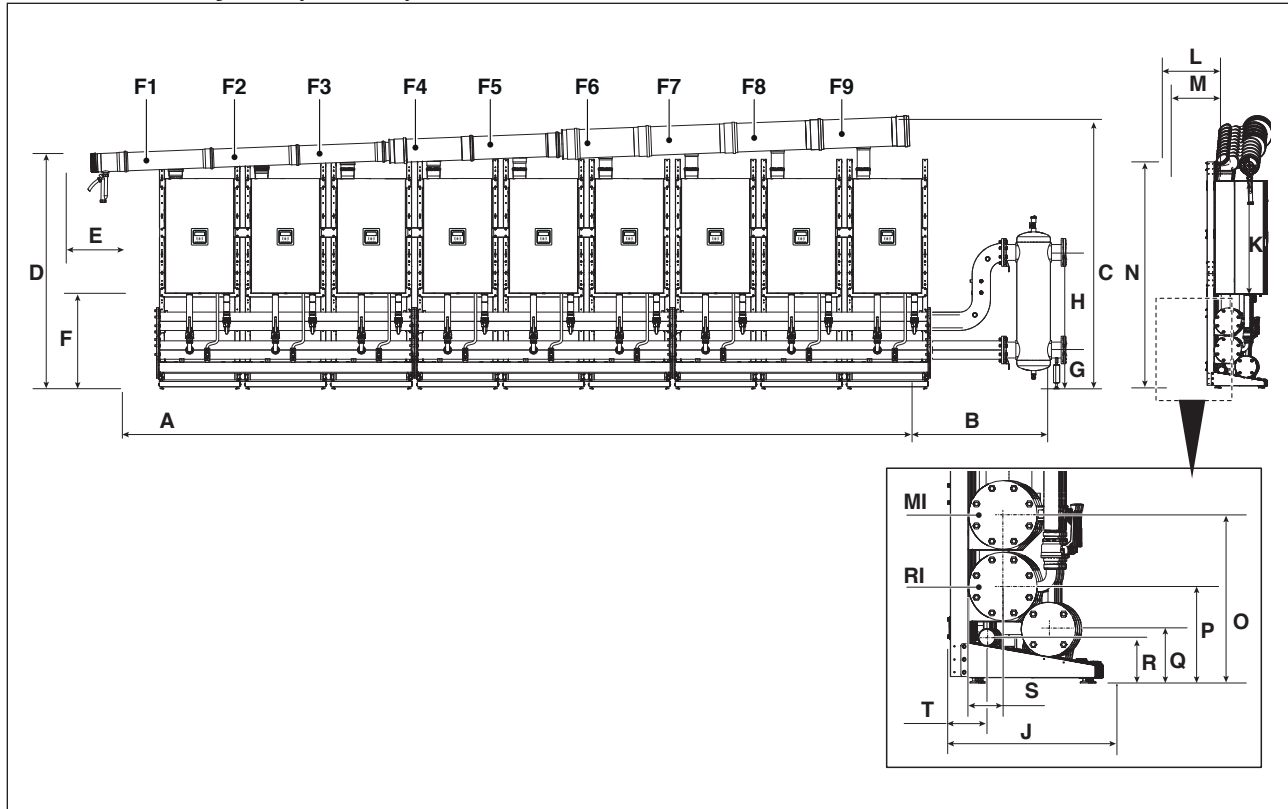

DESCRIPTION	POWER MAX							
	65 P	80 P	100	110	130	150		
A	6726	6726	6726	6726	6726	N.A.	mm	
B	1159	1159	1159	1159	1159	N.A.	mm	
C	2376	2376	2376	2376	2548	N.A.	mm	
D	2051	2051	2051	2051	2221	N.A.	mm	
E	594	594	594	594	594	N.A.	mm	
F	834	834	834	834	834	N.A.	mm	
G	3"	N.A.	N.A.	N.A.	N.A.	N.A.	mm	
	5"	337	337	337	337	337	mm	
H	3"	N.A.	N.A.	N.A.	N.A.	N.A.	mm	
	5"	850	850	850	850	850	mm	
J	525	525	525	525	525	N.A.	mm	
K	1010	1010	1010	1010	1173	N.A.	mm	
L	511	511	511	511	511	N.A.	mm	
M	436	436	436	436	436	N.A.	mm	
N	1999	1999	1999	1999	1999	N.A.	mm	
O	584	584	584	584	584	N.A.	mm	
P	334	334	334	334	334	N.A.	mm	
Q	186	186	186	186	186	N.A.	mm	
R	156	156	156	156	156	N.A.	mm	
S	121	121	121	121	121	N.A.	mm	
T	137	137	137	137	137	N.A.	mm	
F1	Ø 160	Ø 160	Ø 160	Ø 160	Ø 160	N.A.	mm	
F2	Ø 160	Ø 160	Ø 160	Ø 160	Ø 160	N.A.	mm	
F3	Ø 160	Ø 160	Ø 160	Ø 160	Ø 160	N.A.	mm	
F4	Ø 160	Ø 160	Ø 160	Ø 160	Ø 160	N.A.	mm	
F5	Ø 160	Ø 160	Ø 200	Ø 200	Ø 200	N.A.	mm	
F6	Ø 160	Ø 160	Ø 200	Ø 200	Ø 200	N.A.	mm	
F7	Ø 160	Ø 200	Ø 200	Ø 200	Ø 250	N.A.	mm	
F8	Ø 200	Ø 200	Ø 250	Ø 250	Ø 250	N.A.	mm	
F9	Ø 200	Ø 200	Ø 250	Ø 250	Ø 250	N.A.	mm	
RI							Ø 5"	inch
MI							Ø 5"	inch

1.3.9 In line lay-out (FRONT) with 10 modules

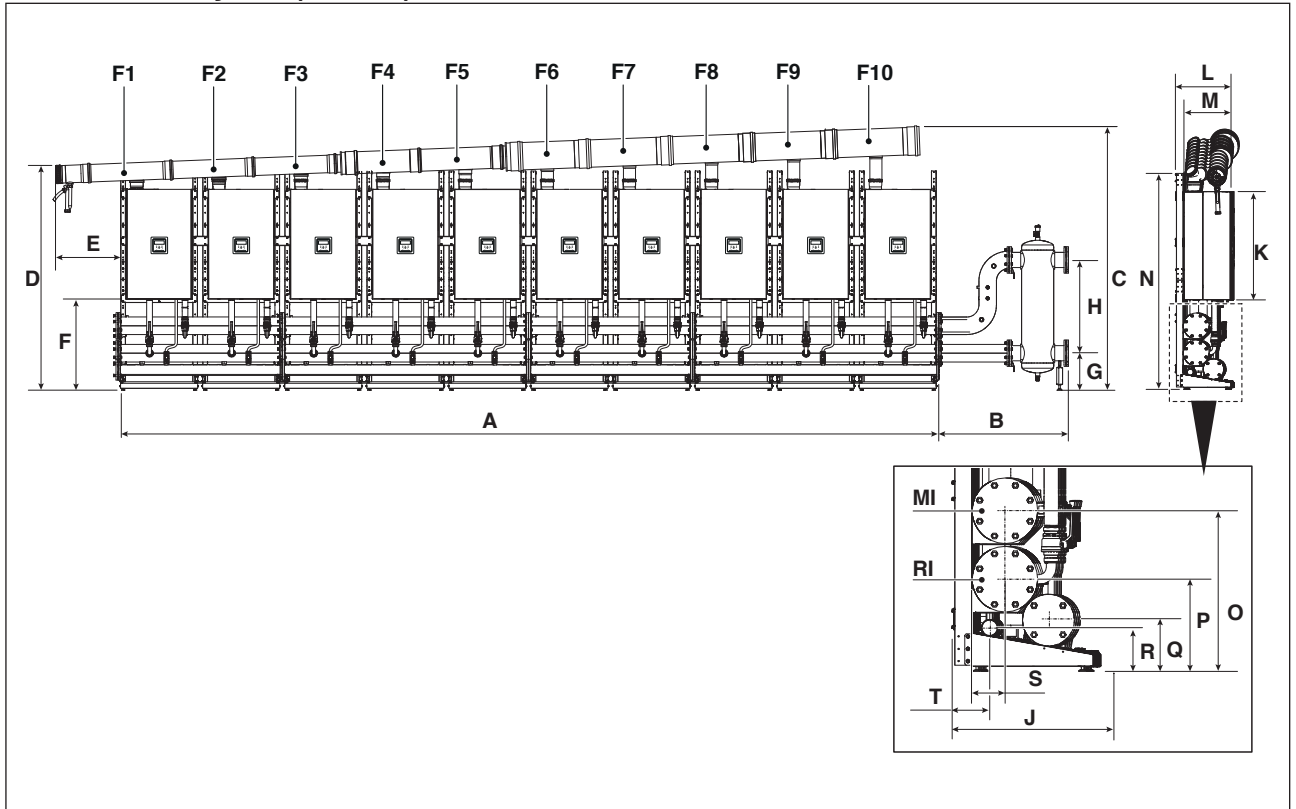

DESCRIPTION	POWER MAX							
	65 P	80 P	100	110	130	150		
A	7472	7472	7472	7472	7472	N.A.	mm	
B	1159	1159	1159	1159	1159	N.A.	mm	
C	2405	2405	2405	2405	2578	N.A.	mm	
D	2051	2051	2051	2051	2221	N.A.	mm	
E	594	594	594	594	594	N.A.	mm	
F	834	834	834	834	834	N.A.	mm	
G	3"	N.A.	N.A.	N.A.	N.A.	N.A.	mm	
	5"	337	337	337	337	337	mm	
H	3"	N.A.	N.A.	N.A.	N.A.	N.A.	mm	
	5"	850	850	850	850	850	mm	
J	525	525	525	525	525	N.A.	mm	
K	1010	1010	1010	1010	1173	N.A.	mm	
L	511	511	511	511	511	N.A.	mm	
M	436	436	436	436	436	N.A.	mm	
N	1999	1999	1999	1999	1999	N.A.	mm	
O	584	584	584	584	584	N.A.	mm	
P	334	334	334	334	334	N.A.	mm	
Q	186	186	186	186	186	N.A.	mm	
R	156	156	156	156	156	N.A.	mm	
S	121	121	121	121	121	N.A.	mm	
T	137	137	137	137	137	N.A.	mm	
F1	Ø 160	Ø 160	Ø 160	Ø 160	Ø 160	N.A.	mm	
F2	Ø 160	Ø 160	Ø 160	Ø 160	Ø 160	N.A.	mm	
F3	Ø 160	Ø 160	Ø 160	Ø 160	Ø 160	N.A.	mm	
F4	Ø 160	Ø 160	Ø 160	Ø 160	Ø 160	N.A.	mm	
F5	Ø 160	Ø 160	Ø 200	Ø 200	Ø 200	N.A.	mm	
F6	Ø 160	Ø 160	Ø 200	Ø 200	Ø 200	N.A.	mm	
F7	Ø 160	Ø 200	Ø 200	Ø 200	Ø 250	N.A.	mm	
F8	Ø 200	Ø 200	Ø 250	Ø 250	Ø 250	N.A.	mm	
F9	Ø 200	Ø 200	Ø 250	Ø 250	Ø 250	N.A.	mm	
F10	Ø 200	Ø 200	Ø 250	Ø 250	Ø 250	N.A.	mm	
RI							Ø 5"	inch
MI							Ø 5"	inch

1.3.10 B2B (BACK TO BACK) layout with 2 modules

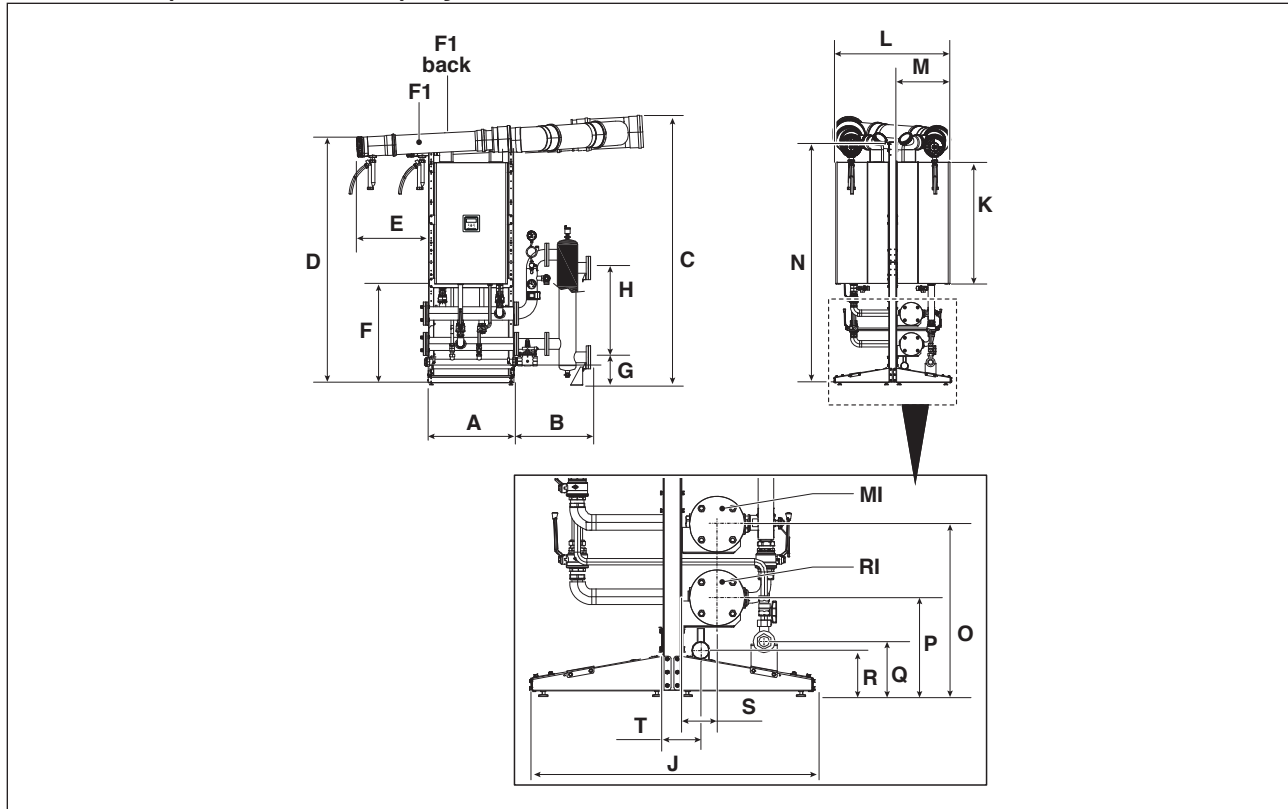

DESCRIPTION	POWER MAX							
	65 P	80 P	100	110	130	150		
A	746	746	746	746	746	746	mm	
B	591	591	591	591	591	591	mm	
C	2220	2220	2220	2220	2390	2390	mm	
D	2051	2051	2051	2051	2221	2221	mm	
E	594	594	594	594	594	594	mm	
F	834	834	834	834	834	834	mm	
G	230	230	230	230	230	230	mm	
H	735	735	735	735	735	735	mm	
J	969	969	969	969	969	969	mm	
K	1010	1010	1010	1010	1173	1173	mm	
L	942	942	942	942	942	942	mm	
M	436	436	436	436	436	436	mm	
N	1999	1999	1999	1999	1999	1999	mm	
O	584	584	584	584	584	584	mm	
P	334	334	334	334	334	334	mm	
Q	186	186	186	186	186	186	mm	
R	156	156	156	156	156	156	mm	
S	121	121	121	121	121	121	mm	
T	137	137	137	137	137	137	mm	
F1	Ø 160	Ø 160	Ø 160	Ø 160	Ø 160	Ø 160	mm	
F1 back	Ø 160	Ø 160	Ø 160	Ø 160	Ø 160	Ø 160	mm	
RI							Ø 3"	inch
MI							Ø 3"	inch

1.3.11 B2B (BACK TO BACK) layout with 3 and 4 modules

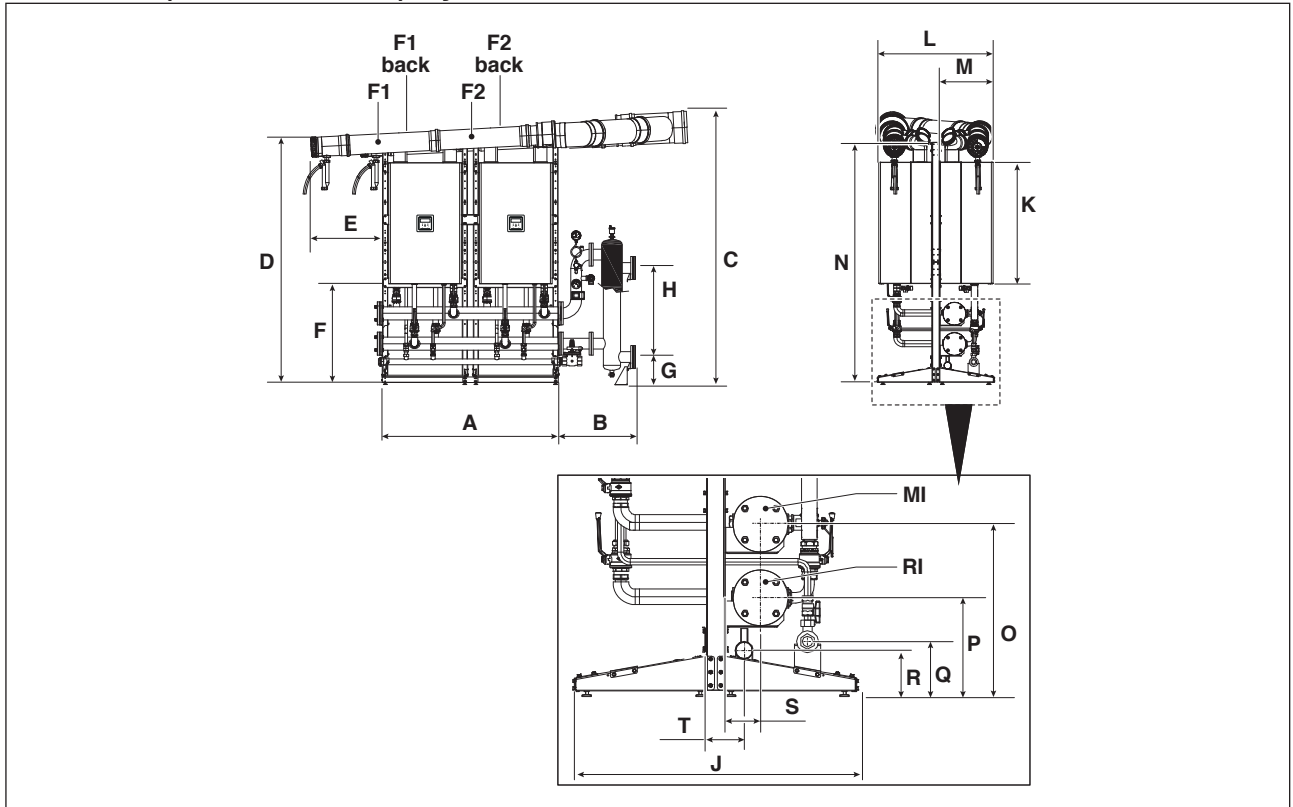

DESCRIPTION	POWER MAX							
	65 P	80 P	100	110	130	150		
A	1494	1494	1494	1494	1494	1494	mm	
B	3"	591	591	591	591	591	mm	
	5"	1159	1159	1159	1159	1159	mm	
C	2260	2260	2260	2260	2430	2430	mm	
D	2051	2051	2051	2051	2221	2221	mm	
E	594	594	594	594	594	594	mm	
F	834	834	834	834	834	834	mm	
G	3"	230	230	230	230	230	mm	
	5"	N.A.	N.A.	N.A.	N.A.	N.A.	337	
H	3"	735	735	735	735	735	mm	
	5"	N.A.	N.A.	N.A.	N.A.	N.A.	850	
J	969	969	969	969	969	969	mm	
K	1010	1010	1010	1010	1173	1173	mm	
L	942	942	942	942	942	942	mm	
M	436	436	436	436	436	436	mm	
N	1999	1999	1999	1999	1999	1999	mm	
O	584	584	584	584	584	584	mm	
P	334	334	334	334	334	334	mm	
Q	186	186	186	186	186	186	mm	
R	156	156	156	156	156	156	mm	
S	121	121	121	121	121	121	mm	
T	137	137	137	137	137	137	mm	
F1	Ø 160	Ø 160	Ø 160	Ø 160	Ø 160	Ø 160	mm	
F1 back	Ø 160	Ø 160	Ø 160	Ø 160	Ø 160	Ø 160	mm	
F2	Ø 160	Ø 160	Ø 160	Ø 160	Ø 160	Ø 160	mm	
F2 back	Ø 160	Ø 160	Ø 160	Ø 160	Ø 160	Ø 160	mm	
RI	3 modules			Ø 3"			Ø 3"	inch
	4 modules			Ø 3"			Ø 5"	inch
MI	3 modules			Ø 3"			Ø 3"	inch
	4 modules			Ø 3"			Ø 5"	inch

1.3.12 B2B (BACK TO BACK) layout with 5 and 6 modules

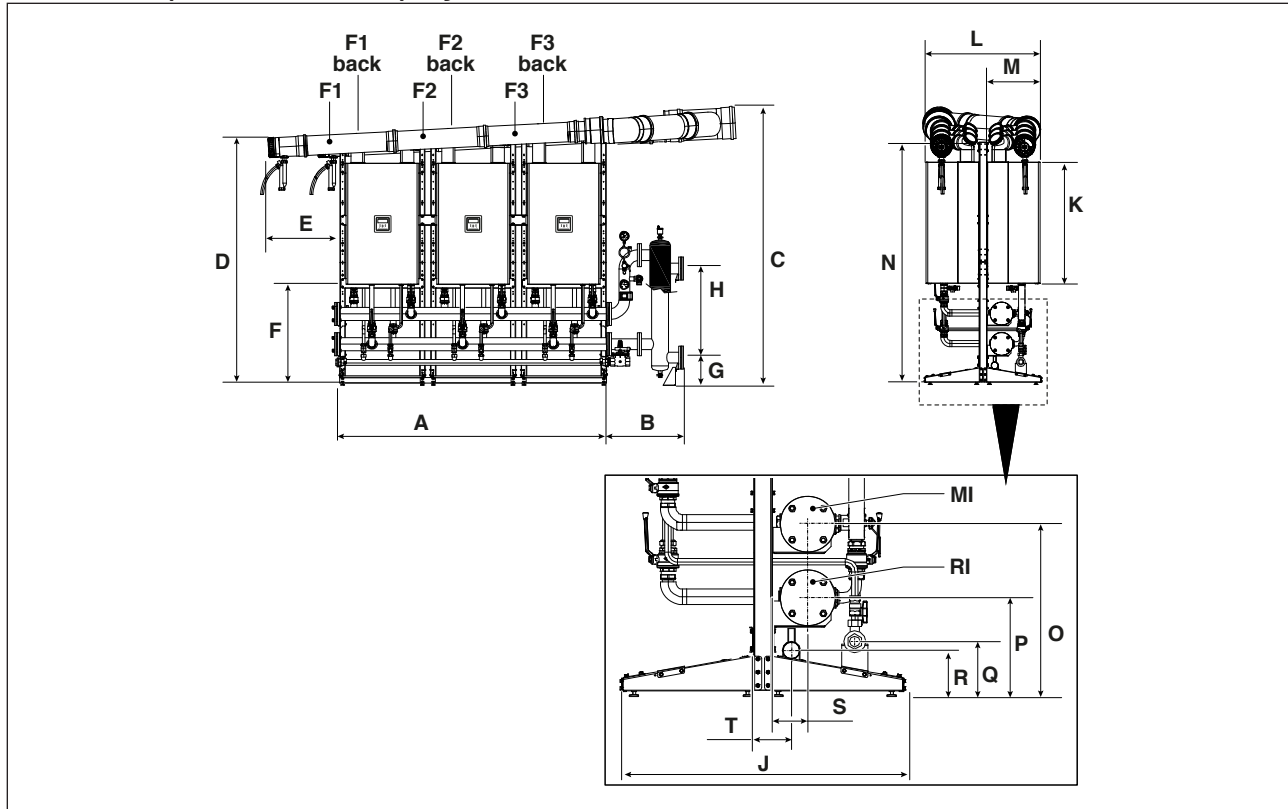

DESCRIPTION	POWER MAX						
	65 P	80 P	100	110	130	150	
A	2242	2242	2242	2242	2242	2242	mm
B	3"	591	591	591	591	591	mm
	5"	1159	1159	1159	1159	1159	mm
C	2299	2299	2299	2299	2469	2469	mm
D	2051	2051	2051	2051	2221	2221	mm
E	594	594	594	594	594	594	mm
F	834	834	834	834	834	834	mm
G	3"	230	230	230	N.A.	N.A.	mm
	5"	N.A.	N.A.	337	337	337	mm
H	3"	735	735	735	N.A.	N.A.	mm
	5"	N.A.	N.A.	850	850	850	mm
J	969	969	969	969	969	969	mm
K	1010	1010	1010	1010	1173	1173	mm
L	942	942	942	942	942	942	mm
M	436	436	436	436	436	436	mm
N	1999	1999	1999	1999	1999	1999	mm
O	584	584	584	584	584	584	mm
P	334	334	334	334	334	334	mm
Q	186	186	186	186	186	186	mm
R	156	156	156	156	156	156	mm
S	121	121	121	121	121	121	mm
T	137	137	137	137	137	137	mm
F1	Ø 160	Ø 160	Ø 160	Ø 160	Ø 160	Ø 160	mm
F1 back	Ø 160	Ø 160	Ø 160	Ø 160	Ø 160	Ø 160	mm
F2	Ø 160	Ø 160	Ø 160	Ø 160	Ø 160	Ø 160	mm
F2 back	Ø 160	Ø 160	Ø 160	Ø 160	Ø 160	Ø 160	mm
F3	Ø 160	Ø 160	Ø 160	Ø 160	Ø 160	Ø 160	mm
F3 back	Ø 160	Ø 160	Ø 160	Ø 160	Ø 160	Ø 160	mm
Ri	5 modules	Ø 3"		Ø 3"		Ø 5"	inch
	6 modules	Ø 3"		Ø 5"		Ø 5"	inch
MI	5 modules	Ø 3"		Ø 3"		Ø 5"	inch
	6 modules	Ø 3"		Ø 5"		Ø 5"	inch

1.3.13 B2B (BACK TO BACK) layout with 7 and 8 modules

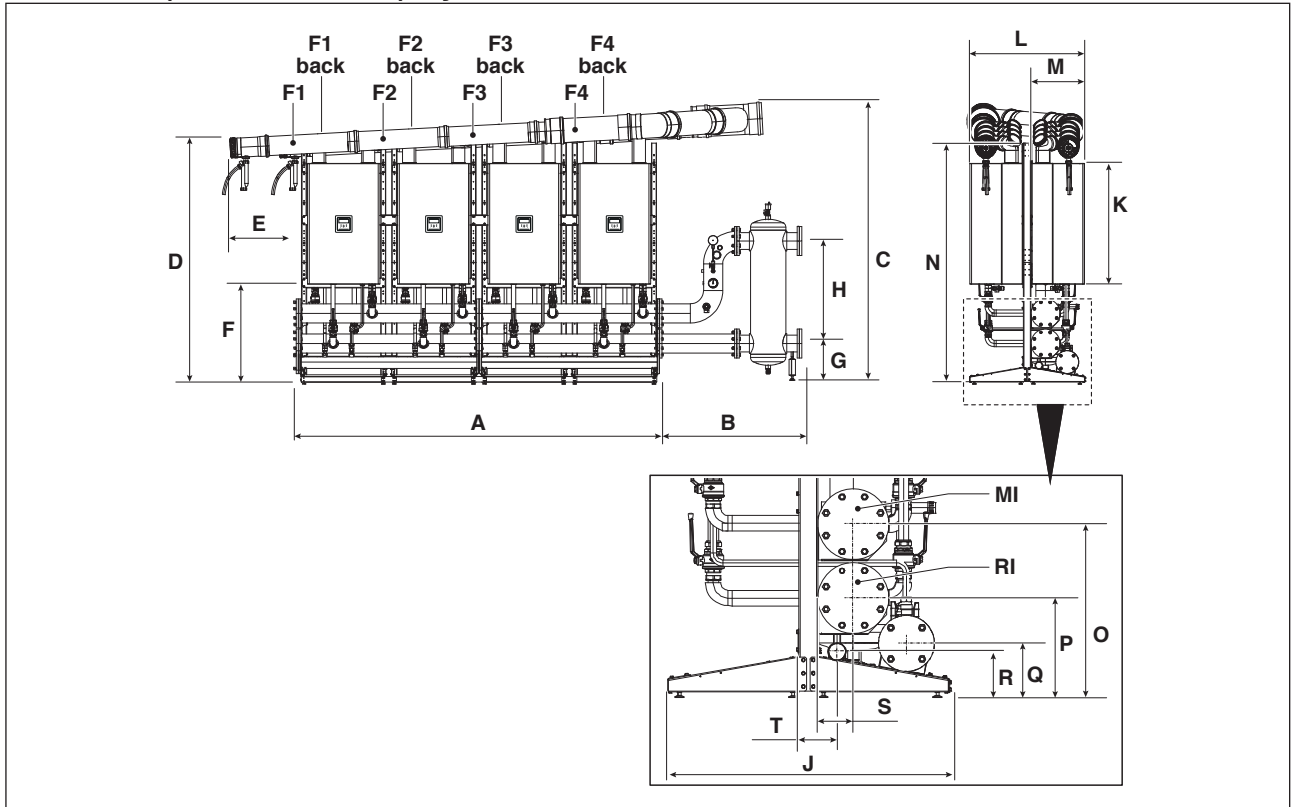

DESCRIPTION	POWER MAX						
	65 P	80 P	100	110	130	150	
A	2988	2988	2988	2988	2988	2988	mm
B	3"	591	591	591	591	591	mm
	5"	1159	1159	1159	1159	1159	mm
C	2339	2339	2339	2339	2509	2509	mm
D	2051	2051	2051	2051	2221	2221	mm
E	594	594	594	594	594	594	mm
F	834	834	834	834	834	834	mm
G	3"	230	230	N.A.	N.A.	N.A.	mm
	5"	N.A.	337	337	337	337	mm
H	3"	735	735	N.A.	N.A.	N.A.	mm
	5"	N.A.	850	850	850	850	mm
J	969	969	969	969	969	969	mm
K	1010	1010	1010	1010	1173	1173	mm
L	942	942	942	942	942	942	mm
M	436	436	436	436	436	436	mm
N	1999	1999	1999	1999	1999	1999	mm
O	584	584	584	584	584	584	mm
P	334	334	334	334	334	334	mm
Q	186	186	186	186	186	186	mm
R	156	156	156	156	156	156	mm
S	121	121	121	121	121	121	mm
T	137	137	137	137	137	137	mm
F1	Ø 160	Ø 160	Ø 160	Ø 160	Ø 160	Ø 160	mm
F1 back	Ø 160	Ø 160	Ø 160	Ø 160	Ø 160	Ø 160	mm
F2	Ø 160	Ø 160	Ø 160	Ø 160	Ø 160	Ø 160	mm
F2 back	Ø 160	Ø 160	Ø 160	Ø 160	Ø 160	Ø 160	mm
F3	Ø 160	Ø 160	Ø 160	Ø 160	Ø 160	Ø 160	mm
F3 back	Ø 160	Ø 160	Ø 160	Ø 160	Ø 160	Ø 160	mm
F4	Ø 160	Ø 160	Ø 160	Ø 160	Ø 160	Ø 200	mm
F4 back	Ø 160	Ø 160	Ø 160	Ø 160	Ø 160	Ø 200	mm
RI	7 modules	Ø 3"	Ø 3"		Ø 5"		inch
	8 modules	Ø 3"	Ø 5"		Ø 5"		inch
MI	7 modules	Ø 3"	Ø 3"		Ø 5"		inch
	8 modules	Ø 3"	Ø 5"		Ø 5"		inch

1.3.14 B2B (BACK TO BACK) layout with 9 and 10 modules

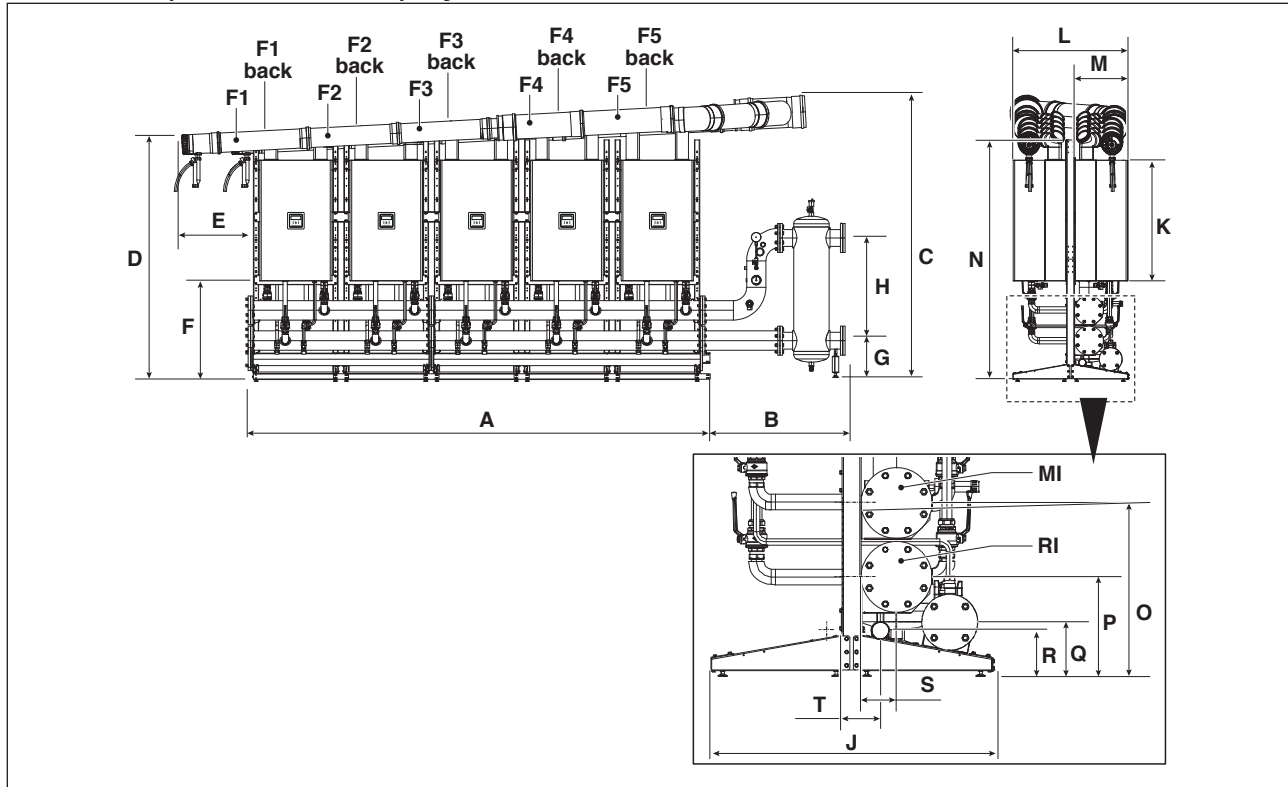

DESCRIPTION		POWER MAX							
		65 P	80 P	100	110	130	150		
A		3736	3736	3736	3736	3736	N.A.	mm	
B		1159	1159	1159	1159	1159	N.A.	mm	
C		2367	2367	2367	2367	2537	N.A.	mm	
D		2051	2051	2051	2051	2221	N.A.	mm	
E		594	594	594	594	594	N.A.	mm	
F		834	834	834	834	834	N.A.	mm	
G	9 modules	3"	N.A.	N.A.	N.A.	N.A.	N.A.	N.A.	mm
		5"	337	337	337	337	337	N.A.	mm
	10 modules	3"	N.A.	N.A.	N.A.	N.A.	N.A.	N.A.	mm
		5"	337	337	337	337	337	N.A.	mm
H	9 modules	3"	N.A.	N.A.	N.A.	N.A.	N.A.	N.A.	mm
		5"	850	850	850	850	850	N.A.	mm
	10 modules	3"	N.A.	N.A.	N.A.	N.A.	N.A.	N.A.	mm
		5"	850	850	850	850	850	N.A.	mm
J		969	969	969	969	969	N.A.	mm	
K		1010	1010	1010	1010	1173	N.A.	mm	
L		942	942	942	942	942	N.A.	mm	
M		436	436	436	436	436	N.A.	mm	
N		1999	1999	1999	1999	1999	N.A.	mm	
O		584	584	584	584	584	N.A.	mm	
P		334	334	334	334	334	N.A.	mm	
Q		186	186	186	186	186	N.A.	mm	
R		156	156	156	156	156	N.A.	mm	
S		121	121	121	121	121	N.A.	mm	
T		137	137	137	137	137	N.A.	mm	
F1		Ø 160	Ø 160	Ø 160	Ø 160	Ø 160	N.A.	mm	
F1 back		Ø 160	Ø 160	Ø 160	Ø 160	Ø 160	N.A.	mm	
F2		Ø 160	Ø 160	Ø 160	Ø 160	Ø 160	N.A.	mm	
F2 back		Ø 160	Ø 160	Ø 160	Ø 160	Ø 160	N.A.	mm	
F3		Ø 160	Ø 160	Ø 160	Ø 160	Ø 160	N.A.	mm	
F3 back		Ø 160	Ø 160	Ø 160	Ø 160	Ø 160	N.A.	mm	
F4		Ø 160	Ø 160	Ø 160	Ø 160	Ø 160	N.A.	mm	
F4 back		Ø 160	Ø 160	Ø 160	Ø 160	Ø 160	N.A.	mm	
F5		Ø 160	Ø 160	Ø 200	Ø 200	Ø 200	N.A.	mm	
F5 back		Ø 160	Ø 160	Ø 200	Ø 200	Ø 200	N.A.	mm	
RI	9 modules	Ø 5"						inch	
	10 modules	Ø 5"						inch	
MI	9 modules	Ø 5"						inch	
	10 modules	Ø 5"						inch	

1.4 Installation premises

The module must be installed in premises used exclusively for the latter conforming to standards and legislation in force and where combustion exhaust products and combustion air intake is conveyed out of said premises.

Where combustion air is instead taken from the installation premises then the latter must be equipped with suitably sized vents conforming to standards.

Space required for in line layout (FRONT)

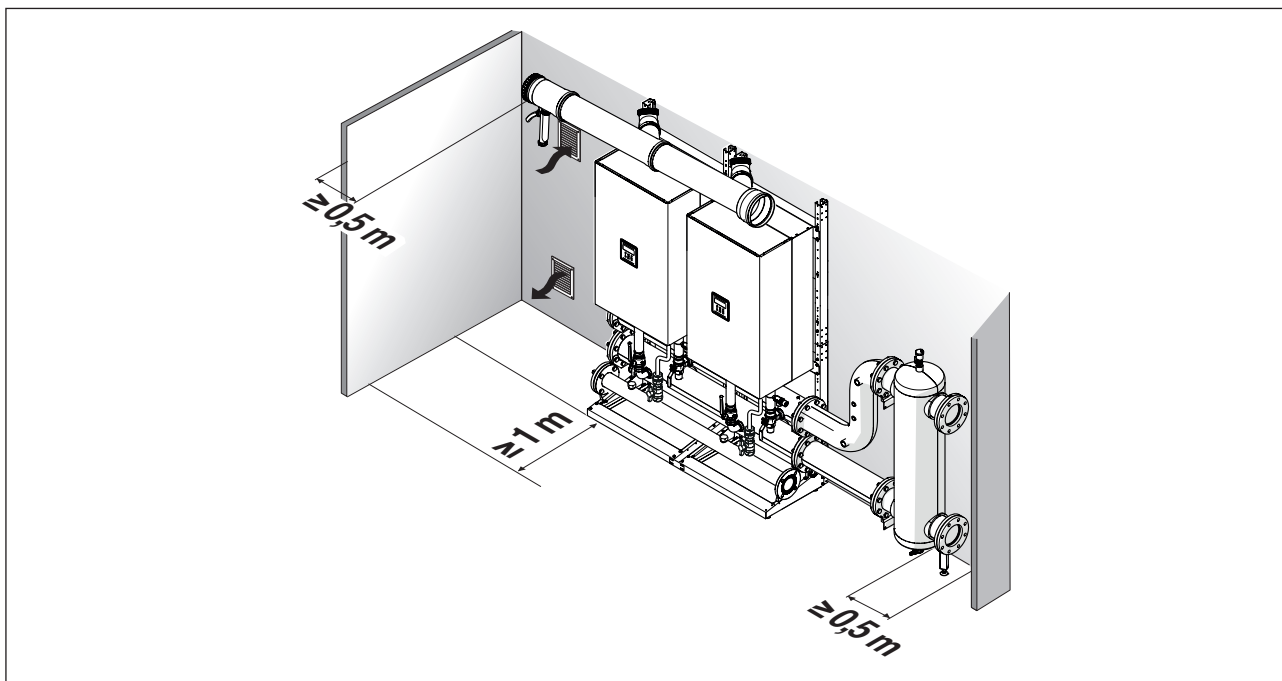

Space required for back-to-back layout (B2B - BACK TO BACK)

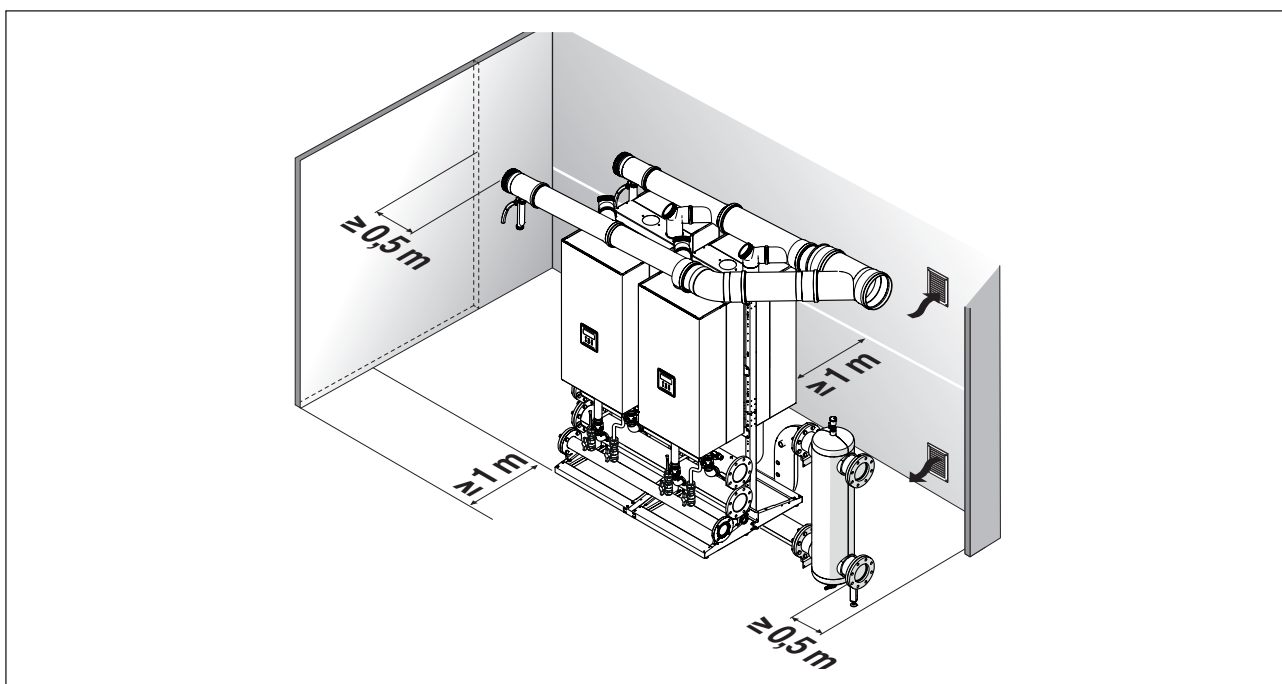

- ⚠ When installing the boiler, allow sufficient space around it to access all safety and control devices and to permit easy maintenance.
- ⚠ The height of the installation room must meet the fire-prevention requirements and current regulations in force in the country of installation.
- ⚠ Check that the electrical protection rating of the module is sufficient for the characteristics of the installation room.
- ⚠ If the modules are powered by combustible gas with a specific weight exceeding that of air, the electrical parts must be positioned at a height exceeding 500 mm from the ground.

1.5 Air vent

The rooms must be equipped with one or more permanent air vents positioned on external walls, ensuring that the all regulations established in the country of installation are complied with.

For Italy:

The air vents must not have a surface area less than the minimum value indicated in the table (expressed in cm²):

Rooms above the ground

(*) 5000 cm² in the case of G30-G31

Model	POWER MAX					
	65 P	80 P	100	110	130	150
No. of Boilers	MINIMUM DIMENSION OF AIR VENT (cm ²)					
2	3000*	3000*	3000*	3000*	3000*	3000*
3	3000*	3000*	3000*	3000*	3360*	3930*
4	3000*	3000*	3600*	3880*	4480*	5240
5	3000*	3400*	4500*	4850*	5600	6550
6	3420*	4080*	5400	5820	6720	7860
7	3990*	4760*	6300	6790	7840	9170
8	4560*	5440	7200	7760	8960	10480
9	5130	6120	8100	8730	10080	ND
10	5700	6800	9000	9700	11200	ND

Rooms below ground, down to a distance of - 5 m from the reference floor level:

Model	POWER MAX					
	65 P	80 P	100	110	130	150
No. of Boilers	MINIMUM DIMENSION OF AIR VENT (cm ²)					
2	3000	3000	3000	3000	3360	3930
3	3000	3060	4050	4365	5040	5895
4	3420	4080	5400	5820	6720	7860
5	4275	5100	6750	7275	8400	9825
6	5130	6120	8100	8730	10080	11790
7	5985	7140	9450	10185	11760	13755
8	6840	8160	10800	11640	13440	15720
9	7695	9180	12150	13095	15120	ND
10	8550	10200	13500	14550	16800	ND

Rooms below ground, at a distance of between - 5 m and - 10 m below the reference floor level (with a minimum of 5000 cm²):

Model	POWER MAX					
	65 P	80 P	100	110	130	150
No. of Boilers	MINIMUM DIMENSION OF AIR VENT (cm ²)					
2	5000	5000	5000	5000	5000	5240
3	5000	5000	5400	5820	6720	7860
4	5000	5440	7200	7760	8960	10480
5	5700	6800	9000	9700	11200	13100
6	6840	8160	10800	11640	13440	15720
7	7980	9520	12600	13580	15680	18340
8	9120	10880	14400	15520	17920	20960
9	10260	12240	16200	17460	20160	ND
10	11400	13600	18000	19400	22400	ND



It is not permitted to install systems for relative gas density greater than 0.8 (G30-G31) in rooms with flooring below the natural ground level.



The aeration surface area must not in any case be less than 3000 cm² or 5000 cm² if using gas with a density exceeding 0.8 (G30-G31).





The air vents in rooms with appliances supplied with gas must meet all fire prevention requirements, in particular Ministerial Decree of 12th April 2011 and subsequent updates.

2.2 Assembly of the FRAMES

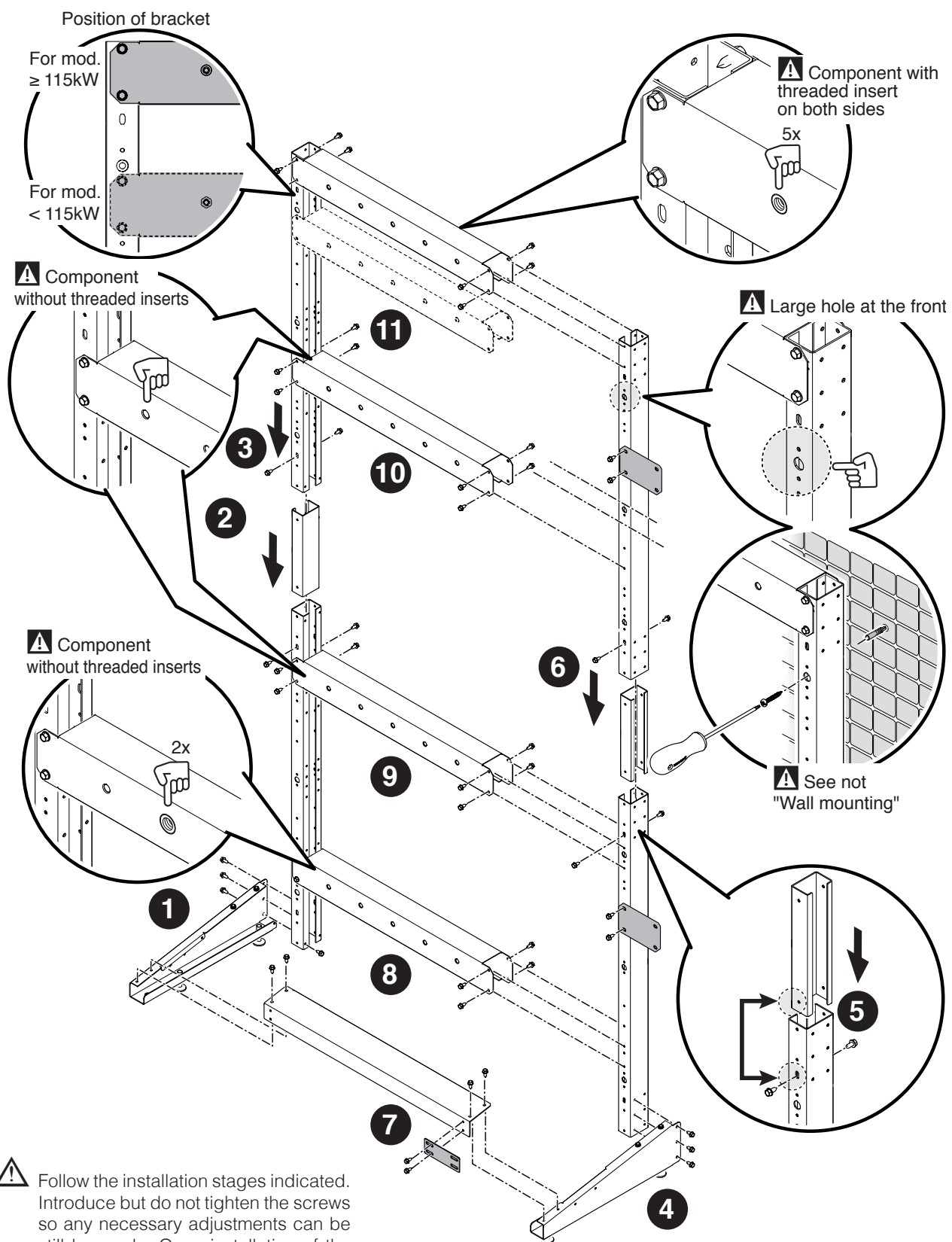
Assembly of the cascade frame in-line. Components included in code 20131663

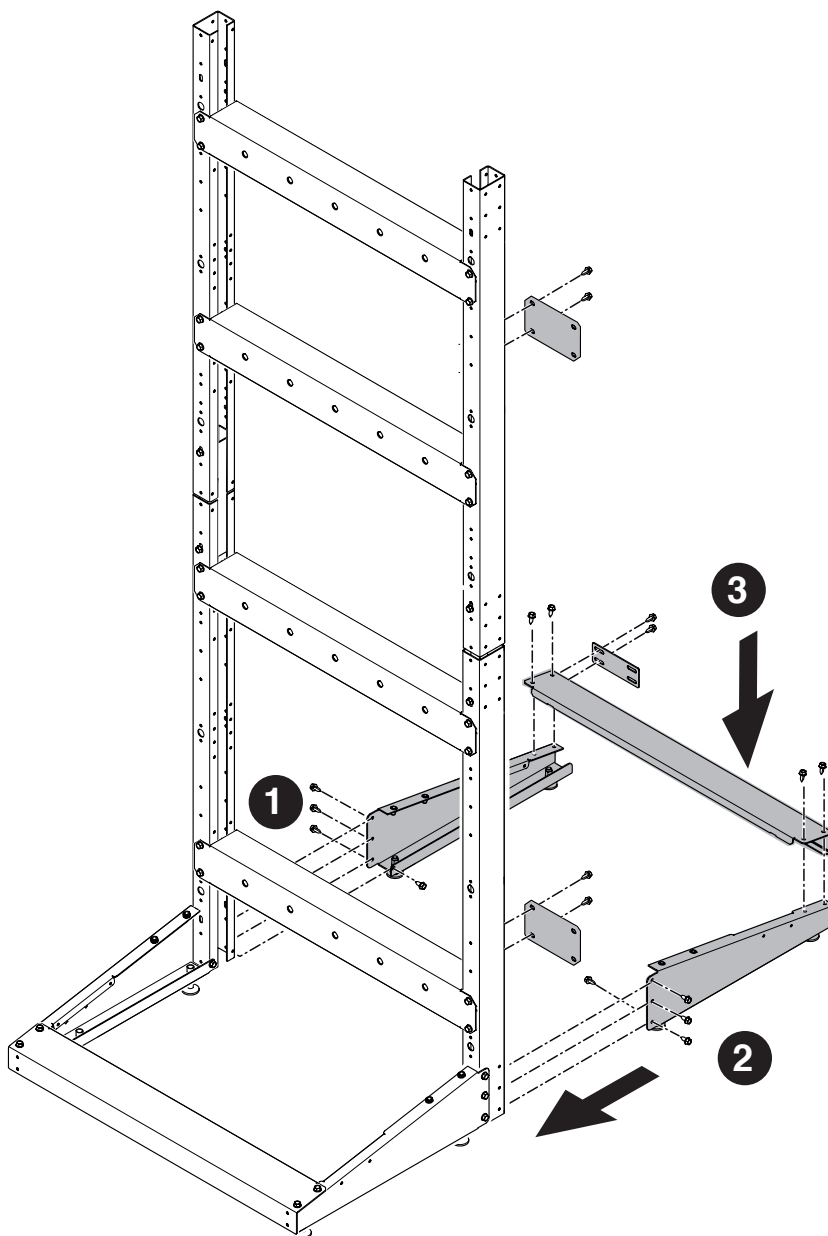



 Follow the installation stages indicated. Introduce but do not tighten the screws so any necessary adjustments can be still be made. Once installation of the entire frame has been completed, only then can the screws be fully tightened.

Fastening the frames to each other.

Cascade installation in-line

Cascade installation B2B

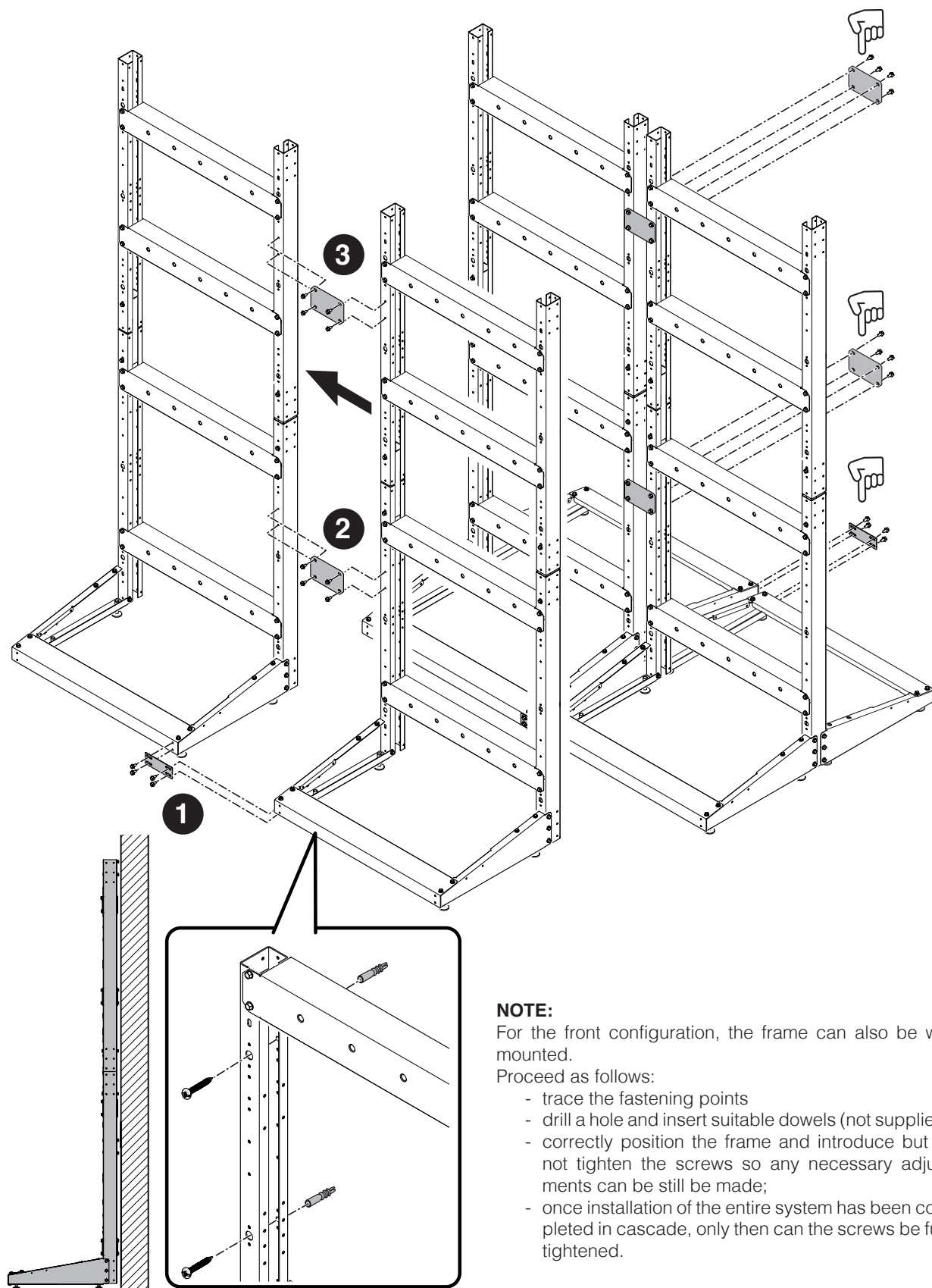

NOTE:

For the front configuration, the frame can also be wall mounted.

Proceed as follows:

- trace the fastening points
- drill a hole and insert suitable dowels (not supplied);
- correctly position the frame and introduce but do not tighten the screws so any necessary adjustments can be still be made;
- once installation of the entire system has been completed in cascade, only then can the screws be fully tightened.

Adjusting the feet

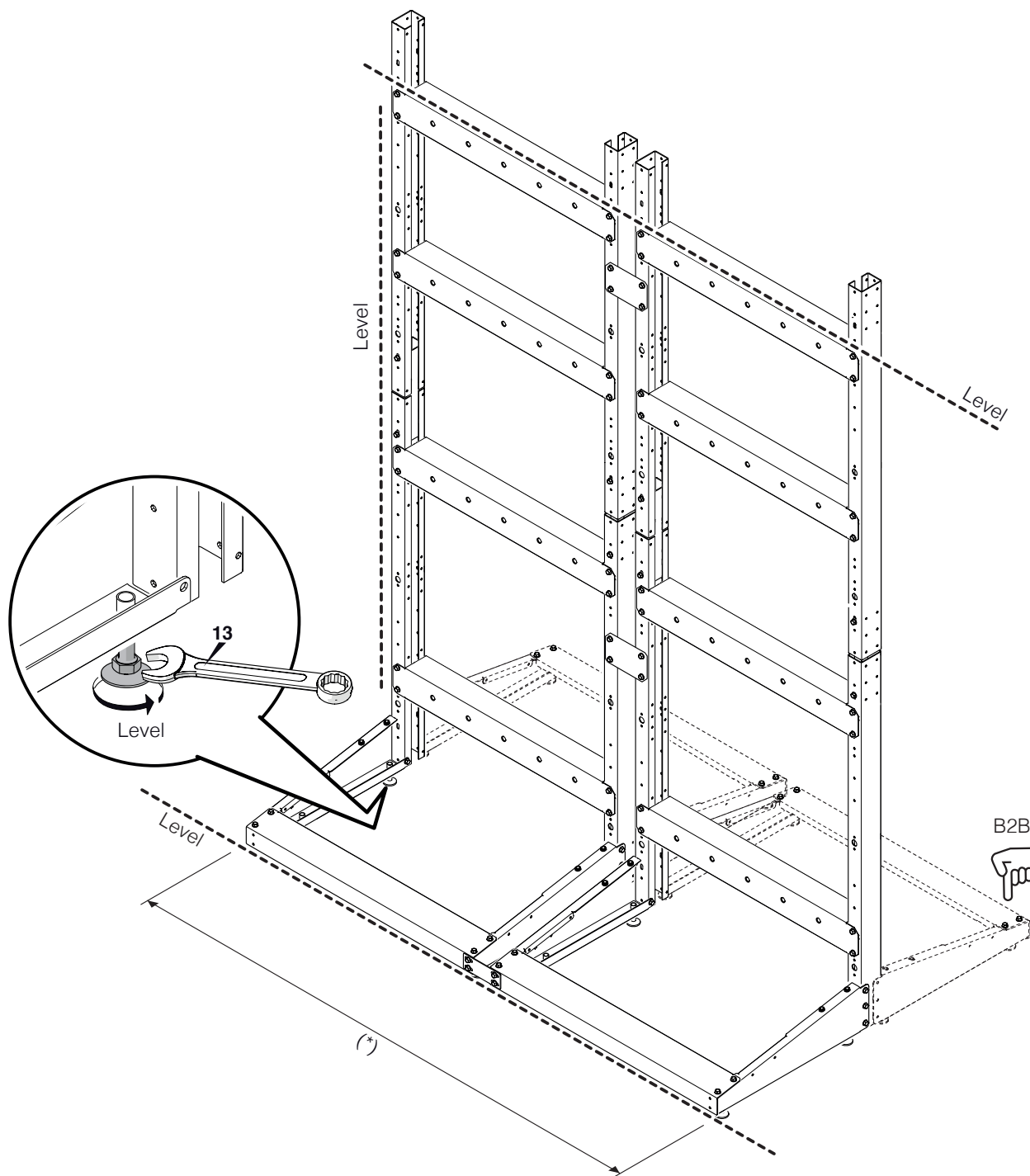

(*) check the measurements on the table of the dimensions present in the paragraph "System layout".

Moving and removing the packing

- ⚠ Do not remove the cardboard used for packaging the appliance until it has reached the place of installation.
- ⚠ Before carrying out any transport operations or removing the packaging, ensure you are wearing suitable PPE and use tools and means which are appropriate for the dimensions and weight of the appliance.
- ⚠ This operations is to be carried out by more than one person, equipped with means which are suitably for the weight and dimensions of the appliance. Make sure that the weight of the package remains balanced during handling operations.

Proceed as follows to remove the packing:

- Remove the retainers which secure the package to the pallet
- Remove the cardboard
- Remove edge protectors (1)
- Remove the Styrofoam protection (2)
- Remove the protective bag (3).

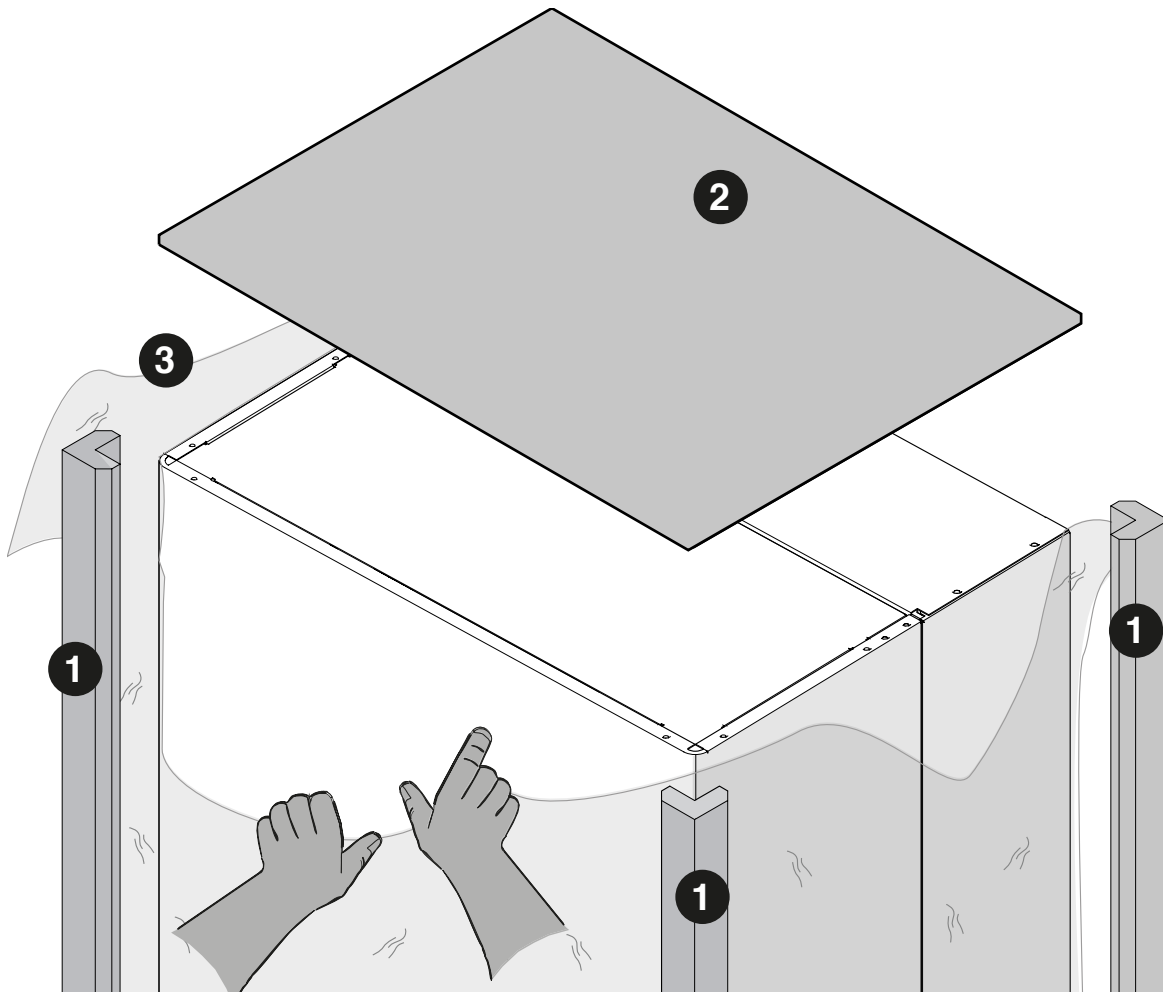

Fitting the module support bracket

The bracket is supplied together with the module.

Cascade installation B2B

Cascade installation in-line

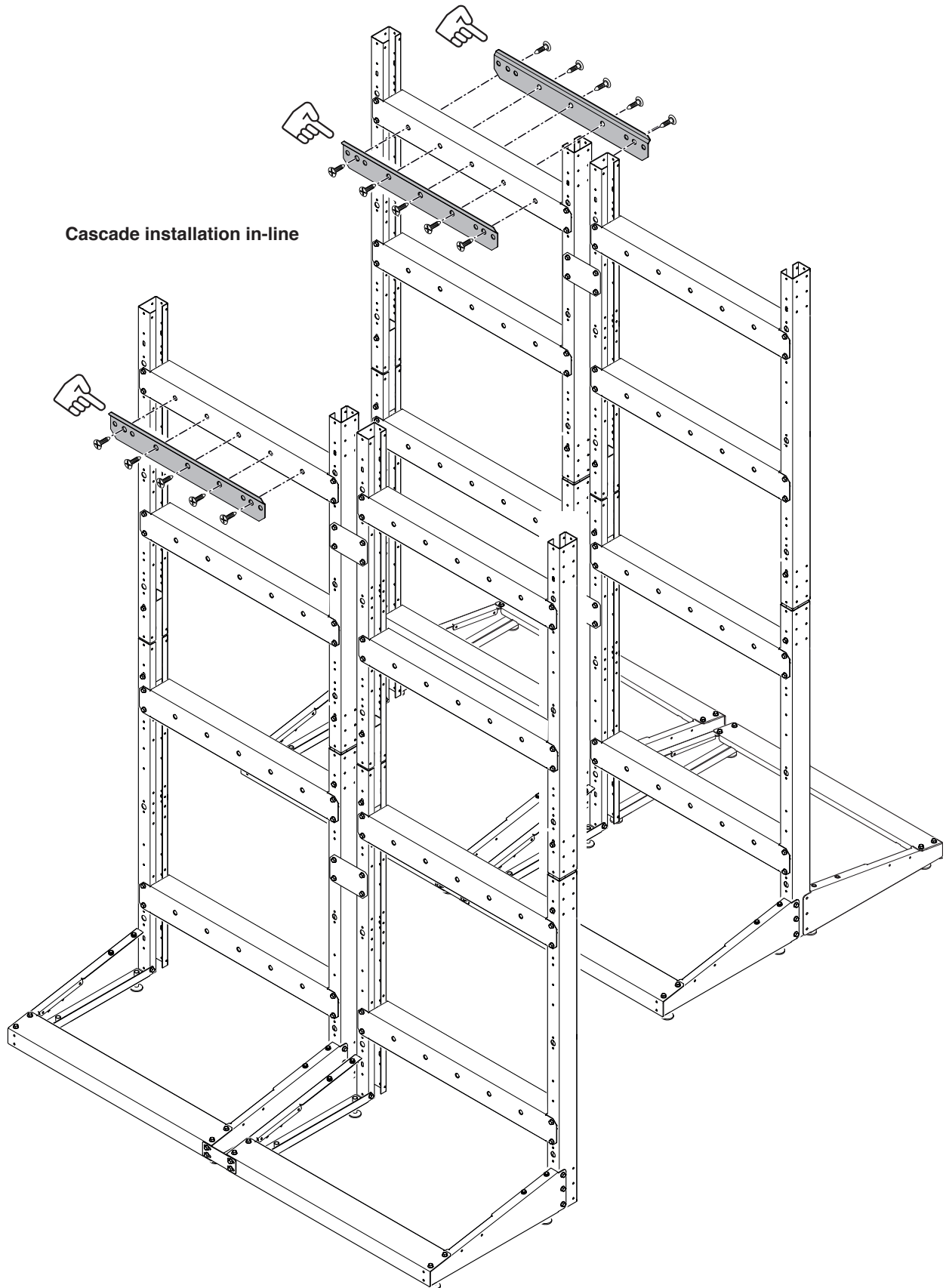

Fitting the module onto the frame

- 1 Working together with other people, lift the module.
- 2 Correctly position the module on the bracket which was previously fitted onto the frame.

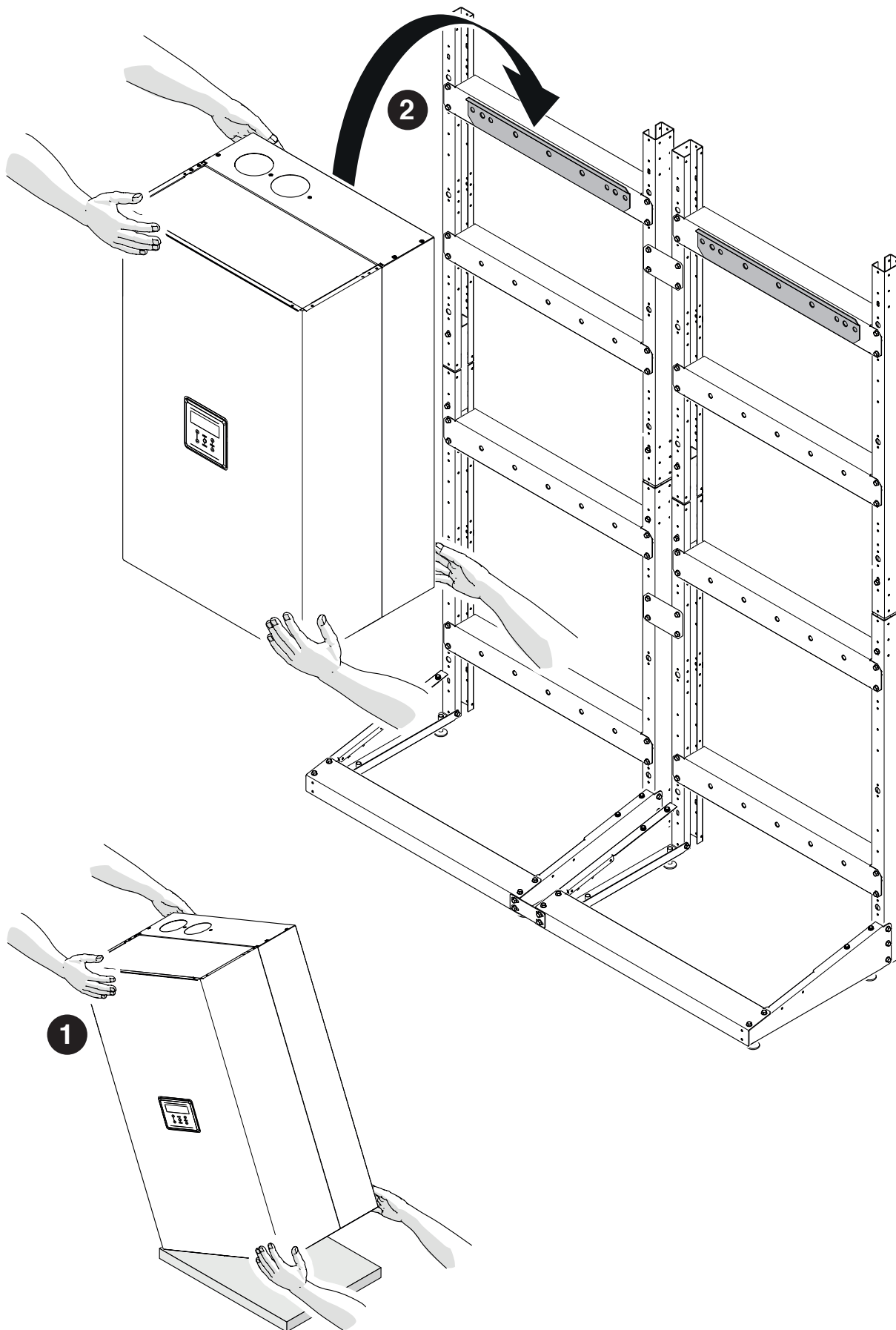

Removing the front panels

- 1 Remove the lock screw (A) and pull the front panel outwards.
- 2 Push the front panel upwards to release it from the points (B).

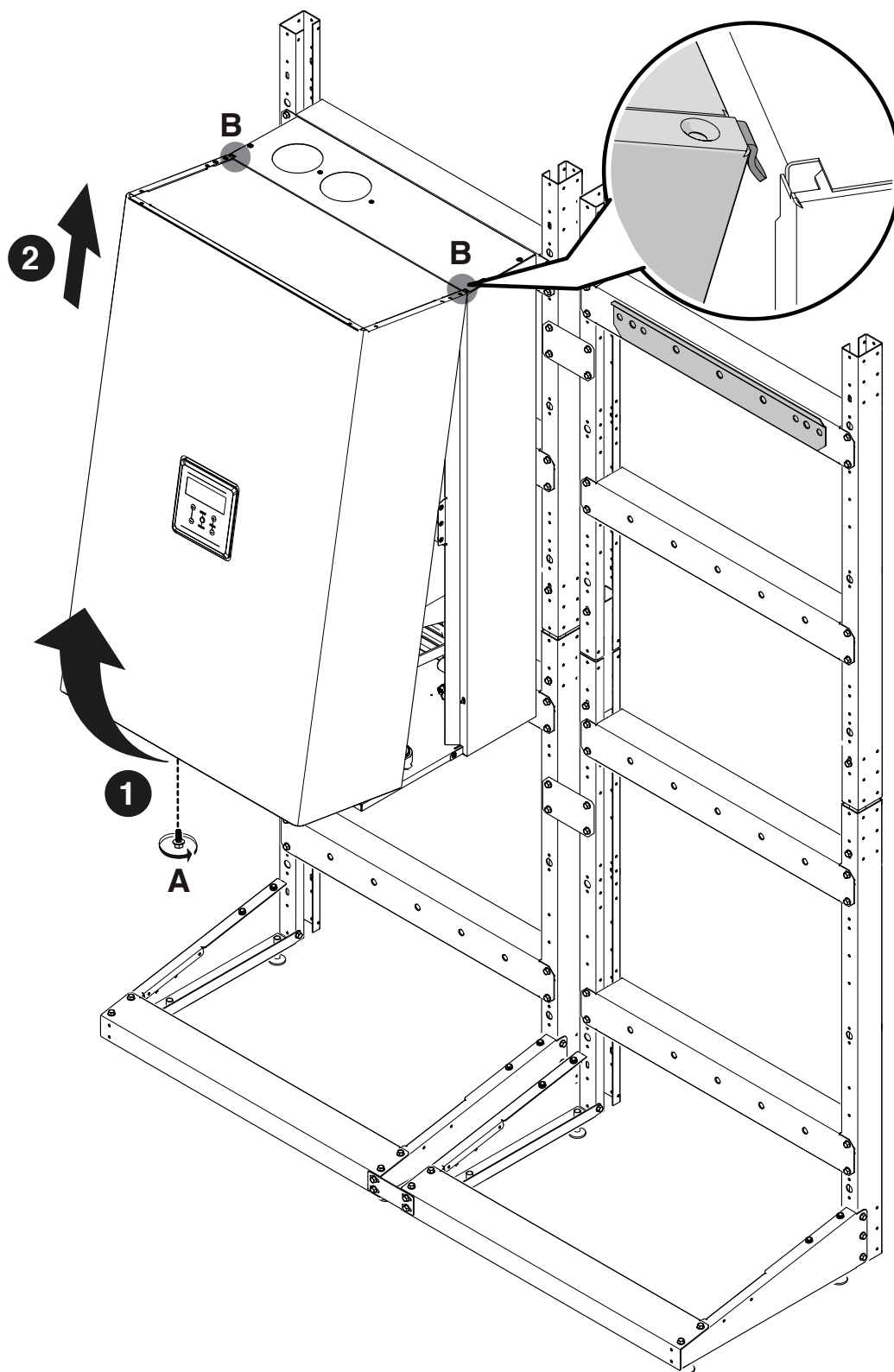

To fit the front cover, see Chapter "Commissioning and maintenance".

2.3 Positioning the CONDENSATE PIPES

Installation of the condensate outlet pipe. Components included in code 20130222 - 20130223

The figure refers to an installation with 2 modules in line or 3/4 modules B2B.

- 1 Position the seal on the side of the condensate outlet.
- 2 Position the plug on the opposite side of the condensate outlet.

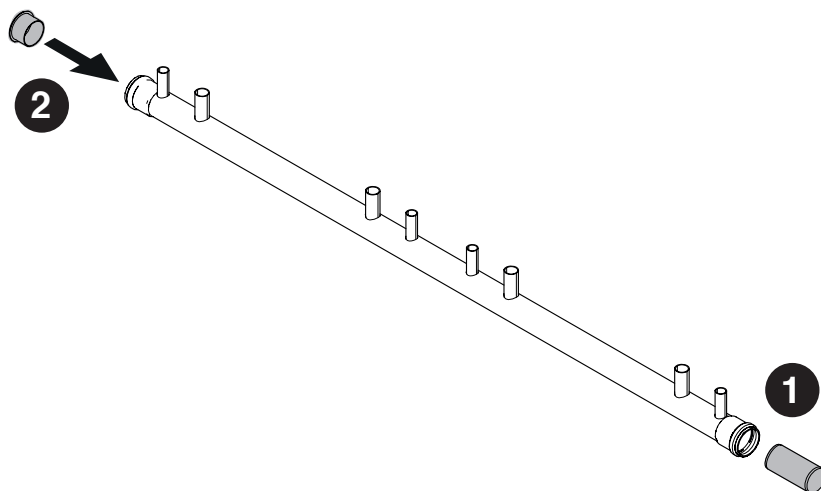

- 3 Position the condensate outlet pipe on the frames.
- 4 Secure it using the designated brackets.

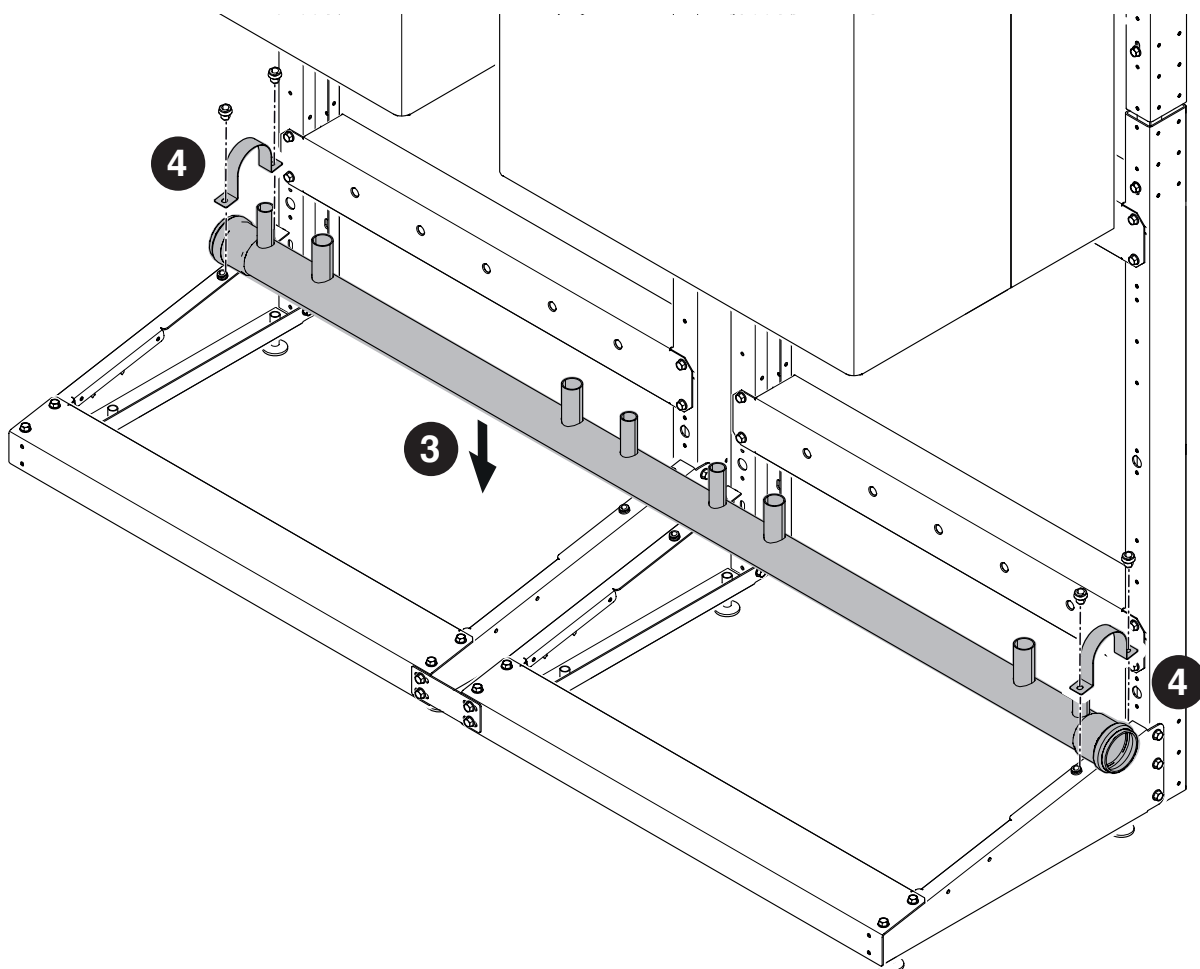

2.4 Positioning the 3" MANIFOLDS

Assembly of the gas, delivery and return manifolds. Components included in code 20133220 - 20130220 - 20130221

The figure refers to an installation with 2 modules in line or 3/4 modules B2B.

- 1 Secure the left support bracket.
- 2 Secure the right support bracket.
- 3 Position the RETURN manifold.

 Make sure that the delivery and return manifolds are not inverted.

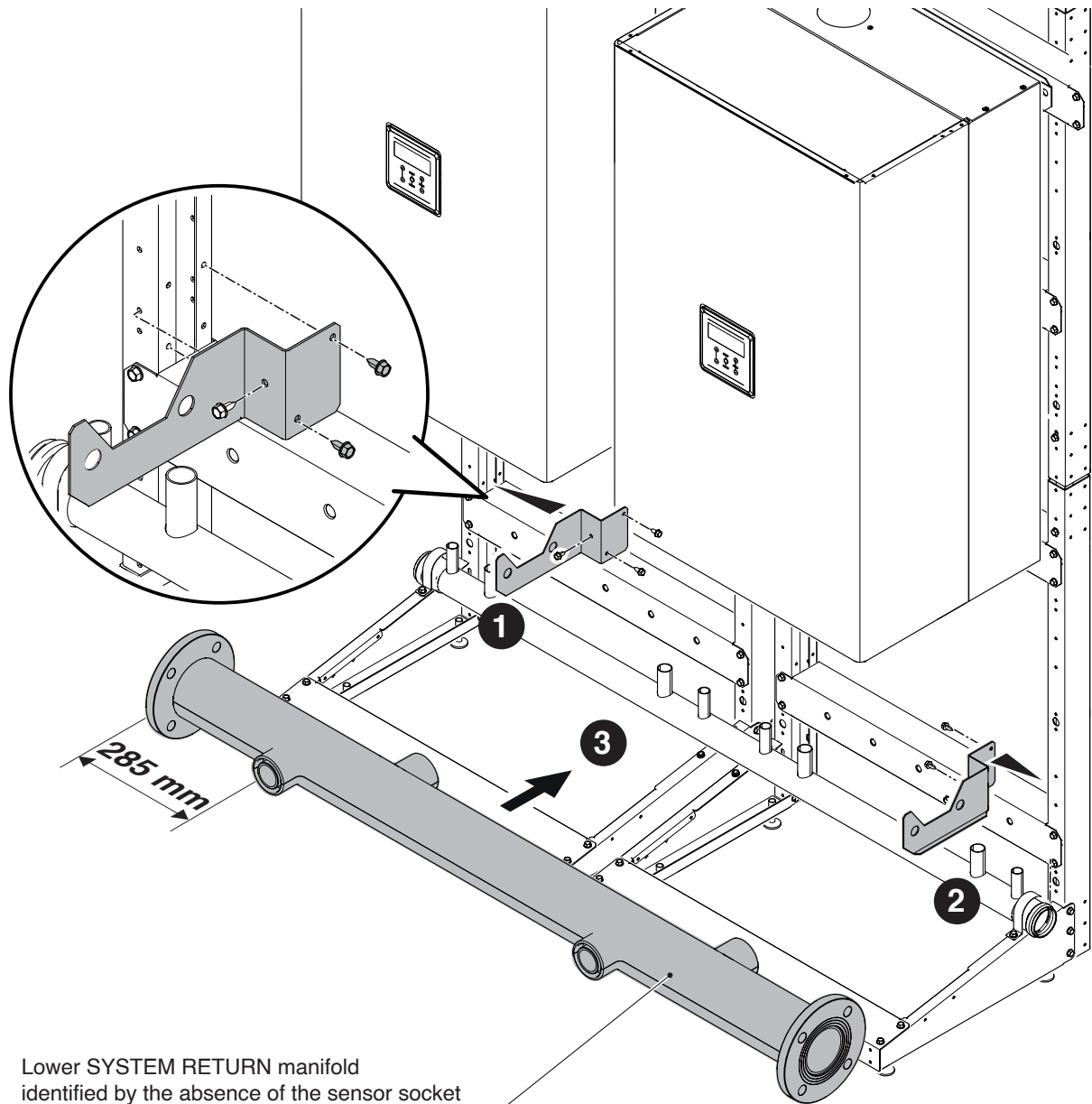

- 4 Secure the left support bracket.
- 5 Secure the right support bracket.
- 6 Position the DELIVERY manifold.

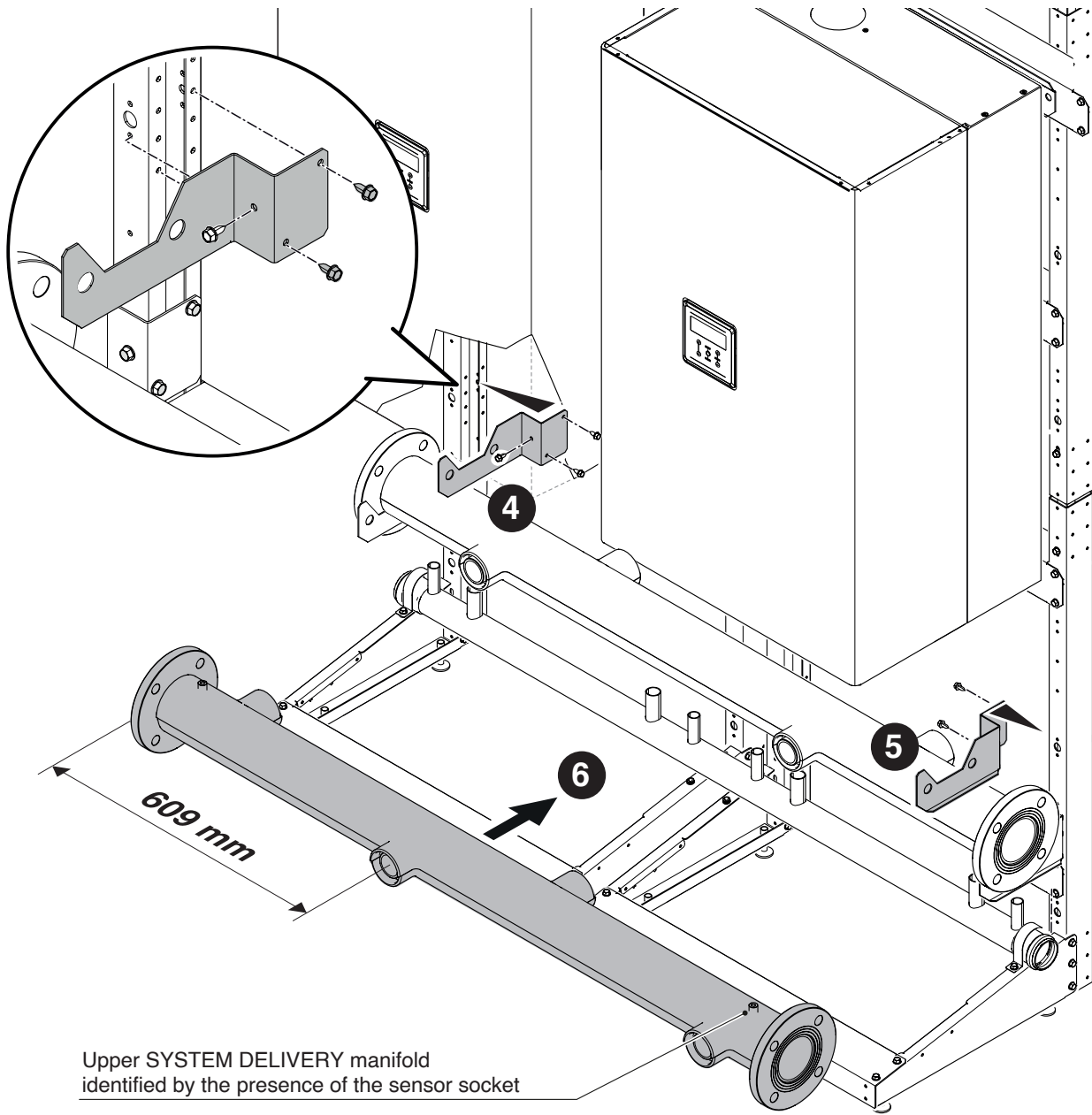

Upper SYSTEM DELIVERY manifold
identified by the presence of the sensor socket

- 7 Position the GAS manifold.
- 8 Secure the GAS manifold to the frame.

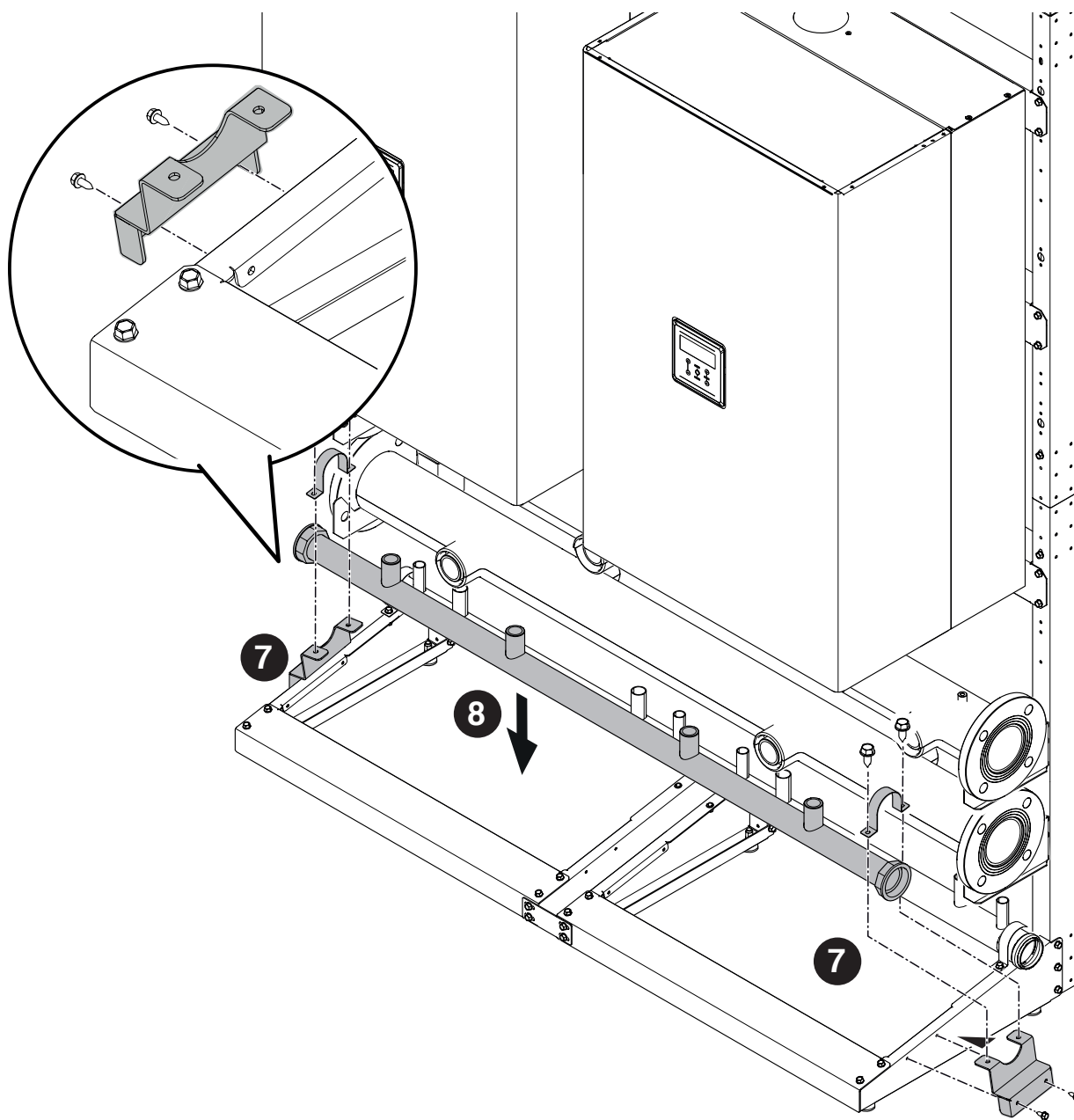

9 Position the manifold closing plugs from the required side.

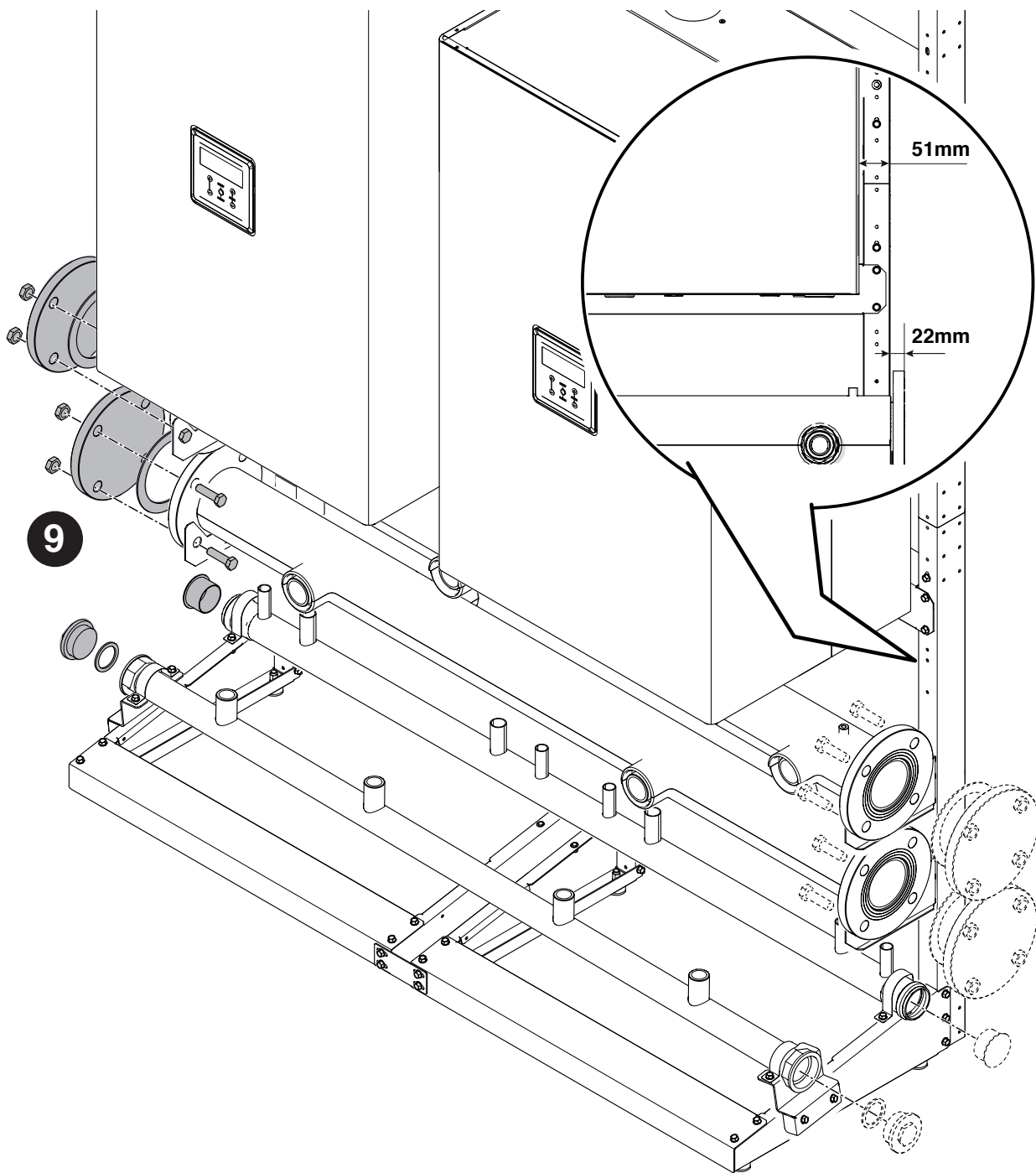

2.5 Positioning the 5" MANIFOLDS

Assembly of the gas, delivery and return manifolds. Components included in code 20130222 - 20130223

The figure refers to an installation with 2 modules in line or 3/4 modules B2B.

- 1 Secure the left support bracket.
- 2 Secure the right support bracket.
- 3 Position the RETURN manifold.

 Make sure that the delivery and return manifolds are not inverted.

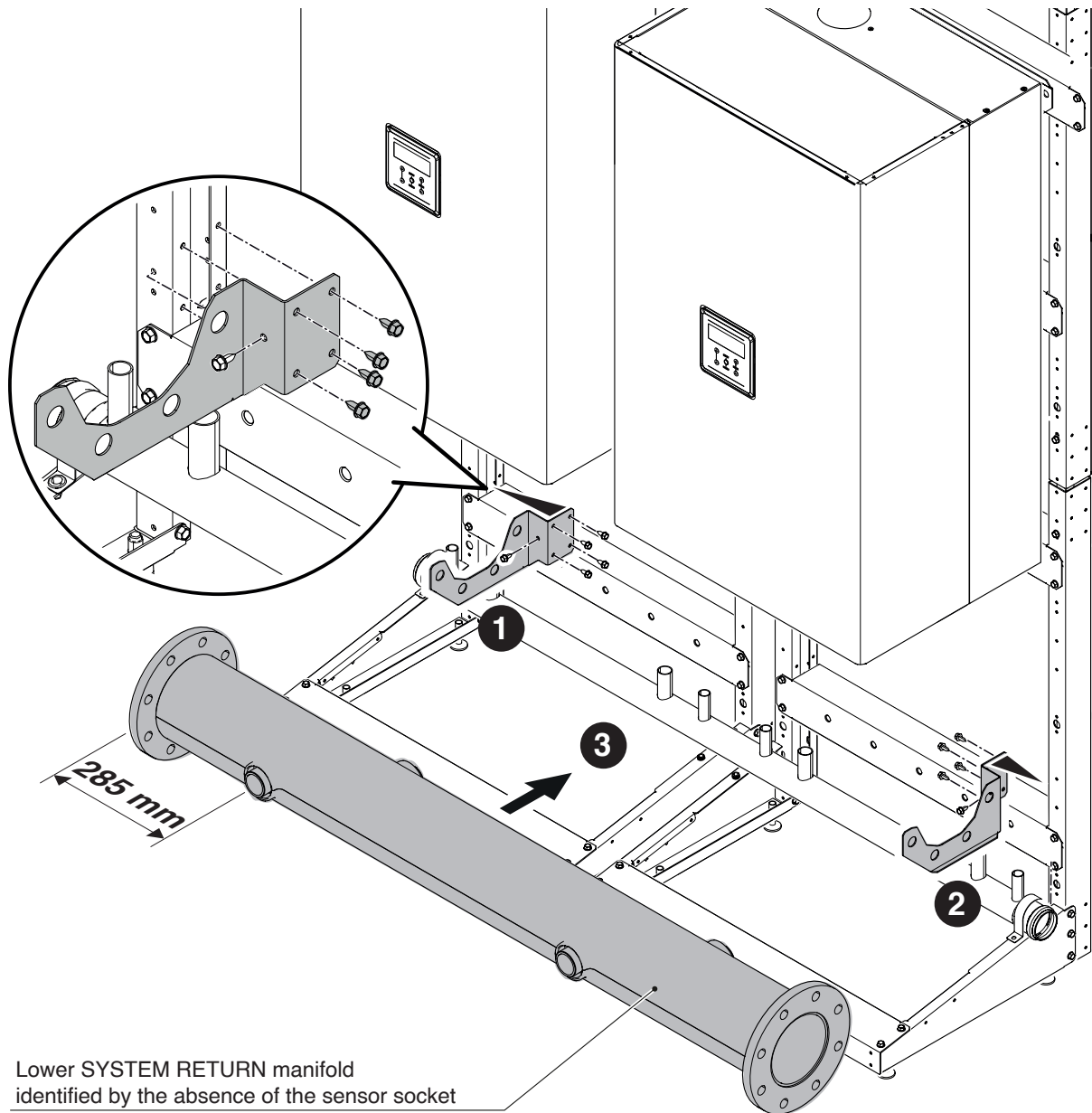

- 4 Secure the left support bracket.
- 5 Secure the right support bracket.
- 6 Position the DELIVERY manifold.

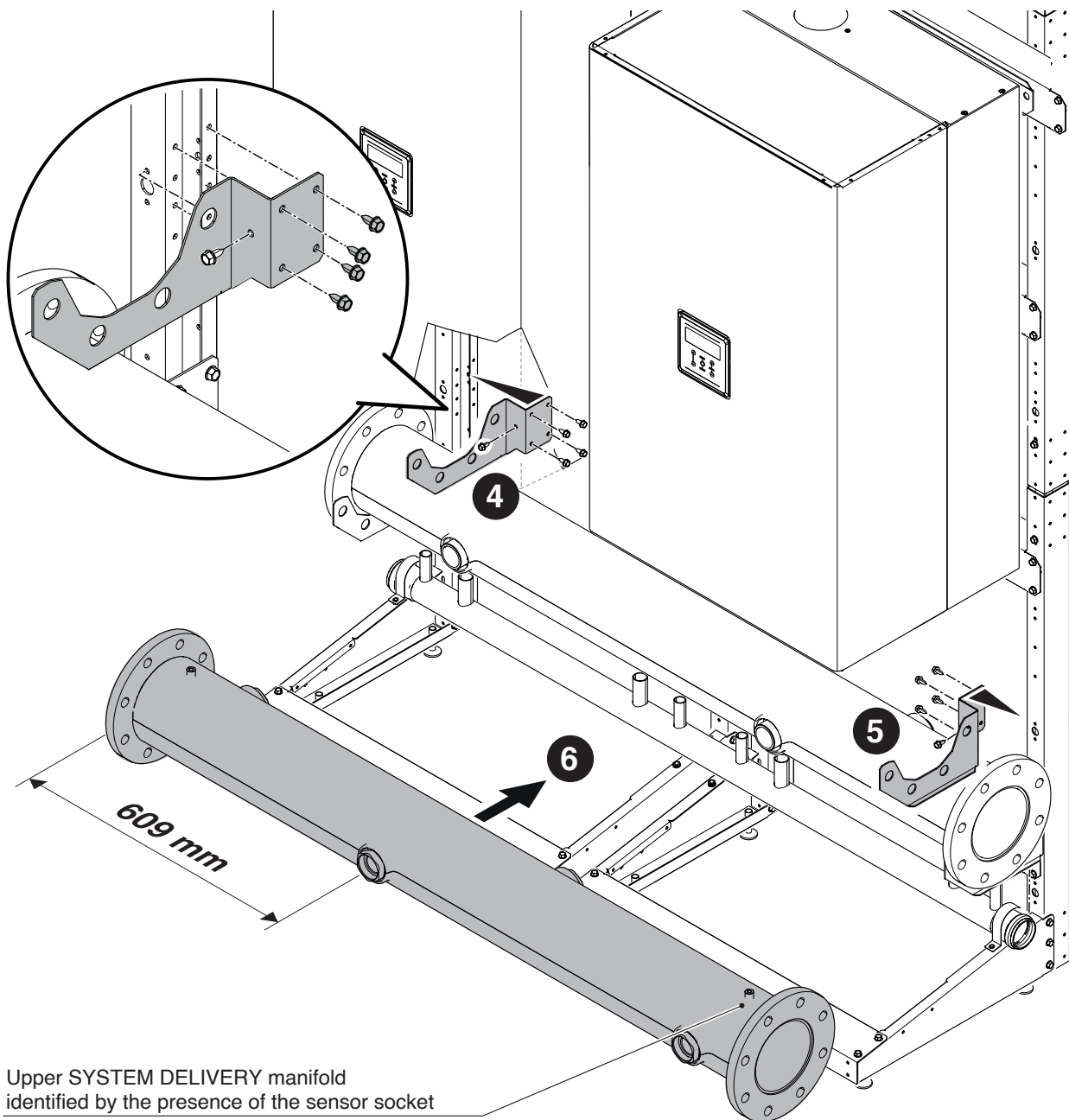

Upper SYSTEM DELIVERY manifold
identified by the presence of the sensor socket

- 7 Position the GAS manifold.
- 8 Secure the GAS manifold to the frame.

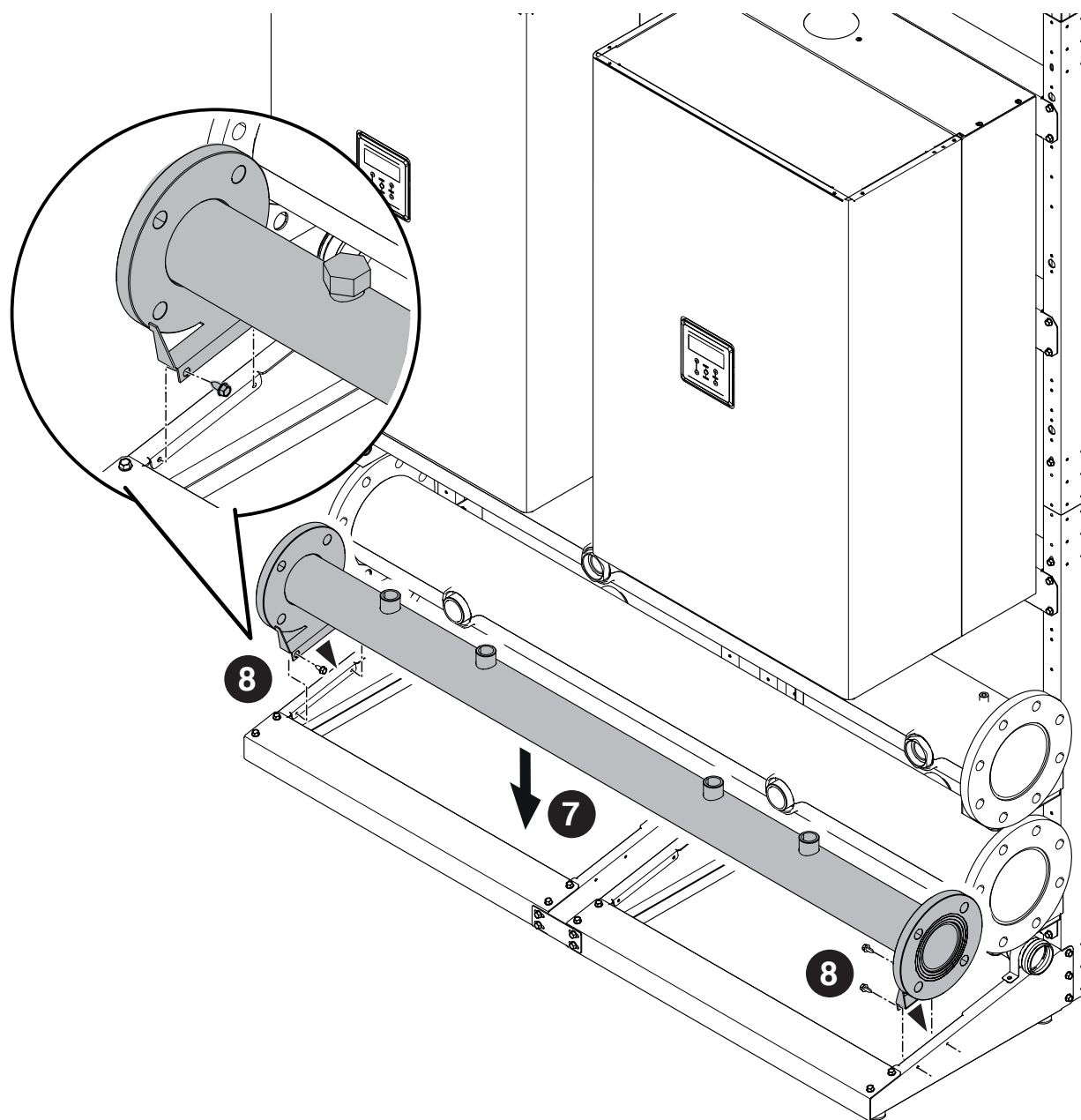

9 Position the manifold closing plugs from the required side.

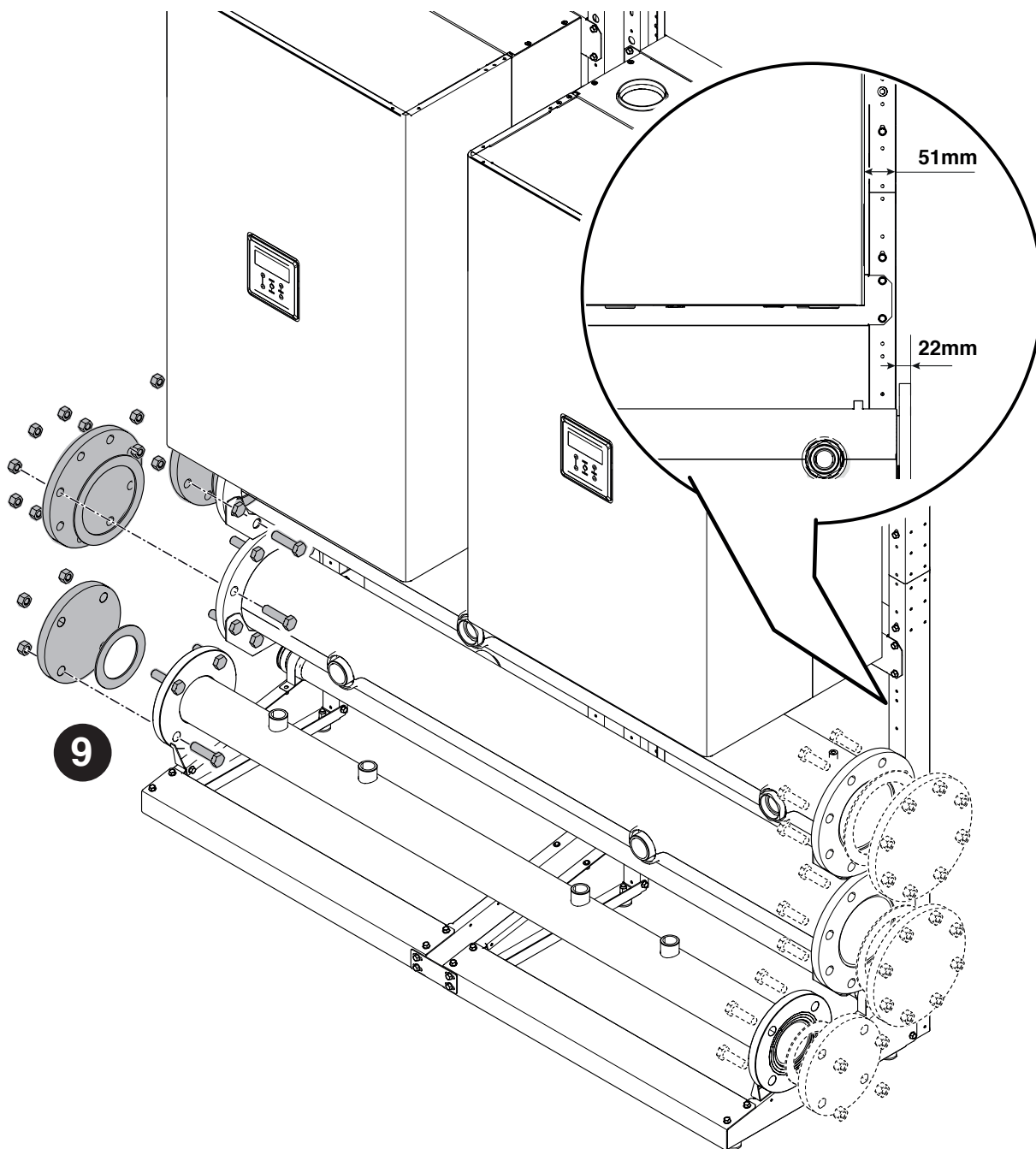

2.6 Positioning the CONDENSATE OUTLET

Assembly of the condensate outlet. Components included in code 20131267

The figure refers to an installation with 2 modules in line or 3/4 modules B2B.

- 1 Make a siphon using the outlet pipe and secure it using cable ties (not supplied).
- 2 Connect the pipes to the other modules working in the same way as described for the first.

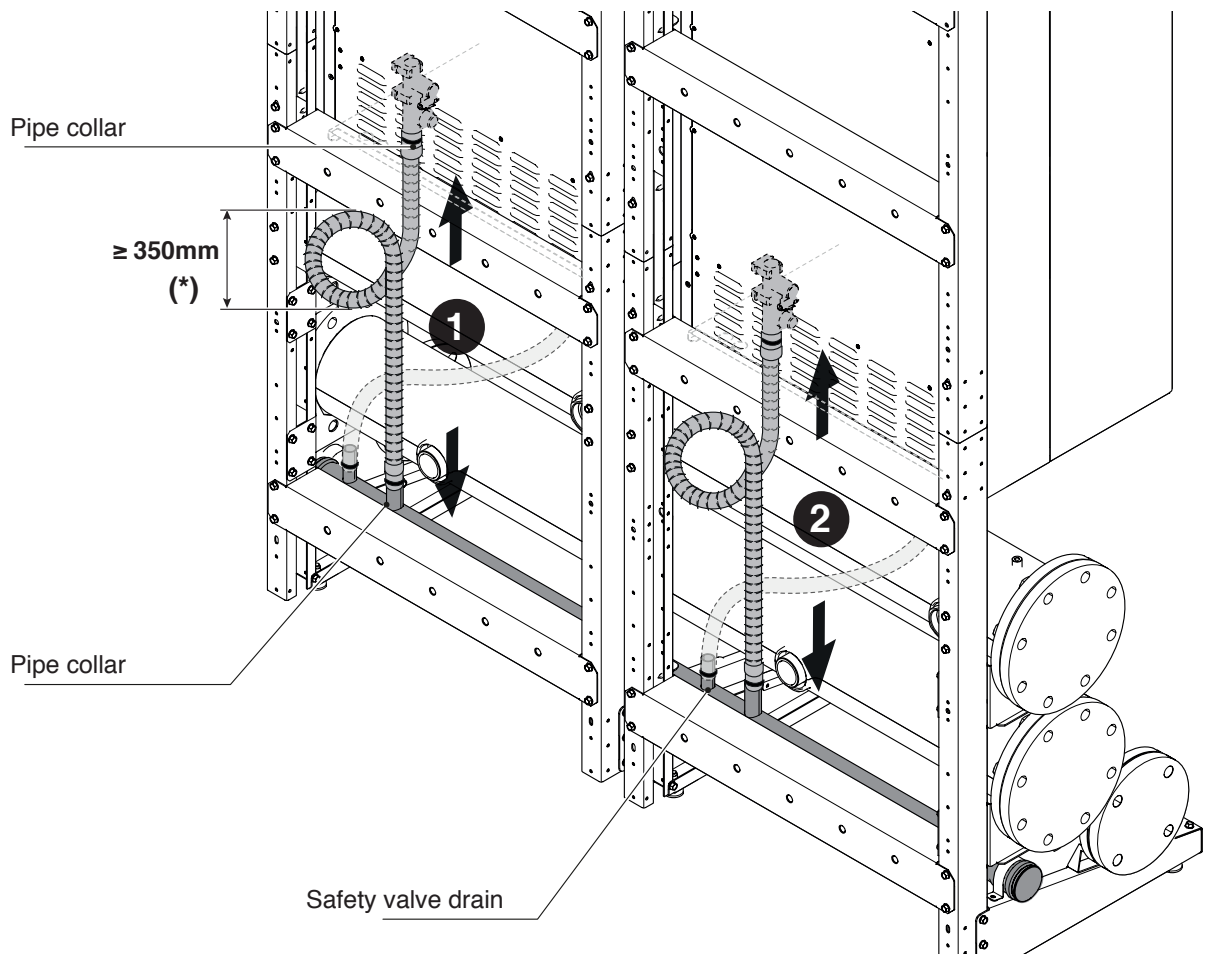

- ⚠ With modules in BACK TO BACK configuration, use the dedicated coupling points.
- ⚠ Correctly position the plugs on the coupling points which are not used.
- ⚠ The coupling points which are not used can be used for the relief valve outlet

2.7 Positioning the GAS PIPES

CASCADE CONFIGURATION IN-LINE

Assembly of the gas pipes. Components included in code 20130658 – 20131121 – 20131122 – 20131123 – 20131124 - 20131125.

- 1 Install and seal the gas pipe to the module.
- 2 Install and seal the cock to the pipe and the gas manifold.
- 3 Fit the plugs onto any unused coupling points ensuring tightness.

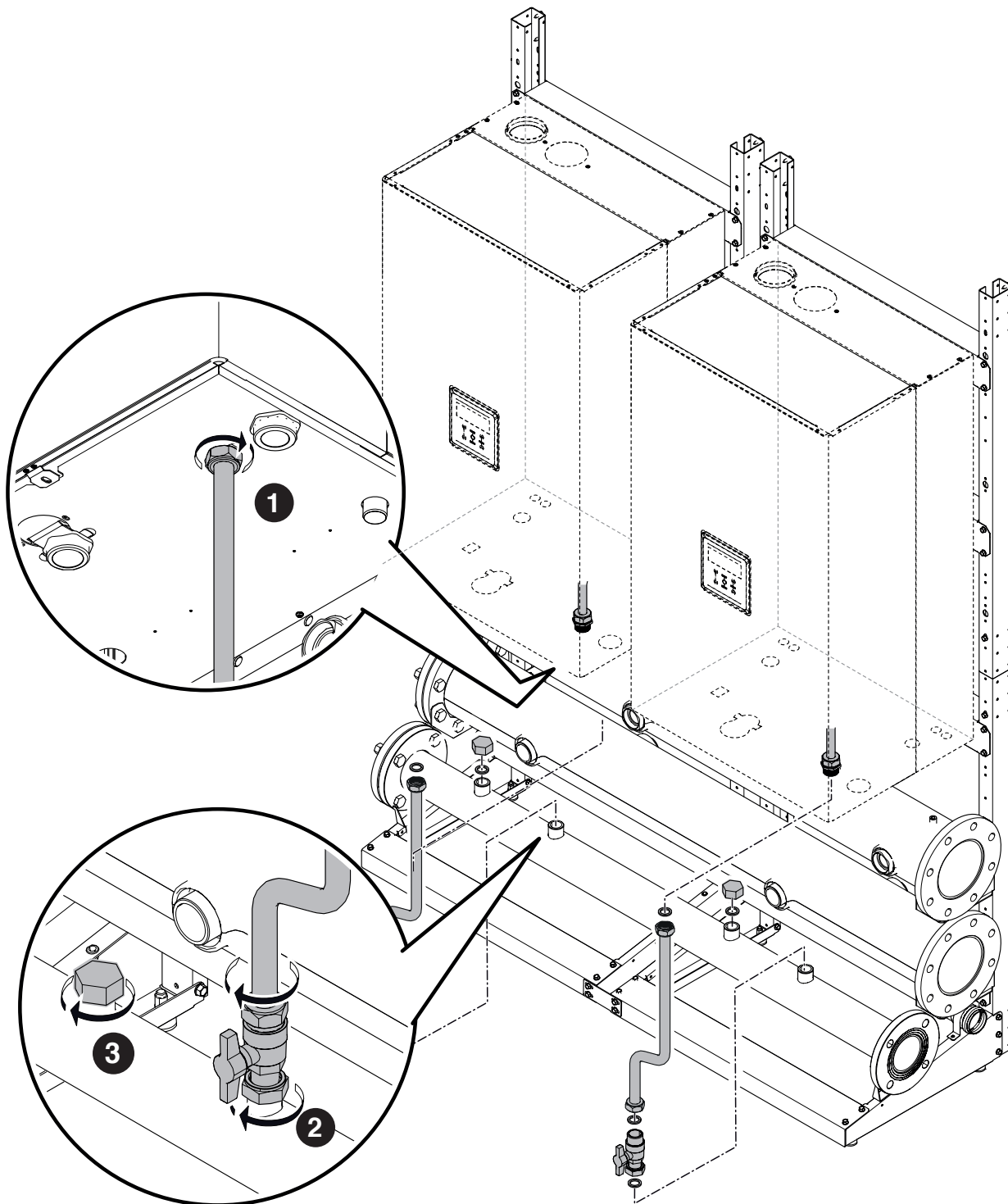

CASCADE CONFIGURATION B2B (BACK TO BACK)

Assembly of the gas pipes. Components included in code 20131787 – 20131788 – 20131789 – 20131790 – 20131791 – 20131792

- 1 Positioning the gas pipe.

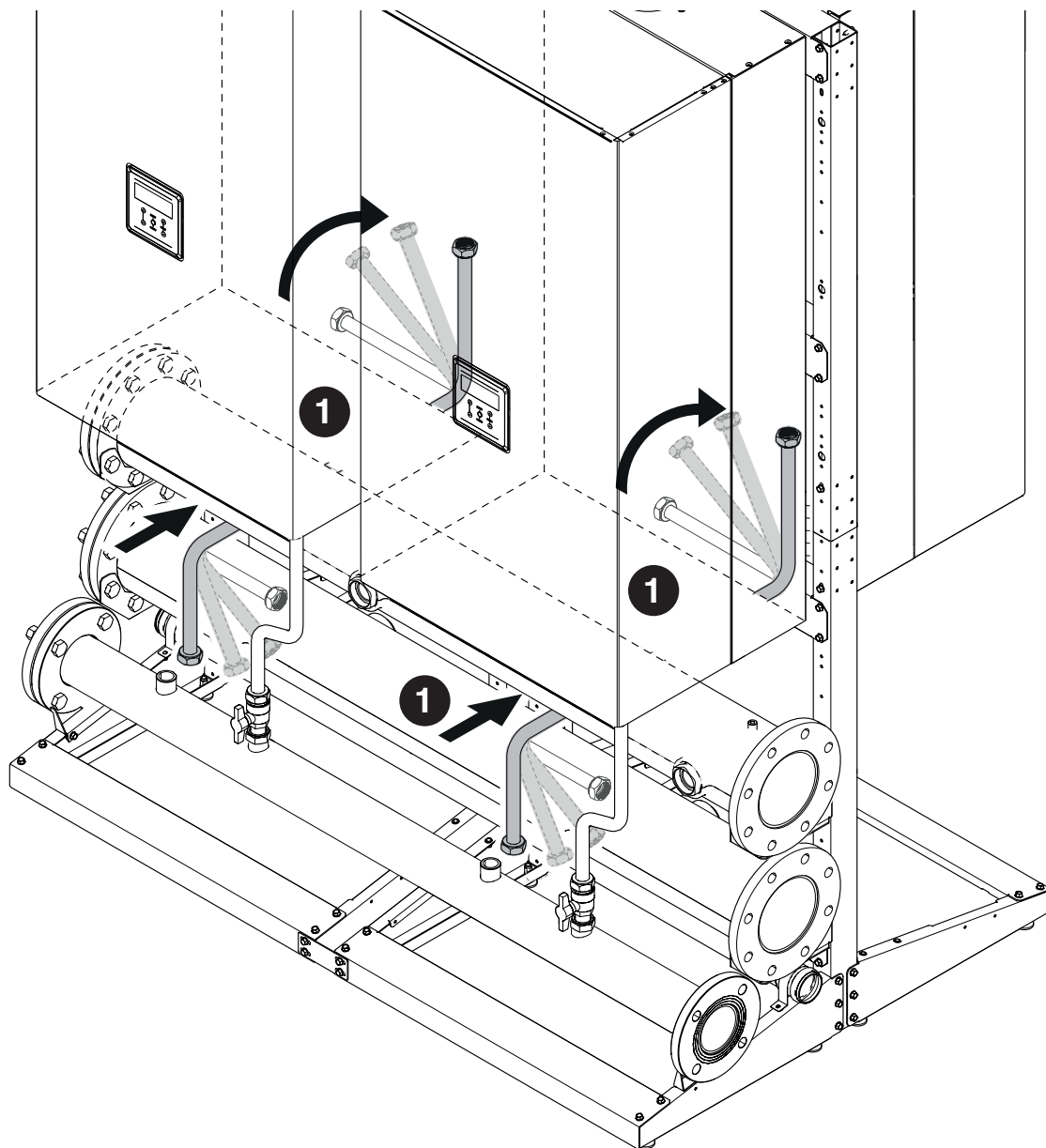

- 2 Installing and sealing the gas pipe to the module.
- 3 Install and seal the cock to the pipe and the gas manifold.

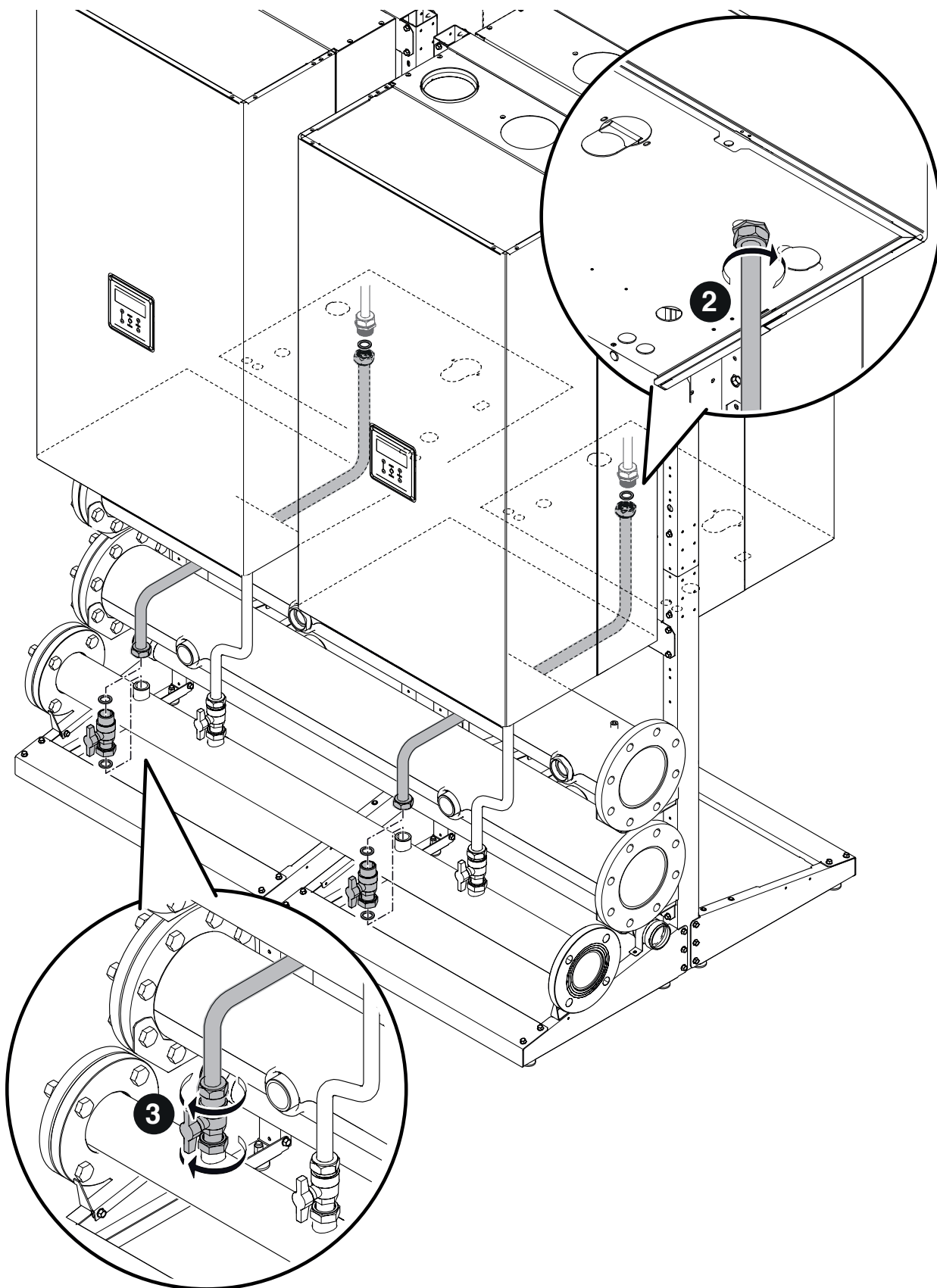



2.8 Positioning the DELIVERY-RETURN PIPES

CASCADE CONFIGURATION IN-LINE

Assembly of the RETURN pipes. Components included in code 20130658 – 20131121 – 20131122 – 20131123 – 20131124 - 20131125

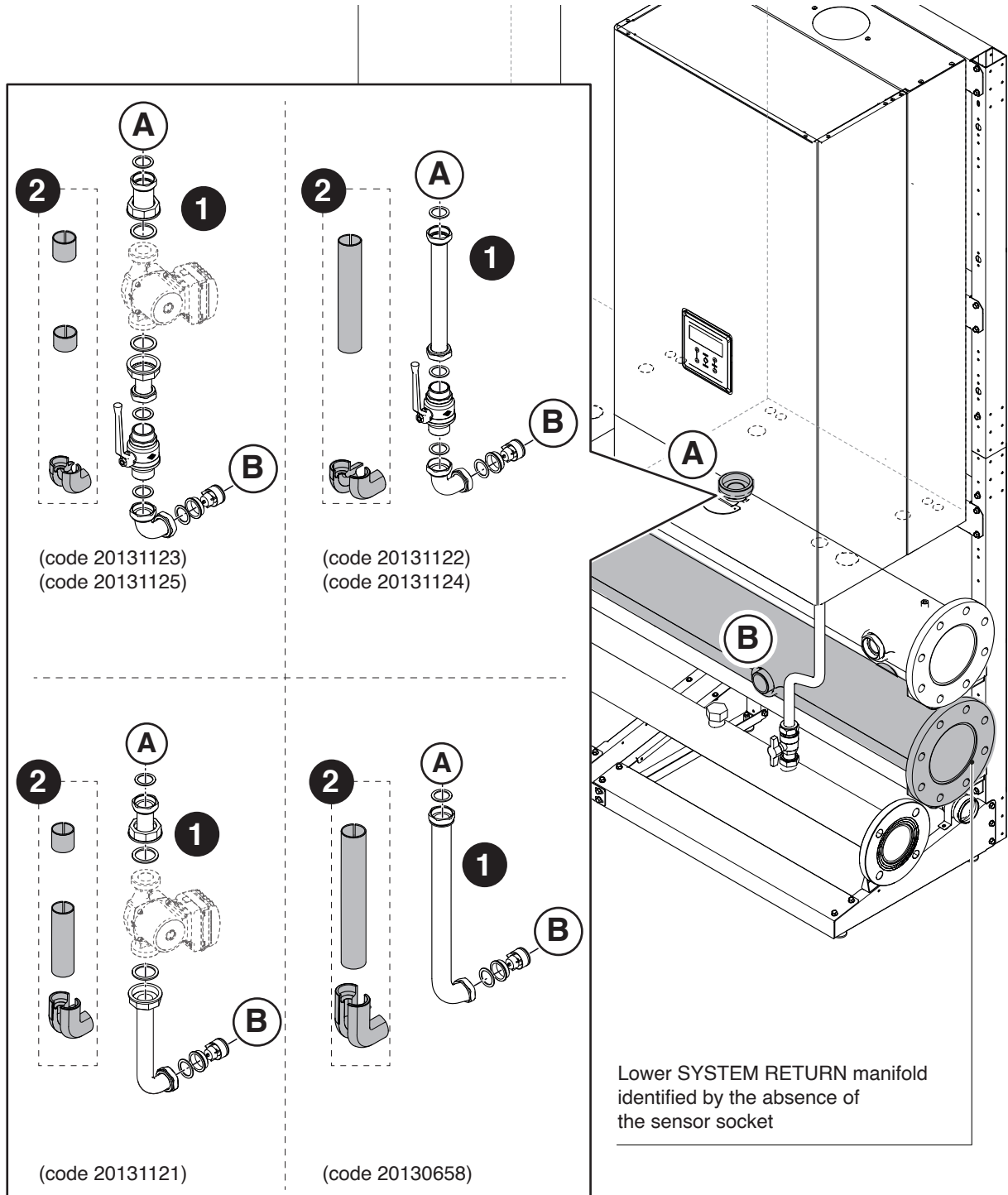
- 1 Install and seal the RETURN unit selected between the module coupling points (A) and (B) the return manifold.
- 2 Keep the insulation parts to one side and only fit them after testing has been completed.





 Secure the plugs onto any unused coupling points.

CASCADE CONFIGURATION IN-LINE

Assembly of the DELIVERY pipes. Components included in code 20130658 – 20131121 – 20131122 – 20131123 – 20131124 - 20131125

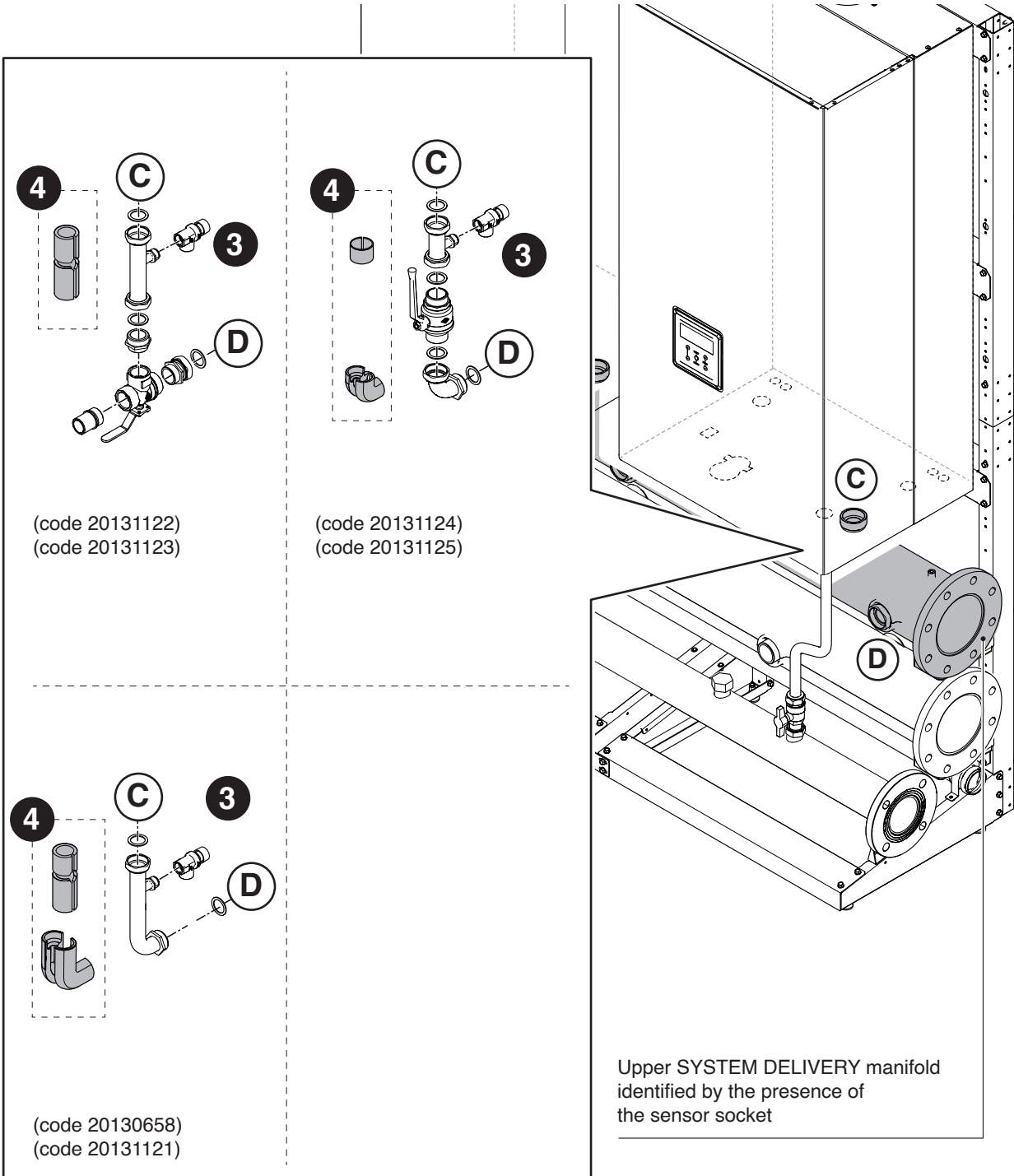
- 3 Install and seal the DELIVERY unit selected between the module coupling points (C) and (D) the return manifold.
- 4 Keep the insulation parts to one side and only fit them after testing has been completed.





 Secure the plugs onto any unused coupling points.

CASCADE CONFIGURATION B2B (BACK TO BACK)

Assembly of the RETURN pipes. Components included in code 20131787 – 20131788 – 20131789 – 20131790 – 20131791 - 20131792

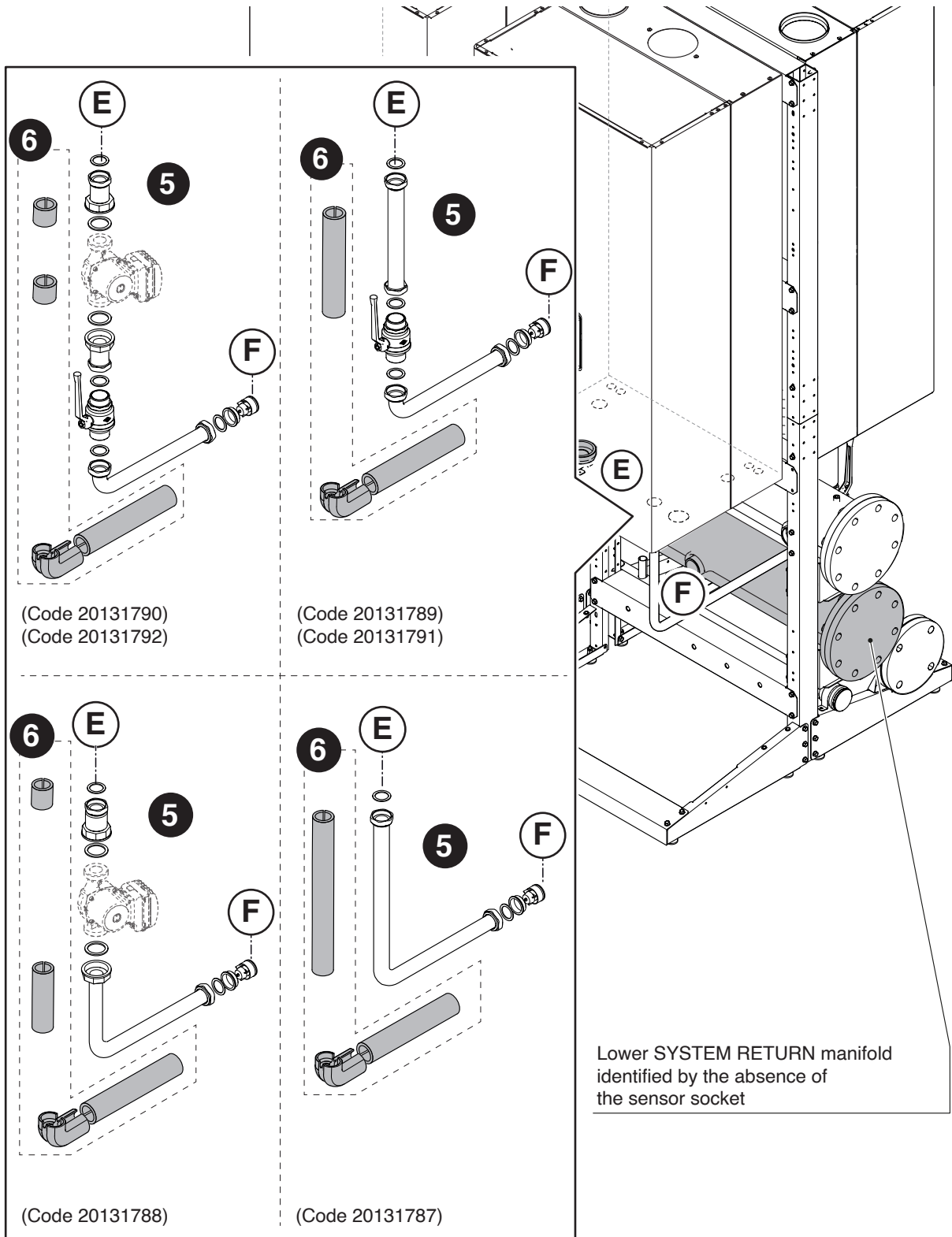
- 5 Install and seal the RETURN unit selected between the module coupling points (E) and (F) the return manifold.
- 6 Keep the insulation parts to one side and only fit them after testing has been completed.



 Secure the plugs onto any unused coupling points.

CASCADE CONFIGURATION B2B (BACK TO BACK)

Assembly of the DELIVERY pipes. Components included in code 20131787 – 20131788 – 20131789 – 20131790 – 20131791 - 20131792

- 7 Install and seal the DELIVERY unit selected between the module coupling points (G) and (H) the return manifold.
- 8 Keep the insulation parts to one side and only fit them after testing has been completed.

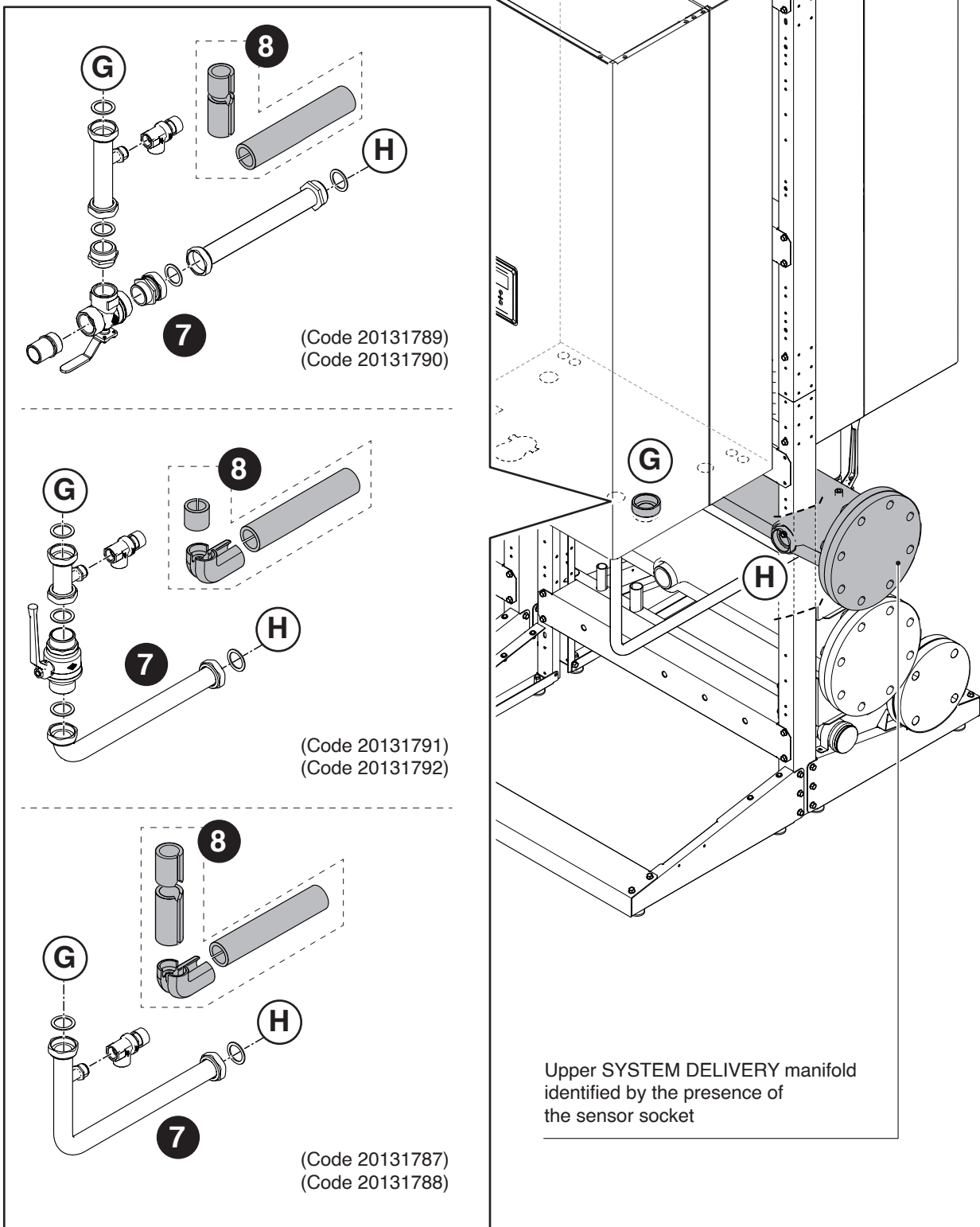

Secure the plugs onto any unused coupling points.

2.9 Positioning the SAFETY SECTION AND SEPARATOR

Assembly of the safety separator and separator. Components included in code 20070910 - 20070912 - 20132873 - 20070699 - 20070701 - 20070702 - 20132874 - 20070703 - 20070704 - 20070705 - 20071190 - 20023104 - 20023106 - 20009486 - 20009482 - 20009483 - 20061640

- 1 Install and seal the selected return unit at the return manifold.
- 2 Install and seal the selected return unit at the separator. Installing the primary pump (if present).
- 3 Install and seal the selected INAIL section at the delivery manifold.
- 4 Install and seal the selected INAIL section at the separator.

Proceed to install the safety elements contained in the specific kit.

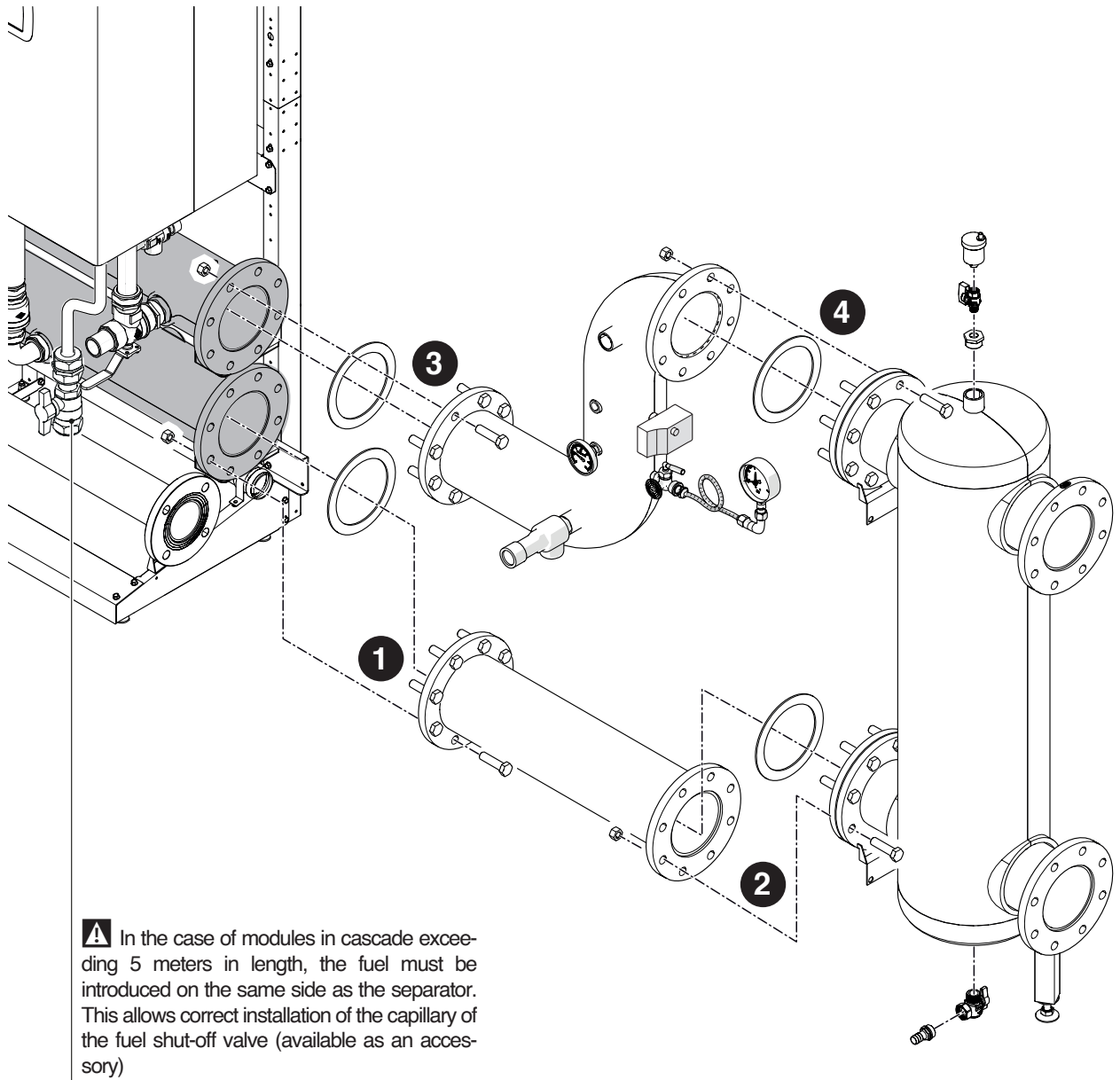

Once all the hydraulic connections have been made, the tightness test of the system can be carried out and the insulation parts can be fitted to complete the system.

- ⚠** Follow the safety and system filling procedures as indicated in the user manual of the individual appliances **POWER MAX**.

CASCADE CONFIGURATION IN-LINE

Assembly of the FLUE SYSTEM DN 160 - DN 200 - DN 250. Components included in code 20131266 - cod. 20132381 - cod. 20131218

- Carefully cut the bends following the measurements indicated. This allows the flue gas outlet duct to slope by at least 3°

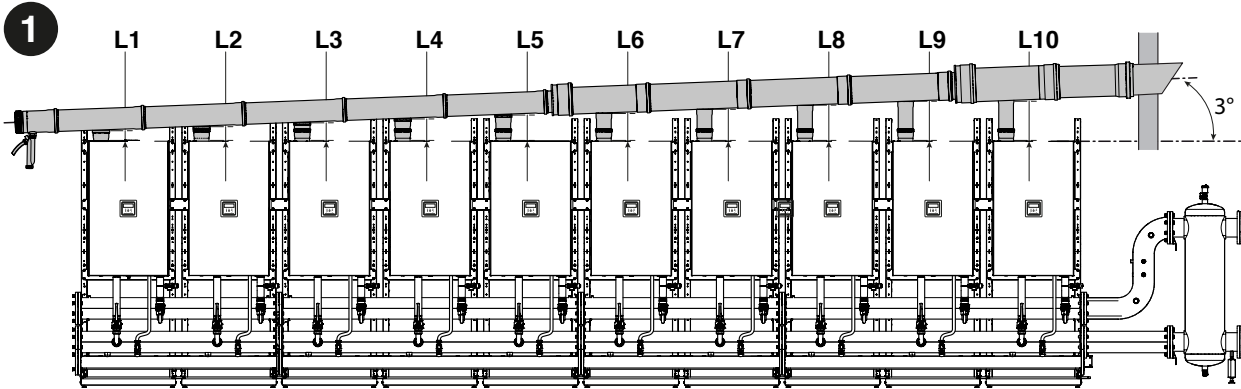

L1	L2	L3	L4	L5	
142	172	202	232	262	mm

L6	L7	L8	L9	L10	
292	322	352	382	412	mm

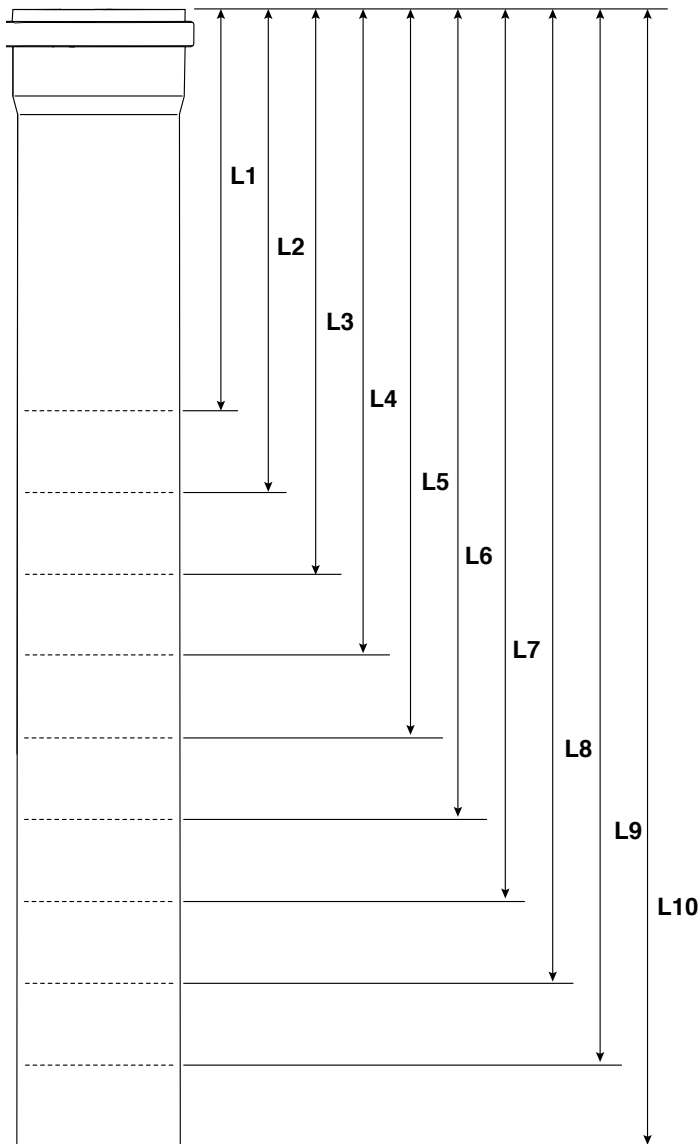

- ⚠** A DN80/DN110 adapter is required **ONLY FOR POWER MAX 65 P MODELS** with flue gas outlet DN80. This adapter is to be installed on the flue outlet and subsequently the cutting lengths must be reduced by 60mm.
- ⚠** **ONLY FOR POWER MAX 150 MODELS**, no more than 8 modules.

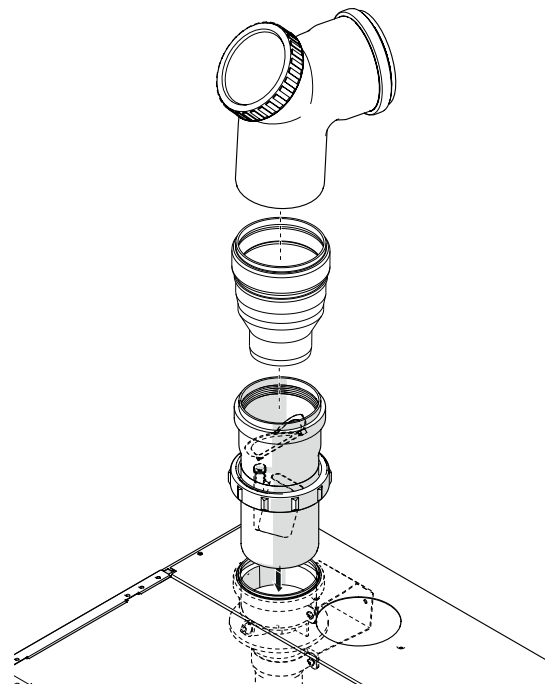

- 2 Pre-assemble the flue gas outlet duct on the ground. Moisten the seals with non-corrosive lubricant (water-based additive with polymers and silicone oil) and make sure that they can be adjusted during the final positioning operations.

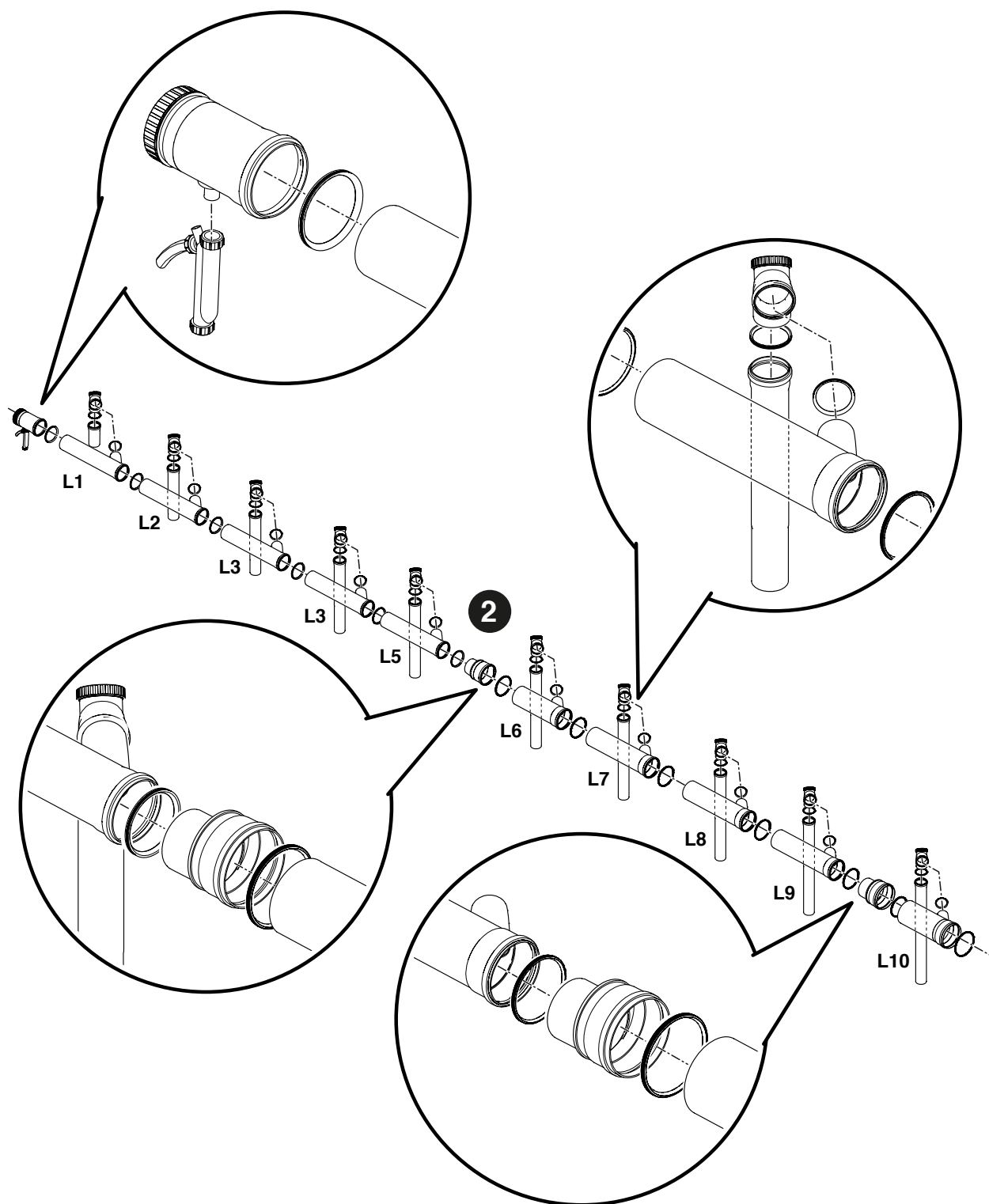

3 Position the flue gas outlet manifold above the modules. Check that a slope of at least 3° towards the condensate outlet siphon is guaranteed.

4 Connect the siphon outlet to the condensate drainage system.

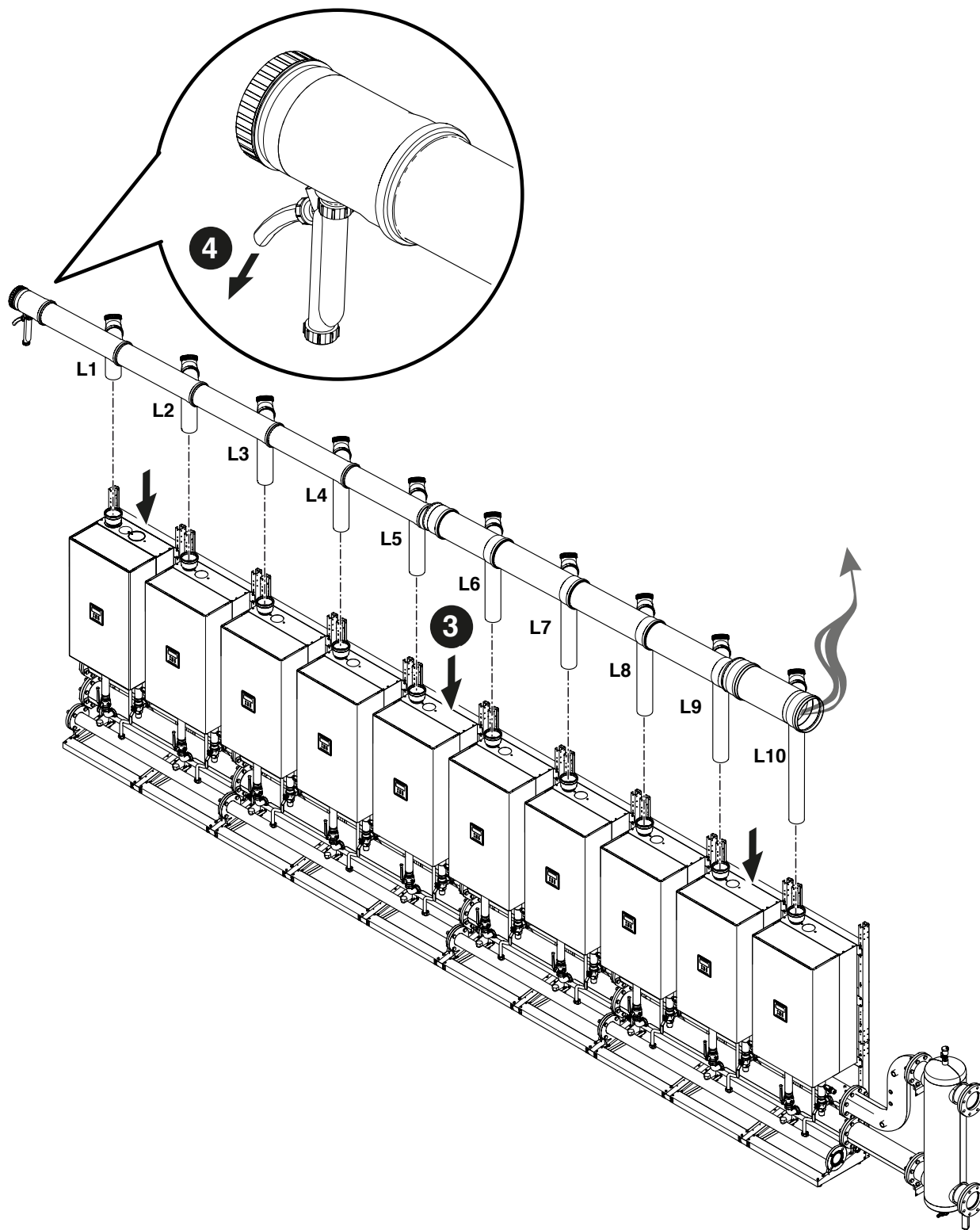

CASCADE CONFIGURATION B2B (BACK TO BACK)

Assembly of the FLUE SYSTEM DN 160 - DN 200 - DN 250. Components included in code 20131266 - cod. 20132381 - cod. 20131218

- Carefully cut the bends following the measurements indicated. This allows the flue gas outlet duct to slope by at least 3°

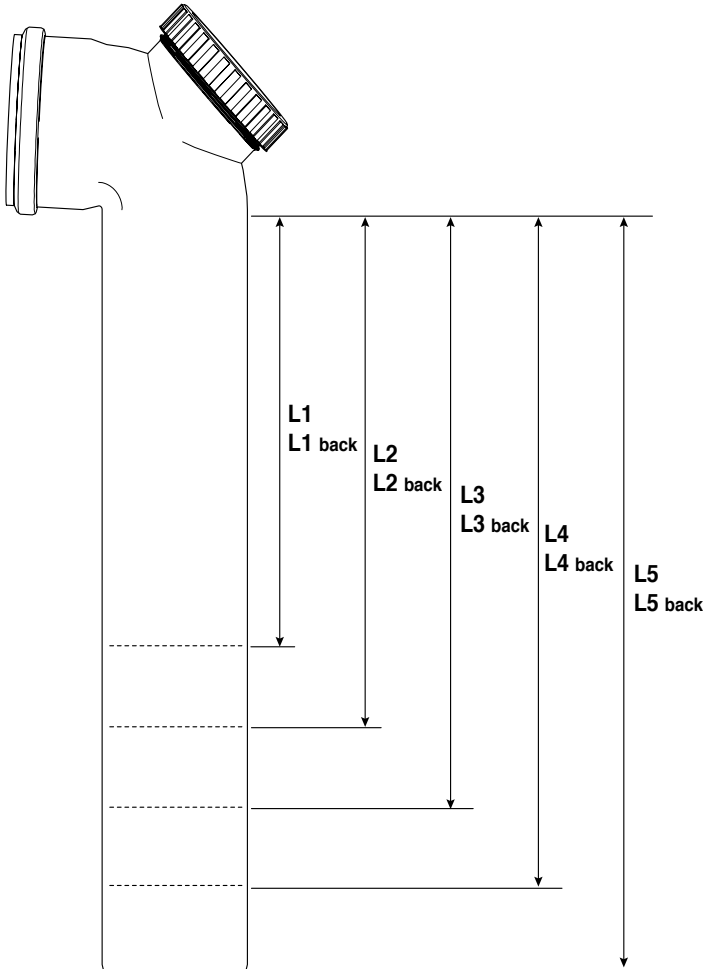
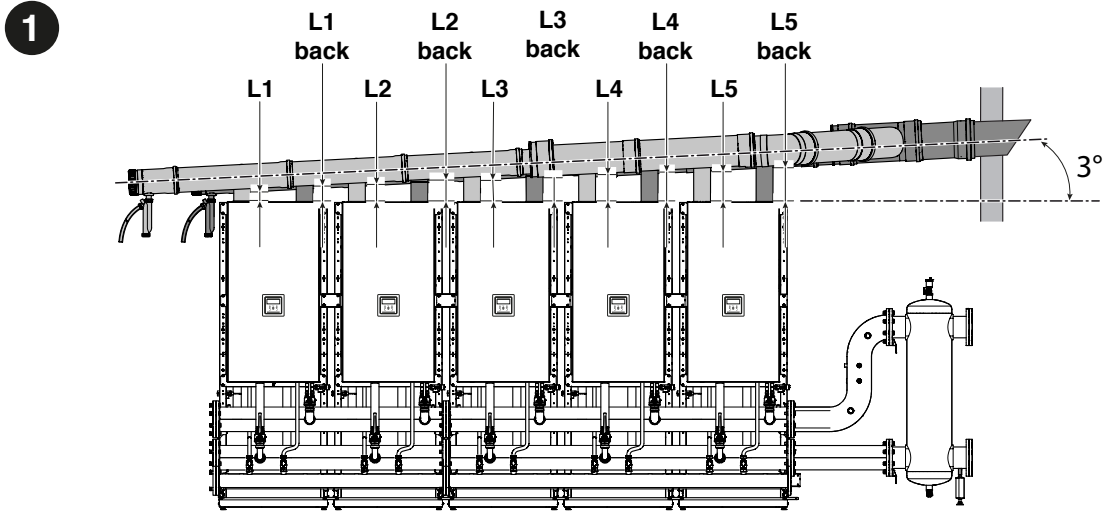

! A DN80/DN110 adapter is required ONLY FOR POWER MAX 65 P MODELS with flue gas outlet DN80. This adapter is to be installed on the flue outlet and subsequently the cutting lengths must be reduced by 60mm.

! ONLY FOR POWER MAX 150 MODELS, no more than 8 modules.

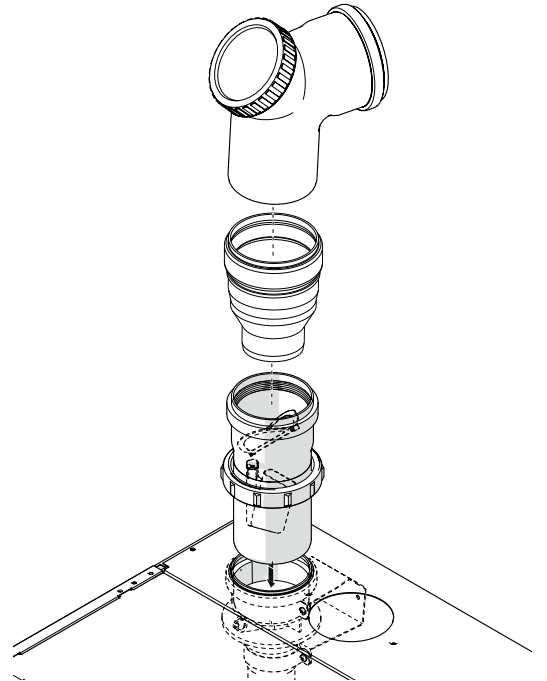

L1 L1 back	L2 L2 back	L3 L3 back	L4 L4 back	L5 L5 back	
172	197	236	275	315	mm

- 2 Pre-assemble the flue gas outlet duct on the ground. Moisten the seals with non-corrosive lubricant (water-based additive with polymers and silicone oil) and make sure that they can be adjusted during the final positioning operations.

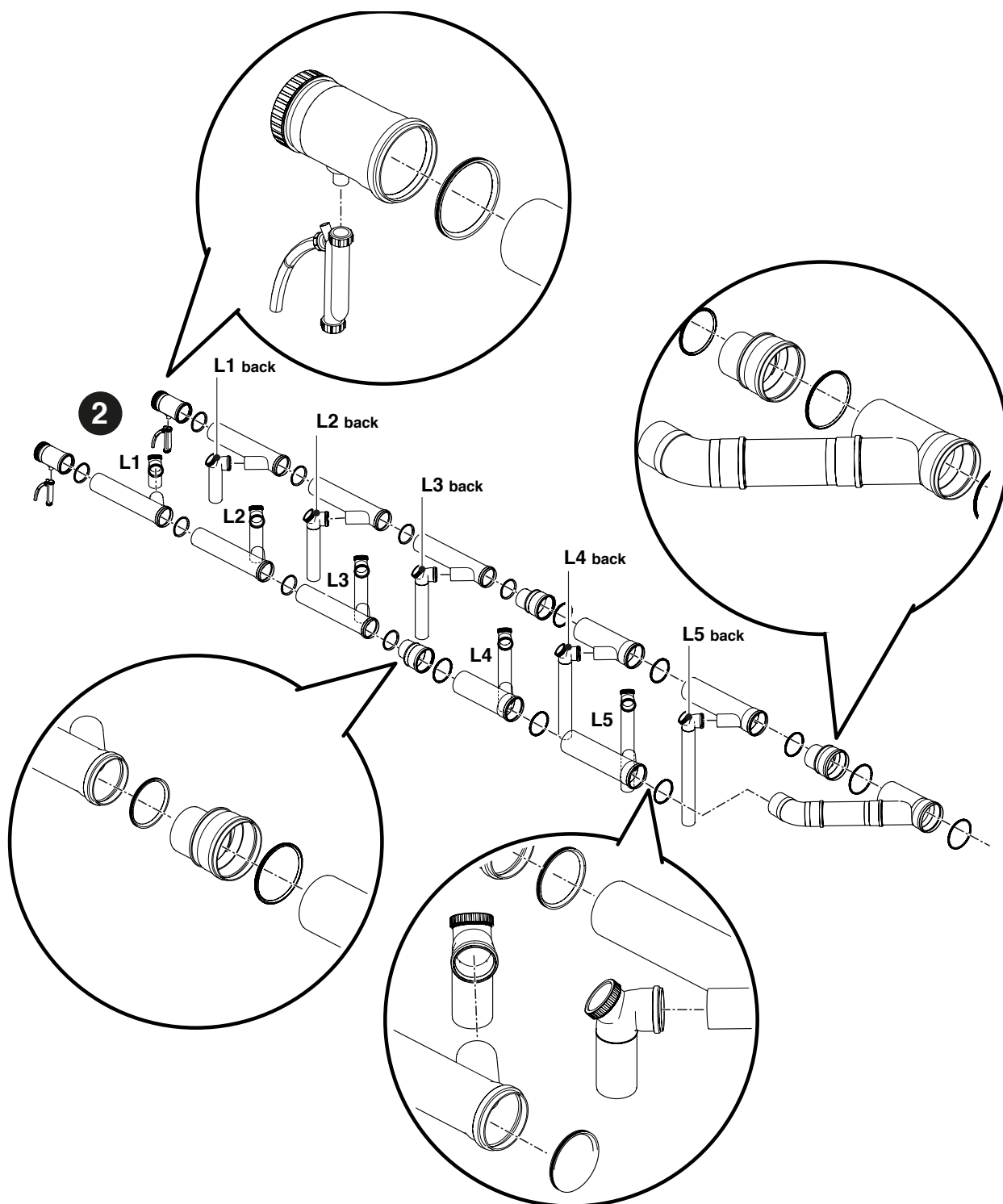

- 3 Position the flue gas outlet manifold above the modules. Check that a slope of at least 3° towards the condensate outlet siphon is guaranteed.
- 4 Connect the siphon outlet to the condensate drainage system.

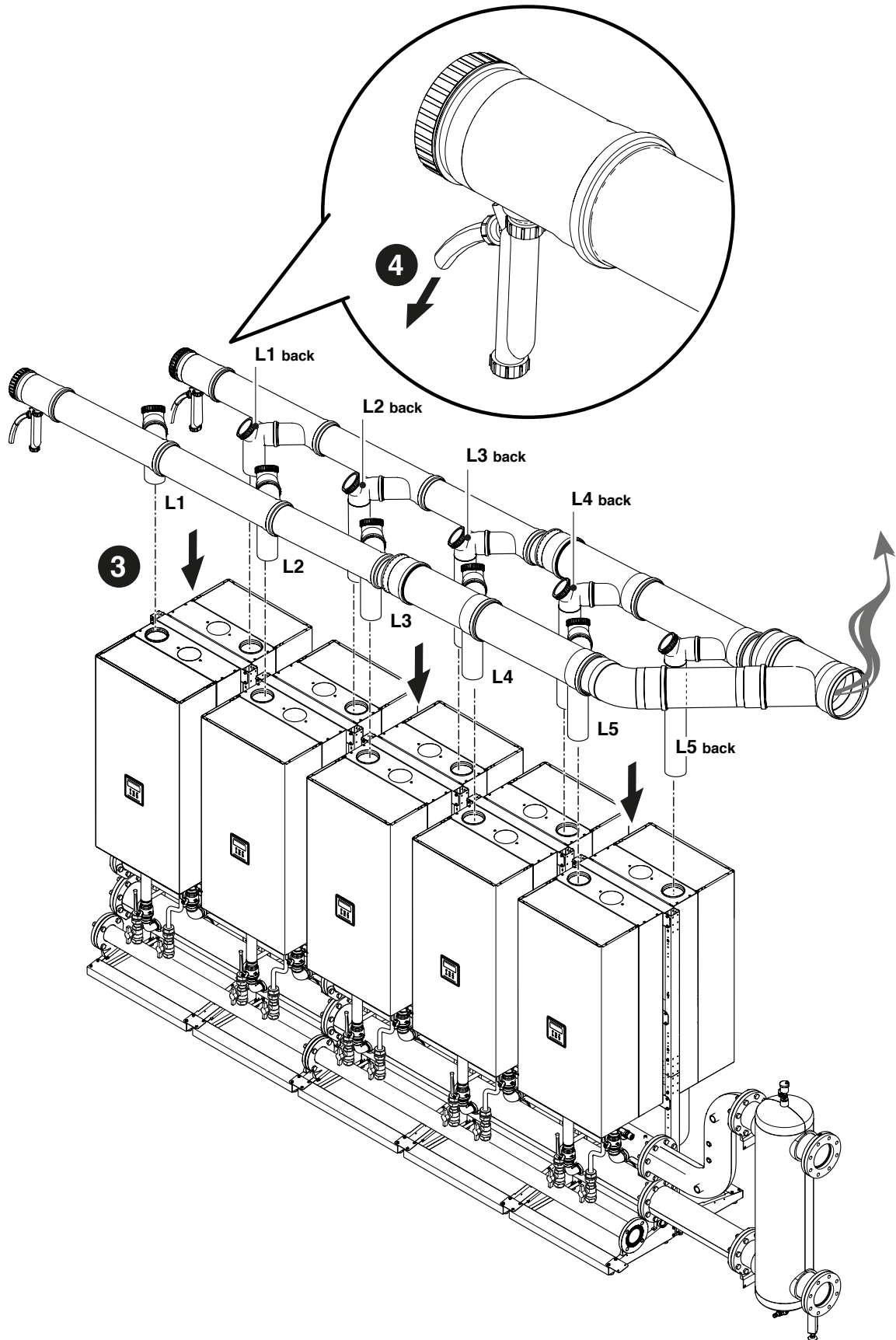

- 5 Complete the flue gas outlet pipe sizing it appropriately and taking into consideration the data in the table indicated below.

	Number of modules	DN flue gas manifold	Maximum length expressed in meters
POWER MAX 65 P	2	160	30
	3	160	30
	4	160	30
	5	160	30
	6	160	30
	7	200	30
	8	200	30
	10	200	30
POWER MAX 80 P	2	160	30
	3	160	30
	4	160	30
	5	160	30
	6	160	30
	7	200	30
	8	200	30
	10	200	30
POWER MAX 110	2	160	30
	3	160	30
	4	160	30
	5	200	30
	6	200	30
	7	200	30
	8	250	30
	10	250	30
POWER MAX 130	2	160	30
	3	160	30
	4	160	30
	5	200	30
	6	200	30
	7	250	30
	8	250	30
	10	250	30
POWER MAX 150	2	160	30
	3	160	30
	4	200	30
	5	200	30
	6	250	30
	7	250	30
	8	250	30

2.10 Neutralization of the condensate

To correctly eliminate the combustion condensate, check if the condensate needs to be neutralized using a designated accessory.

- For systems with a nominal heat input greater than 200 kW, the condensate always needs to be neutralized
- For systems with a nominal heat input greater than 57 kW but less than 200 kW, the selection and evaluation criteria is provided in the figure below

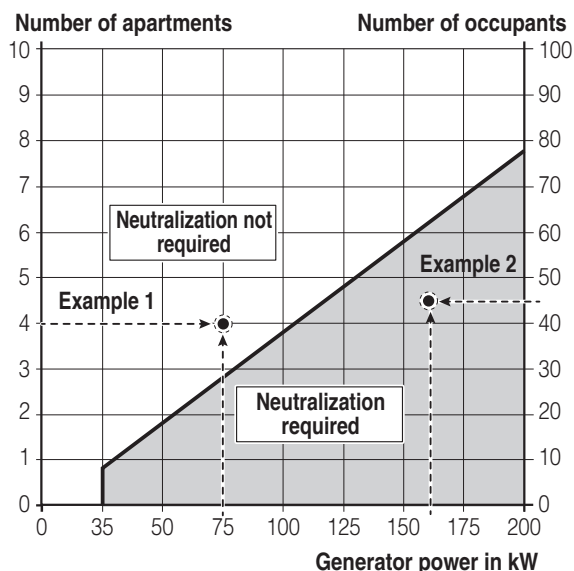

Example 1

For a residential building with 4 apartments, a 75 kW condensing boiler needs to be installed. The 4 apartments / 75 kW intersection point is within the range "neutralization not required", therefore the condensate does not need to be neutralized.

Example 2

For an office block with 45 users, a 160 kW condensing boiler needs to be installed. The 45 users / 160 kW intersection point is within the range "neutralization required", therefore the condensate needs to be neutralized.

In the case of residential applications, reference must be made to the number of apartments served by the system, while in the case of non-residential applications, reference must be made to the number of users.

In the case of mixed applications, the number of apartments must be converted into equivalent users, or conversely, according to the alignment of the two vertical axes, therefore refer only to one axis (for example, 2 apartments equate to 20 users).





The condensate drainage system must be sized and installed to ensure correct elimination of the effluents produced by the appliance and/or by the evacuation system of the combustion products in any and all operating conditions.

3 CONFIGURATION OF THE MAIN BLOCK DIAGRAMS

 The DHW and heating circuits must be completed with expansion vessels of a suitable capacity and correctly sized relief valves. The discharge of the relief valves and the appliances must be connected to an evacuation and collection system (see paragraph Neutralization of the condensate).

 The installer is responsible for selecting and installing the system components and must work in full compliance with correct technical regulations and legislation in force.

 Special supply/refill water must be conditioned using suitable treatment systems.

 For the electrical connections, use H05-VV-F power cables with a minimum cross-section of 1.5 mm², complete with terminal ferrules. For the low voltage connections, use H05-VV-F power cables with a minimum cross-section of between 0.5 and 1 mm², complete with terminal ferrules.

 For the connection of the devices connected to the jig (pumps, circulators and diverting / mixing valves) use interposed relays unless the maximum absorption of all components connected to the board (including the module circulator) is less than or equal to 1.5 A. Relays sizing lays on the installer depending on the type of connected device.

 Never operate the module and the pumps without water.

3.1 Configuration of the primary system

The basic cascade configuration consists of at least two modules. One is assigned "Managing" role and the others are assigned the "Dependent" role.

The cascade of modules can be seen as the primary system of a generation system. This configuration could be ideal for replacing one or more larger generators in an existing system if system reliability and efficiency is to be increased.

In order for cascade operation to be possible, the "Managing" module must be connected to the primary sensor (SS) at least, available as an accessory.

The primary sensor is required in order to manage the cascade setpoint and is essential for managing the modules as a single generator.

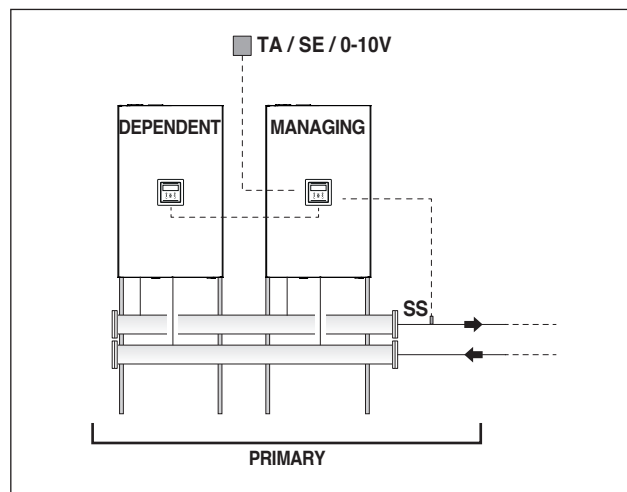

Operation of the primary system can be:

- Mode 0 - With fixed setpoint.
This configuration requires the connection of an ambient thermostat or heat request contact (TA).
- Mode 1 - In climatic mode with variable setpoint based on the outdoor temperature.
This configuration requires the connection of an ambient thermostat or heat request contact (TA) and an external sensor (SE), available as an accessory.
- Mode 2 - In climatic mode with intensity controlled by the ambient thermostat/heat request signal and variable setpoint based on the outdoor temperature.
This configuration requires the connection of an ambient thermostat or heat request contact (TA) and an external sensor (SE), available as an accessory.
- Mode 3 - With fixed setpoint with intensity controlled by the ambient thermostat/heat request signal.
This configuration requires the connection of an ambient thermostat or heat request contact (TA).
- Mode 4 - With delivery setpoint adjustment on the basis of the analogue input 0-10V.
This configuration requires an external device (for example, PLC of the central heating plant) able to generate this signal connected to the analogue input 0-10 V.

The functions described can be set using the parameterization carried out on the "Managing" module. This is described in the manual of the individual modules in the paragraph "Setting the heating system".

The electrical and hydraulic connections of the primary system are to be completed selecting from:

- Use of the module pump (as standard in POWER MAX 65 P - POWER MAX 80 P and available as an accessory for POWER MAX 100 - POWER MAX 150 models).
- Use of the system pump (PS) and two-way valve (V1) for each module (these devices are available as accessories).

3.2 Configuration of the secondary system

Optimal use of the modules in cascade occurs by placing a hydraulic separator (available as an accessory) between the primary system (modules in cascade for thermal generation) and the secondary system (users, such as heat distribution systems, DHW production). This device allows a different flow rate to be compensated between the primary and secondary systems.

For the sake of simplicity, the hydraulic circuits downstream of the separator can be identified as the secondary system. The basic configuration of the secondary system takes place using a system circulator (PI). This circulator, connected to the modules in cascade, allows the transfer of the heat energy to a user circuit to be controlled, for example, a direct zone for high temperature heating of a room.

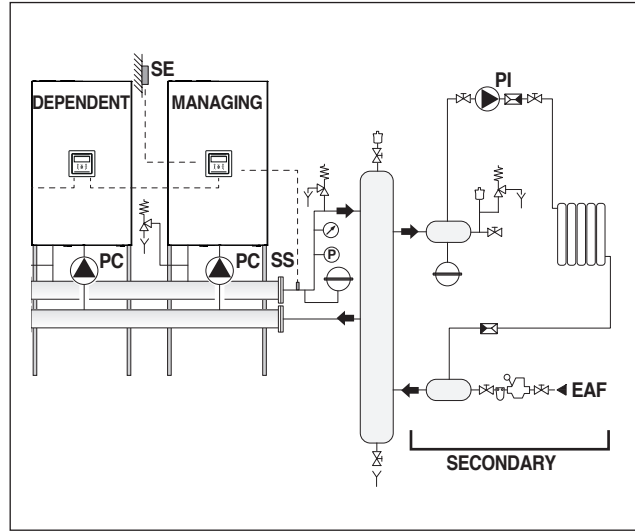
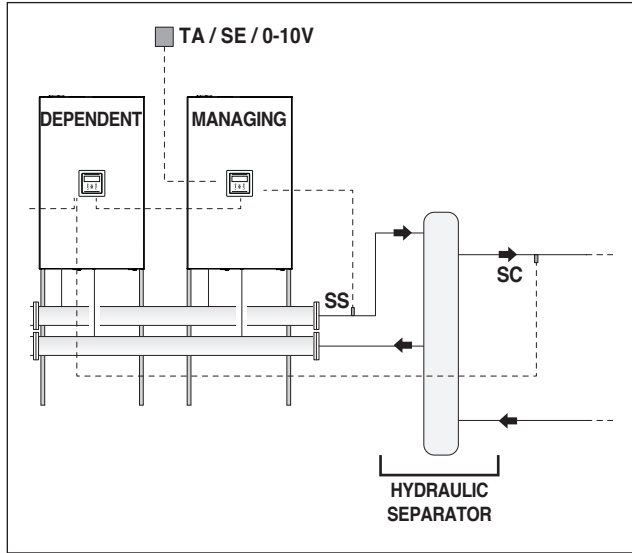

The secondary system can be configured using the following accessories:

- Secondary sensor (SC) or cascade
 This is required in order to manage the setpoint, and therefore the required temperature, downstream of the hydraulic separator.
 The secondary sensor is connected to the controller of the first "Dependent" module.
- Hot water tank sensor (SB)
 This is required in order to manage the production of DHW in combination with a hot water tank circulator (PB).
 The hot water tank sensor is connected to the controller of the "Managing" module.

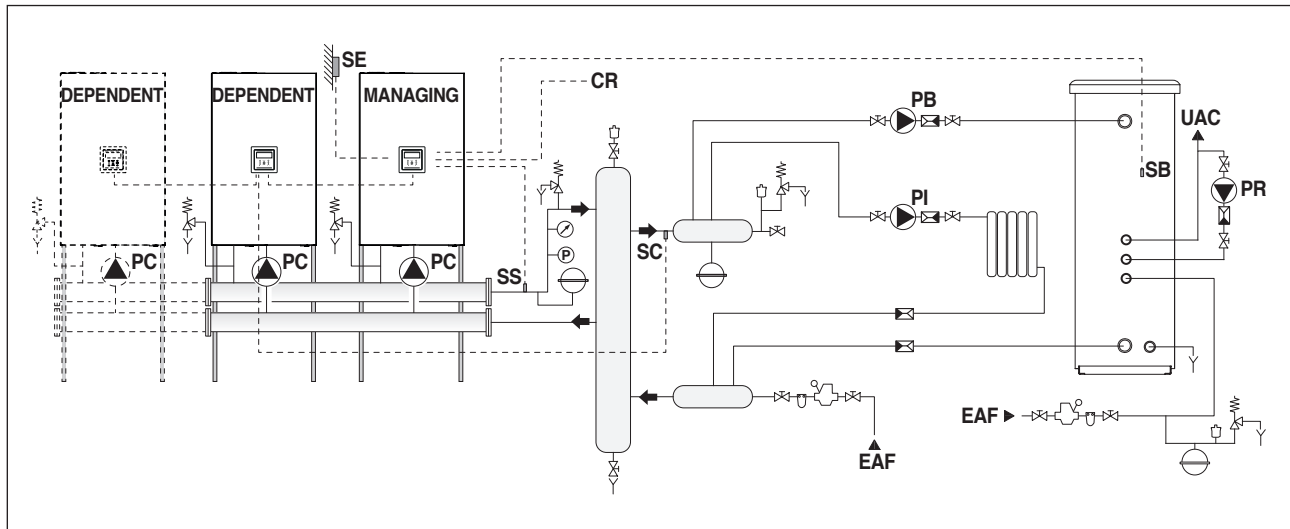

- Zone sensor (S2)

This is required to adjust and control an additional direct zone managed by the "Dependent" module in combination with the zone pump (P2).

The zone sensor is used to adjust and control an additional mixed zone in combination with the zone circulator (P2) and the mixer valve (V2).

The zone sensor (S2), pump (P2) and mixer valve (if present) (V2) must be connected to the "Dependent" module, which communicates via Bus with the "Managing" module.

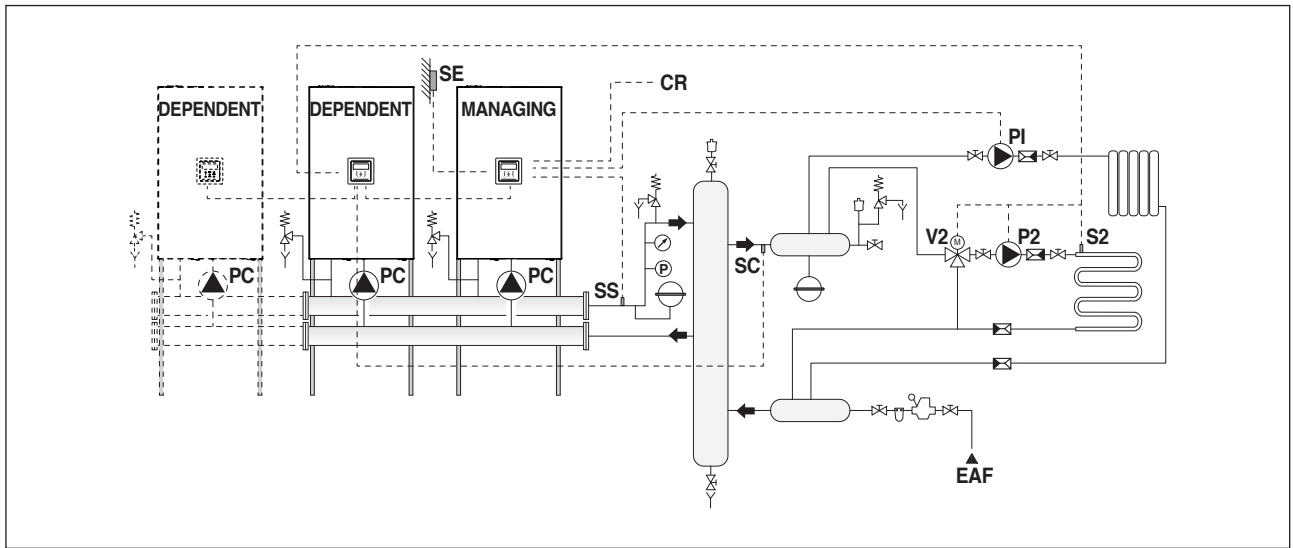

- Zone sensor (S3)

This is required to adjust and control an additional direct zone in combination with an electronic device for zone management (ZM) and the zone circulator (P3).

The zone sensor is used to adjust and control an additional mixed direct zone in combination with an electronic device for zone management (ZM), the zone (P3) circulator and the mixer valve (V3).

The zone sensor (S3), pump (P3) and mixer valve (if present) (V3) must be connected to the electronic device for zone management (ZM), which communicates via Bus with the "Managing" module.

To make the electrical connections, refer to the wiring diagrams of the selected system.

For the Bus connection mode, refer to the section "System management".

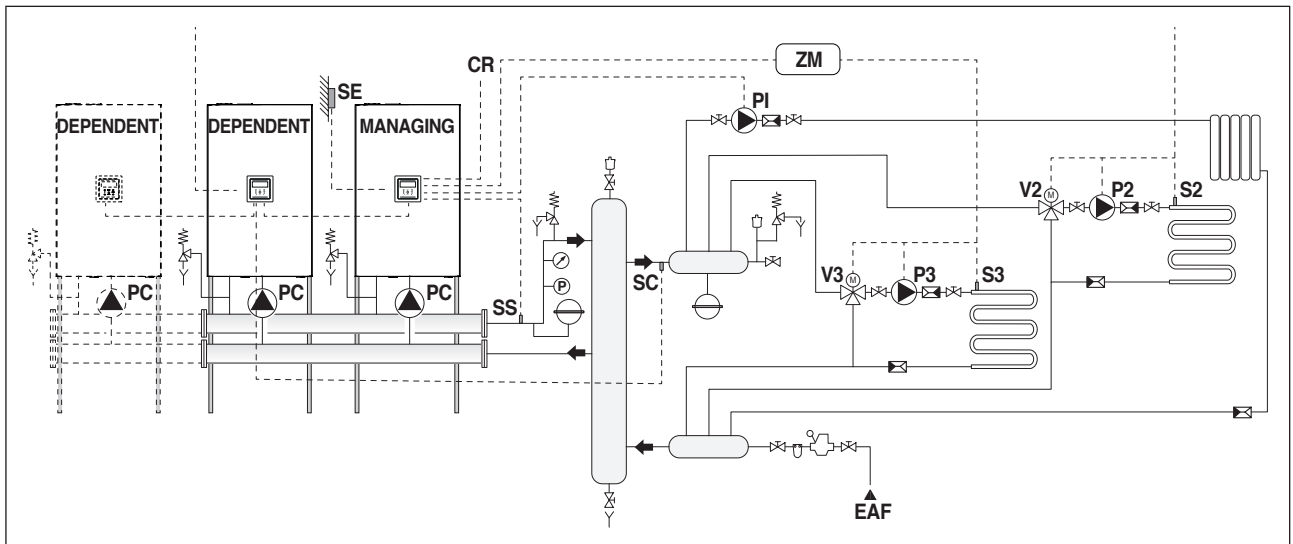

3.3 Block diagram 1: Cascade of modules with primary sensor (SS)

Recommended system diagram for new systems or where the water flow rate in the secondary circuit is equal to that in the primary.

Circuit with modules with their own circulator, connected in cascade.

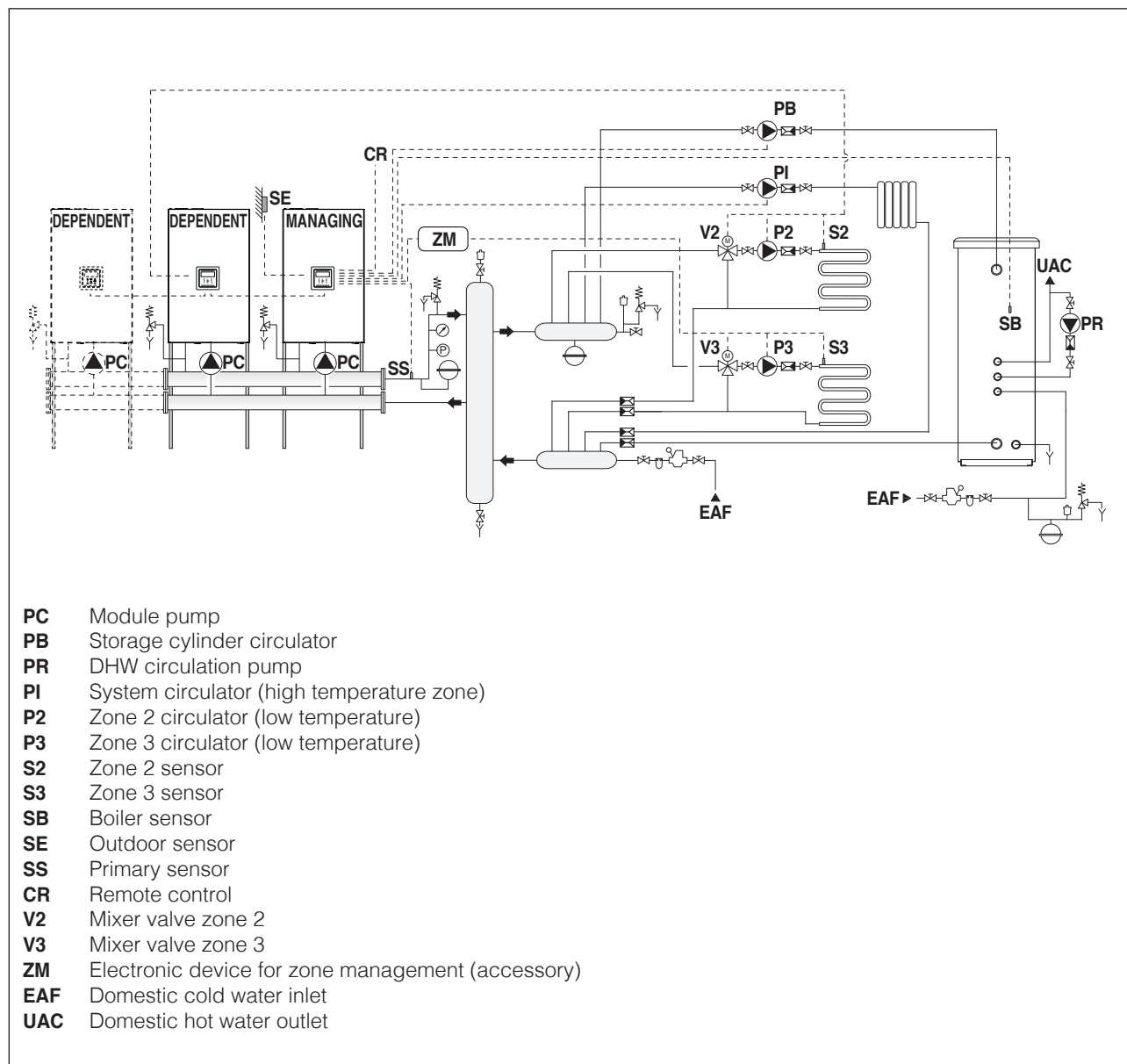

3.3.1 Electrical power connections Block diagram 1

MANAGING CONNECTIONS

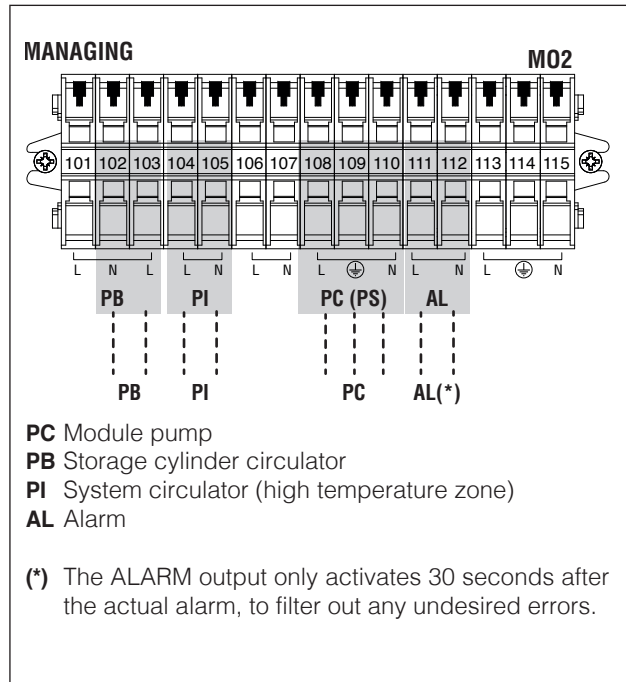

DEPENDENT CONNECTIONS

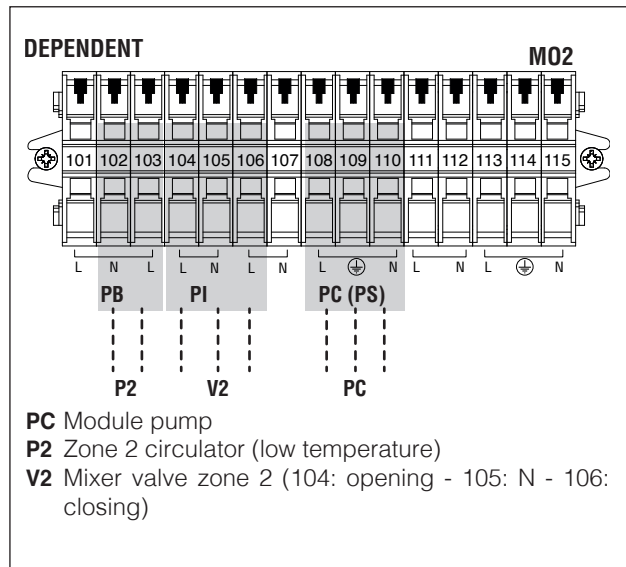

ACCESSORY CONNECTIONS FOR ADDITIONAL ZONE

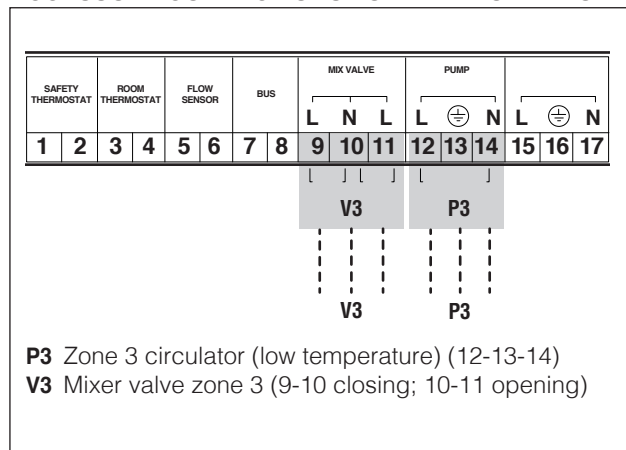

3.3.2 Sensor connections

MANAGING CONNECTIONS

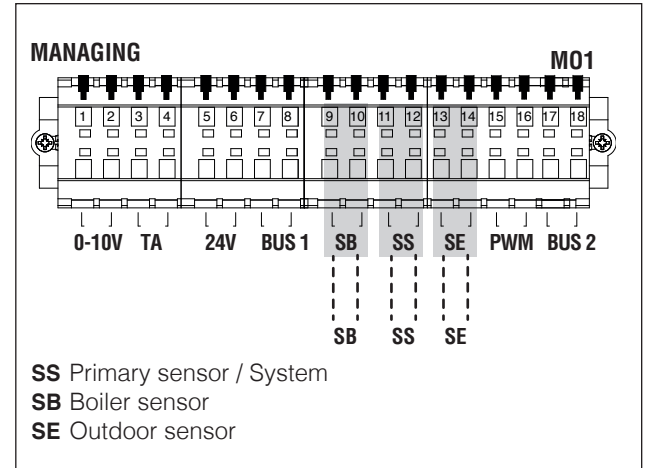

DEPENDENT CONNECTIONS

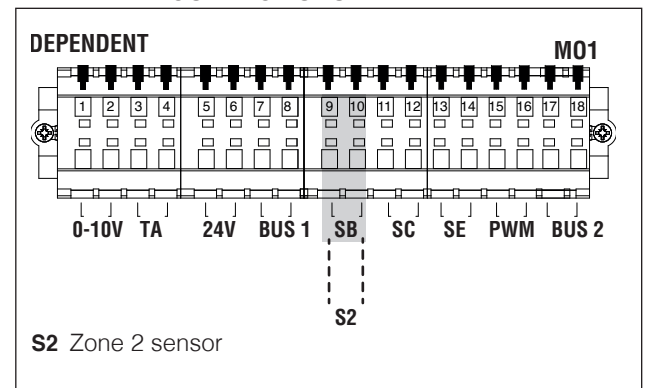

ACCESSORY CONNECTIONS FOR ADDITIONAL ZONE

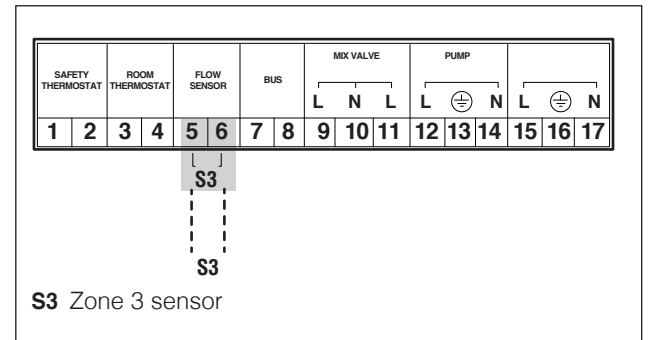

3.3.3 System parameters

Setting switch S1=OFF

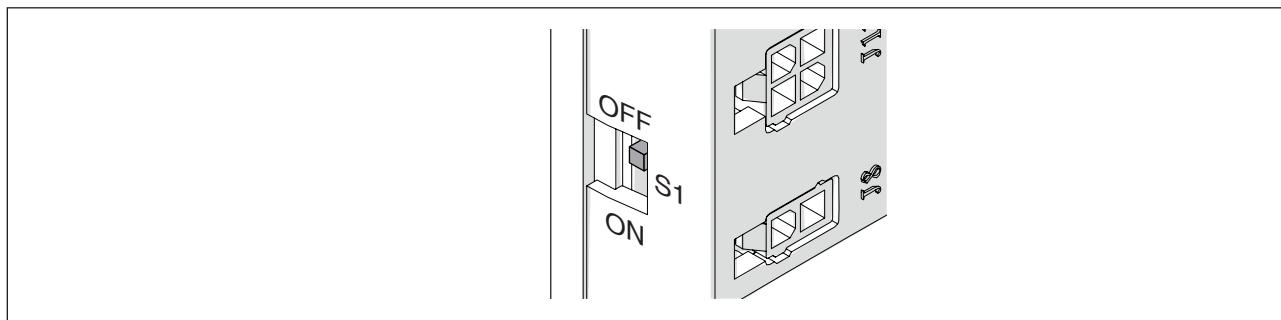

Essential parameters to be configured:

	Description	Default	Managing	Dependent
S1	BUS power supply	Off	(*)	(*)
Dip-switch	Module Address	All 0	1 to ON	2-10 to ON
Par.2189	Module Address	Stand-alone	Managing	Dependent 2-3...16
Par.4147	No. cascade modules	8	TOT number of modules	-
Par.5073	Boiler Address	Stand-alone	Stand-alone	(*)
Par.5167	No. cascade boilers	1	(*)	(*)
Par.2184	No. active DHW units	16	No. modules needed for DHW	(*)

(*) We do not recommend changing the default settings where not stipulated so as not to alter the operation of the appliance.

Specific parameters to be configured:

	Description	Default	Managing	Dependent
Par.4079	Maximum setpoint decrease	2°C	(*)	(*)
Par.4080	Maximum setpoint increase	5°C	(*)	(*)
Par.4081	Waiting time before setpoint modulation	60 min	(*)	(*)
Par.4086	P - Setpoint Modulation	50	(*)	(*)
Par.4087	I - Setpoint Modulation	500	(*)	(*)
Par.2007	Module switch-off hysteresis	5	> 10	> 10

(*) Values recommended for optimum operation.

3.4 Block diagram 2: Cascade of modules with primary sensor (SS) and secondary (SC)

Recommended system diagram for refit systems, when replacing boilers with a high water content or in systems where the water flow rate in the secondary circuit is very different from that in the primary

Circuit with modules with their own pump, connected in cascade. Using the secondary sensor.

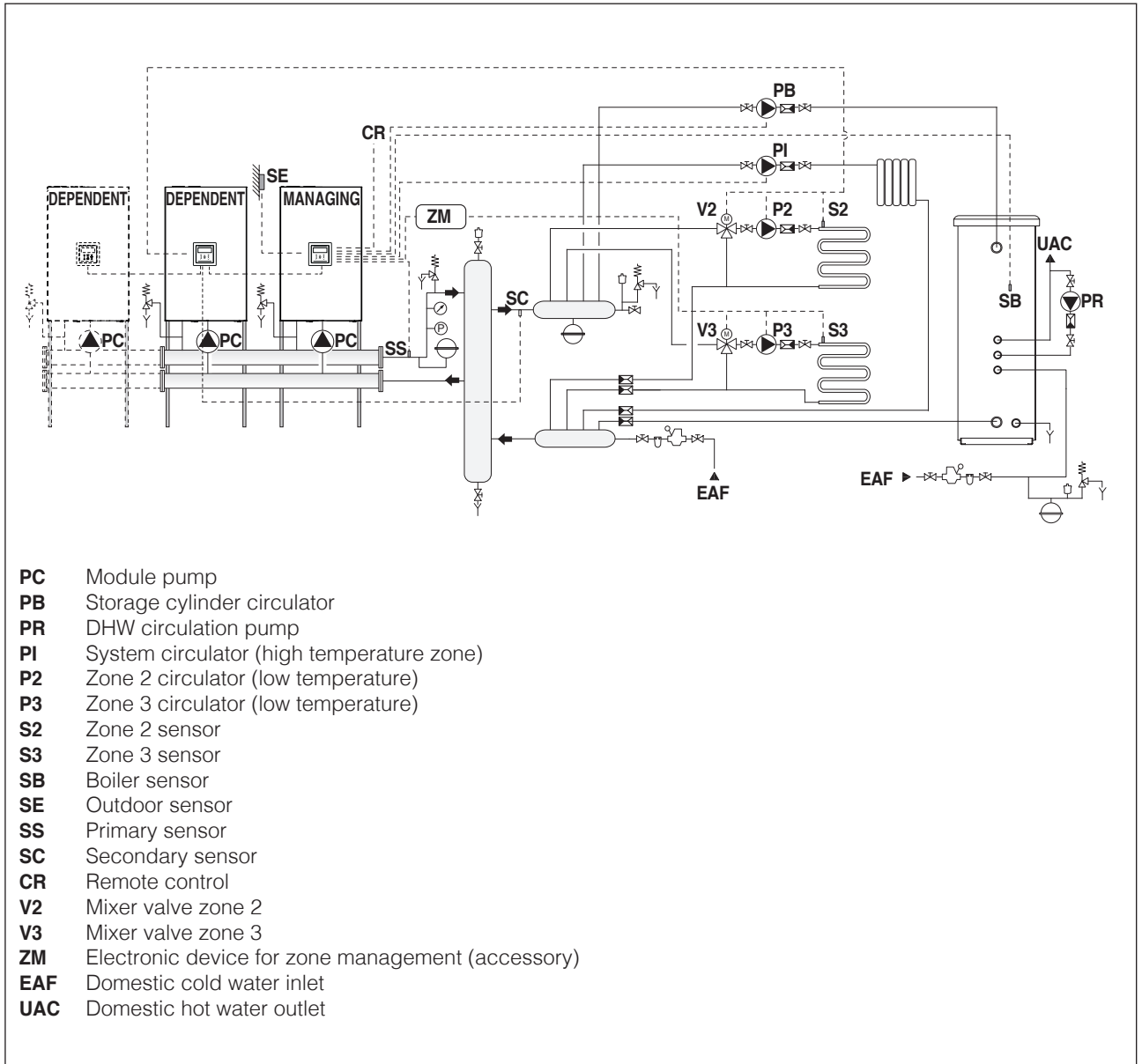

3.4.1 Electrical power connections Block diagram 2

MANAGING CONNECTIONS

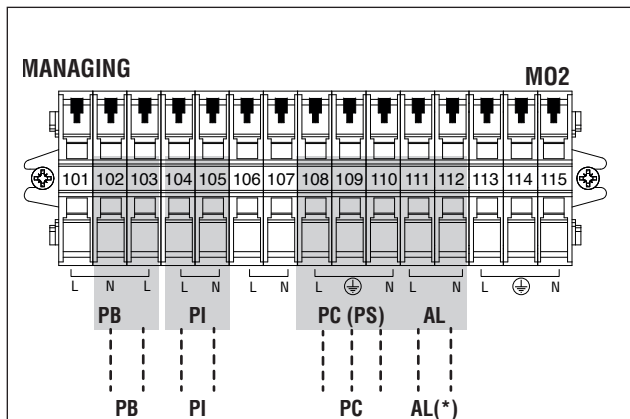

- PC** Module pump
- PB** Storage cylinder circulator
- PI** System circulator (high temperature zone)
- AL** Alarm

(*) The ALARM output only activates 30 seconds after the actual alarm, to filter out any undesired errors.

DEPENDENT CONNECTIONS

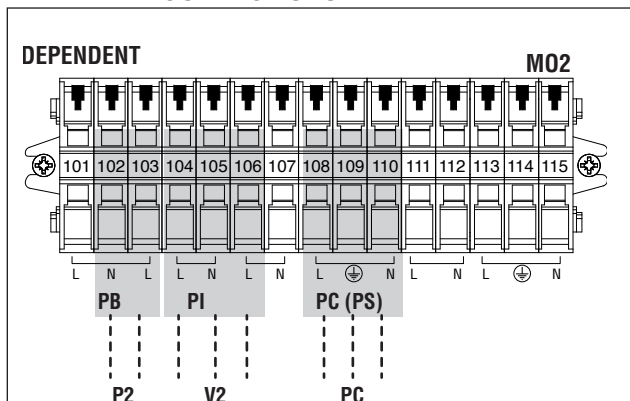

- PC** Module pump
- P2** Zone 2 circulator (low temperature)
- V2** Mixer valve zone 2 (104: opening - 105: N - 106: closing)

ACCESSORY CONNECTIONS FOR ADDITIONAL ZONE

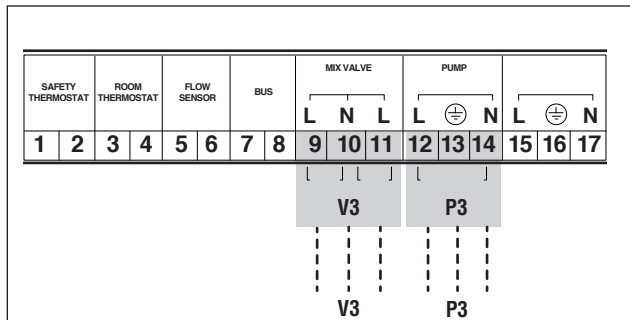

- P3** Zone 3 circulator (low temperature) (12-13-14)
- V3** Mixer valve zone 3 (9-10 closing; 10-11 opening)

3.4.2 Sensor connections Block diagram 2

MANAGING CONNECTIONS

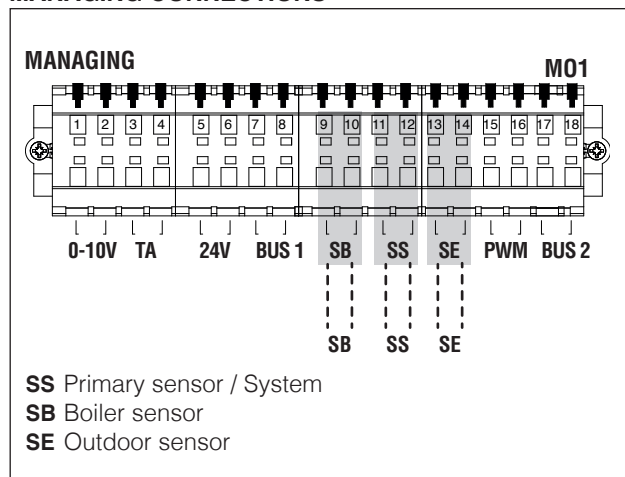

- SS** Primary sensor / System
- SB** Boiler sensor
- SE** Outdoor sensor

DEPENDENT CONNECTIONS

⚠ Connections to be made on the first Dependent module only.

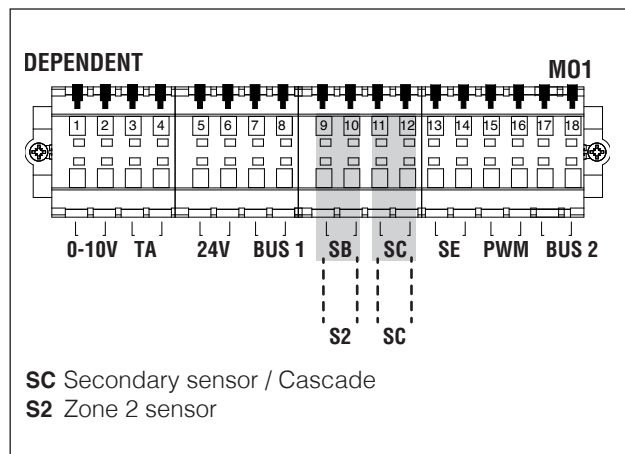

- SC** Secondary sensor / Cascade
- S2** Zone 2 sensor

ACCESSORY CONNECTIONS FOR ADDITIONAL ZONE

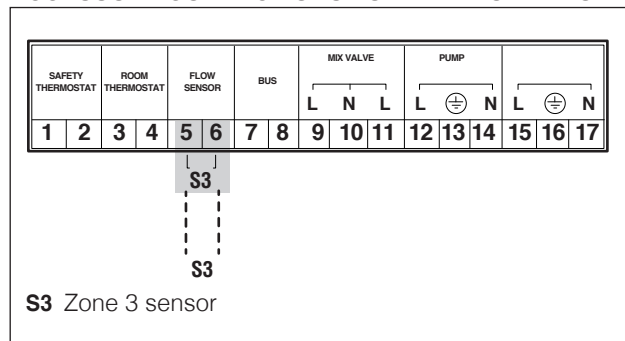

3.4.3 System parameters

Setting switch S1=OFF

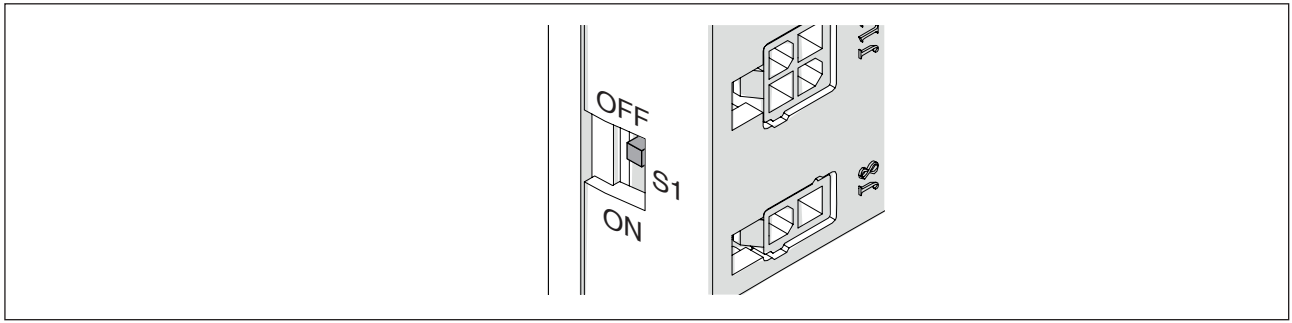

Essential parameters to be configured:

	Description	Default	Managing	Dependent
S1	BUS power supply	Off	(*)	(*)
Dip-switch	Module Address	All 0	1 to ON	2-10 to ON
Par.2189	Module Address	Stand-alone	Managing	Dependent 2-3... 16
Par.4147	No. cascade modules	8	TOT number of modules	(*)
Par.5073	Boiler Address	Stand-alone	Managing	(*)
Par.5167	No. cascade boilers	1	1	(*)
Par.2184	No. active DHW units	16	No. modules needed for DHW	(*)

(*) We do not recommend changing the default settings where not stipulated so as not to alter the operation of the appliance.

Specific parameters to be configured:

	Description	Default	Managing	Dependent
Par.4079	Maximum setpoint decrease	2°C	(*)	(*)
Par.4080	Maximum setpoint increase	5°C	(*)	(*)
Par.4081	Waiting time before setpoint modulation	60 min	(*)	(*)
Par.4086	P - Setpoint Modulation	50	(*)	(*)
Par.4087	I - Setpoint Modulation	500	(*)	(*)
Par.2007	Module switch-off hysteresis	5	> 10	> 10

(*) Values recommended for optimum operation.

3.5 Block diagram 3: Cascade of cascades

If the system is configured with at least two cascades, it is first and foremost necessary to define the Managing cascade in the system: Managing of the Managing

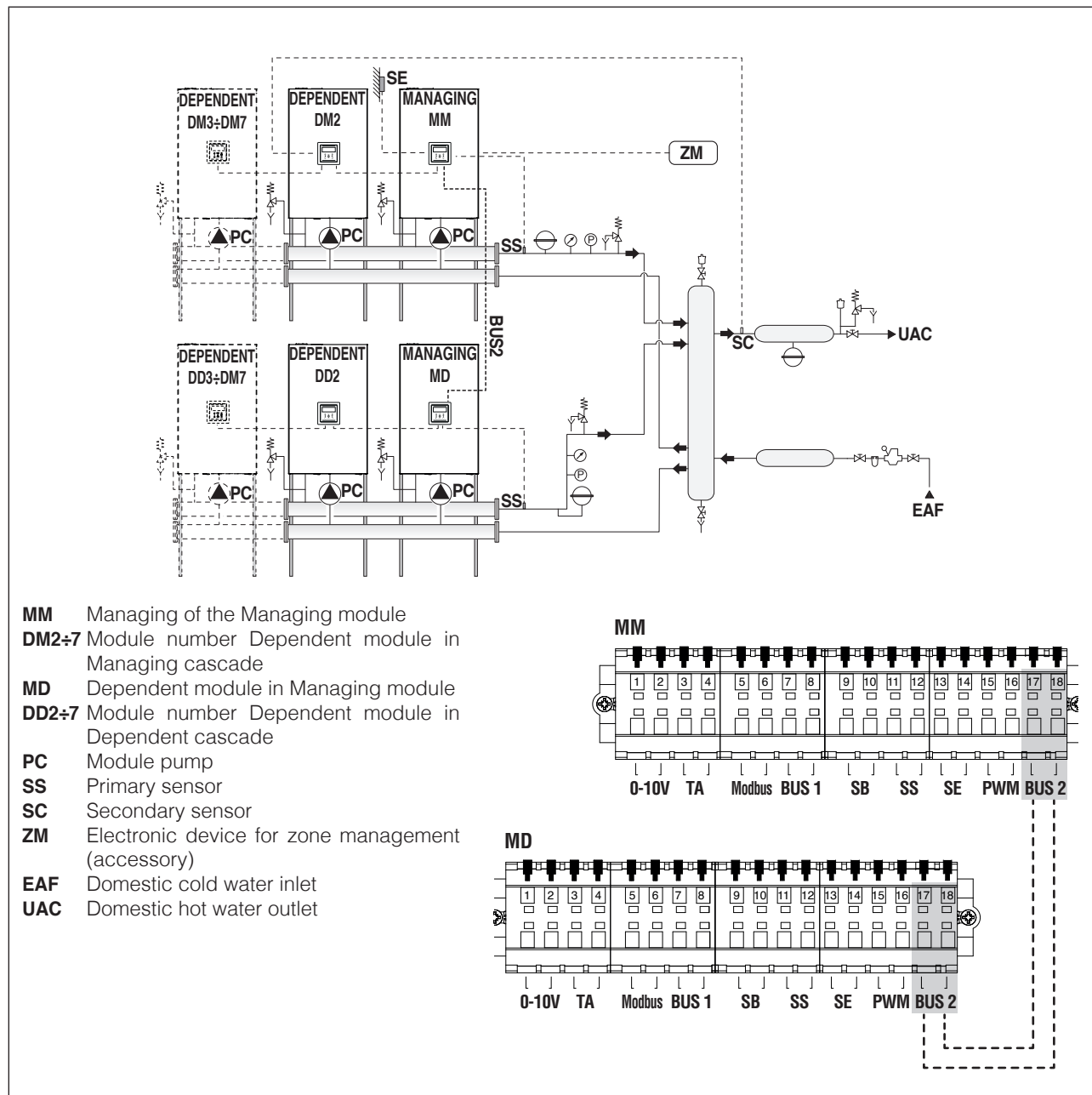

To address the modules and connect the BUS, see Chapter System management.

The modulation of each module depends on the delivery temperature of each unit.

If the SC (secondary) does not reach the setpoint temperature “within a certain time”, the setpoint temperature of the primary is raised.

SS (primary) manages solely the switching on and off of the individual modules.

 In this type of configuration it is NOT possible to manage further External zones and Dependent zones.

3.5.1 Sensor and data bus connections

MANAGING - DEPENDENT CONNECTIONS

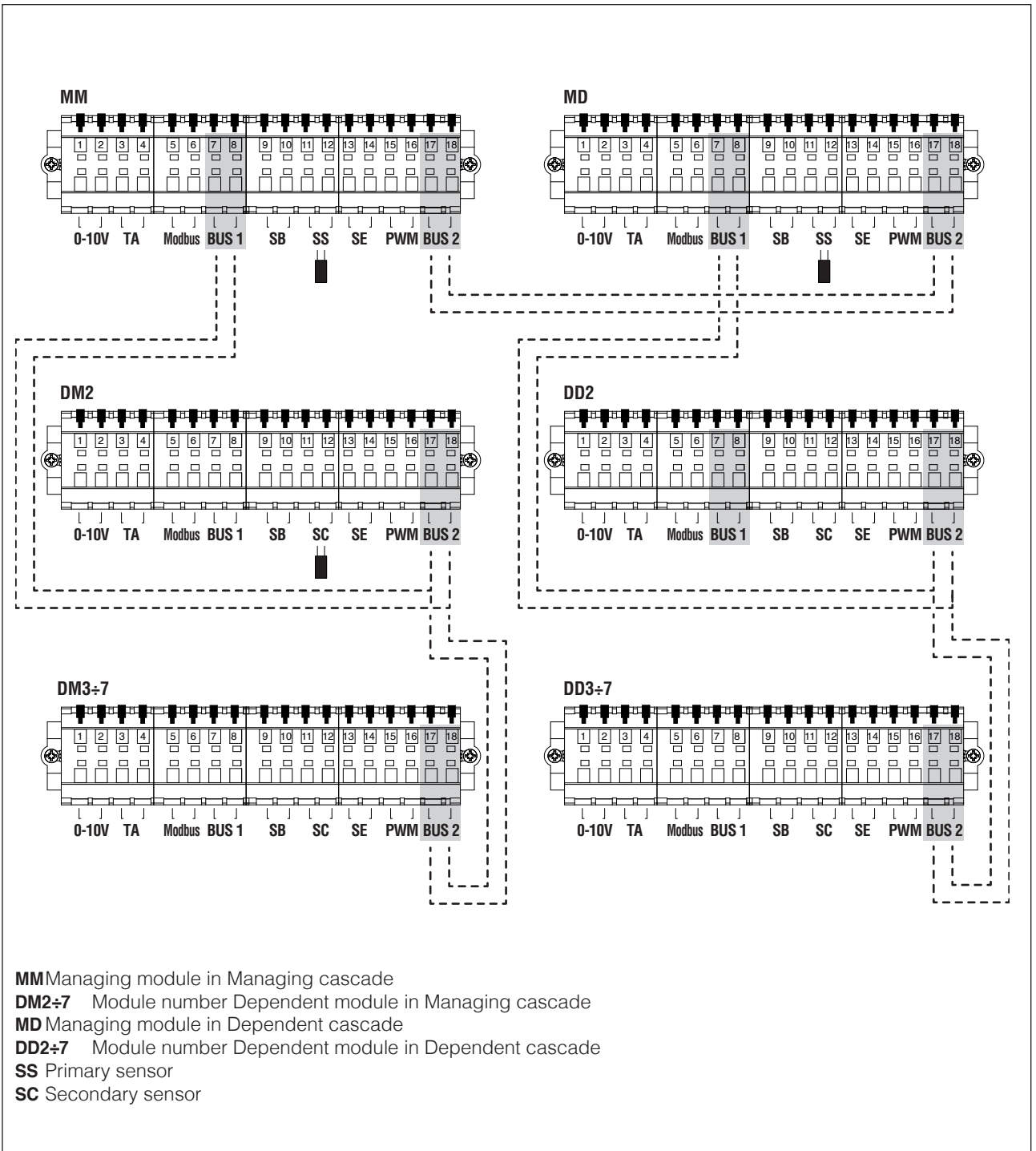

MM Managing module in Managing cascade

DM2÷7 Module number in Managing cascade

MD Managing module in Dependent cascade

DD2÷7 Module number in Dependent cascade

SS Primary sensor

SC Secondary sensor

3.5.2 System parameters

Setting switch S1=OFF

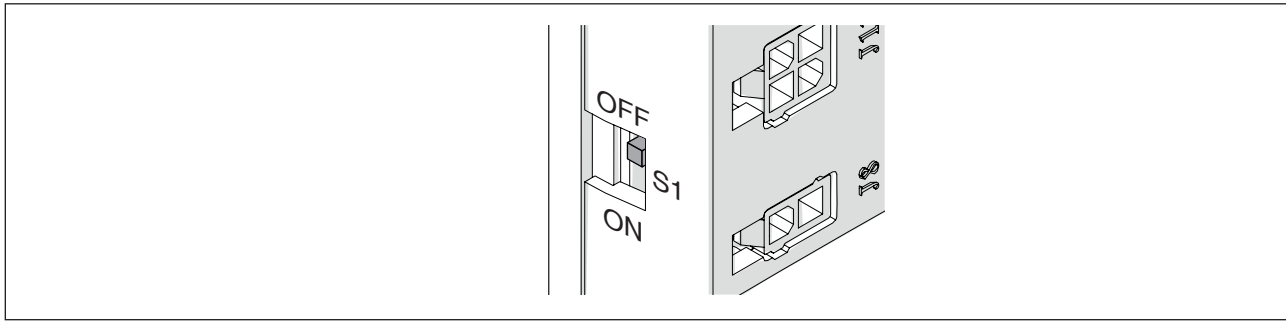

Essential parameters to be configured:

	Description	Default	Managing Cascade		Dependent Cascade	
			Managing	Dependent	Managing	Dependent
S1	BUS power supply	Off	On	Off	Off	Off
Dip-switch	Module Address	All 0	1 to ON	2-8 to ON	1 to ON	2-8 to ON
Par.2189	Module Address	Stand-alone	Managing	Dependent 2-3...16	Managing	Dependent 2-3...16
Par.4147	No. cascade modules	8	TOT number of Managing cascade modules	-	TOT number of Dependent cascade modules	-
Par.5073	Boiler Address	Stand-alone	Managing	-	Dependent	-
Par.5167	No. cascade boilers	1	TOT number of cascades	-	-	-
Par.2184	No. cascades used DHW	16	No. cascades needed for DHW	-	-	-

(*) We do not recommend changing the default settings where not stipulated so as not to alter the operation of the appliance.

65

Specific parameters to be configured on Managing of each cascade (MM - MD):

	Description	Default	Managing (MM)	Dependent (MD)
Par.4079	Maximum setpoint decrease	2 °C	(*)	(*)
Par.4080	Maximum setpoint increase	5 °C	(*)	(*)
Par.4081	Waiting time before setpoint modulation	60 min	(*)	(*)
Par.2007	Module switch-off hysteresis	5 °C	> 10	> 10

(*) Values recommended for optimum operation.

Specific parameters to be configured on Managing in the Managing cascade (MM):

	Description	Default	Managing (MM)
Par.4147	Number of modules in cascade	8	1...10
Par.5156	Delay Per Start Next Blr.	1275	Par.4075 x (No. of modules connected to MM + 1)
Par.5156	Delay Per Stop Next Blr.	1275	Par.4076 x (No. of modules connected to MM + 1)
Par.5156	Next Quick Start Delay	400	Par.4142 x (No. of modules connected to MM + 1)
Par.5156	Next Quick Stop Delay	240	Par.4143 x (No. of modules connected to MM + 1)
Par.5167	Number of boilers connected (cascade of cascades)	1	1...8
Par.5169	Maximum setpoint decrease	2°C	(*)
Par.5170	Maximum setpoint increase	5°C	(*)
Par.5171	Waiting time before setpoint modulation	40 min	(*)

(*) Values recommended for optimum operation.

4 SYSTEM MANAGEMENT

Communication between all the modules installed is a fundamental aspect in a system with multiple modules.

The essential steps for configuration are:

- allow the Managing module to recognise which and how many dependent modules are present in the system. Act on the dip-switch
- connect the modules with a BUS cable to allow communication between the control units.

4.1 Module addressing via dip switches

The dip switches of all the modules in the system must be set, and each must be set with an unequivocal sequence. This way the controller of the Managing module will be able to recognise which modules are present in the system.

To access the dip-switches, open the hatch using a flat-bladed screwdriver.

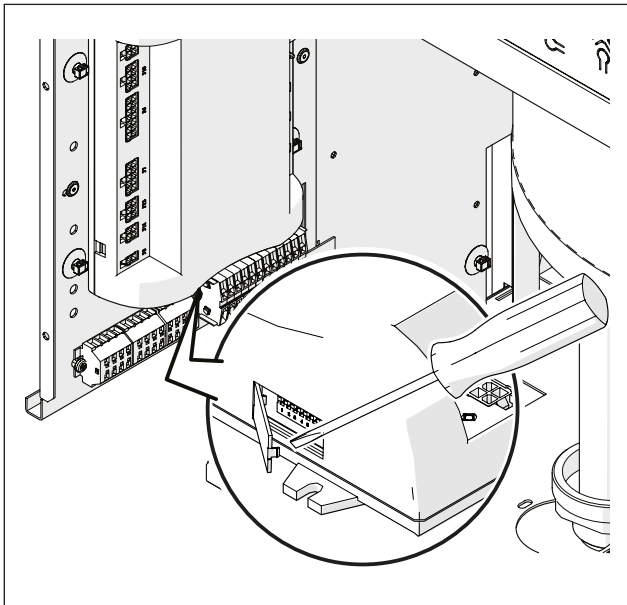

! The setting must be carried out on each module. For configuration of the individual module, refer to the following table.

Key	
	Dip switch ON
	Dip switch OFF
Setting the Dip-switch	Module Configuration
	Stand-alone module (all the dip-switches set to OFF, configuration not used in cascade)
	1st module (Managing)

Setting the Dip-switch	Module Configuration
	2nd module (Dependent)
	3rd module (Dependent)
	4th module (Dependent)
⇩	⇩
	8th module (Dependent)
	9th module (Dependent)
	10th module (Dependent)

! If two modules have the same Dip-switch setting, the Managing module will signal a communication error and the cascade will not work correctly.

! A module will not be considered if it has the setting of all the Dip-switches set to OFF.

4.2 Bus connections

Identify the terminals located below the controller. The bus connections are to be made on the low voltage terminal board (M01).

Module terminal board

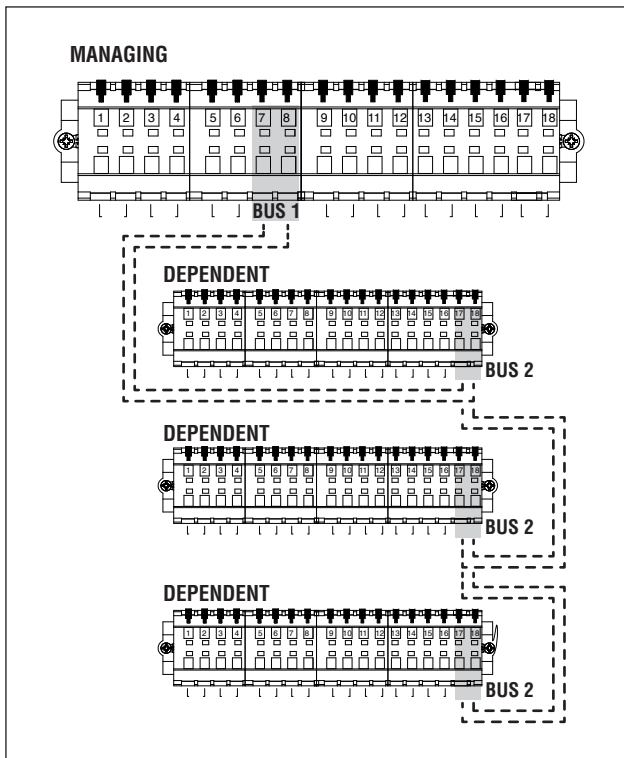
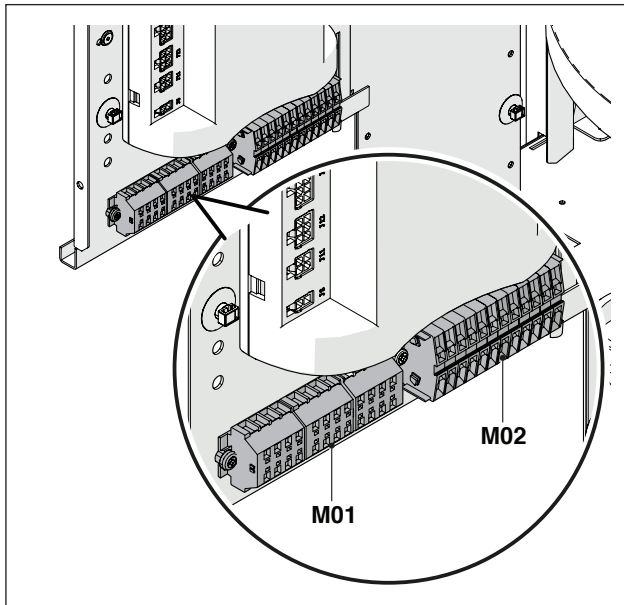

⚠ The bus connection to the dependent modules must be made in parallel without the closing terminal which would cause a short circuit.

4.3 Connection to External Zone controller

⚠ With a Cascade of Cascades it is NOT possible to manage further external zones.

The mixed zone controller connected to the system must be set with a specific number of recognition actions, so that the electronic board of the module recognises which zone is making the heat request.

The number of recognition actions is set with the help of the jumpers to be applied to each pair of pins.

⚠ The setting must be carried out on each board of the additional zone accessory. To assign the required number to the additional zone, refer to the following table, applying the jumpers to the positions illustrated from 1-4.

⚠ If two zones have the same address, one of the two will not be recognised.

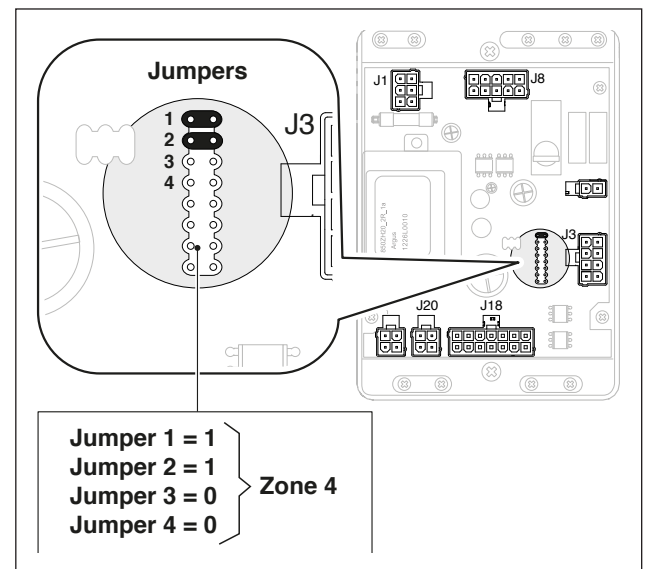

Jumpers				Zone number
4	3	2	1	
0	0	0	0	1
0	0	0	1	2
0	0	1	0	3
0	0	1	1	4
0	1	0	0	5
0	1	0	1	6
0	1	1	0	7
0	1	1	1	8
1	0	0	0	9
1	0	0	1	10
1	0	1	0	11
1	0	1	1	12
1	1	0	0	13
1	1	0	1	14
1	1	1	0	15
1	1	1	1	16

⚠ To configure the parameters, refer to the manual of the kit provided.

4.4 Removing external zone

To remove an External zone, enter the "Information" menu:

- enter "Status zone dep.";
- select the number of the dependent zone;
- The "Detection" field will indicate "NO";
- select "Remove zone" changing to "YES" and confirm.

Now in the "Settings" and "Information" menus the dependent zone will no longer be displayed.

The electronic control of the module will automatically check which zones are connected to the bus.

The menu items of the zone in the electronic control of the module will be available when 1 or more zone management devices are detected.

The electronic control of the module remembers the zone number detected when a device is connected.

The zone number detected is not automatically removed when the corresponding accessory is no longer connected.

The zone number needs to be removed manually.

Removing the zone number

- remove the bus connection of the zone to be deleted;
- access the Settings/Zone Config./Zone;
- select the disconnected zone;
- go to Remove Zone;
- press the ► key to highlight the values, change them to "Yes" with the ▲ / ▼ keys, press the ● key to confirm and remove the zone from the display menus.

Example:

External Zone 3	
Detection	No
Remove Zone	No

External Zone 3	
Detection	No
Remove Zone	Yes

4.5 Configuration of Dependent zones



Configuration not possible with a Cascade of Cascades.

If used on a cascade system, with heating zone control using DEPENDENT module, after carrying out the connections as described in the Cascade Manual, the following modifications need to be made.

On the display of the Dependent module to which the zone is connected:

Par. 9097

- if configured with value = 1 (use with circulator) it must be changed to value = 9
- if configured with value = 2 (use with 2-way valve) it must be changed to value = 8



The 9097=8 configuration CANNOT be applied to models with a boiler circulator installed as standard.

Par. 2205

By default the parameter is disabled. To enable the recognition of the zone the value must be changed from "DIS" to "ENA" and confirmed.

When the modifications are complete the following new functions will be available on the display of the device:

- in the "Information" menu the number of the connected zone appears (zone of the dependent), from where it is possible to display information about it;
- in the "Settings" menu two new lines will be displayed:
 - "Config. Zone Dep."
 - "Clim. Curve Zone Dep."
- The following new row will appear in the "Clock program" menu:
 - "Program CH Zone Dep."

Cascade connection

MANAGING

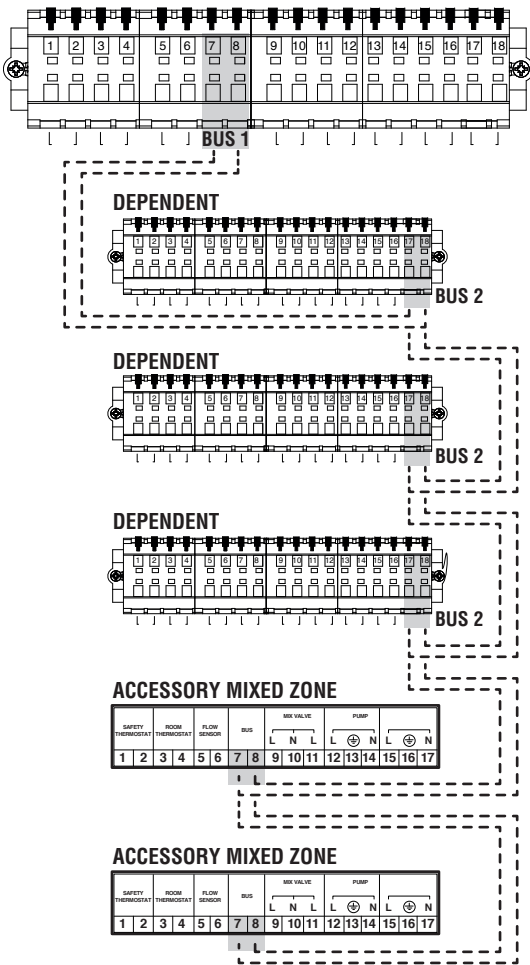

4.5.1 Deleting dependent zone

To remove a Dependent zone operate in the reverse way to its installation:

- enter the parameters menu and select the par. 2205. Change its value from "ENA" to "DIS";
- change the par. 9097. If par. 9097 = 9 change to = 1; if par. 9097 = 8 change to = 2.

5 COMMISSIONING AND MAINTENANCE

5.1 Repositioning the front panels

Before putting the appliance into service, make sure that all the modules have been reassembled with their own front panel:

- 1 Insert the panel into the seats on the points (B).
- 2 Push it forwards until contact is made and then secure using the designated screw (A).

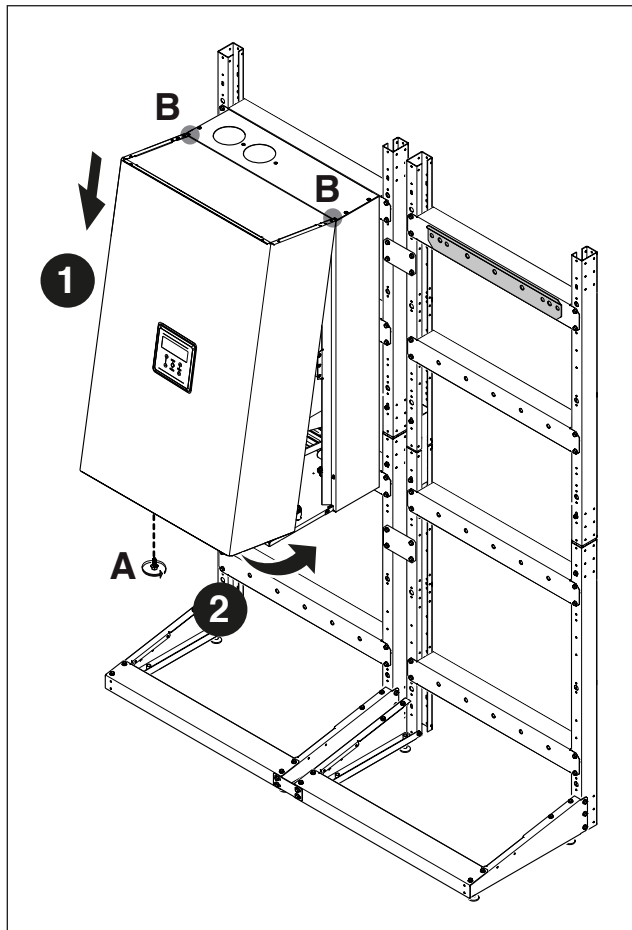

5.2 Putting the system into service

The first time the **POWER MAX** is used, the following checks and operations must be carried out:

- Check that the gas cock and heating water cock are open

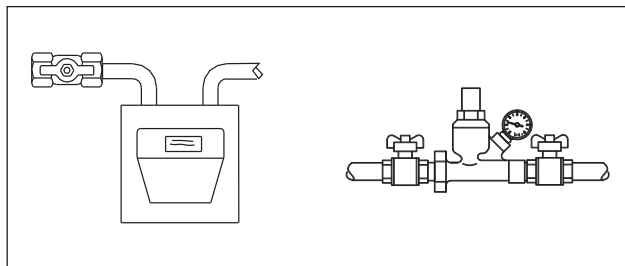

- Check that the pressure of the hydraulic circuit when cold is always greater than 1 bar and less than the maximum limit permitted for the system

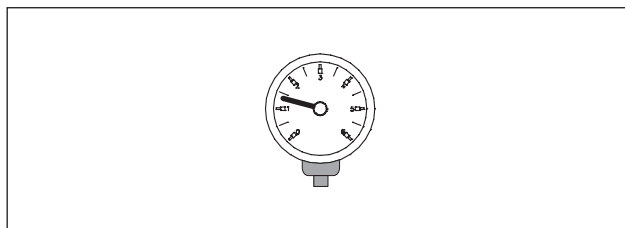

- Set the main switch of the system to ON and the main switch of all the modules to (I), starting with the Managing module.

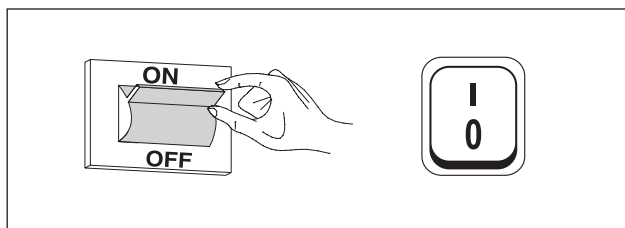

5.3 Electronic control

 For further information on the electronic control, refer to the specific section in the user manual of the individual appliance **POWER MAX**.

5.3.1 USER navigation MENU

At power-on, or when no key is pressed for more than 4 minutes, the display enters the 'basic view' mode and provides general information about the operation of the module.

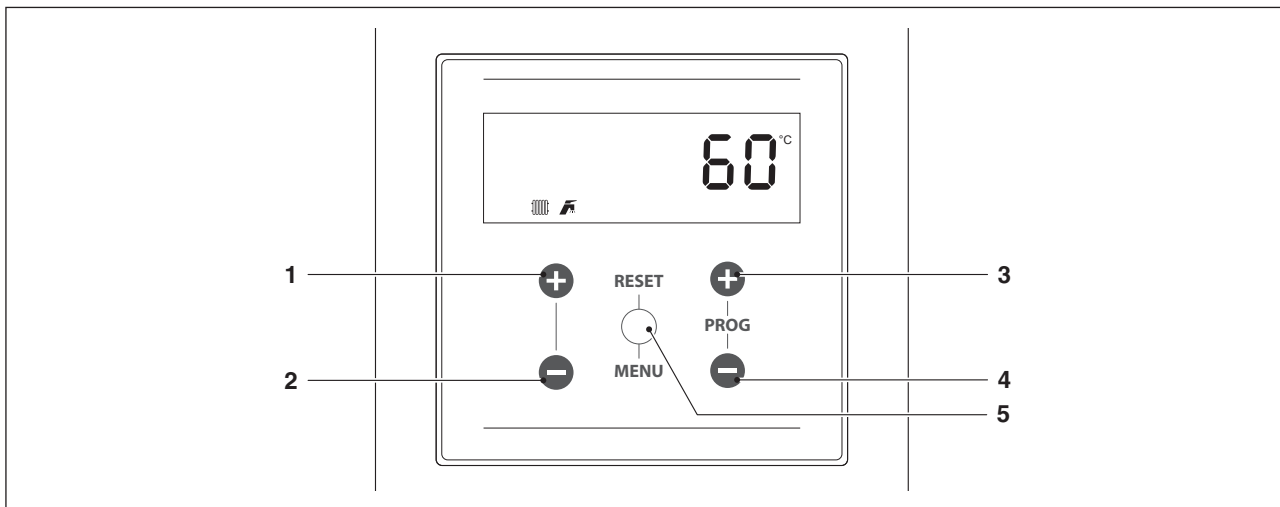

In this mode, keys have the following functions:

Nr.	Button	Function
1	"+"	Raise the heat set point (when available)
2	"-"	Decrease the heat set point (when available)
3	"PROG +"	Raise the DHW set point (when available)
4	"PROG -"	Decrease the DHW set point (when available)
5	"MENU/RESET"	Enters into "MENU" mode If pressed for more than 2 seconds, it resets a non volatile failure

MENU selection

Enters into "MENU" mode when "MENU/RESET" key is pushed. The figures of the small display indicate "0000" which is the first accessible menu.

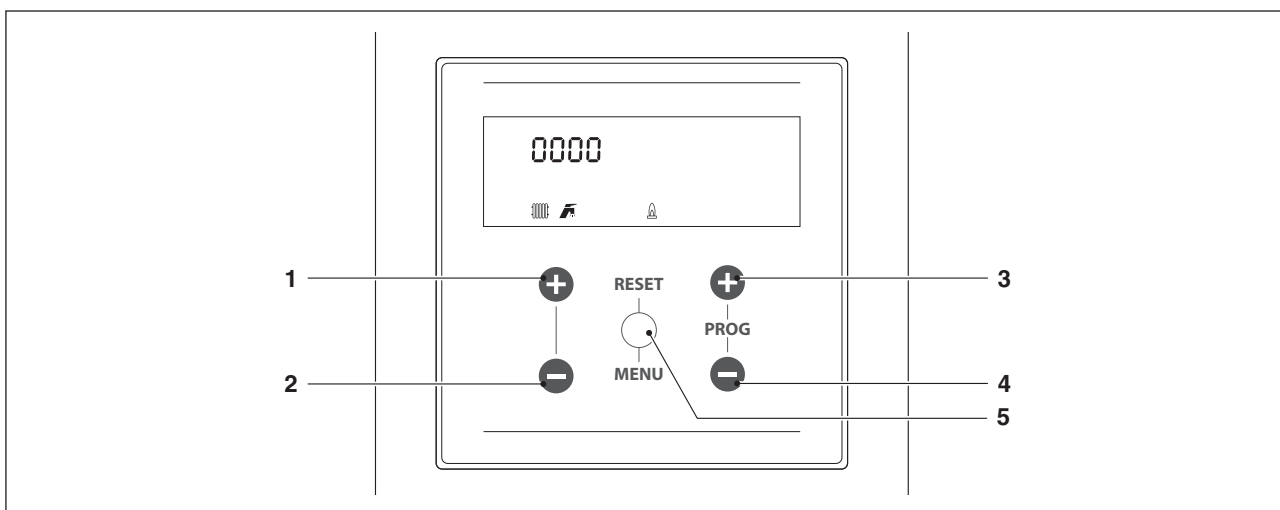

In this mode, keys have the following functions:

Nr.	Button	Function
1	"+"	Exits from the menu and cancels a parameter change
2	"-"	Exits from the menu and cancels a parameter change
3	"PROG +"	Selects the following menu or increases a certain parameter value
4	"PROG -"	Selects the previous menu or decreases a certain parameter value
5	"MENU/RESET"	Enters into the selected menu/parameter or confirms the parameter change

5.3.2 Navigation Menu INSTALLER / MANUFACTURER

It is necessary to enter the password to access the INSTALLER / MANUFACTURER parameters

- Press "MENU/RESET" and select "Code" by using the "PROG +" and "PROG -".



- Press "MENU/RESET" to confirm
- "0---" is displayed on the big numeric display and the first digit is blinking



- Press "PROG +" and "PROG -" to increase or decrease the value of the first blinking digit
- When the desired value is reached on the single figure, press "MENU/RESET" to confirm the inserted value thus the second digit starts blinking
- Repeat the same procedure for all four figures and enter the password

After entering the INSTALLER or MANUFACTURER password, the related menu and parameters will be displayed.

The system provides for three types of access:

- USER: password 0000
- INSTALLER: password 0300
- MANUFACTURER

! After it is entered, the password is active during display and/or parametrisation. If the display is inactive for a few minutes, it needs to be re-entered.

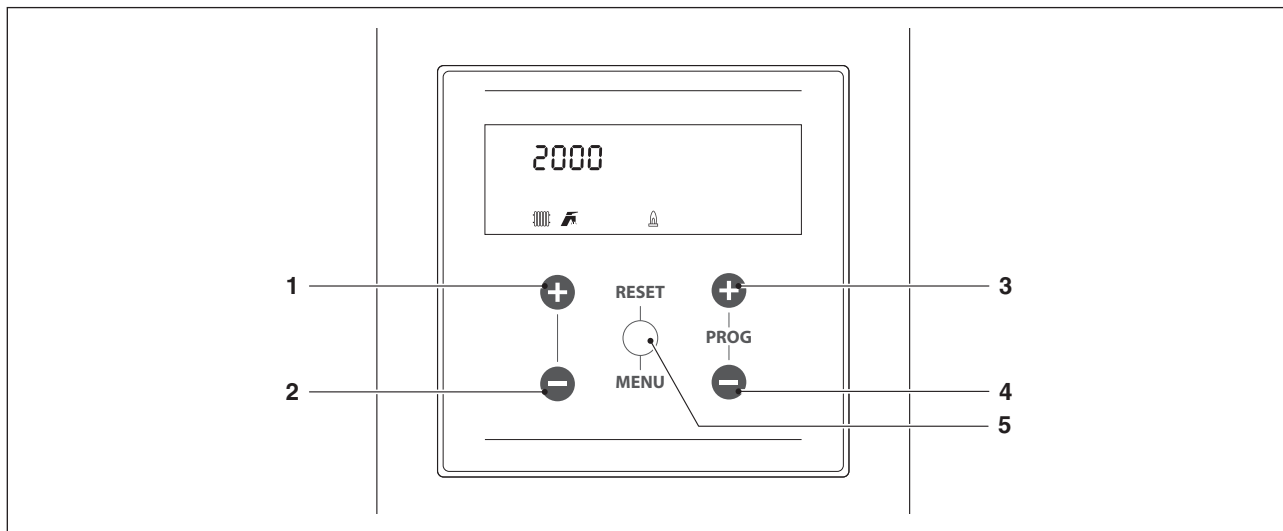

In this mode, keys have the following functions:

Nr.	Button	Function
1	"+"	Exits from the menu and cancels a parameter change
2	"-"	Exits from the menu and cancels a parameter change
3	"PROG +"	Selects the following menu or increases a certain parameter value
4	"PROG -"	Selects the previous menu or decreases a certain parameter value
5	"MENU/RESET"	Enters into the selected menu/parameter or confirms the parameter change

5.4 Parameters specific to cascade systems

Parameters are listed base on the reference menu.

Reference Menu

M1	Parameters Menu
M2	Cascaded module configuration menu
M3	Cascaded boiler configuration menu
M4	Appliance configuration menu

Access type

U	End user
I	Installer
O	Manufacturer

Menu	Par. No.	Display visualisation	Description	Range	Default setting	UM	Access type	Category
M2	2189	Burner Address	It is used to address the module.	Stand-alone (0) Managing (1) Dependent (2...16)	Stand-alone (0)		I	DHW
M2	4194	Dip-switch Config.	Enable or disable the dipswitch function.	Enabled/Disabled	Disabled		I	Cascade
M2		Boiler demand disabled	All requests for this boiler are disabled.	Yes/No	No		I	Cascade
M2	4072	Permit Emergency Mode	Activates the emergency mode. This mode comes on when communication between Managing and the primary circuit's probe is lost. In this event, if Par. 4072 is set to "Yes", the cascade is initiated, working to the fixed set-point determined by Par. 4074.	Yes/No	Yes		U	Cascade
M2	4074	Emergency Set-point	Set-point active in emergency mode.	20...90	70	°C	I	Cascade
M2	4075	Delay Per Start Next Mod.	Defines the stand-by time in seconds to restart the subsequent cascade module in normal start mode.	5...255	120	Sec.	I	Cascade
M2	4076	Delay Per Stop Next Mod.	Defines the stand-by time in seconds to switch off the last cascade module on in normal Off mode.	5...255	30	Sec.	I	Cascade
M2	4142	Delay Quick Start Next	Defines the stand-by time in seconds to restart the next cascade module in quick start mode.	5...255	60	Sec.	I	Cascade
M2	4143	Delay Quick Stop Next	Defines the stand-by time in seconds to switch off the last cascade module on in Quick Stop mode.	5...255	15	Sec.	I	Cascade
M2	4077	Hyst. Down Start Module	Defines by how many degrees the temperature measured by the primary circuit's probe must fall below the set-point in order for the subsequent module to be started after the time interval set by Par. 4075.	0...40	5	°C	I	Cascade
M2	4078	Hyst. Up Stop Module	Defines by how many degrees the temperature measured by the primary circuit's probe must go above the set-point in order for the subsequent module to be switched off after the time interval set by Par. 4076.	0...40	4	°C	I	Cascade
M2	4144	Hyst. Down Quick Start	Defines by how many degrees the temperature measured by the primary circuit's probe must go below the set-point in order for the subsequent module to be started after the time interval set by Par. 4142 (quick-start mode).	0...40	20	°C	I	Cascade

Menu	Par. No.	Display visualisation	Description	Range	Default setting	UM	Access type	Category
M2	4145	Hyst. Up Quick Stop	Defines by how many degrees the temperature measured by the primary circuit's probe must go above the set-point in order for the subsequent module to be switched off after the time interval set by Par. 4143 (quick stop mode).	0...40	6	°C	I	Cascade
M2	4146	Hyst. Up Stop All	Defines by how many degrees the temperature measured by the primary circuit's probe must go above the set-point in order for all "On" modules to be switched off at the same time.	0...40	8	°C	I	Cascade
M2	4147	Number of Units	Defines the number of modules of which the cascade consists.	1...16	8		I	Cascade
M2	4148	Power Mode	Defines the cascade operation mode. 0 = Disabled 1 = Min burners 2 = Max burners	0,1,2	2		I	Cascade
M2	4079	Max. Setp. Offset Down	Defines the maximum decrease in the primary circuit's cascade set-point. Is based on the primary circuit's probe reading.	0...40	2	°C	I	Cascade
M2	4080	Max. Setp. Offset Up	Defines the maximum increase in the primary circuit's cascade set-point. Is based on the primary circuit's probe reading.	0...40	5	°C	I	Cascade
M2	4081	Start Mod. Delay Fact.	Defines the time in minutes from the moment the demand is triggered until the activation of the set-point increases or decreases provided for by Par. 4079 e 4080.	0...60	60	Min.	I	Cascade
M2	4082	Next Module Start Rate	It defines the minimum power for at least one of the modules in the cascade in order for the next module to be switched on (if the other conditions linked to Par. 4075 and 4077 are met).	10...100	80	%	I	Cascade
M2	4083	Next Module Stop Rate	It defines the maximum power for all the modules in the cascade in order for the last module on to be switched off (if the other conditions linked to Par. 4076 and 4078 are met).	10...100	25	%	I	Cascade
M2	4084	Module Rotation Interval	It defines the time interval (in days) after which modules are rotated.	0...30	1	Days	I	Cascade
M2	4149	First Module to Start	Establishes the number of the next module to be rotated (this value is automatically updated at each rotation).	1..16	1		I	Cascade
M2	4086	PID P	Defines the proportional term to change the setpoint of the cascade module.	0...1275	50		O	Cascade
M2	4087	PID I	Defines the integral term to change the setpoint of the cascade module.	0...1275	500		O	Cascade
M2	4150	PID Slew Rate Up	Defines the speed (in °C/100 ms) with which the set-point of individual modules is increased in the event the primary circuit's set-point is not achieved (if the value is set to zero, the change is controlled by the PI of Par. 4086 and 4087 without restrictions).	0...25.5	1		O	Cascade
M2	4151	PID Slew Rate Dn	Defines the speed (in °C/100 ms) with which the set-point of individual modules is decreased in the event the primary circuit's set-point is exceeded (if the value is set to zero, the change is controlled by the PI of Par. 4086 and 4087 without restrictions).	0...25.5	1		O	Cascade
M2	4152	Pwr-Mode2 Min Power	Defines the power value (in percentage terms) against which the average power of all on modules in cascade operation mode must be compared (Par. 4148 = 2).	0...100	20	%	I	Cascade
M2	4153	Pwr-Mode2 Hysteresis	Defines the extra power value (in percentage terms) compared to the average power of all on modules in cascade operation mode (Par. 4148 = 2).	0...100	40	%	I	Cascade

Menu	Par. No.	Display visualisation	Description	Range	Default setting	UM	Access type	Category
M2	4154	Post-Pump Period	Defines overrun time in seconds at the end of the cascade heat demand.	0...255	60	Sec.	I	Cascade
M1	4155	Frost Protection	This defines the temperature (detected by the primary sensor) below which the module pump and the system pump (with cascade configuration) are activated. If the temperature of the primary sensor falls below the value set by Par. 4155 by another five degrees, then a request is generated that turns on the cascade. When the temperature of the primary sensor reaches the value defined by Par.4155 increased by 5 degrees, then the request ceases and the cascade returns to stand-by mode.	10...30	15	°C	I	General
M2	2184	N. active burner in DHW	With this setting it is possible to set the number of burners that are used for cascade DHW.	0...16	16		I	Cascade
M2	2205	Dep. Zone Control	Enables the control of the additional heating zone managed by the Dependent module. 0 = Disabled 1 = Enabled	0...1	0		U	General
M3	5073	Boiler Address	Defines the way in which the boiler is managed.	Managing, Stand-alone, Dependent	Stand-alone		I	Cascade
M3	5156	Permit Emergency Mode	Enable/disable emergency mode.	Yes/No	Yes		U	Cascade
M3	5156	Emergency Set-point	Defines the emergency mode setpoint.	20...90	70	°C	I	Cascade
M3	5156	Delay Per Start Next Blr.	This defines the waiting time in seconds for the next cascade to start up in normal start mode.	0...1275	1275	Sec.	I	Cascade
M3	5156	Delay Per Stop Next Blr.	This defines the waiting time in seconds for the last switched-on cascade to switch off in normal off mode.	0...1275	1275	Sec.	I	Cascade
M3	5156	Delay Quick Start Next	This defines the waiting time in seconds for the next cascade to start up in quick start mode.	0...1275	400	Sec.	I	Cascade
M3	5156	Delay Quick Stop Next	This defines the waiting time in seconds for the last switched-on cascade to switch off in quick off mode.	0...1275	240	Sec.	I	Cascade
M3	5156	Hyst. Down Start Boiler	"reserved"	0...40	5	°C	I	Cascade
M3	5156	Hyst. Up Stop Boiler	"reserved"	0...40	2	°C	I	Cascade
M3	5156	Hyst. Down Quick Start	"reserved"	0...40	10	°C	I	Cascade
M3	5156	Hyst. Up Quick Stop	"reserved"	0...40	4	°C	I	Cascade
M3	5156	Hyst. Up Stop All	"reserved"	0...60	8	°C	I	Cascade
M3	5167	Number of boilers	This defines the number of boilers connected (cascade of cascades).	1...16 (basic cascade) 1...8 (full cascade)	1		I	Cascade
M3	5168	Power Mode	"reserved"	0 = Disabled 2 = Max burners 3 = Balanced burners	2		I	Cascade

Menu	Par. No.	Display visualisation	Description	Range	Default setting	UM	Access type	Category
M3	5169	Max. Setp. Offset Down	Defines the maximum decrease in the primary circuit's cascade set-point. Is based on the secondary circuit's probe reading.	0...40	2	°C	I	Cascade
M3	5170	Max. Setp. Offset Up	Defines the maximum increase in the primary circuit's cascade set-point. Is based on the secondary circuit's probe reading.	0...40	5	°C	I	Cascade
M3	5171	Start Mod. Delay Fact.	Defines the time in minutes from the moment the request is triggered until the activation of the set-point increases or decreases provided for by Par.5169 e 5170.	0...60	40	Min.	I	Cascade
M3	5172	Next Boiler Start Rate	"reserved"	10...100	80	%	I	Cascade
M3	5173	Next Boiler Stop Rate	"reserved"	10...100	25	%	I	Cascade
M3	5174	Module Rotation Interval	"reserved"	0...30	5	Days	I	Cascade
M3	5175	First Boiler to Start	"reserved"	1...8	-		I	Cascade
M3	5176	PID P	Defines the proportional term to change the set-point of the cascade module based on the secondary circuit's temperature.	0...1275	25		O	Cascade
M3	5177	PID I	Defines the integral term to change the set-point of the cascade module based on the secondary circuit's temperature.	0...1275	1000		O	Cascade
M3	5178	PID Slew Rate Up	Defines the speed (in °C/100 ms) with which the set-point of individual modules is increased in the event the secondary circuit's set-point not reached (if the value is set to zero, the change is controlled by the PI of Par. 5176 and 5177 without restrictions).	0...25.5	1		O	Cascade
M3	5179	PID Slew Rate Dn	Defines the speed (in °C/100 ms) with which the set-point of individual modules is decreased in the event the primary circuit's set-point is exceeded (if the value is set to zero, the change is controlled by the PI of Par. 5176 and 5177 without restrictions).	0...25.5	1		O	Cascade
M3	5180	Pwr-Mode2 Min Power	"reserved"	0...100	20	%	I	Cascade
M3	5181	Pwr-Mode2 Hysteresis	"reserved"	0...100	40	%	I	Cascade
M3	5182	Post-Pump period	"reserved"	0...255	30	Sec.	I	Cascade

5.5 Setting the main parameters

Some parameters are essential in order for the system to operate in cascade and setting these parameters is a determining factor for correct system operation.

5.5.1 Par.2189 – module address (burner)

Parameter 2189 sets the address with which the module (burner) is recognised and enables the primary sensor (SS).

Three values can be set:

- **Managing:** to be set on the Managing module so that primary sensor operation is activated.
N.B. Refer to the specific diagram to connect the sensor
- **Stand Alone:** to be set on the Managing module so that primary sensor operation is deactivated;
- **2 ÷ 7** to be set on all Dependent modules.

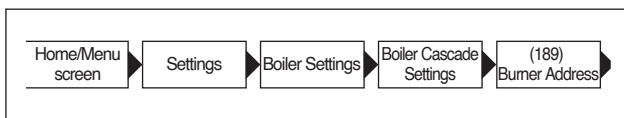

5.5.2 Par.4147 – no. of modules (burners)

Parameter 4147 is for setting the number of connected modules (burners).

This parameter must only be set on the Managing module.

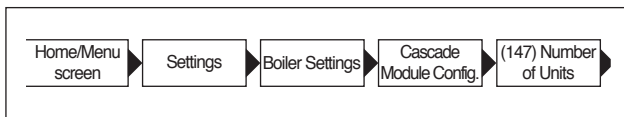

5.5.3 Par.5073 – Boiler address (cabinet)

Parameter 5073 sets the address with which the boiler (cabinet) is recognised and enables the secondary sensor (SC).

Three values can be set:

- **Managing:** to be set on the Managing module so that secondary sensor operation is activated.
N.B. Refer to the specific diagram to connect the sensor
- **Stand Alone:** to be set on the Managing module so that secondary sensor operation is deactivated;
- **2 ÷ 7** to be set on all Dependent modules.

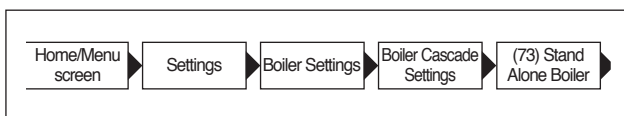

5.5.4 Par.5167 – no. of boilers (cabinets)

Parameter 5167 sets the number of connected boilers (cabinets).

This parameter must only be set on the Managing boiler.

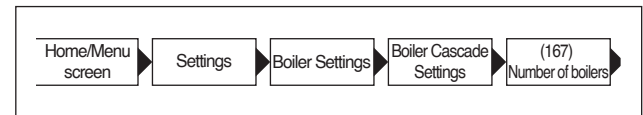

5.5.5 Par.2007 – heating setpoint hysteresis

The parameter 2007 adjust shutdown of the individual modules when the setpoint is exceeded. With cascade operation, this value must be increased (up to a maximum of 20°C) to prevent module operation from being disabled (since the default value is 5°C) if the system decides to increase the setpoint based on the value read on the primary or secondary sensor (see explanation in paragraphs "General operation", "Operation with the primary sensor" and "Operation with the secondary sensor")

This parameter is to be modified (in the same way) on all modules of the cascade (Managing module and all the relative Dependent modules).

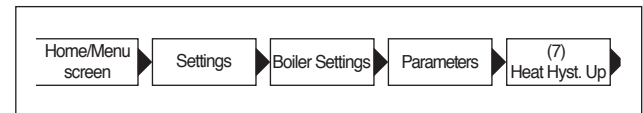

5.5.6 Par.9097 – definition of the system with circulator / system with two-way valve

The parameter 9097 serves to quickly configure the inputs and outputs on the board of each module in order to adapt operation if a circulator is present or if a two-way valve is present.

This parameter must be configured correctly on both the Dependent modules and the Managing module.

Parameter 9097 must be set to 1 if system 1 or 2 is being used (characterised by the use of the module pump), while it must be set to 2 if system 3 or 4 is being used (characterised by the use of the two-way valve).

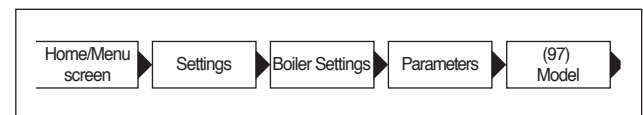

5.6 Parameter 4148: operating mode of the cascade

It is possible to adopt cascade management which can be modified according to different strategies. These different strategies can be set using the parameter known as "Cascade mode" Par. 4148.

5.6.1 Par 4148 = 0

The start-up/shutdown law of each module is based on the following graph.

The shut-off values of the lines with the y axis are the sum or the difference of the values of the corresponding parameter in relation to the value of the setpoint sent by the Managing module to the modules.

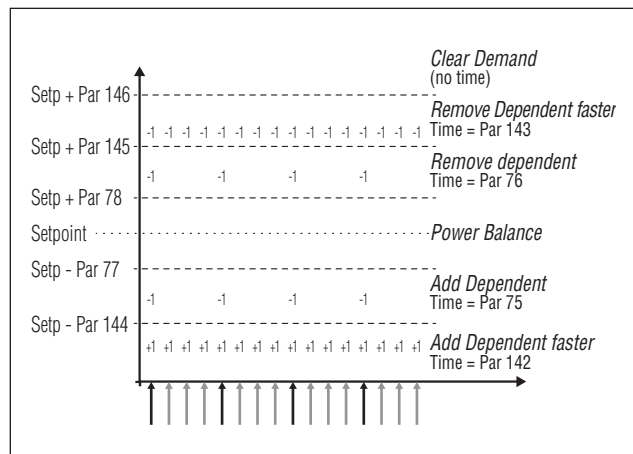

Six bands are defined on the basis of the temperature read (by the Managing module) on the delivery manifold of the primary system.

- In the central band **Power balance**, defined (by the variable parameters) around a setpoint, no start-ups or shutdowns of the Dependent modules are envisaged. The parameters which define this band are 4077 and 4078.
- In the band **Remove dependent** and **Add dependent**, the start-ups and shutdowns are carried out with "long" time intervals which can differ between start-up and shutdown. The parameters which define this band are 4077, 4078, 4144, 4145. The time interval is defined by parameters 4075 and 4076.
- In the band **Remove dependent Faster** and **Add dependent Faster**, start-ups and shutdowns are carried out with a "short" time interval which, even in this case, can differ between start-up and shutdown. The shutdown band is between the values of parameters 4146 and 4145, while the start-up band is below the value defined by parameter 4144. The time range is defined by parameters 4142 and 4143.
- In the band **Clear demand**, all the modules are immediately stopped. This band is above the value defined by parameter 4146.

5.6.2 Par 4148 = 1

In this mode the system manages the cascade so that the minimum number of modules is on.

The first difference in relation to mode 0 refers to the logic with which the modulation of Dependent modules within the cascade is managed.

While each module modulates with its own PID in mode 0, no more than two dependent modules modulate with the same criteria in mode 1, while the remaining modules operate at maximum power. The diagram is represented in the following figure:

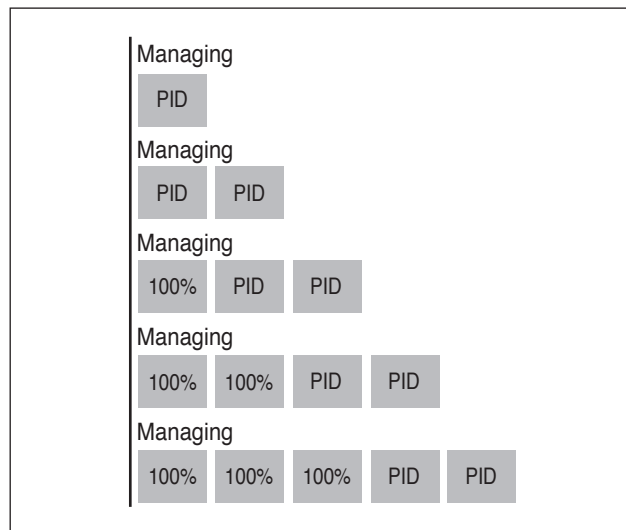

Practically speaking, if more than two modules are on, only two modules are controlled via PID, while the others receive a signal to move to maximum power.

The second difference refers to the start-up/shutdown rules of the individual modules.

In any case, the start-up and shutdown rules are managed according to the indications shown in the previous graph. The difference is that it is also possible to have start-ups/shutdowns of the Dependent modules in the "balancing" zone.

This additional start-up criteria (valid in the balancing band only) ensures that a module is started-up when any one of the two modules controlled by a PID adjustment has reached a threshold power (Par 4082) once a specific wait time defined by Par 4075 has elapsed.

Similarly (still within the balancing band), a module is shut-down if both modules controlled by a PID adjustment have reached a percentage of power which is below the minimum power threshold (Par 4083) once a specific wait time defined by Par 4075 has elapsed.

5.6.3 Par 4148 = 2

In this mode the system manages the cascade so that the maximum number of modules is on.

This mode is similar to mode 0 apart from the start-up and shutdown rules.

In this case the rules based on the information illustrated by the previous graph are still valid, with the following differences (in any case, always applicable to the "balancing" band only):

To add an additional dependent module, the managing module evaluates whether the sum of the power (calculated on the basis of the fan speed) of all the active modules is greater than the product between the number of the active dependent modules increased by one and the minimum power value (Par 4152) increased by a hysteresis value (defined by Par 4153). $[\sum(P1, P2, \dots, Pn) > (n+1) * (\text{Par 4152}) + (\text{Par 4153})]$.

To shutdown a dependent access, the managing module evaluates whether the sum of the power (calculated on the basis of the fan speed) of all the active modules is less than the product between the number of the active dependent modules and the minimum power value (Par 4152). $[\sum(P1, P2, \dots, Pn) < (n) * (\text{Par 4152})]$.

 We must consider that the percentage of power varies from a minimum of 1% and a maximum of 100% and therefore, the parameter values 4152 and 4153 are not to be taken as the percentage of absolute power.

APPENDIX

I SETTING PARAMETERS OF THE ADDITIONAL ZONE

Controls interface

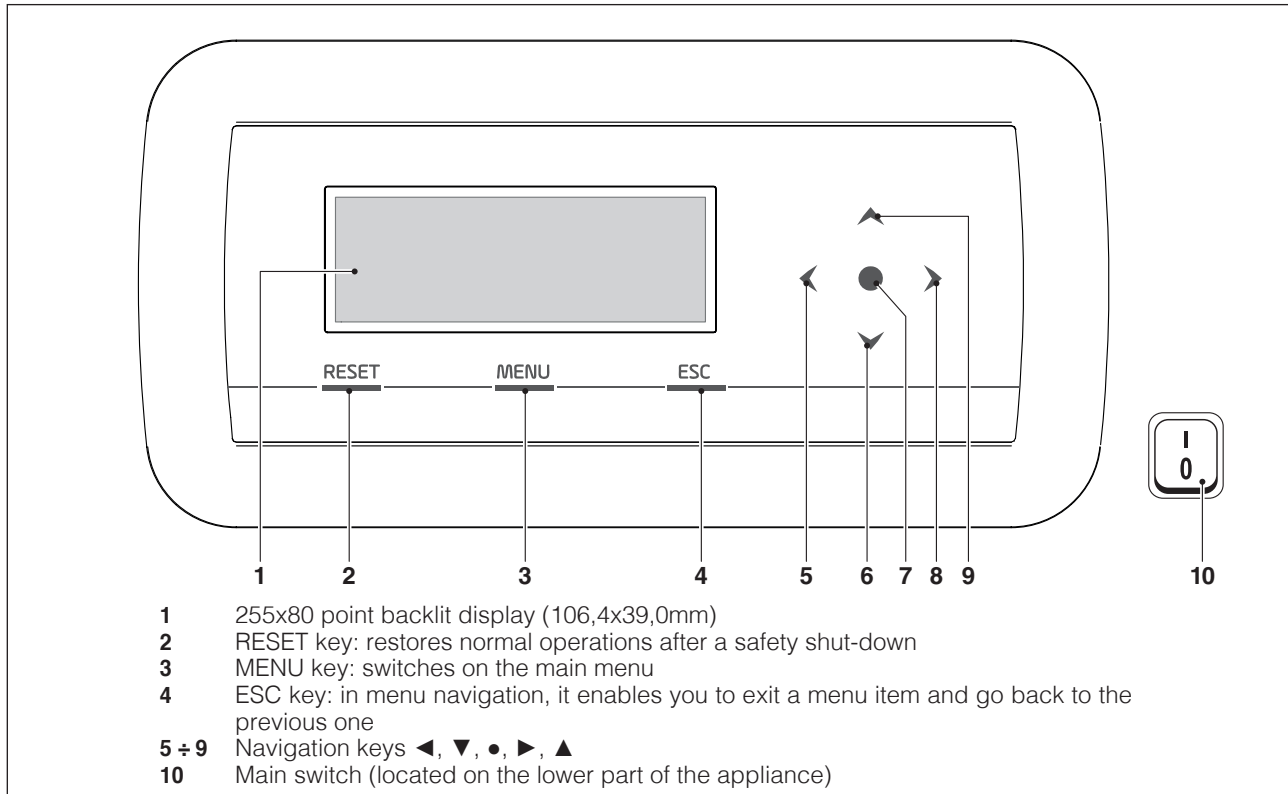

I.I Setting zone parameters (accessible only with installer password)

Menu → “Settings” → “Zone Config.”

This menu allows you to separately set the parameters of all the connected zones with the exception of the “Extra setpoint zone” which is the same for all zones.

To select the zone for controlling/changing the parameters, proceed as follows:

- press the ▶ key so that the number to the right of “zone” is highlighted;
- once the number is highlighted use the ▲ and ▼ keys to change the number of the zone;
- once the zone is selected, confirm with the ● key.

The zone parameters are the following:

Description	Standard value that is set	Range	Explanation	UM
Post-circ. Zone Pump	120	0-255	Establishes the time in seconds of the post-circulation	Secs
Mix Valve Max Op/Cl Time	25	0-255	Fixes the time in second of the total opening/closing of the mix valve (valid for three point mix valve)	Secs
Mix Valve Max steps	700	0-65535	Fixes the number of steps for the total opening of the mix valve (valid for step-by-step mix valve)	
PID zone mode	Symmetrical	Symmetrical/Asymmetrical	Fixes the PID control mode	
PID P Zone	10	0-255	Proportional parameter for the valve control	
PID I Zone	150	0-255	integrative parameter for the valve control	
PID D Zone	0	0-255	Derivative parameter for the valve control	
Extra zone set-point	10	0-30	Establishes the increase for the primary setpoint with respect to the zone setpoint	°C

⚠ For more information on navigating the commands interface (module display), see paragraph “Electronic control” of the instruction booklet of the individual appliance **POWER MAX**.

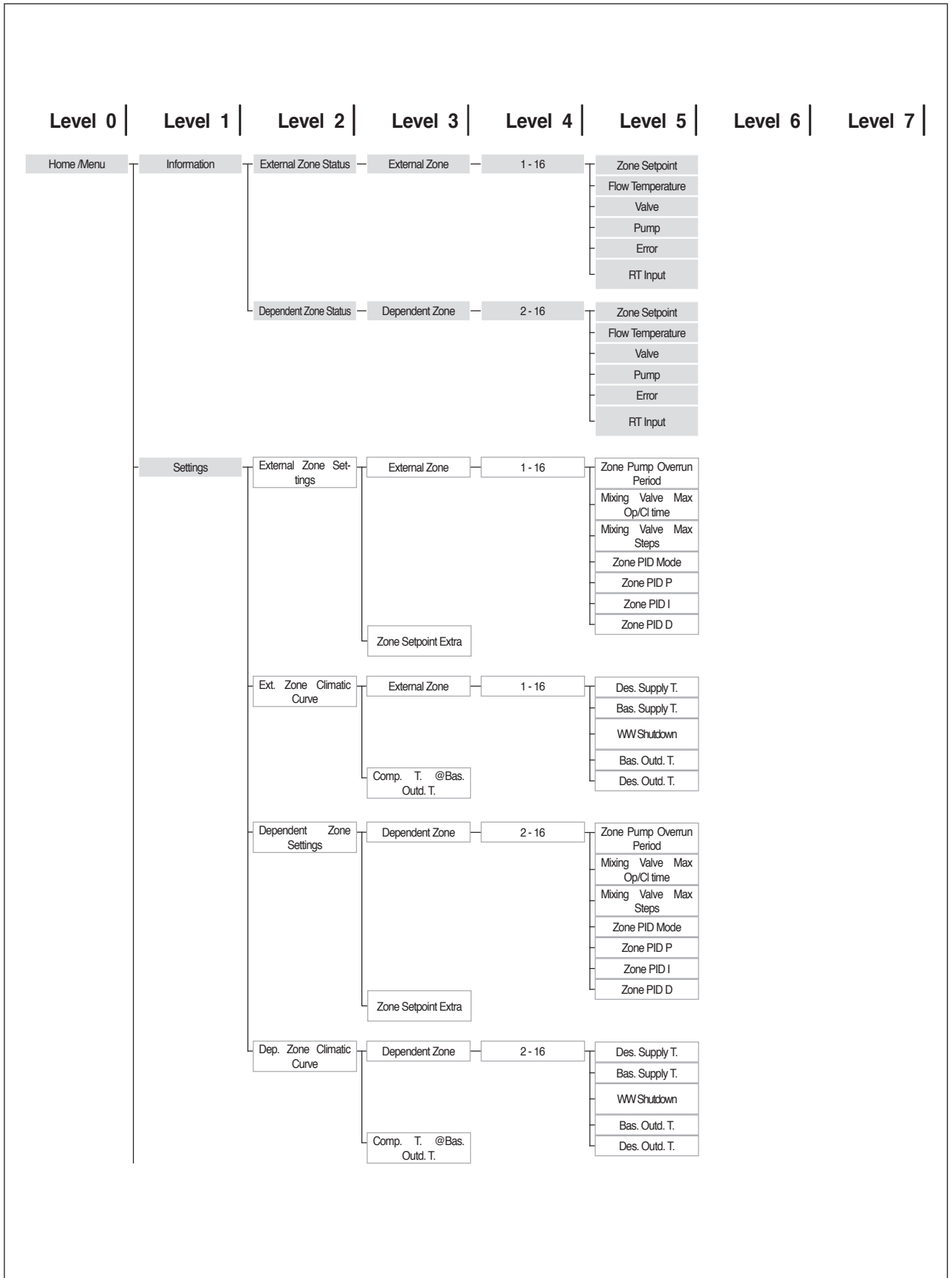

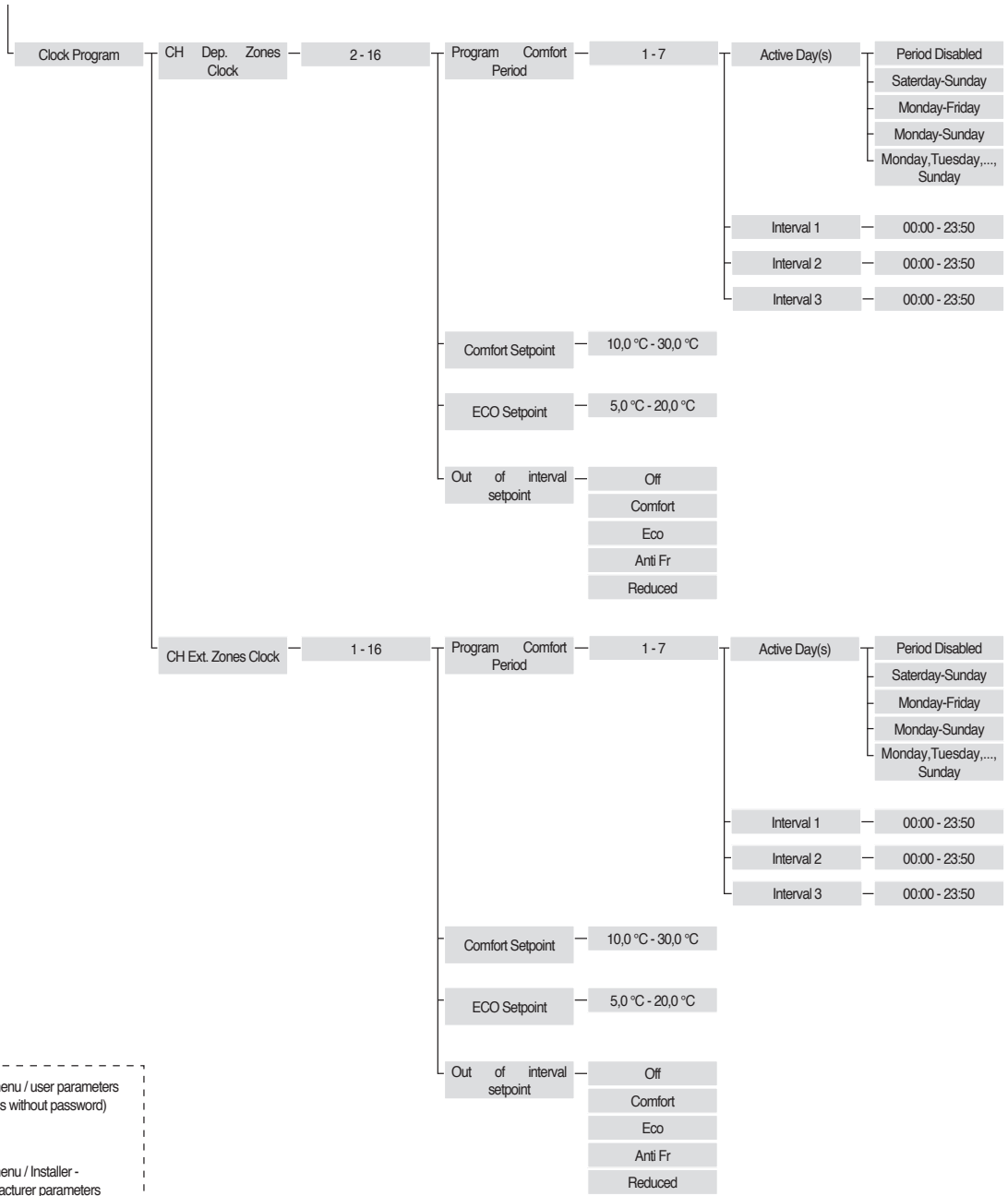

Sub-menu / user parameters
(access without password)

Sub-menu / Installer -
Manufacturer parameters
(access with password)

I.II Setting zone's climatic curve parameters (accessible only with installer password)

Menu → "Settings" → "Zone Clim. Curve"

- press the ► key so that the number is highlighted on the right of the word "Zone";
- use the ▲ and ▼ keys to change the zone number;
- press the ● key.

The following is displayed:

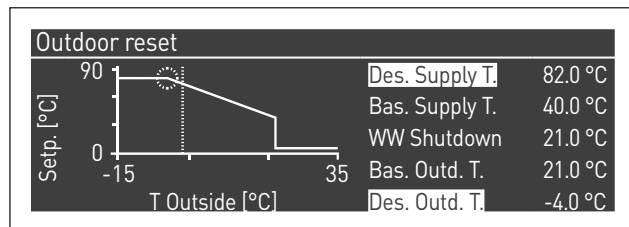

The "Comp. T. @ T.ext. Max" parameter, if other than 0, transforms the climatic curve from linear to quadratic allowing you to best adapt the variation of the setpoint to the variation of the outdoor temperature.

The resulting quadratic climatic curve will have three parameters:

- Heat. Set. Max
- Baseline Outdoor Temp.
- Text. Min

of the basic linear climatic curve and a value of the Heat. Set. Min. diminished by the value of the parameter "Comp. T. @ T.ext. Max", as can be seen in the example in the figure.

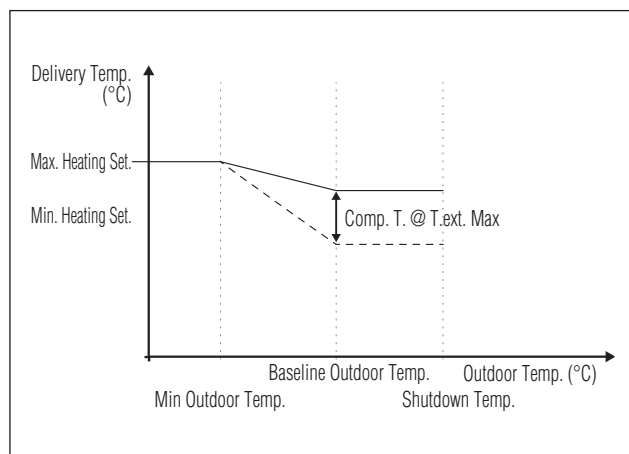

I.III Programming the zone

By default the schedule timer is disabled.

To start a request from the zone, simply close the contact of the zone request. In this case the module (or the cascade of modules) will start with a setpoint equal to the value calculated on the zone climatic curve increased by the "Zone Extra Setpoint" value and the mix valve will modulate to maintain the delivery temperature of the zone at the calculated setpoint.

To activate zone programming:

Menu → "Settings" → "Clock Settings"

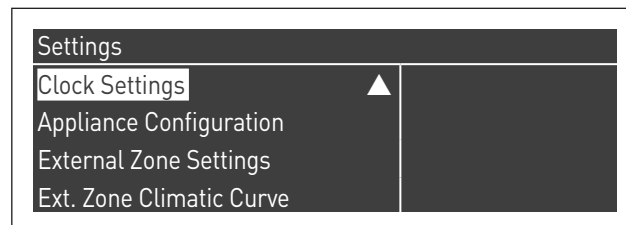

Confirming with ● the following screen is displayed:

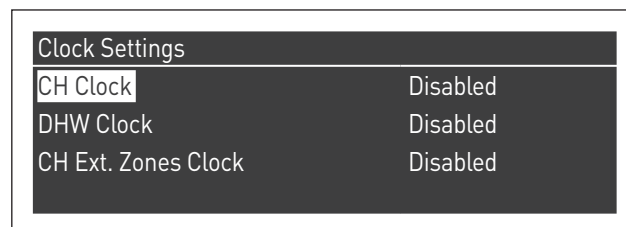

- with the ▲ / ▼ keys select "CH Zones clock"
- with the ► key move to "Disabled", change it to "Enabled" with the ▲ / ▼ keys
- confirm with the ● key

Go to:

Menu → "Clock program"

Confirming with the ● key:

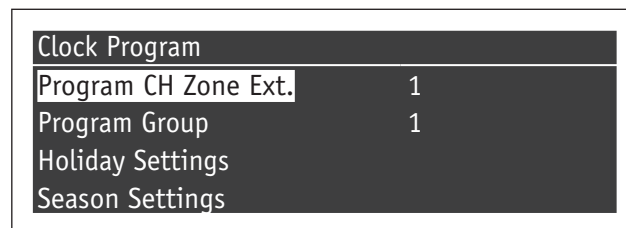

At this point select the number of the zone to be programmed and confirm with the ● key.

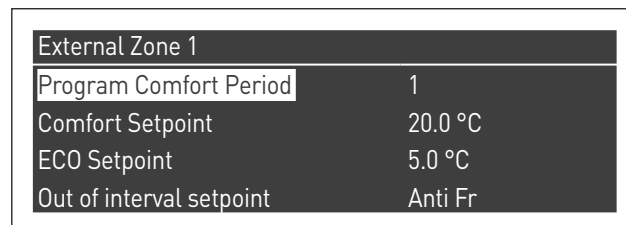

The programmable periods for each zone are 7 and they can be selected by changing the number that appears beside "Program Comfort period".

The "Comfort Setpoint" is the setpoint that is set for the area served by the zone in the active time band established within the period and can be set between ten and forty degrees.

Setting the "Comfort Setpoint" at a default of 20°C, the climatic curve that regulates the setpoint of the zone is exactly that which was set in paragraph Setting zone's climatic curve parameters (accessible only with installer password) on page 84.

By changing the "Comfort Setpoint" the climatic curve is moved upwards or downwards depending on whether the setpoint is higher or lower than 20°C. The curve will shift by two degrees for each degree of difference between the value of the setpoint and the value 20.

The "ECO Setpoint" is a setpoint that can be set between 5 and 20 degrees and can be selected as a setpoint for the area served by the zone outside the active time band.

The "Out of the interval Setpoint" defines how the zone outside the active time bands are managed (within which the setpoint of the area is always set on "comfort").

The selections for the "Out of the interval Setpoint" are the following:

- **Eco:** the ambient setpoint is set to ECO. The zone setpoint is changed by two degrees less for each degree of difference between the ECO setpoint and the value 20 (for example, if at 20° I have a setpoint of 50, at 18 degrees I have a setpoint of $50 + 2 * (18 - 20) = 46$).
- **Night-time:** the zone setpoint is lowered by 10 degrees with respect to the value of the zone setpoint set for a $T_{comfort} = 20^\circ$.
- **Antifreeze:** the ambient setpoint is set at 5°C, thereby obtaining a reduction with respect to the comfort setpoint of 30 degrees.
- **Off:** in this case the delivery of heat is interrupted.
- **Comfort:** the setpoint remains the same as that for the active time bands. This choice clearly makes no sense when scheduling is desired, but it can be useful if you want to provide heat continuously without changing the programming itself.

 So that the zone programming works the "heat request" contact should be closed. Otherwise the zone will ignore any request from the schedule timer.

I.IV Scheduling the time bands

By going to:
Menu → "Clock program" → "Zones CH Program "

External Zone 1	
Program Comfort Period	1
Comfort Setpoint	20.0 °C
ECO Setpoint	5.0 °C
Out of interval setpoint	Anti Fr

Entering in "Program Comfort Period":

External Zone 1 - Period 1		
Active Day(s)	Monday-Sunday	
Interval 1	07:10	11:00
Interval 2	00:00	00:00
Interval 3	00:00	00:00

Using the option "Active Day(s)" it is possible to select the scheduling period. You can select a day of the week or else one of these three groups of days:

- Mon-Sun
- Mon-Fri
- Sat-Sun

This facilitates weekly scheduling or else scheduling that is different during the work week and the week-end.

There are three active time bands for each period. The time resolution is 10 minutes.

I.V Information on the operation of the zone

By going to:
Menu → "Information" → "Zone Status"

External Zone Status 1	
External Zone	1

To choose the zone whose information will be displayed, proceed in the same way as in the previous paragraph.

Once the ● key is selected the following display appears:

External Zone 1	
Error	▲ 255
RT Input	No
Zone Setpoint	-10.0 °C
Flow Temperature	25.5 °C

External Zone 1	
Zone Setpoint	▲ -10.0 °C
Flow Temperature	25.5 °C
Valve	0%
Pump	Off

Via Risorgimento, 23 A
23900 - Lecco (LC)

www.berettaboilers.com

The manufacturer strives to continuously improve all products. Appearance, dimensions, technical specifications, standard equipment and accessories are therefore liable to modification without notice.

