

POWER MAX

Condensation | Heating module

EN Installation and User Manual

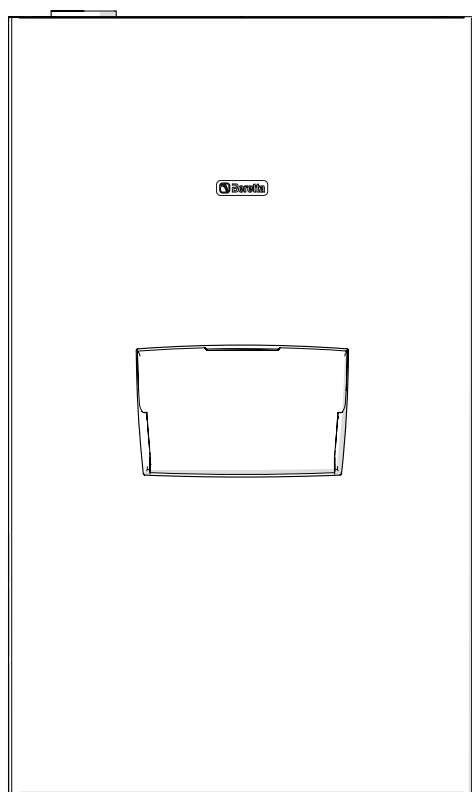

RANGE

MODEL	CODE
POWER MAX 65 P	20128431
POWER MAX 80 P	20128432
POWER MAX 100	20128433
POWER MAX 110	20128434
POWER MAX 130	20128435
POWER MAX 150	20128436

ACCESSORIES

For a complete list of accessories and details of their compatibility, refer to the Catalogue.

Dear heating engineer,
congratulations on having chosen a thermal module **Beretta**, a quality product that is designed to give dependable, efficient and safe service and to provide comfort in the home for many years to come.

This manual provides information that is essential to the installation of the appliance. Used in conjunction with your own knowledge and expertise it will enable you to install the appliance quickly, easily, and correctly.

Please accept our thanks and our congratulations on your choice of product.

Beretta

CONFORMITY

thermal modules **POWER MAX** comply with:

- Regulation (EU) 2016/426
- Directive 92/42/EEC on efficiency requirements and Annex E and Pres. Republic Decree n. 412, 26 August 1993 (****)
- Electromagnetic Compatibility Directive 2014/30/EU
- Low Voltage Directive 2014/35/EU
- Ecodesign Directive 2009/125/CE for energy-related products
- Regulation (EU) 2017/1369 Energy labelling
- Delegated Regulation (EU) N. 811/2013
- Delegated Regulation (EU) N. 813/2013
- Standard for gas-fired heating boilers - General requirements and tests - EN 15502-1
- Specific standard for type C appliances and type B2, B3 and B5 appliances of nominal heat input not exceeding 1000 kW - EN 15502-2/1
- SSIGA Gas Appliance Directive G1
- AICAA Fire prevention requirements
- CFST LPG Directive Part 2
- VARIOUS cantonal and communal provisions on air quality and energy saving.



At the end of its life, the product should be not be disposed of as solid urban waste, but rather it should be handed over to a differentiated waste collection centre.

CONTENTS

1	GENERAL INFORMATION	4	3	COMMISSIONING AND MAINTENANCE	41
1.1	General Safety Information	4	3.1	Preparing for initial startup	41
1.2	Precautions	4	3.2	Initial startup	41
1.3	Description of the appliance	5	3.2.1	Switching the appliance on and off	41
1.4	Safety devices	5	3.2.2	Password access	41
1.5	Identification	6	3.2.3	Setting the heating parameters	42
1.6	System layout	7	3.2.4	Setting the domestic hot water parameters	44
1.7	Technical specifications	9	3.3	Checks during and after initial start-up	46
1.8	Pumps	11	3.4	Error List	47
1.9	Water circuit	12	3.4.1	Permanent Errors	47
1.10	Positioning the temperature sensors	12	3.4.2	Temporary Errors	48
1.11	Control panel	13	3.4.3	Warnings	49
2	INSTALLATION	14	3.5	Transformation from one gas type to another	50
2.1	Unpacking the product	14	3.6	Adjustments	52
2.1.1	Positioning of labels	14	3.7	Temporary or short-term shut-down	53
2.2	Overall dimensions and weights	14	3.8	Preparing for extended periods of disuse	53
2.3	Installation premises	15	3.9	Display board replacement	53
2.3.1	Recommended minimum distances	15	3.10	Control board replacement	54
2.4	Installation in older systems and systems requiring modernisation	15	3.11	Maintenance	54
2.5	Moving and removing the packing	16	3.12	Cleaning and removing internal components	55
2.6	Thermal module assembly	16	3.12.1	Condensate drain siphon cleaning	58
2.7	Water connections	18	3.13	Troubleshooting	59
2.8	Typical water system schematics	19	4	SYSTEM MANAGER	60
2.9	Gas connections	22	4.1	Putting into service	60
2.10	Discharge of combustion products	22	4.2	Temporary or short-term shut-down	61
2.10.1	Preparation for the condensate drain	25	4.3	Preparing for extended periods of disuse	61
2.11	Neutralising the condensate	25	4.4	Cleaning	61
2.11.1	Water quality requirements	25	4.5	Maintenance	61
2.12	System filling and emptying	26	4.6	Useful information	62
2.12.1	Filling	26	5	RECYCLING AND DISPOSAL	63
2.12.2	Emptying	27			
2.13	Wiring diagram	28			
2.14	Electrical connections	30			
2.15	Menu navigation	33			
2.15.1	USER navigation MENU	33			
2.15.2	Navigation Menu INSTALLER / MANUFACTURER	35			

The following symbols are used in this manual:













CAUTION! = Identifies actions that require caution and adequate preparation.





STOP! = Identifies actions that you MUST NOT do.

1 GENERAL INFORMATION

1.1 General Safety Information















-  After removing the packaging, check the condition and completeness of the supply. If there are any problems, contact the company **Beretta** that sold the equipment.
-  This product must be installed by a legally qualified heating engineer. On completion of the installation, the installer must issue the owner with a declaration of conformity confirming that the installation has been completed to the highest standards in compliance with the instructions provided by **Beretta** in this instruction manual, and that it conforms to all applicable laws and standards.
-  This product must only be used for the purpose for which it is designed and made, as specified by **Beretta**. **Beretta** declines all responsibility, contractual or other, for damage to property or injury to persons or animals caused by improper installation, adjustment, maintenance or use.
-  In the event of a water leak, disconnect the thermal module from the main power supply, shut off the water supply and promptly notify the Technical Assistance Centre **Beretta** or professionally qualified personnel.
-  Periodically check that operating pressure in the water circuit is over 1 bar but below the maximum limit specified for the boiler. If this is not the case, contact Technical Assistance Centre **Beretta** or a professionally qualified heating engineer.
-  The following operations shall be necessary if the thermal module is not used for a long period of time:
 - Switch the boiler OFF at the control panel
 - Turn the main system switch "off"
 - Close the fuel cock and heating circuit water cock
 - Drain the central heating circuit if there is any risk of freezing.
-  Maintenance must be performed on the thermal module at least once a year.
-  This manual is an integral part of the appliance and must therefore be kept with care and must ALWAYS accompany the thermal module, even when it is passed on to another owner or user or transferred to another installation. If it is lost or damaged, please contact your local Technical Assistance Centre **Beretta** for a new copy.
-  This manual must be read carefully so as to ensure the correct and safe installation, operation and maintenance of the appliance. The Owner must be adequately informed and trained on how to operate the appliance. Make sure that he/she is familiar with all the information required for safe system operation.
-  The thermal module, before being connected to the hydraulic system, the gas network, and the electrical system, may be exposed to temperatures ranging from 4°C to 40°C. After it can activate the Frost Protection function, it can be exposed to temperatures ranging from -20°C to 40° C

 Regularly check that the condensate drain is free from obstruction.

 We recommend cleaning inside the exchanger once a year, extracting jet and burner and removing any installation debris by suction. This operation should be done by personnel from the Technical Assistance Centre only.

1.2 Precautions

The operation of any appliance that uses fuel, electrical power and water demands that a number of fundamental safety precautions be respected:

-  Do not allow children or infirm persons to operate the system unsupervised.
-  It is forbidden to use electrical devices or equipment, such as switches, appliances, etc. if there is a smell of gas or un-burnt products. If so:
 - Ventilate the room, opening doors and windows
 - Close the fuel shut-off cock
 - Report the fault immediately to the **Beretta's** Technical Assistance Centre or a professionally qualified heating engineer.
-  Do not touch the boiler while barefoot or wet.
-  Any technical or cleaning activity is forbidden before disconnecting the appliance from the main power supply by switching the system's master switch and the appliance's main switch to the "OFF" position.
-  Do not tamper with or adjust the safety or control devices without prior authorisation and instructions from the manufacturer.
-  Do not plug or block the condensate drain outlet.
-  Never pull, disconnect, or twist the electrical cables coming from the appliance even if it is disconnected from the mains electricity supply.
-  Do not obstruct or restrict the vents in the room where the boiler is installed. Adequate ventilation is essential for correct combustion.
-  Do not expose the appliance to weather elements (without using the dedicated accessory). It has been designed for indoor use.
-  Do not switch off the appliance if the outdoor temperature may drop to below ZERO (frost hazard).
-  Do not leave flammable containers and substances in the room where the device is installed.
-  Do not dispose of packaging material into the environment, or leave it within the reach of children, since it can become a potential hazard. Dispose of packaging material in compliance with applicable legislation.
-  Do not activate the thermal module without water.
-  Individuals without specific qualifications and skills are not allowed not remove the thermal module's casing.

1.3 Description of the appliance

POWER MAX it is a condensing, pre-mixed thermal module consisting in a modulating thermal element.

It is available in various models, ranging from 57kW to 131kW.

Optimal combustion management supports high yields (over 109%, calculated over NVC, in condensation regime) and low polluting emissions (Class 6 pursuant to EN 15502).

The thermal module is designed for open chamber operation, but can be converted to sealed chamber operation by fitting a dedicated accessory.

The appliance in standard configuration is envisaged for indoor installation to guarantee an IPX4D protection level.



POWER MAX appliances may be cascaded to reach a maximum power of 1.12 MW.

The appliance's key technical features are

- pre-mix burner with constant air-gas ratio;
- helical exchanger, coil with smooth stainless steel pipe (twin coil for POWER MAX 65 P ÷ POWER MAX 150 models), to guarantee good corrosion resistance and ensure operation with high Δt (up to 40°C) reducing start-up times;
- power from 57 to 131 kW;
- maximum flue gas output temperature 100°C;
- microprocessor management and control with self-diagnostics, shown by means of a display, and logging of main errors;
- Anti-Frost function;
- provision for room thermostat / heat request on high or low temperature zones;
- option to manage a CH circuit and a DHW circuit with storage tank;
- high-efficiency and high residual discharge head circulator (for models up to 68kW; a circulator is available as an accessory upon request for other models);
- climate control function (available only when using the outdoor temperature sensor accessory).

1.4 Safety devices

All appliance functions are electronically controlled by a dual processor technology board approved for safety functions.

Any malfunction results in the appliance being shut down and the automatic closure of the gas valve.

The following is installed on the water circuit:

- **Safety thermostat.**
- **Flow sensor** capable of monitoring the main circuit's flow on an ongoing basis and of stopping the appliance in the event of insufficient flow.
- **Temperature probes** on delivery and return lines that measure the temperature difference (Δt) between input and output fluid and enable activation of the control.
- **Minimum pressure switch.**

The following is installed on the combustion circuit:

- **Gas solenoid** in class B+C, with pneumatic gas flow compensation depending on the suction line's air flow rate.
- **Ignition/detection electrode.**
- **Flue gases temperature probe.**



The triggering of safety devices indicates the malfunction of a potentially hazardous thermal module. Therefore, contact Technical Assistance Centre immediately. After a brief pause, it is possible to try and restart the appliance (see Paragraph "Initial startup").



Safety devices must be replaced by Technical Assistance Centre, using only original parts. Refer to the spare parts catalogue supplied with the appliance. After making the repair, check that the appliance is working properly.



The appliance must not be put in service, even temporarily, when tampered safety devices are not in operation or have been tampered with.

1.6 System layout

POWER MAX 65 P - 80 P

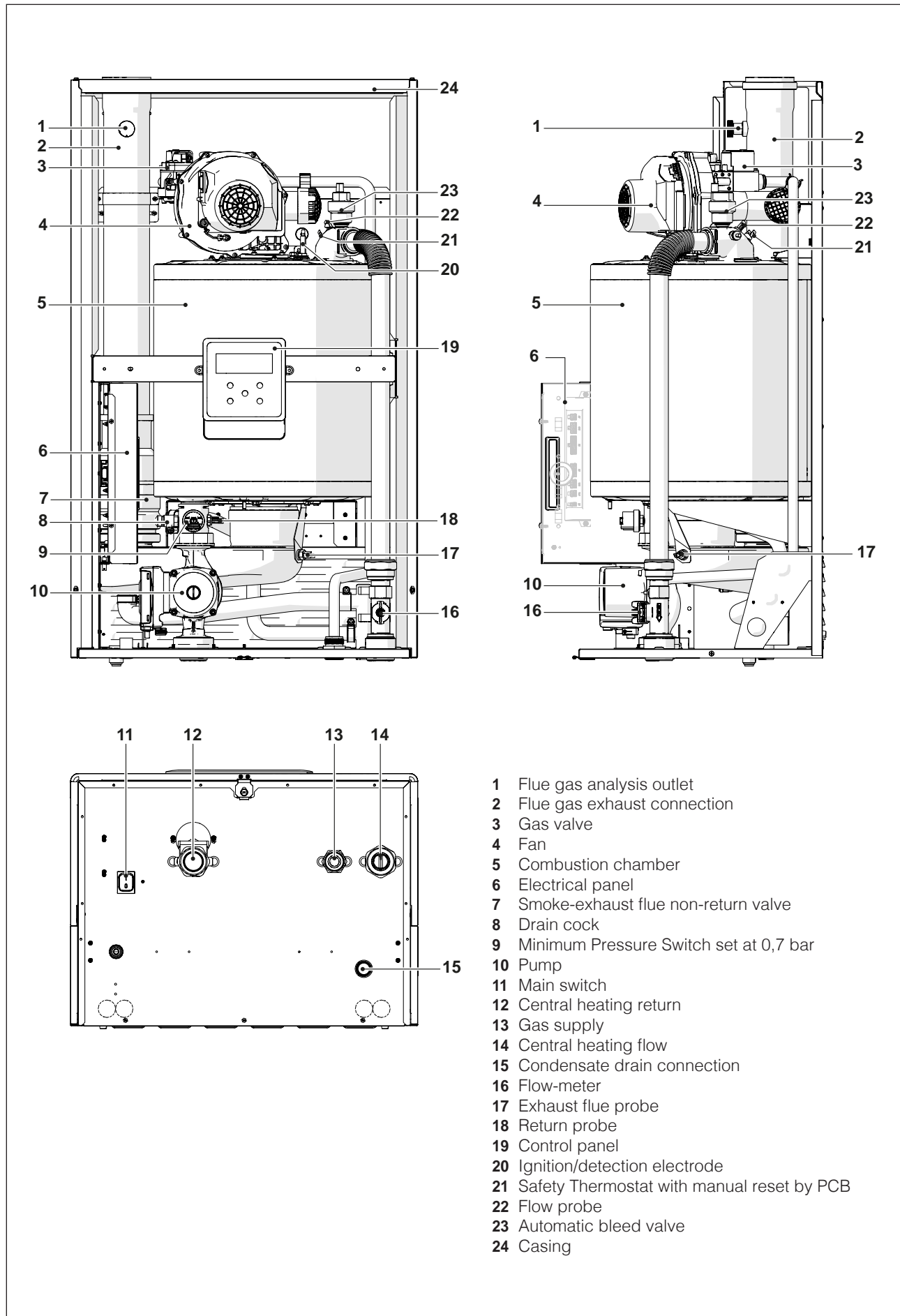

- 1 Flue gas analysis outlet
- 2 Flue gas exhaust connection
- 3 Gas valve
- 4 Fan
- 5 Combustion chamber
- 6 Electrical panel
- 7 Smoke-exhaust flue non-return valve
- 8 Drain cock
- 9 Minimum Pressure Switch set at 0,7 bar
- 10 Pump
- 11 Main switch
- 12 Central heating return
- 13 Gas supply
- 14 Central heating flow
- 15 Condensate drain connection
- 16 Flow-meter
- 17 Exhaust flue probe
- 18 Return probe
- 19 Control panel
- 20 Ignition/detection electrode
- 21 Safety Thermostat with manual reset by PCB
- 22 Flow probe
- 23 Automatic bleed valve
- 24 Casing

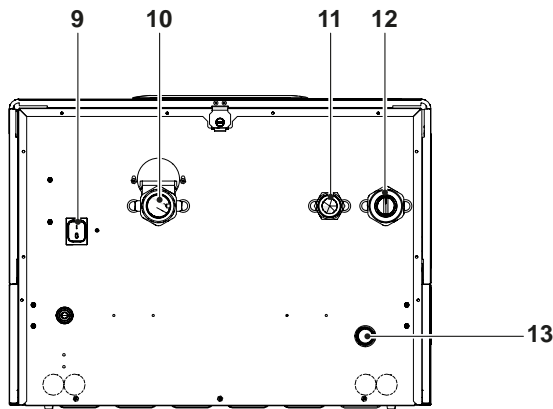
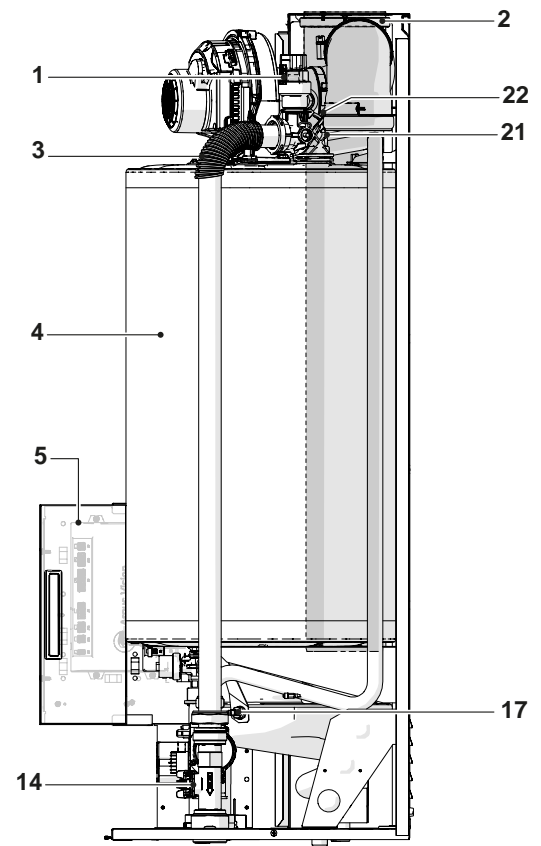
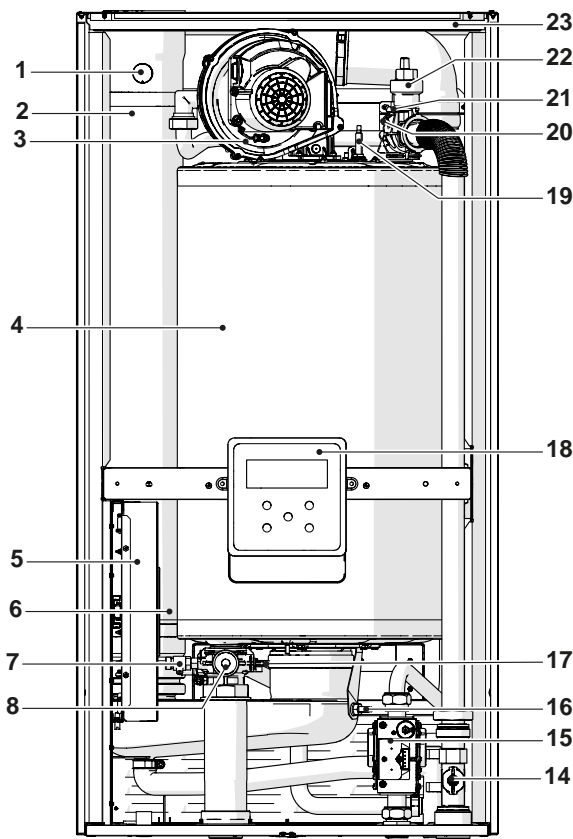

- 1 Flue gas analysis outlet
- 2 Flue gas exhaust connection
- 3 Fan
- 4 Combustion chamber
- 5 Electrical panel
- 6 Smoke-exhaust flue non-return valve
- 7 Drain cock
- 8 Minimum Pressure Switch set at 0,7 bar
- 9 Main switch
- 10 Central heating return
- 11 Gas supply
- 12 Central heating flow
- 13 Condensate drain connection
- 14 Flow-meter
- 15 Gas valve
- 16 Exhaust flue probe
- 17 Return probe
- 18 Control panel
- 19 Ignition/detection electrode
- 20 Safety Thermostat with manual reset by PCB
- 21 Flow probe
- 22 Automatic bleed valve
- 23 Casing

1.7 Technical specifications

Description	POWER MAX						U.M.		
	65 P	80 P	100	110	130	150			
Appliance type	Condensing boiler heating system B23; B53; B53P; C13*; C33*; C53*; C63*								
Fuel - Device category	IT-GB-GR-IE-PT-SI: G20=20mbar G30/G31=28-30/37mbar; II2H3+ SK: G20=20mbar G30=28-30mbar G31=37mbar; II2H3+ ES: G20=18mbar G30=28-30mbar G31=37mbar; II2H3+ BE: G20/25=20/25mbar; I2E(S) BE: G30/G31=28-30 /37mbar G31=28-30/37mbar; I3+ MT-CY-IS: G30=30mbar; I3B/P FR: G20/G25= 20/25mbar G30/G31=28-30/37mbar; II2E+3+ PL-RU: G20=20 mbar G30= 37 mbar (RU=37mbar); II2E3B/P LU: G20=20 mbar G31=37 mbar; I2E3P DE: G20/G25=20 mbar G30=50 mbar; II2ELL3B/P PL: G20=20mbar G30/G31=30mbar; II2ELwLs3P FR: G20/G25=20/25 mbar G30/G31=28-30/37mbar; II2ESi3+ FR: G20/G25= 20/25mbar G30=28-30mbar; II2ESi3B/P RO-IE-SI-BG-DK-SK-EE: G20=20mbar G30=30mbar; II2H3B/P SE-NO-LV-LT-FI-TR: G20=20mbar G30=30mbar; II2H- 3B/P HR: G20=20mbar G30/G31=30mbar; II2H3B/P HU: G20=25mbar G30=30mbar; II2H3B/P SK-CZ-LU-AT-CH: G20=20mbar G30=50mbar; II2H3B/P SI-SK: G20=20mbar G31=37mbar; II2H3P NL: G25=25mbar G30=30mbar; II2L3B/P								
Combustion chamber	vertical								
Maximum rated heat input at furnace referred to HVC (LCV)	63 (57)	76 (68)	100 (90)	108 (97)	124 (112)	146 (131)	kW		
Minimum rated heat input at furnace referred to HVC (LCV)	15 (14)	15 (14)	21,6 (19,4)	21,6 (19,4)	24,9 (22,4)	29,2 (26,2)	kW		
Useful (rated) heat output	56	68	88	95	110	129	kW		
Maximum rated heat output (80-60°C)	P4	G20	55,7	67,0	88,3	95,3	109,8	129,0	kW
Maximum nominal heat output (60-40°C)	-	G20	59,6	71,4	93,8	101,1	116,2	137,3	kW
30% heat output with return at 30°C	P1	G20	18,7	22,3	29,4	31,7	36,6	43,0	kW
Minimum rated heat output (80-60°C)	-	G20	13,5	13,5	19,2	19,2	22,1	26	kW
Efficiency class in central heating mode			A	A	-	-	-	-	
Seasonal energy efficiency in central heating mode	η_s		94	94	94	94	94	94	%
Efficiency at rated heat input and High temperature GCV (NCV) regime	η_4	useful P _n (60-80°C)	88,4 (97,7)	88,2 (98,5)	88,3 (98,1)	88,2 (98,2)	88,5 (98,0)	88,4 (98,5)	%
Efficiency at 30% of the nominal thermal flow and on low PCS temperature regime	η_1	useful 30% of P _n	98,2 (109,2)	98 (108,8)	98,1 (108,9)	98 (108,8)	98 (108,8)	98,1 (108,9)	%
Chimney losses with burner on at max. P _n (80-60°C)			2,3	2,3	2,5	2,6	2,5	2,6	%
Chimney losses with burner on at max. 30% P _n (50-30°C)			0,5	0,5	0,6	0,6	0,5	0,6	%
Heat loss in standby mode	P _{stby}		72	87	115	124	143	168	W
			0,1					%	
Annual energy consumption	QHE		117	141	-	-	-	-	GJ

(*) Accessory.

Description			POWER MAX						U.M.
			65 P	80 P	100	110	130	150	
Noise level (sound power)	LWA	at P _{max}	53	54	55	56	57	57	dB(A)
Emissions (**)	NOx	(referred to HCV)	34,2	36,4	38,1	38,7	39,3	46,1	mg/kWh
Emissions at max./min. heat input, G20	CO ₂		9 - 9 (****)						%
	CO		79/6,5	90/6,5	81/7,5	91,5/7,5	89/4,6	91,5/5,6	ppm
Maximum rated heat input (LCV)	G25		53	65	85	93	107	127	kW
Minimum rated heat input (LCV)	G25		13	13	18,1	18,5	21,4	24,5	kW
Emissions at max./min. heat input, G25	CO ₂		9 - 9						%
	CO		92/7	93,5/7	84/8	94/8	92/6	95/7	ppm
Emissions at max./min. power G30	CO ₂		10,4-10,4						%
	CO		138/10	142/10	148/11	159/11	172/13	180/15	ppm
Emissions at max./min. power G31	CO ₂		10,4-10,4						%
	CO		142/11	147/11	153/12	163/12	177/14	185/16	ppm
Gas consumption (min-max)	G20		1,43÷6,0	1,43÷7,24	2,06÷9,53	2,06÷10,29	2,37÷11,82	2,5÷13,91	mc/h
	G30		1,09÷4,58	1,09÷5,53	1,57÷7,28	1,57÷7,86	1,81÷9,02	1,91÷10,62	kg/h
	G31		1,07÷4,50	1,07÷5,43	1,54÷7,15	1,54÷7,72	1,78÷8,86	1,87÷10,43	kg/h
Flue gas temperature at max. power and min. power 80-60°C			71/61	72/61	76/62	78/62	75/61	77/61	°C
Flue gas temperature at max. power and min. power 50-30°C			45/33	46/33	47/35	49/35	45/33	48/35	°C
Flue gas mass flow rate (***)			0,025	0,03	0,04	0,046	0,05	0,06	Kg/s
Water-side resistance (ΔT 20°C)			-	-	160	210	350	510	mbar
Available useful discharge head (ΔT 20°C)			490	390	-	-	-	-	mbar
Maximum working pressure			6						bar
Minimum supply pressure			0,7						bar
Maximum permitted temperature			100						°C
Lockout thermostat activation temperature			95						°C
Adjustment temperature (min / max)			30 / 80 (****)						°C
Thermal module water content			15	15	17	17	23	25	l
Maximum condensation at 100% rated heat output (50-30°C)			8,9	10,1	13,6	15,0	17,5	19,8	l/h
Power supply			230-50						V-Hz
Index of protection			IPX4D						IP
Consumption at full load	Elmax		63	77	150	203	205	302	W
Consumption at part load	Elmin		30	30	36	31	44	45	W
Electrical consumption in stand-by mode	Psb		13	13	6	6	6	8	W

(**) Weights calculated according to EN 15502.

(***) Values referred to atmospheric pressure at sea level.

(****) Up to 85°C if combined with the plate heat exchanger accessory.

(*****) To adjust the POWER MAX 110 and POWER MAX 150 models in **Belgium, Switzerland and Hungary**, please refer to the chapter "Adjustments".

1.8 Pumps

The thermal modules POWER MAX 65 P and POWER MAX 80 P are fitted with a circulator.

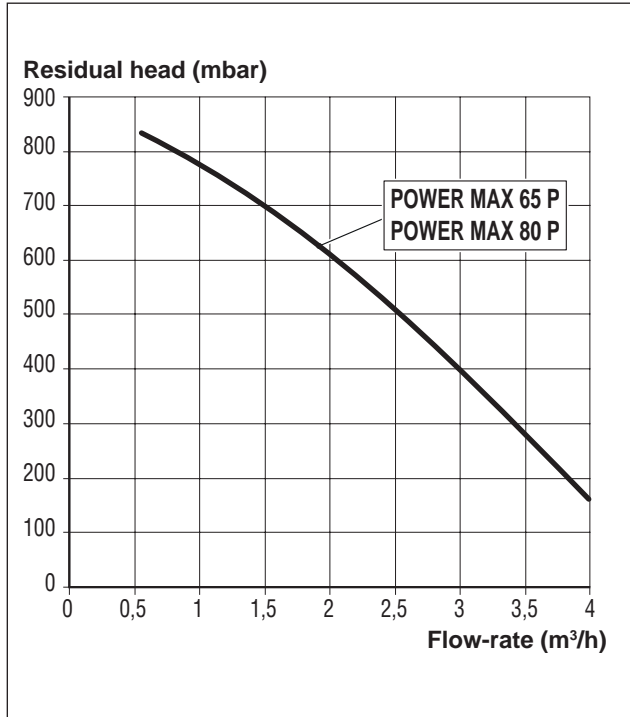

- ⚠ At the first start-up, and at least once a year, the rotation of the circulator shaft should be checked as, especially after long periods of not being operated, deposits and/or residuals could impede its free rotation.
- ⚠ Before loosening or removing the circulator cap, protect the electric devices located underneath from any water that exits.
- ⊘ It is prohibited to operate the circulators without water.

Thermal modules POWER MAX 100, POWER MAX 110, POWER MAX 130 and POWER MAX 150 are not equipped with a circulator, which must be inside or outside the appliance (see accessories).

For its sizing, consider the thermal module's water-side pressure drops, which are shown in the chart below.

Water-side pressure drop

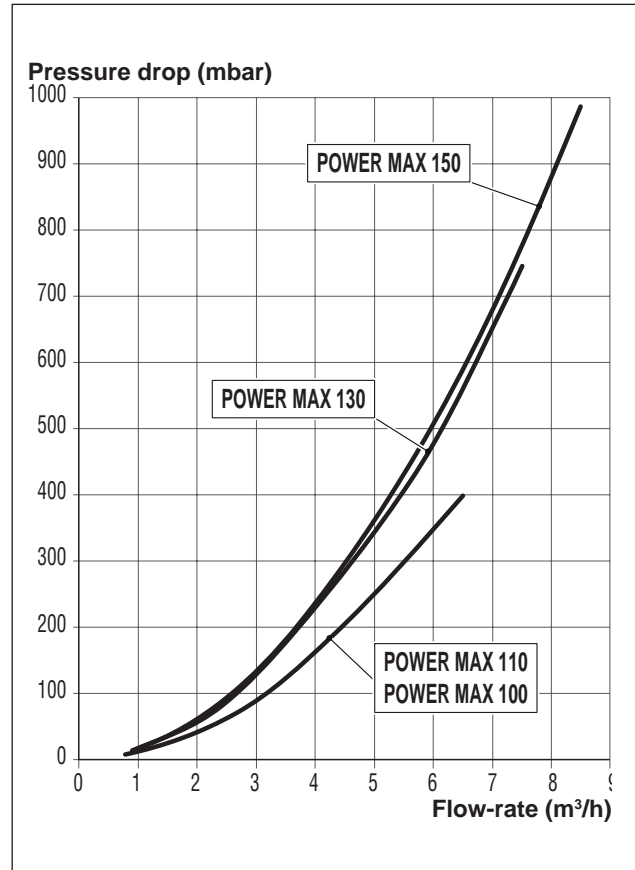

1.9 Water circuit

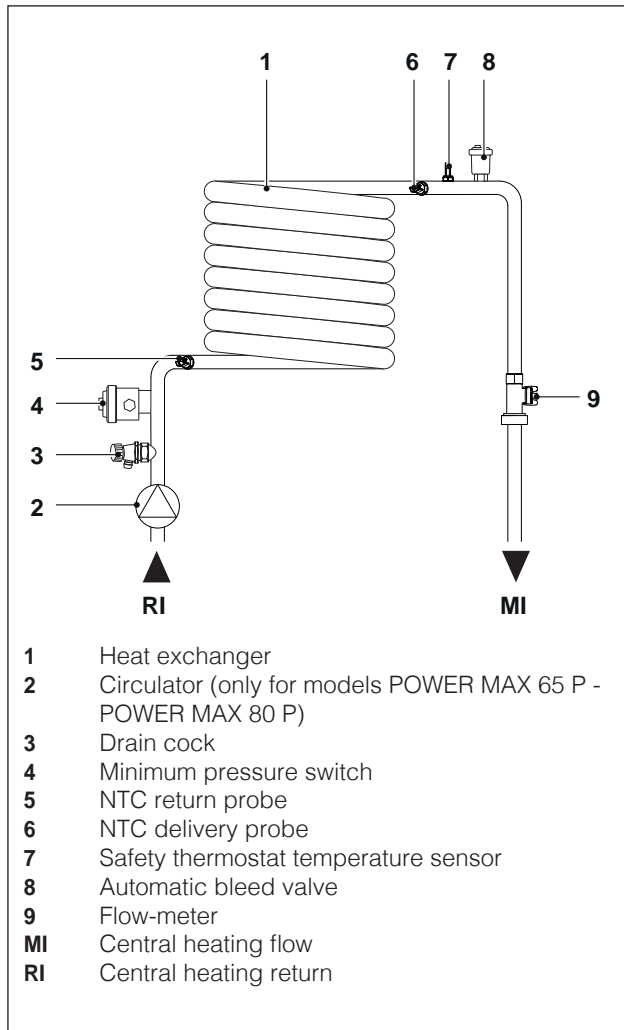

1.10 Positioning the temperature sensors

Probes placed on the related sockets of the thermal module (POWER MAX 65 P ÷ POWER MAX 150):

- 1 Exhaust flue probe
- 2 Safety thermostat
- 3 CH flow temperature sensor
- 4 Return probe

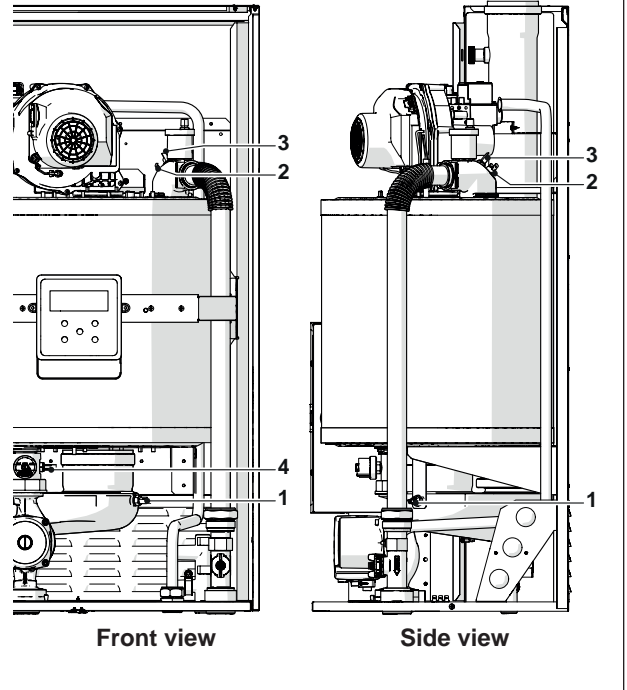

Values of NTC probes' resistors with changing temperatures.

Temperature °C Tolerance test ±10%	Resistor Ω	Temperature °C Tolerance test ±10%	Resistor Ω
-40	191908	45	4904
-35	146593	50	4151
-30	112877	55	3529
-25	87588	60	3012
-20	68471	65	2582
-15	53910	70	2221
-10	42739	75	1918
-5	34109	80	1663
0	27396	85	1446
5	22140	90	1262
10	17999	95	1105
15	14716	100	970
20	12099	105	855
25	10000	110	755
30	8308	115	669
35	6936	120	594
40	5819	125	529

1.11 Control panel

CONTROL PANEL AND SYMBOLS

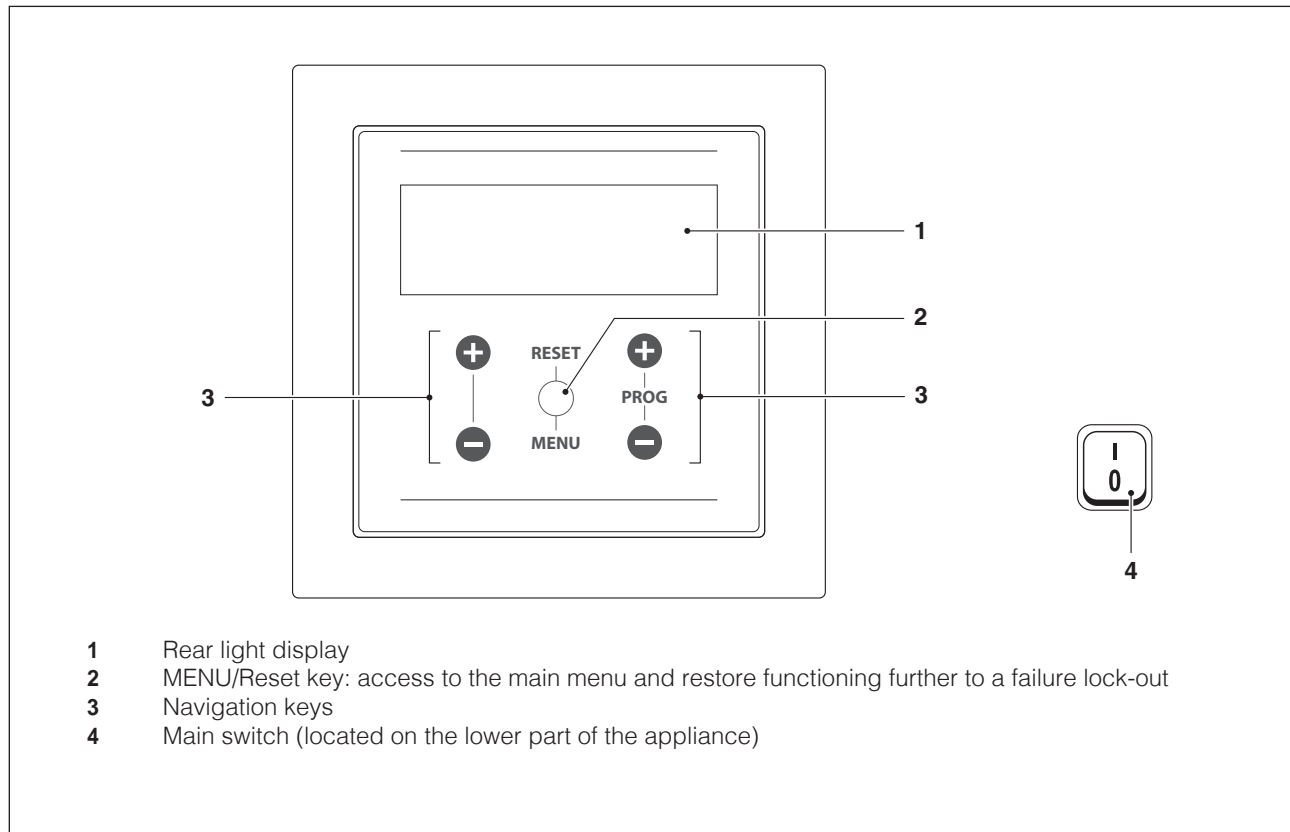

SECONDARY INFORMATION/DISPLAY VISUALISATION

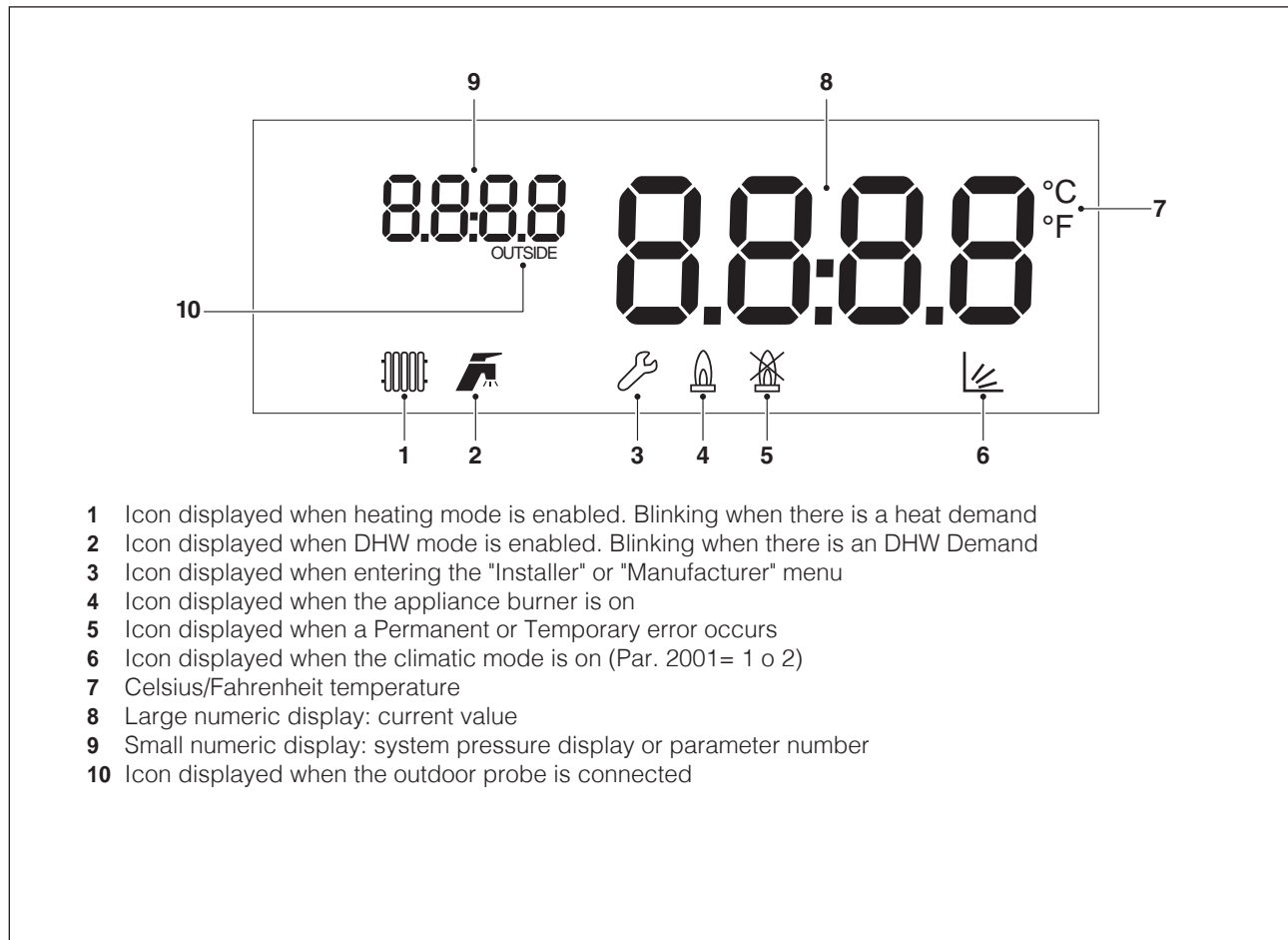

2 INSTALLATION

2.1 Unpacking the product

The thermal module **POWER MAX** is shipped palletised, packaged and with cardboard protections.

The following material is supplied in a plastic envelope inside the package (1):

- Instruction manual
- Warranty information leaflet **Beretta**
- LPG conversion kit
- Wall-mounting bracket with plugs (no.4 plugs s=10 mm suitable for concrete, brick, compact stone and concrete hollow brick walls)
- Hydraulic test certificate
- Energy Efficiency Label (for models <68kW)

2.1.1 Positioning of labels

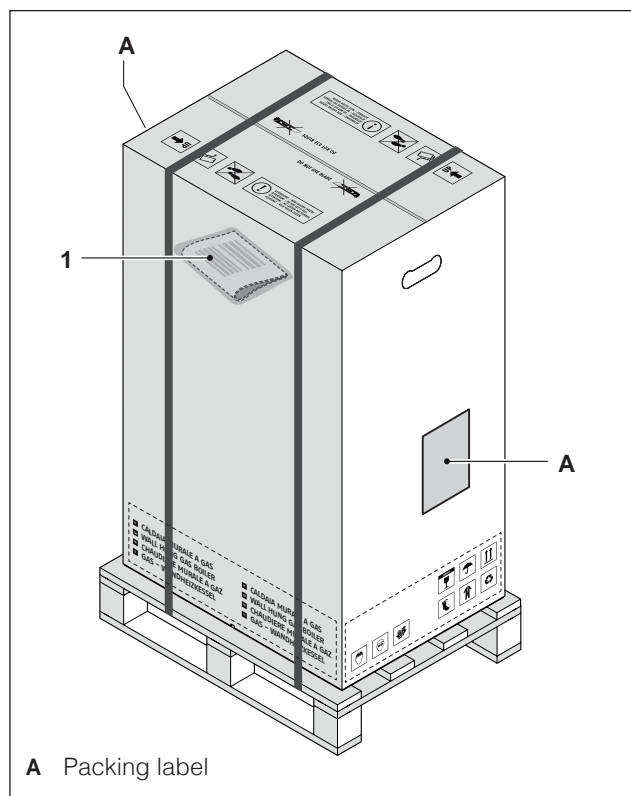

A Packing label

⚠ The instruction manual is an integral part of the appliance; therefore, it should be read and stored carefully.

⚠ Keep the documentation envelope in a safe place. Any replacement documents must be ordered from Beretta who reserve the right to charge for the cost of the replacement.

2.2 Overall dimensions and weights

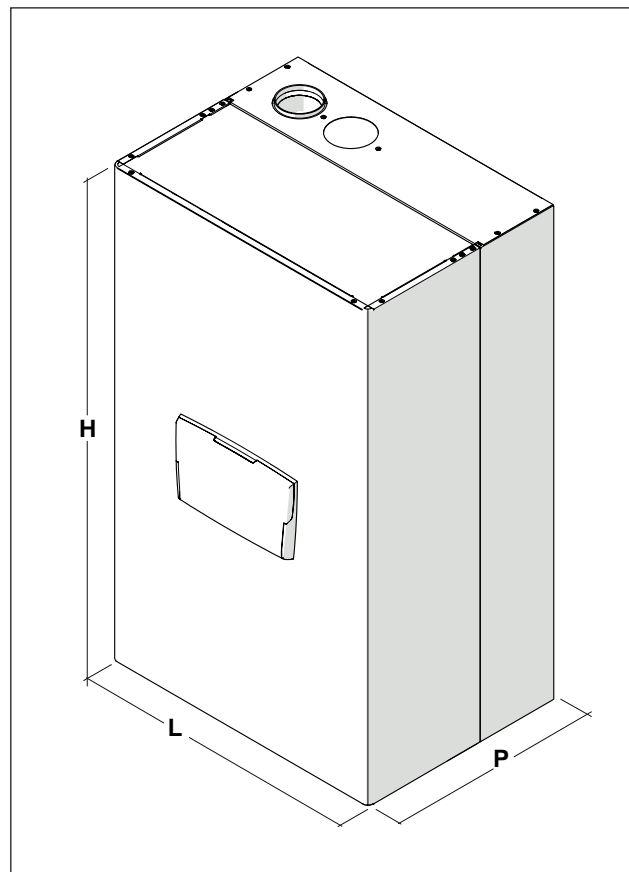





Description	POWER MAX			
	65 P	80 P	100	
L	600	600	600	mm
P	435	435	435	mm
H	1000	1000	1000	mm
Net weight	78	78	81	kg

Description	POWER MAX			
	110	130	150	
L	600	600	600	mm
P	435	435	435	mm
H	1000	1165	1165	mm
Net weight	81	93	97	kg

2.3 Installation premises

The thermal module **POWER MAX** can be installed in rooms that are permanently ventilated and equipped with suitably sized ventilation openings in line with Technical Standards and Regulations applicable to the installation site.

-  When installing the boiler, allow sufficient space around it to access all safety and control devices and to permit easy maintenance.
-  Check that the electric protection level of the appliance is suitable for features of the room where it is installed.
-  Make sure that comburent air is not contaminated by substances containing chlorine or fluorine (elements found in sprays, paints, detergents etc.).
-  Do not obstruct or restrict the air vents in the room where the boiler is installed. A free air supply is essential for correct combustion.
-  It is forbidden to leave flammable containers and substances in the room where the thermal module is installed.

2.3.1 Recommended minimum distances

Clearances for the assembly and the maintenance of the appliance are shown in the figure.

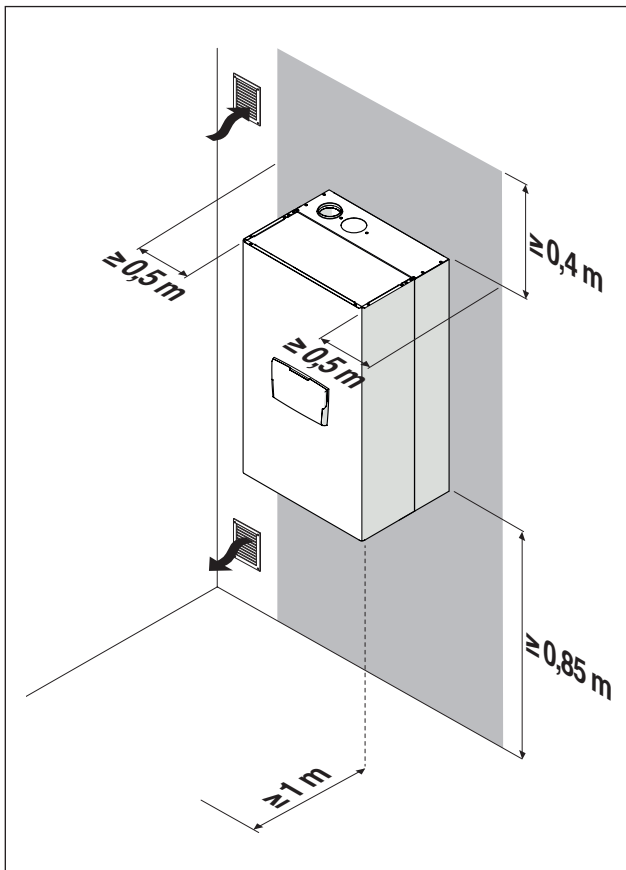

The minimum surface of ventilation openings is 3,000 cm² for gas fuel heating systems.

2.4 Installation in older systems and systems requiring modernisation

When installing these boilers in older systems or systems requiring modernisation, always perform the following checks:

- Make sure that the flue is able to withstand the temperature of the combustion gases and that it has been designed and made in compliance with applicable standards. The flue must also be as straight as possible, sealed, insulated and not blocked or choked. See Paragraph "Discharge of combustion products" for any additional information.
- Make sure that the electrical supply system has been installed by a qualified electrician in compliance with applicable standards
- Make sure that the fuel feed line and any storage tank are made and installed in compliance with applicable standards
- Make sure that expansion vessels are big enough to contain the additional volume generated by thermal expansion
- Make sure that the flow rate, head and direction of flow of the pumps are suitable and correct
- The system has been washed, cleaned of mud and grime and water seals have been checked
- A treatment system is fitted when the supply/refill water has values other than those indicated in Paragraph "Water quality requirements"

 The manufacturer declines all responsibility for damage caused by incorrectly constructed flue systems.

2.5 Moving and removing the packing

- ⚠ Do not remove the cardboard packaging until you reach the installation location.
- ⚠ Before handling the appliance and removing the packaging, wear PPE and use tools suitable for the appliance's size and weight.
- ⚠ This step must be carried out by several individuals equipped with suitable means with respect to the appliance's size. Make sure that the load is not unbalanced during handling.

Proceed as follows to remove the packing:

- Remove the strapping that secures the cardboard packaging to the pallet
- Remove the cardboard
- Remove edge protectors (1)
- Remove the Styrofoam protection (2)
- Remove the protective bag (3)

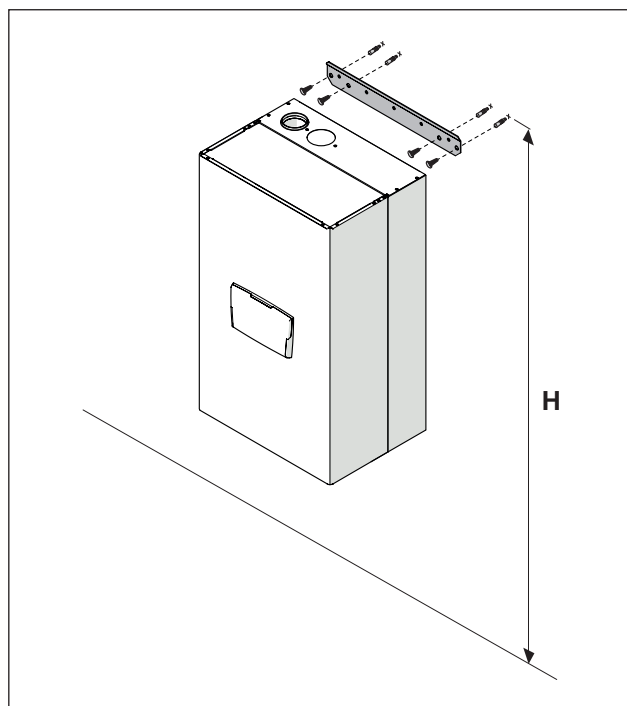
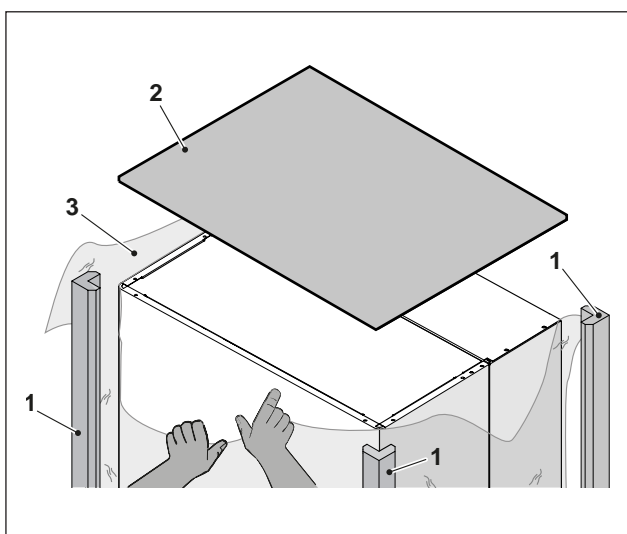

Model	Height (H) mm
POWER MAX 65 P	1850<H<2000
POWER MAX 80 P	1850<H<2000
POWER MAX 100	1850<H<2000
POWER MAX 110	1850<H<2000
POWER MAX 130	2000<H<2150
POWER MAX 150	2000<H<2150

For installation:

- Position the bracket (1) onto the wall (2), at the point where you wish to install the appliance
- Ensure that the bracket is horizontal and mark the points where the holes for fixing plugs must be drilled
- Drill the holes and insert expansion plugs (3)
- Fix the bracket to the wall using the screws (4)
- Secure the appliance onto the bracket

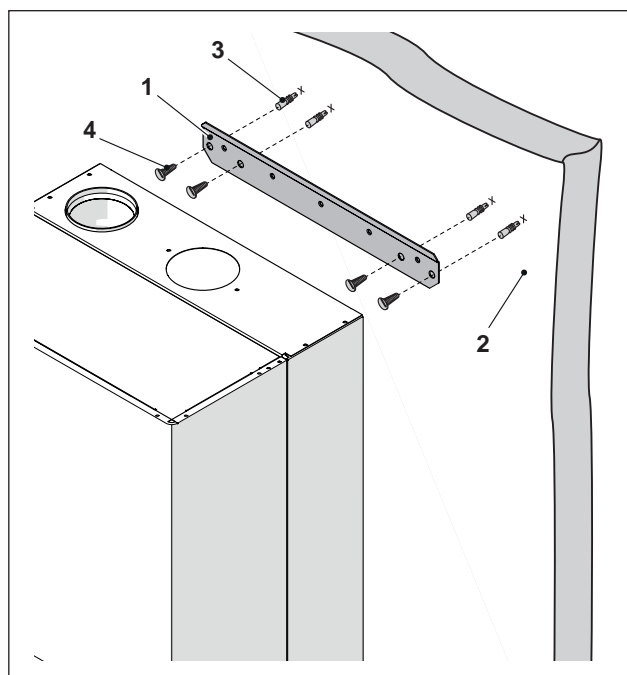

2.6 Thermal module assembly

Thermal modules **POWER MAX** are supplied complete with a wall-mounting bracket.

- ⚠ Check that the wall on which the appliance is to be fitted is sufficiently solid and supports safe screw fixing points.
- ⚠ The appliance's height must be selected so as to facilitate dismantling it and maintaining it.

After installing the thermal module:

- remove the locking screw.
- pull the front panel outwards and then to the top to decouple it from points A.

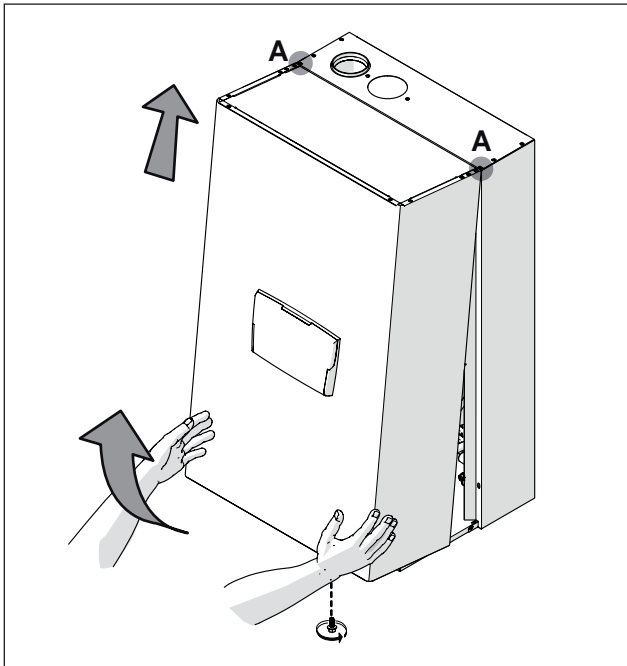

- remove the polystyrene block (B) under heat exchanger (only for models POWER MAX 100 - POWER MAX 110 - POWER MAX 130 - POWER MAX 150).

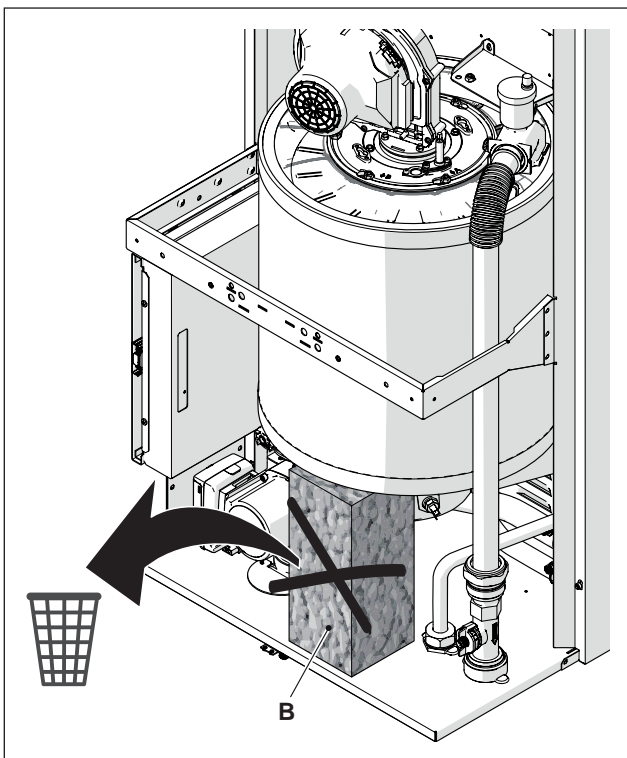

Locate the envelope containing the product documentation and stick the Energy Efficiency Label (if any) contained in the envelope onto the panel.

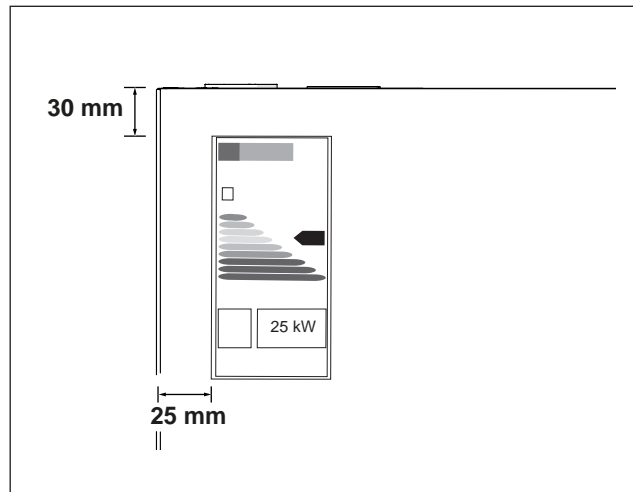

Close the panelling in reverse order to the one described above.

- ⚠ Before proceeding with the hydraulic connections the protection plugs must be removed from the delivery, return and condensate drain piping.

2.7 Water connections

The dimensions and position of thermal module's hydraulic connections are shown in the table below.

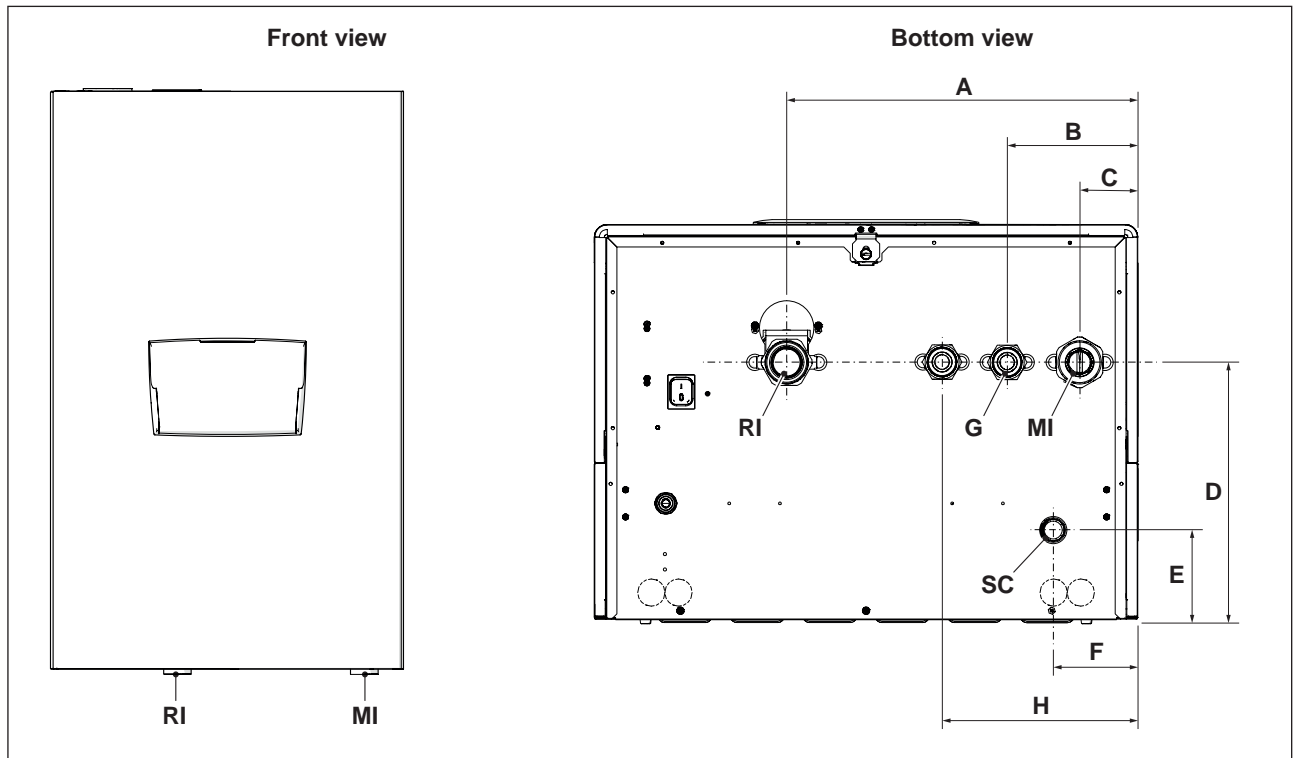

DESCRIPTION	POWER MAX						
	65 P	80 P	100	110	130	150	
A	387	387	387	387	387	387	mm
B	143,5	143,5	143,5	143,5	143,5	143,5	mm
C	63,5	63,5	63,5	63,5	63,5	63,5	mm
D	283,5	283,5	283,5	283,5	283,5	283,5	mm
E	98,5	98,5	98,5	98,5	98,5	98,5	mm
F	92,5	92,5	92,5	92,5	92,5	92,5	mm
H (optional 3-way valve attachment)	-	-	-	-	-	-	mm
MI (system flow)	G 1" 1/2 M	G 1" 1/2 M	G 1" 1/2 M	G 1" 1/2 M	G 1" 1/2 M	G 1" 1/2 M	Ø
RI (system return)	G 1" 1/2 M	G 1" 1/2 M	G 1" 1/2 M	G 1" 1/2 M	G 1" 1/2 M	G 1" 1/2 M	Ø
SC (condensate drain)	25	25	25	25	25	25	Ø mm
G (gas inlet)	G 1" M	G 1" M	G 1" M	G 1" M	G 1" M	G 1" M	Ø

⚠ Before connecting the thermal module the protection plugs must be removed from the delivery, return and condensate drain pipes.

⚠ Before connecting the thermal module, it is necessary to clean the system. This step is absolutely required when the appliance replaces another one on pre-existing systems.

In order to carry out this cleaning activity, if the old generator is still installed on the system, it is advisable to:

- add a de-scaling additive.
- Operate the system with the generator on for around 7 days.
- Discharge dirty system water and flush the system one or more times with clean water.

If the system is very dirty, repeat the last procedure one more time.

If the old generator is not present or available, use a pump to circulate the water + additive through the system for about 10 days and perform a final washing as described in the previous paragraph.

Once the cleaning has been completed, it is recommended to add a suitable protective fluid to the system's water before installing the thermal module.

In order to clean the heat exchanger's built-in water system, please contact Technical Assistance Centre **Beretta**.

⊘ Do not use incompatible liquid detergents, including acids (for instance, chloridric acid and similar) in any concentration.

⊘ Do not subject the heat exchanger to cyclical pressure changes because fatigue stress is very dangerous for the integrity of system components.

2.8 Typical water system schematics

Layout 1: circuit with thermal module directly linked to heating system (check that the pump's discharge head is sufficient to ensure adequate circulation)

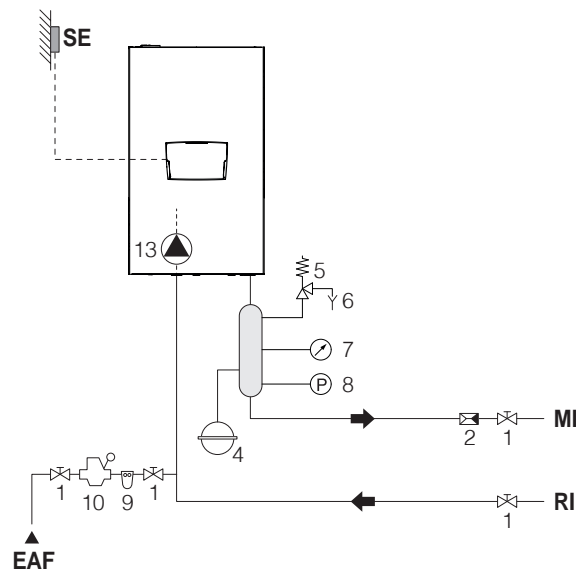

Layout 2: circuit with thermal module directly linked to heating system and DHW tank. (check that the pump's discharge head is sufficient to ensure adequate circulation)

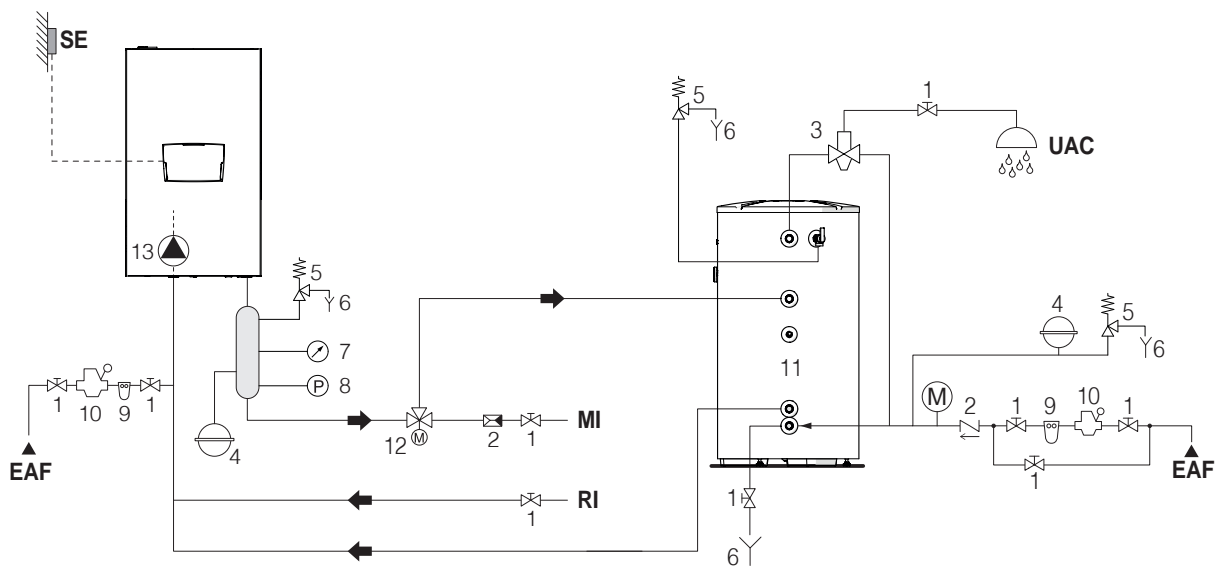

- 1 Isolating valve
- 2 Non-return valve
- 3 Anti-scald mixer valve
- 4 Expansion tank
- 5 Safety valve
- 6 Drain
- 7 Pressure gauge
- 8 Pressure switch

- 9 Water softener filter
- 10 Pressure reducer
- 11 Storage cylinder
- 12 Diverter valve
- 13 Pump (fitted as standard for models POWER MAX 65 P and POWER MAX 80 P)

- SE Outdoor sensor
- MI High temperature system flow
- RI High temperature system return
- EAF Domestic cold water inlet
- UAC Domestic hot water outlet

! Domestic hot water and central heating circuits must be completed with expansion vessels of adequate capacity and suitable, correctly-sized safety valves. The discharge of safety valves and appliances must be connected to a suitable collection and disposal system (see Catalogue for compatible accessories).

! The choice of system components and the method of their installation are left up to the heating engineer installing the system. Installers must use their expertise to ensure proper installation and functioning in conformity to all applicable legislation.

! Special supply/refill water must be conditioned using suitable treatment systems.

⊘ It is prohibited to operate the thermal module without water.

Layout 3: circuit with thermal module connected to a heating system via a separator

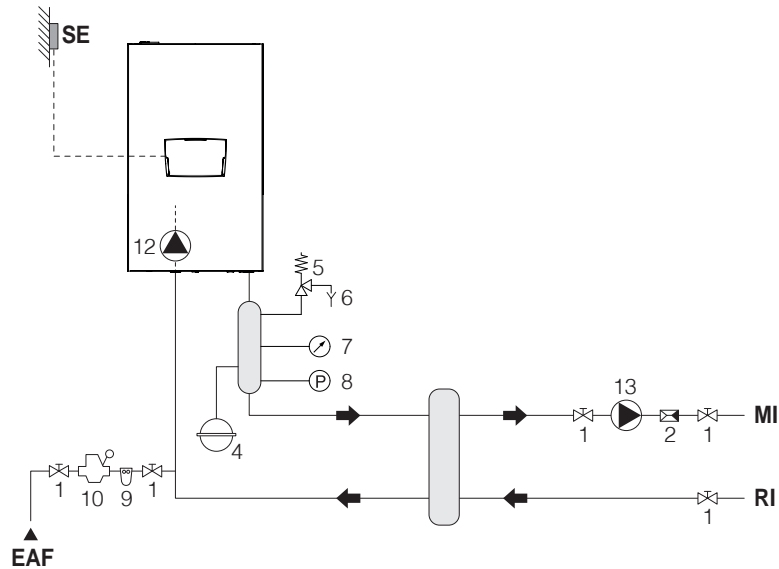

Layout 4: circuit with thermal module linked to DHW tank and heating system via a separator

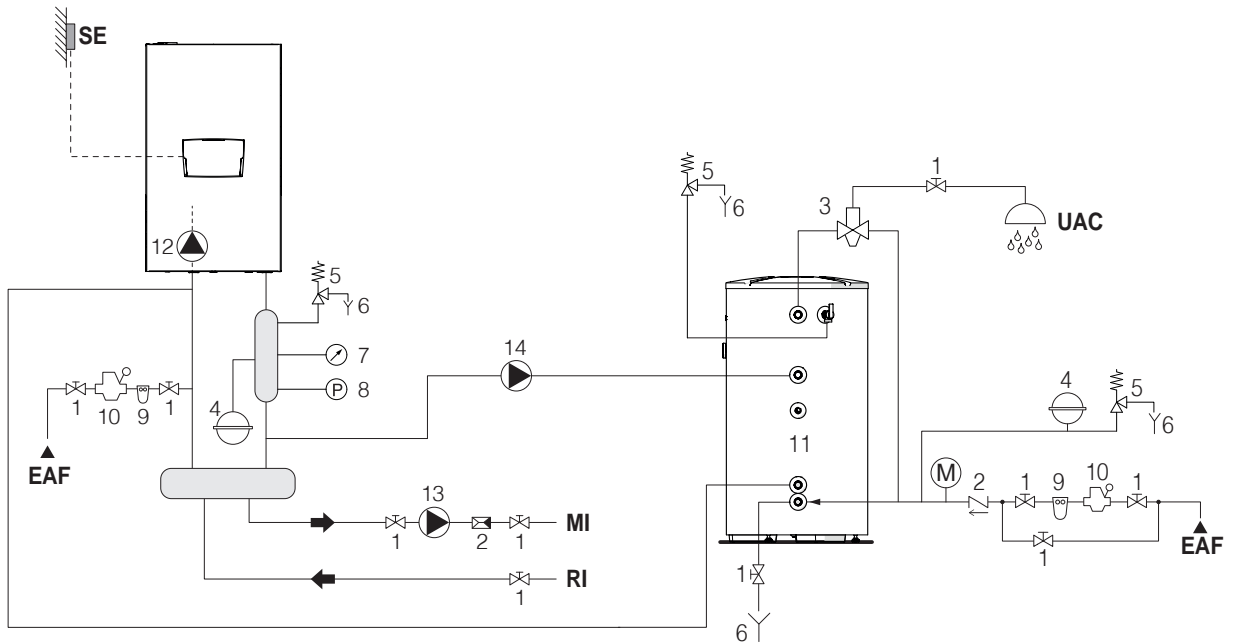

- | | | |
|--------------------------|---|-----------------------------------|
| 1 Isolating valve | 9 Water softener filter | SE Outdoor sensor |
| 2 Non-return valve | 10 Pressure reducer | MI High temperature system flow |
| 3 Anti-scald mixer valve | 11 Storage cylinder | RI High temperature system return |
| 4 Expansion tank | 12 Pump (fitted as standard for models POWER MAX 65 P and POWER MAX 80 P) | EAF Domestic cold water inlet |
| 5 Safety valve | 13 High-temperature system circulator | UAC Domestic hot water outlet |
| 6 Drain | 14 Storage cylinder circulator | |
| 7 Pressure gauge | | |
| 8 Pressure switch | | |

⚠ Domestic hot water and central heating circuits must be completed with expansion vessels of adequate capacity and suitable, correctly-sized safety valves. The discharge of safety valves and appliances must be connected to a suitable collection and disposal system (see Catalogue for compatible accessories).

⚠ The choice of system components and the method of their installation are left up to the heating engineer installing the system. Installers must use their expertise to ensure proper installation and functioning in conformity to all applicable legislation.

⚠ Special supply/refill water must be conditioned using suitable treatment systems.

⊘ It is prohibited to operate the thermal module without water.

Layout 5: circuit with thermal module linked to heating system and DHW. tank via a separator

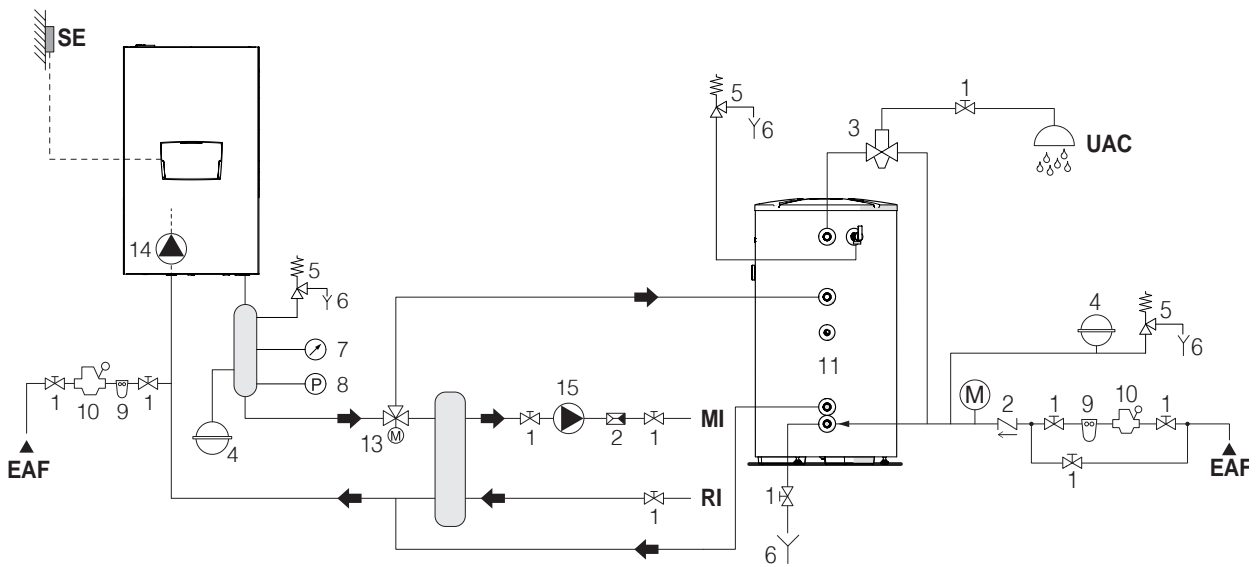

- | | | |
|--------------------------|---|-----------------------------------|
| 1 Isolating valve | 10 Pressure reducer | SE Outdoor sensor |
| 2 Non-return valve | 11 Storage cylinder | MI High temperature system flow |
| 3 Anti-scald mixer valve | 12 Diverter valve | RI High temperature system return |
| 4 Expansion tank | 13 Pump (fitted as standard for models POWER MAX 65 P and POWER MAX 80 P) | EAF Domestic cold water inlet |
| 5 Safety valve | 14 High-temperature system circulator | UAC Domestic hot water outlet |
| 6 Drain | | |
| 7 Pressure gauge | | |
| 8 Pressure switch | | |
| 9 Water softener filter | | |

 Domestic hot water and central heating circuits must be completed with expansion vessels of adequate capacity and suitable, correctly-sized safety valves. The discharge of safety valves and appliances must be connected to a suitable collection and disposal system (see Catalogue for compatible accessories).

 The choice of system components and the method of their installation are left up to the heating engineer installing the system. Installers must use their expertise to ensure proper installation and functioning in conformity to all applicable legislation.

 Special supply/refill water must be conditioned using suitable treatment systems.

 It is prohibited to operate the thermal module without water.

2.9 Gas connections

The gas connection must be made respecting the installation regulations in force, and sized to ensure the correct gas delivery to the burner.

Before making the connection, check that:

- ⚠ The gas type is suitable for the appliance
- ⚠ If the appliance needs to be adapted for use with another gas fuel, contact your local Technical Assistance Centre to have the necessary modifications made. These operations may not be performed by the installer under any circumstances.
- ⚠ The piping is thoroughly clean
- ⚠ The gas meter's flow rate is capable of ensuring the simultaneous use of all the appliances connected to it. The appliance's connection to the gas supply line must be carried out in accordance with the current regulations.
- ⚠ Intake pressure with the appliance in the off position has the following reference values:
 - powered by methane gas: optimal pressure 20 mbar
 - powered by L.P.G.: optimal pressure 37 mbar
- ⊖ Do not use any fuels other than those provided under any circumstances.

While it is normal for the intake pressure to decrease while the appliance is in operation, it is advisable to verify that no excessive pressure fluctuations take place. In order to limit the extent of these types of variations, the diameter of the gas supply line to be used must be assessed based on the length and the pressure drops of the line itself, from the meter to the thermal module.

- ⚠ If fluctuations in the gas distribution pressure are encountered, it is recommended to install an appropriate pressure stabiliser upstream of the appliance's gas intake. For G30 and G31 gas supply, all the necessary precautions must be taken in order to prevent the gas from freezing in the case of extremely low outdoor temperatures.

If the gas distribution network contains solid particles, install a filter on the fuel supply line. When selecting it, consider that pressure drops due to the filter should be as low as possible.

- ⚠ On completion of the installation, check that all joints are sealed.

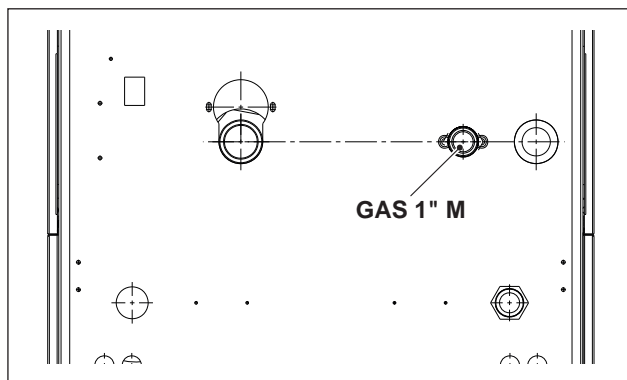

2.10 Discharge of combustion products

The appliance is supplied as standard in B-type configuration (B23-B23P-B53P), i.e. pre-fitted to suction air directly into the installation room and may be converted into a C-type appliance with the use of specific accessories. In this configuration, the appliance will suction the air directly from outdoors, with the possibility of coaxial or dual piping. For flue gas extraction and the intake of combustion air, it is essential to use only specific pipes for condensing boilers and ensure that they are correctly connected, as shown in the instructions supplied with the flue gas accessories.

- ⚠ Do not connect this appliance's flue gas extraction pipes with those of other appliances, unless this is specifically authorised by the manufacturer. Non-compliance with this precaution may cause a build-up of carbon monoxide in the room where the appliance is installed. This could jeopardise people's health and safety.
- ⚠ For further information on flue gas extraction pipes for thermal modules connected in a cascaded system, see Catalogue and the instructions provided for the relevant accessories.
- ⚠ Ensure that combustion air (suction line air) is not contaminated by:
 - waxes/chlorinated detergents
 - chemical products based on swimming pool chlorine
 - calcium chloride
 - sodium chloride use to soften tap water
 - refrigerant leaks
 - paint or varnish removers
 - chloridric acid/muriatic acid
 - cements and glues
 - anti-static softeners used in dryers
 - chloride used for domestic or industrial applications as detergent, whitener or solvent
 - adhesives used to glue construction and other similar products.
- ⚠ To prevent contamination of the thermal module, do not install suction line air intakes and gas flue extraction pipes near:
 - dry-cleaners/laundry rooms and factories
 - swimming pools
 - metal processing plants
 - beauty parlours
 - fridge repair shops
 - photo-processing facilities
 - body-shops
 - plastics manufacturing plants
 - furniture workshops and manufacturing plants.

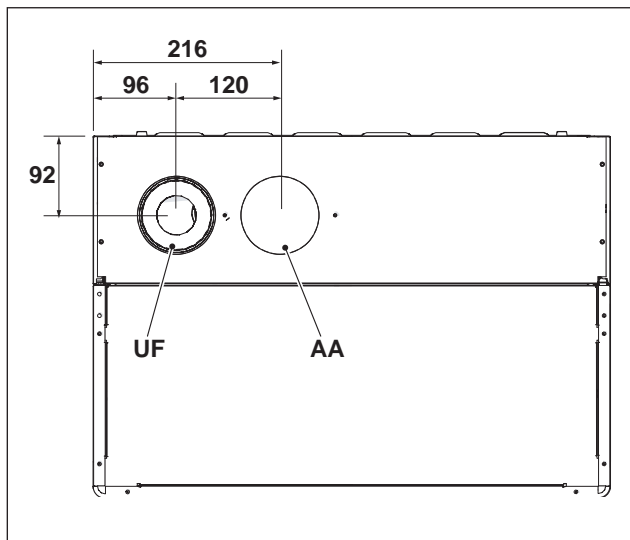

The AA outlet is supplied capped in B23 configuration.

DESCRIPTION	POWER MAX		
	65 P	80 P	
FO (flue gas outlet)	DN80	DN80	∅
AS (air suction)	DN80	DN80	∅

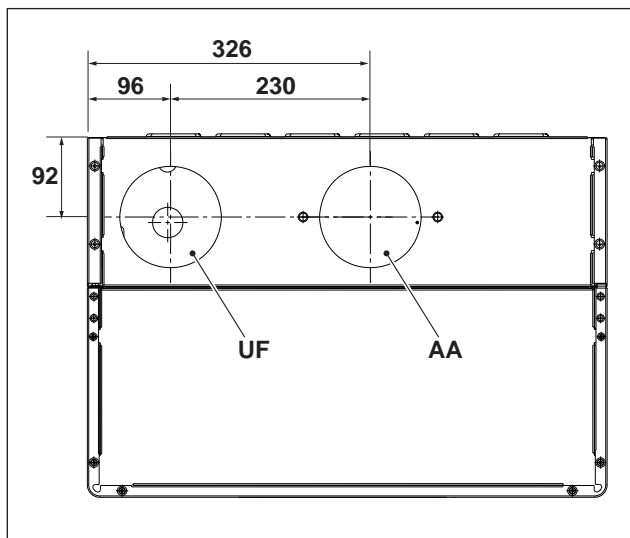

The AA outlet is supplied capped in B23 configuration.

DESCRIPTION	POWER MAX				
	100	110	130	150	
FO (flue gas outlet)	DN110	DN110	DN110	DN110	∅
AS (air suction)	DN110	DN110	DN110	DN110	∅

⚠ For B-type installation, combustion air is taken from the environment and goes through the openings (shutters) on the rear panel of the device that must be located in a suitable and ventilated technical room.

⚠ Read the requirements, instructions and prohibitions detailed below carefully, since non-compliance with them may be result in a safety hazard or the appliance's malfunction.

⚠ Condensation appliances described in this handbook must be installed with flue gas pipes compliant with applicable legislation and expressly manufactured for this specific use.

⚠ Check that pipes and joints are not damaged.

⚠ Joint seals must be executed with materials that withstand the condensate's acidity and the temperatures of the appliance's flue gases.

⚠ When installing flue pipes, always bear in mind the direction of the flue gases and of possible condensate flows.

⚠ Inadequate or incorrectly sized flue gas pipes may increase combustion noise, create condensate extraction issues and negatively impact on combustion parameters.

⚠ Check that pipes are suitably far (min. 500 mm) from flammable or heat-sensitive construction elements.

⚠ Make sure that condensation is not built up along the duct. For this purpose, provide a sloping duct of at least 3 degrees towards the appliance in case there is an a horizontal section. If the horizontal or vertical section is longer than 4 meters, a condensate siphon drainage must be provided at the base of the pipe. The useful height of the siphon must be at least equal to the value "H" (see figure below). The siphon discharge must then be connected to the sewerage system (see paragraph "Preparation for the condensate drain" on page 25).

⊘ It is prohibited to block or section the flue gas extraction pipe or the combustion air suction pipe, if any.

⊘ It is prohibited to use pipes that not designed for this application, because the condensate's action would damage them quickly.

Below are tables showing the maximum equivalent lengths for the different available models.

B TYPE INSTALLATION

Exhaust Ø 80 mm

Model	Maximum length Ø 80 mm	Pressure drop	
		45° bend	90° bend
POWER MAX 65 P	30 m	1,5 m	5 m
POWER MAX 80 P	30 m	1,5 m	3 m

Exhaust Ø 110 mm

Model	Maximum length Ø 110 mm	Pressure drop	
		45° bend	90° bend
POWER MAX 100	30 m	1,5 m	3 m
POWER MAX 110	30 m	1,5 m	3 m
POWER MAX 130	30 m	1,5 m	3 m
POWER MAX 150	30 m	2 m	4 m

C TYPE INSTALLATION

Double pipes Ø 80-125 mm

Model	Maximum length Ø 80-125 mm	Pressure drop	
		45° bend	90° bend
POWER MAX 65 P	15 m	2 m	6 m
POWER MAX 80 P	15 m	2 m	6 m

Double pipes Ø 110-160 mm

Model	Maximum length Ø 110-160 mm	Pressure drop	
		45° bend	90° bend
POWER MAX 100	15 m	2 m	6 m
POWER MAX 110	15 m	2 m	6 m
POWER MAX 130	15 m	2 m	6 m
POWER MAX 150	15 m	4 m	8 m

Double pipes Ø 60-100 mm

Model	Maximum length Ø 60-100 mm	Pressure drop	
		45° bend	90° bend
POWER MAX 65 P	10 m	2 m	4 m
POWER MAX 80 P	10 m	3 m	6 m

Separate pipes Ø 80 mm + Ø 80 mm

Model	Maximum length Ø 80 + Ø 80 mm	Pressure drop	
		45° bend	90° bend
POWER MAX 65 P	15 m + 15 m	1,5 m	3 m
POWER MAX 80 P	15 m + 15 m	1,5 m	3 m

Separate pipes Ø 110 mm + Ø 110 mm

Model	Maximum length Ø 110 + Ø 110 mm	Pressure drop	
		45° bend	90° bend
POWER MAX 100	15 m + 15 m	1,5 m	3 m
POWER MAX 110	15 m + 15 m	1,5 m	3 m
POWER MAX 130	15 m + 15 m	1,5 m	3 m
POWER MAX 150	15 m + 15 m	2 m	4 m

The table with available residual discharge heads is shown below.

Description	Discharge head	
	Max	Min
POWER MAX 65 P	510	35
POWER MAX 80 P	630	35
POWER MAX 100	560	32
POWER MAX 110	610	32
POWER MAX 130	500	30
POWER MAX 150	353	28

(*) with DN80 clapet accessory (Compulsory for cascade installations)

The residual discharge head values are shown in Pascal.

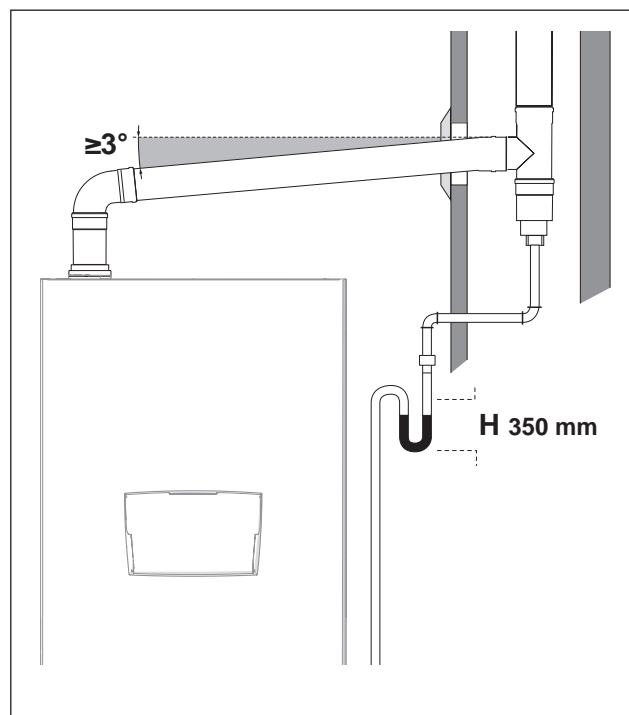

To change direction, use a T section with an inspection cap to permit easy access for cleaning inside the pipe. After cleaning, always make sure that inspection caps are replaced tightly and that their seals are undamaged and efficient.

2.10.1 Preparation for the condensate drain

The evacuation of the condensate produced by the appliance **POWER MAX** during its normal operation must be carried out through a siphoned condensate collector, placed under the thermal module itself. This collector is available as an accessory for models POWER MAX 65 P ÷ POWER MAX 150.

The condensate coming out of the drainer must be collected for dripping into a taped vessel connected to the sewer system, if necessary by interposing a neutralizer (for more information see paragraph "Neutralising the condensate"), according to the following procedure:

- Fit a drip tray near the condensate discharge outlet, adding a condensate neutraliser if necessary
- Connect the drip collection receptacle to the local drain or sewer system using a siphon.

The drip tray can be created by fitting a cup or simply a polypropylene bend, suitable for collecting the condensate that comes out of the appliance and any liquid leaking from the safety valve.

The maximum distance between the condensate drainage of the appliance and the socket (or socket pipe) must not be less than 10 mm.

The connection to the local drain or sewer system must be executed using a siphon in order to prevent unpleasant odours from being released back into the room from the sewer.

We advise using plastic (PP) piping for building the condensate drainage.

⊘ Never use copper pipes under any circumstances, as the condensate itself will cause them to rapidly deteriorate.

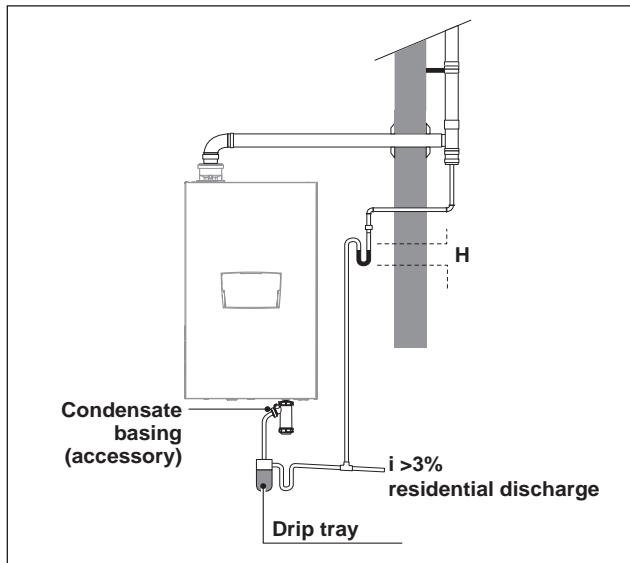

⚠ Execute the condensate drain outlet so as to prevent combustion gases leaking into the environment or the drain or sewage system by sizing the siphon (height H) as described in Paragraph "Discharge of combustion products".

⚠ Always maintain a slope angle "s" of over 3° and ensure that the diameter of any condensate drain pipe is greater than that of the connection fitted at the drain outlet.

⚠ Connect the condensate drain hose to a domestic water drain in accordance with national and local legislation and standards.

⚠ Fill the siphon with water before activating on the thermal module in order not to release any combustion products into the environment when the thermal module is first switched on.

⚠ The condensate drain must be suitably siphoned. Fill the siphon with drain in order to prevent the release of combustion products when the appliance is first switched on.

⚠ It is recommended that condensate from the thermal module and from the flue should be channelled to the same drain pipe.

⚠ The connection pipes used must be as short and as straight as possible. Any curves or sharp bends can lead to hoses becoming clogged and, therefore, can prevent proper condensate discharge.

⚠ Size the condensate drain outlet so as to ensure the proper drainage of waste liquids without leaks.

⚠ The condensate drain must be connected to the drain and sewage network in such a way so that the condensate may not freeze under any circumstances.

2.11 Neutralising the condensate

The UNI 11528 standard requires the neutralisation of condensate for systems with a total power exceeding 200 kW. Neutralisation for systems with a total power ranging between 57 and 200 kW may or may not be required. It depends on the number of flats (for residential applications) or the number of occupants (for non-residential applications) served by the system.

2.11.1 Water quality requirements







It is **ABSOLUTELY NECESSARY** to treat the water system in order for the heat generator to work properly and to guarantee its service life, as well as that of all its components. This not only applies to jobs carried out on existing installations but also on new installations.

Sludge, lime-scale and pollutants contained in the water can cause permanent damage to the heat generator, also within a short time and notwithstanding the quality standards of the materials used.

Contact the Technical Assistance Centre for any further information on type and use of additives.

The heat transfer fluid (water) for the central heating circuit must conform to the quality parameters given in the following table:

Parameters	Value	Unit
General characteristic	Colourless, without sediment	
PH value	Min. 6.5; Max. 8	PH
Dissolved oxygen	< 0,05	mg/l
Total iron (Fe)	< 0,3	mg/l
Total copper (Cu)	< 0,1	mg/l
Na2SO3	< 10	mg/l
N2H4	< 3	mg/l
PO4	< 15	mg/l
CaCO3	Min. 50 ; Max. 150	ppm
Trisodium phosphate	None	ppm
Chlorine	< 100	ppm
Electrical conductivity	< 200	µS/cm
Pressure	Min. 0.6; Max. 6	bar
Glycol	Max. 40% (only propylene glycol)	%

-  All data in the table refer to water contained in the system after 8 weeks' operation.
-  Do not use excessively softened water. Excessive water softening (total hardness < 5° f) results in corrosion due to contact with metal elements (pipes or thermal module components)
-  Immediately repair any leaks or drips that could result in air entering the system
-  Excessive pressure fluctuations can cause stress and fatigue to the heat exchanger. Keep the operating pressure constant.
-  Water used to fill a system for the first time and water used to top it up must always be filtered (using synthetic or metal mesh filters with a filtration rating of no less than 50 microns) to prevent sludge from forming and triggering deposit corrosion.
-  If oxygen enters a circuit continuously or even intermittently (e.g. in under-floor heating systems whose pipes are not protected by impermeable synthetic sheaths, in circuits with open expansion vessels, or in circuits that require frequent top-ups) always separate the boiler's water circuit from the central heating circuit.
-  It is prohibited to top up the heating system constantly or frequently, since this can damage the thermal module's heat exchanger. The use of automatic topping up systems should be avoided for this reason.

To sum up, in order to eliminate contact between air and water (and to prevent the latter from becoming oxidized), it is necessary:

- that the expansion system be a closed vessel, correctly sized and with the correct pre-loading pressure (to be regularly checked);
 - that the system be always at a pressure higher than the atmospheric one at any point (including the pump suction side) and under any operating conditions (all seals and hydraulic couplings in a system are designed to withstand pressure towards the outside, but not underpressure);
 - the installation be not made with gas-permeable materials (e.g. plastic pipes without oxygen barrier for underfloor heating systems)
-  Damages suffered by the thermal module, caused by encrustations and corrosion, are not covered by warranty. In addition, the non compliance of the water requirements listed in this chapter will void the appliance warranty itself.

2.12 System filling and emptying

The thermal module **POWER MAX** must be provided with a charging system to be connected to the appliance's return line.

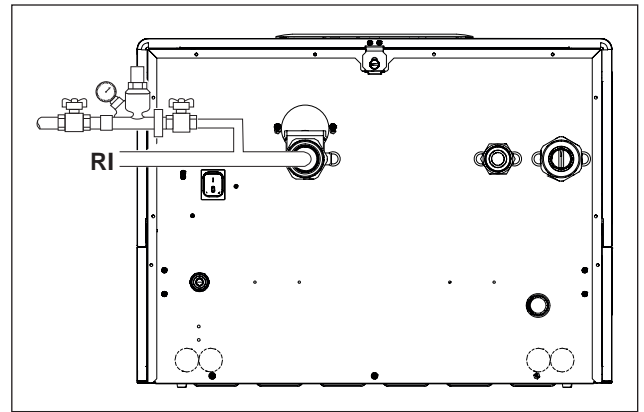

Before filling or emptying the system, switch the system's master switch to the OFF position and the thermal module's master switch to (0).

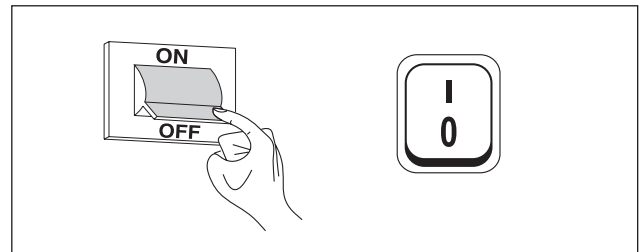

2.12.1 Filling

- Make sure that drain cocks (1) are closed before you start loading the system

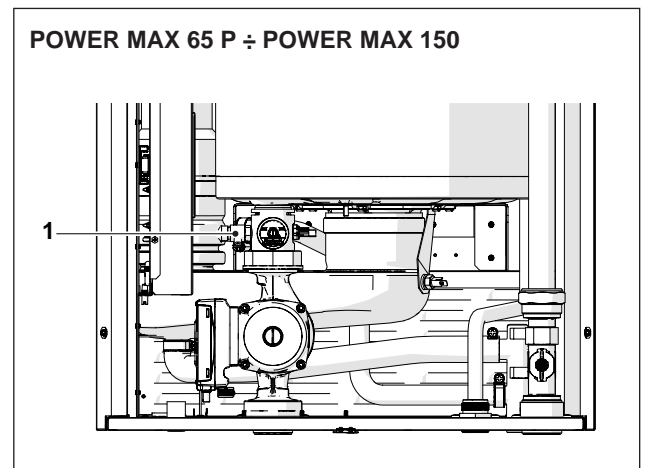

- Unscrew the vent valve's release cap
- Open the shut-off cocks in order to slowly fill the system
- Use the pressure gauge to check that the pressure is rising and the water is exiting through the vent valves
- Close the shut-off cocks after the pressure reaches 1.5 bar
- Start the system pumps and the thermal module's pump as shown in Paragraph "Commissioning and maintenance"
- During this stage, check that the air is correctly eliminated
- Restore the pressure if necessary
- Switch the pumps off and on again
- Repeat the last three steps until the pressure is stabilised

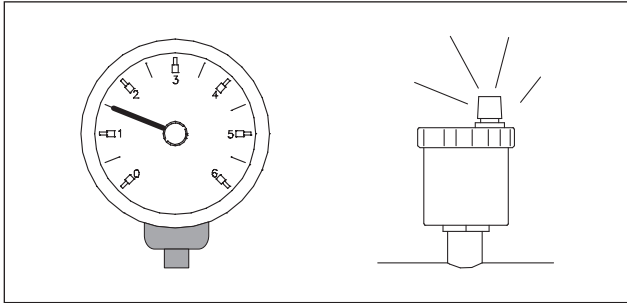

- ⚠ The system must be filled up slowly the first time; once it is filled and the air expelled it should never need to be topped up again.
- ⚠ Systems should also be operated at maximum working temperature the first time they are started up, in order to facilitate de-aeration. (Gas is not released from the water at low temperatures).
- ⚠ An automatic spurge can be performed during the first ignition. The parameter that set the cycle is Par. 2139. See parameter table for more information.

2.12.2 Emptying

Before starting to empty the appliance and the storage cylinder:

- Switch the system's master switch to the OFF position and the thermal module's master switch to **(0)**.

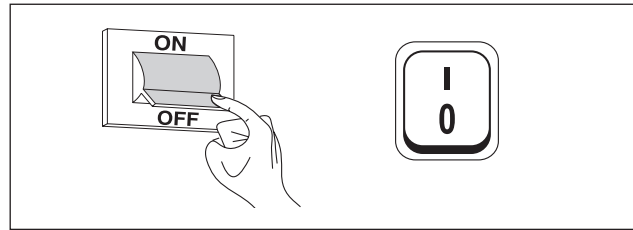

- Close the water supply shut-off cocks;
- In order to empty the appliance, fit a rubber hose (2) (inner diameter int. $\varnothing = 12$ mm) to the thermal module's discharge valve (1).

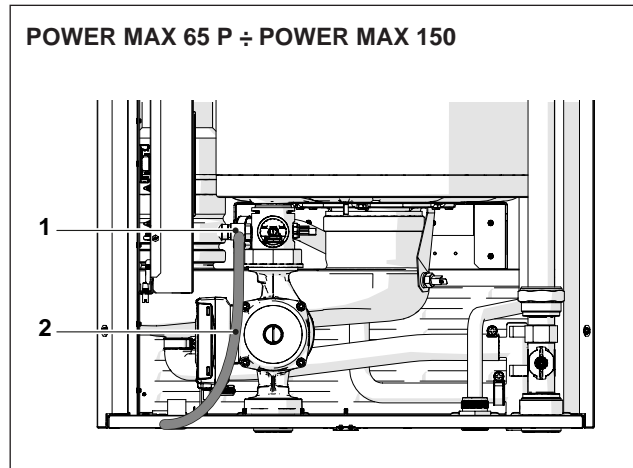

2.13 Wiring diagram

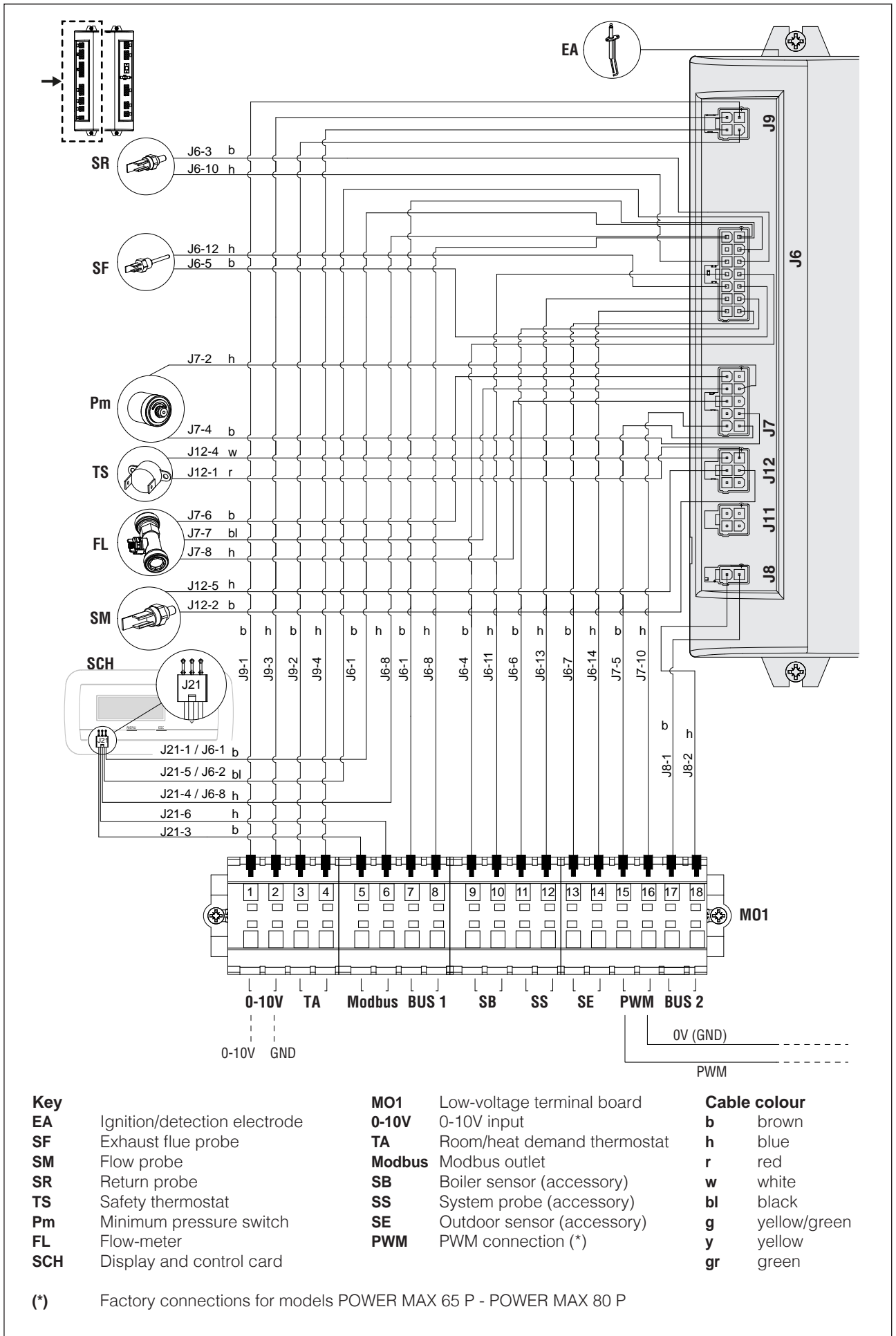

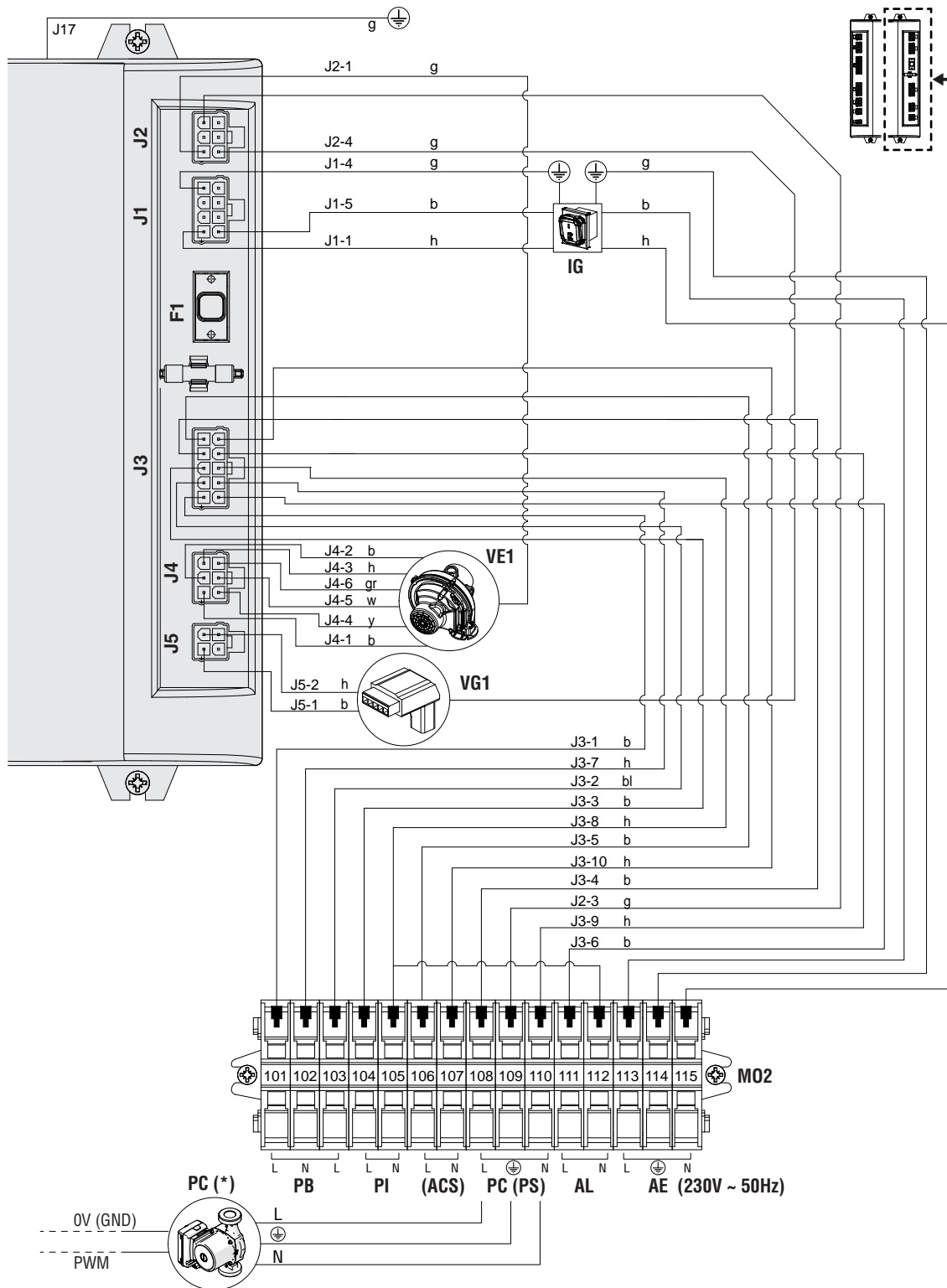

Key		PI	Central heating system pump	Cable colour	g	yellow / green
IG	Main switch	(ACS)	DHW circulator (**)	b	brown	green
VG1	Gas valve	PC	Thermal module circulator (*)	h	blue	yellow
VE1	Variable speed fan	PS	System circulator (**)	r	red	green
MO2	High-voltage terminal board	AL	Alarm output (***)	w	white	
PB	Storage cylinder circulator/ 3-way valve/2-way valve (**)	AE	Power supply	bl	black	

(*) For models POWER MAX 65 P - POWER MAX 80 P circulator fitted as standard; for other models, the circulator is provided as an accessory with connections to be executed by the installer.

(**) Valid configuration for thermal modules without heat pump c having their own two-way valve, connected in cascade and equipped with primary system circulator. For more information, see cascade installation manual.

(***) Connect a resistive load between 10VA and 50VA.

2.14 Electrical connections

The thermal module **POWER MAX** is manufactured fully wired and only needs to be connected to the mains, the room/heat demand thermostat and any other system components.

- ⚠ The following is mandatory:
 - The use of an omnipolar magnetothermic switch, line disconnecting switch in compliance with CEI-EN standards (contact opening of at least 3 mm)
 - Respect the connection L (line) - N (neutral). Keep the earth conductor 2 cm longer than the power supply conductors
 - Use cables with a section greater than or equal to 1.5 mm², complete with cable terminal caps
 - Refer to the wiring diagrams in this manual for all electric operations.
- ⚠ The use of adaptors, multiple sockets and extensions to power the appliance is not allowed
- ⚠ to connect external electric components, it is necessary to use auxiliary relays and/or contactors to be fitted in a dedicated external electrical panel
- ⚠ Any work on the electrical system must be carried out only by qualified personnel in compliance with all legal provision and safety regulations in particular
- ⚠ Secure the cables into the dedicated cable ties in order to always guarantee their correct positioning within the appliance.
- ⚠ Electrical supply cables and control cables (room/heat demand thermostat, external temperature probes, etc.) must be strictly separate the one from the other and fitting inside independent ribbed PVC sheaths up to the electrical panel.
- ⚠ The connection to the electrical power supply must be performed using type 1 sheathed cables (3 x 1,5) N1VVK or equivalent, while simple N07VK type or equivalent conductors can be used for the thermoregulation and low voltage circuits.
- ⚠ If the electrical power provided by the electrical company is of "**PHASE-PHASE**" connection type, preventively contact the nearest Technical Assistance Centre.
- ⚠ Never shut the appliance off during normal operation (with the burner on) by shutting off the electrical power supply using the On-Off key or an external switch. This could cause the primary heat exchanger to over-heat.

- ⚠ To switch it off (during the heating stage) use a room/heat demand thermostat. The On-Off key can only be actioned whilst the appliance is in stand-by or emergency mode.
- ⚠ Before connecting any external electrical components to the appliance (regulators, electric valves, climate control probes, etc.), check to make sure that their electrical characteristics are compatible with the available inputs and outputs (voltage, absorption, acceleration current).
- ⚠ Temperature probes must be NTC like. For resistance value, refer to table pag 12.
- ⚠ Always check the proper operation of the "grounding conductor" for the electrical system to which the appliance will be connected.
- ⚠ **Beretta** shall bear no responsibility for any personal injuries or property damage caused by non-compliance with wiring diagrams or the electrical system's incorrect/lacking connection to the grounding system, or by non-compliance with applicable CEI Standards.
- ⊖ It is strictly forbidden to use pipes of any kind to ground the appliance.
- ⊖ It is prohibited to lay power supply and room/heat demand thermostat cables near hot surfaces (delivery pipes). If they may come into contact with parts that have a temperature of over 50°C, use a suitable type of cable.
- ⊖ It is prohibited to touch electric appliances with damp/wet body parts or when your feet are wet.
- ⊖ It is prohibited to leave the appliance exposed to weather elements (rain, sun, wind, etc.).
- ⊖ It is prohibited to pull, detach, or twist any electric cables coming from the thermal module even when the latter is disconnected from the mains power supply.

Proceed as follows to access the control panel terminals:

- Remove the locking screws and the panel's front side
- Pull and slide the electrical panel's box towards the outside (1)

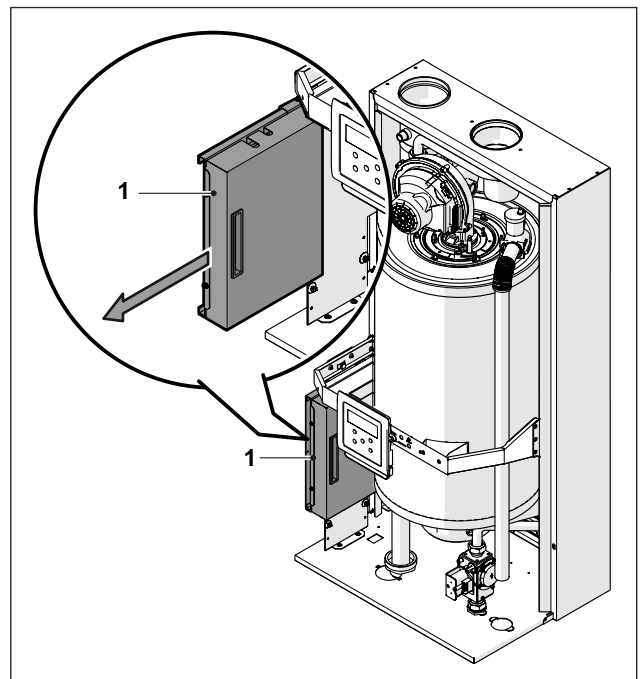

Loosen the fixing screws (2) and remove the protection (3)

For connection, see the following figure:

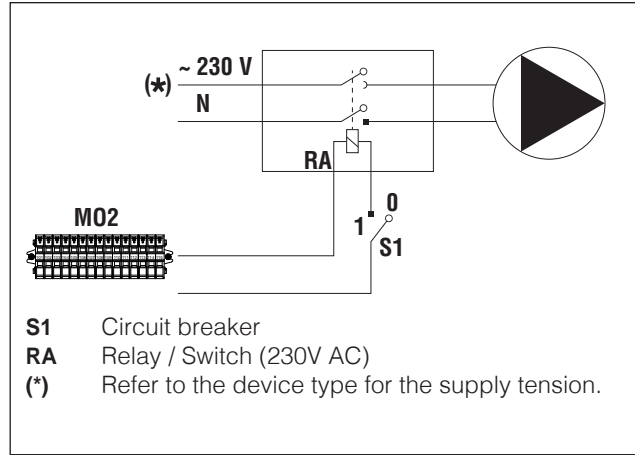
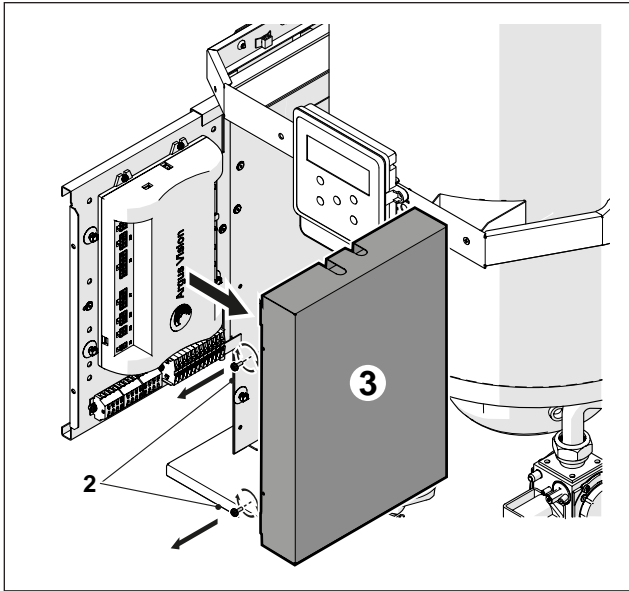

- Identify the low-tension terminal board (MO1) and the high-tension terminal board (MO2)

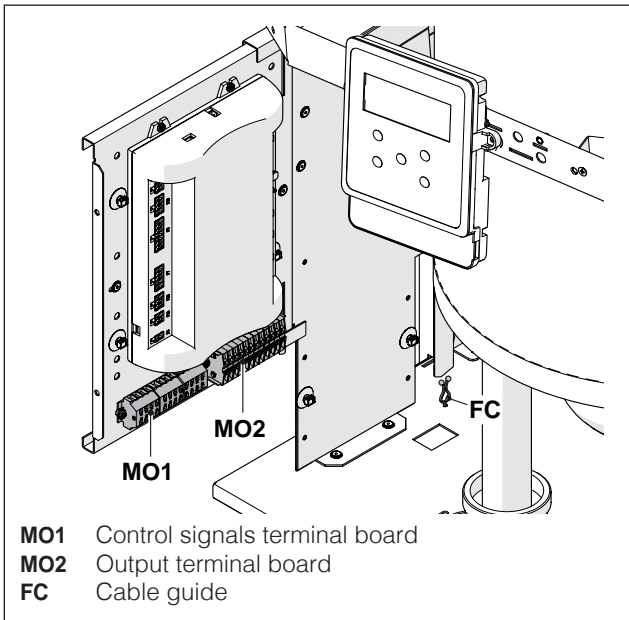

- Execute electrical wiring in compliance with the diagrams shown below

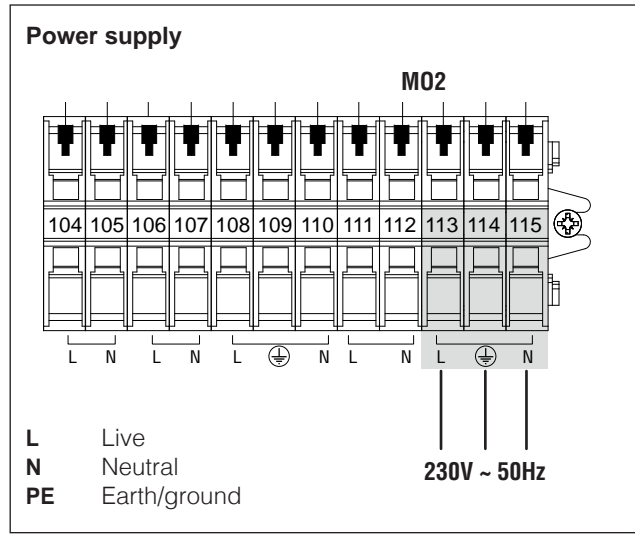

! For the connection of the devices connected to the jig (pumps, circulators and diverting / mixing valves) use interposed relays unless the maximum absorption of all components connected to the board (including the module circulator) is less than or equal to 1.5 A. Relays sizing lays on the installer depending on the type of connected device.

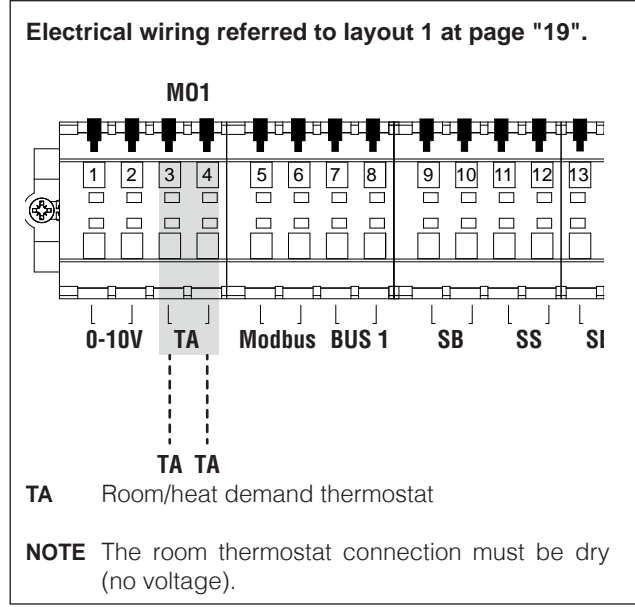

Electrical wiring referred to layout 2 at page "19".

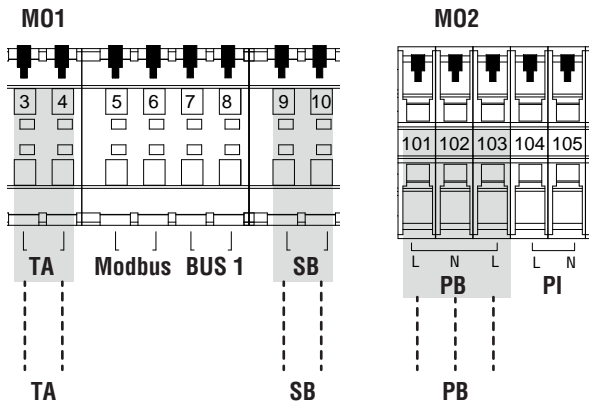

- TA** Room/heat demand thermostat
SB Connect to the storage cylinder probe (Mod. San. 1) or to the storage cylinder thermostat (Mod. San. 2)
PB Connect to the deviating valve (13). Contacts 101-102 control the deviation on heating, contacts 102-103 control the deviation on domestic hot water

NOTE The room thermostat connection must be dry (no voltage).

Electrical wiring referred to layout 4 at page "20".

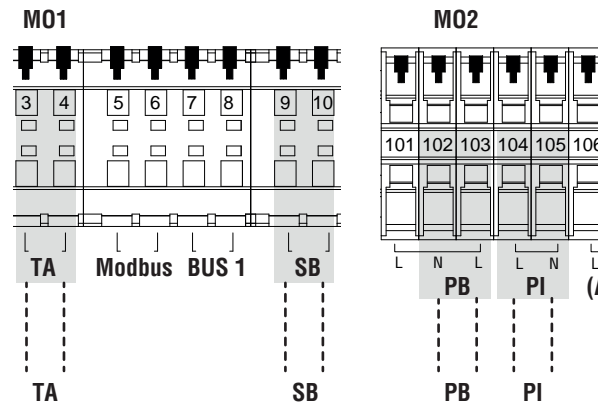

- TA** Room/heat demand thermostat
SB Connect to the storage cylinder probe (Mod. San. 1) or to the storage cylinder thermostat (Mod. San. 2)
PB Connect to the deviating valve (13)
PI Connect to the high temperature system pump

NOTE The room thermostat connection must be dry (no voltage).

Electrical wiring referred to layout 3 at page "20".

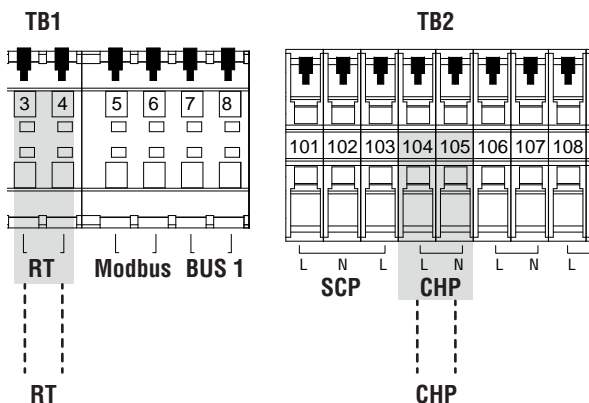

- TA** Room/heat demand thermostat
PI Connect to the high temperature system pump

NOTE The room thermostat connection must be dry (no voltage).

Electrical wiring referred to layout 5 at page "21".

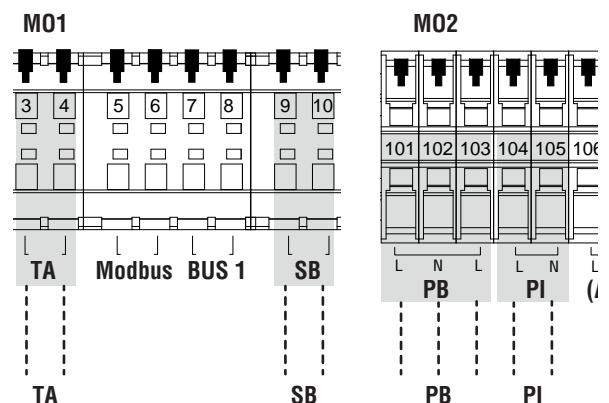

- TA** Room/heat demand thermostat
SB Connect to the storage cylinder probe (Mod. San. 1) or to the storage cylinder thermostat (Mod. San. 2)
PB Connect to the deviating valve (13). Contacts 101-102 control the deviation on heating, contacts 102-103 control the deviation on domestic hot water
PI Connect to the high temperature system pump

NOTE The room thermostat connection must be dry (no voltage).

⚠ Some electric connections of the power jig have a double function. With special reference to the principle schemes 2 and 5 where no tank pump is foreseen, the two-way valve of each module must be connected to the abovementioned connections 101-102-103.

2.15 Menu navigation

2.15.1 USER navigation MENU

Whilst turning on or when any key is pushed for more than 4 minutes, the display is placed on the "basic display" and it provides some general information on the thermal module.

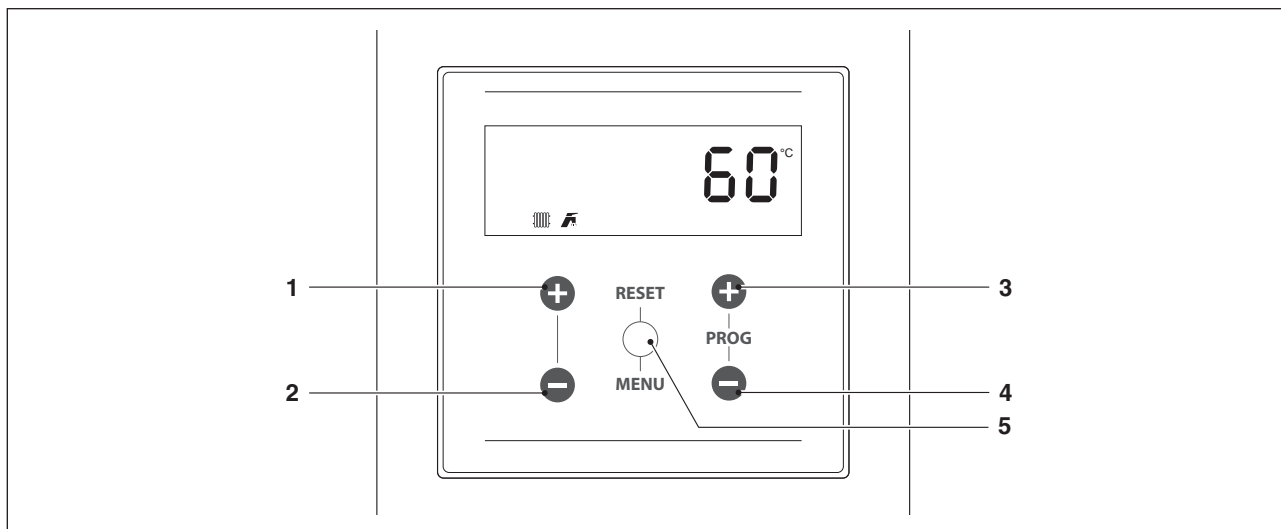

In this mode, keys have the following functions:

Nr.	Button	Function
1	"+"	Raise the heat set point (when available)
2	"-"	Decrease the heat set point (when available)
3	"PROG +"	Raise the DHW set point (when available)
4	"PROG -"	Decrease the DHW set point (when available)
5	"MENU/RESET"	Enters into "MENU" mode If pressed for more than 2 seconds, it resets a non volatile failure

MENU selection

Enters into "MENU" mode when "MENU/RESET" key is pushed. The figures of the small display indicate "0000" which is the first accessible menu.

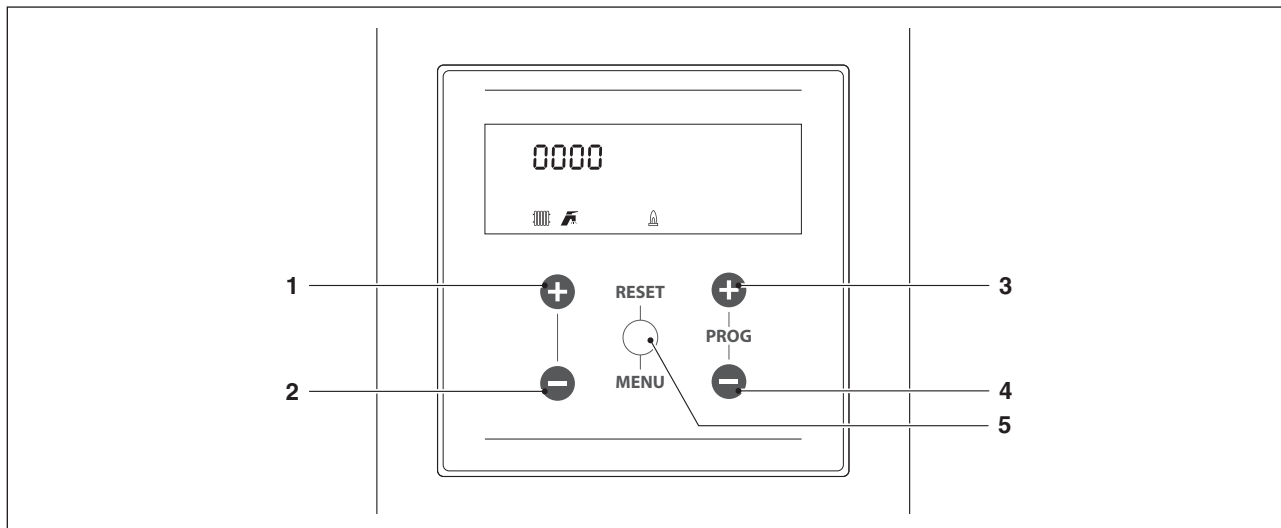

In this mode, keys have the following functions:

Nr.	Button	Function
1	"+"	Exits from the menu and cancels a parameter change
2	"-"	Exits from the menu and cancels a parameter change
3	"PROG +"	Selects the following menu or increases a certain parameter value
4	"PROG -"	Selects the previous menu or decreases a certain parameter value
5	"MENU/RESET"	Enters into the selected menu/parameter or confirms the parameter change

USER menu					
Par. No.	Parameter name	Description	Range	Factory setting	UM
2003	CH set-point	Defines the desired delivery temperature in heating mode (Par. 2001) = 0.	Par. 2023... Par. 2024	70	°C
2048	DHW tank set-point	Establishes the DHW storage tank set-point.	40...71	50	°C
0200		Activates the test mode: off = test mode off fan = the fan is running at the max speed with the burner off lo = module is brought to min (when on) ign = module is brought to the ignition speed (when on) Hi = the module is brought to the max (when on) reg = the module is brought to the max power but it is set according to the temperature (when on)	off/fan/lo/ ign/hi/reg	Off	
0901		It defines the temperature units	C/F	C	
0902		It defines the pressure units	bar/psi	bar	
1001		CH flow temperature	Only display		°C
1002		Domestic hot water temperature	Only display		°C
1003		DHW temperature	Only display		°C
1004		Outside temperature	Only display		°C
1005		2° Delivery temperature	Only display		°C
1006		Flue gas temperature	Only display		°C
1007		Flue gas temperature	Only display		°C
1008		Ionisation current	Only display		µA
1009		Status of the primary pump (on/off)	Only display		
1010		Status of the heating system pump (on/off)	Only display		
1011		Status of the DHW pump (on/off)	Only display		
1012		Calculated heating set point (on climatic mode)	Only display		°C
1013		Status of the room thermostat/heat demand (opened/closed)	Only display		
1014		2° Flue gas temperature	Only display		°C
1015		Secondary probe temperature (if on)	Only display		°C
1030		State	Only display		
1031		Error code	Only display		
1033		CH pressure	Only display		
1040		Actual fan speed	Only display		RPM
1041		Ignition fan speed	Only display		RPM
1042		Fan speed at the minimum	Only display		RPM
1043		Fan speed at the maximum	Only display		RPM
1051		Code of the last permanent error	Only display		
1052		Code of the last temporary error	Only display		
1053		Number of flame ignition failures	Only display		
1054		Number of successful ignitions	Only display		
1055		Number of failed ignitions	Only display		
1056		Total heating hours	Only display		Hr x 10
1057		Total Sanitary hours	Only display		Hr x 10
1058		Total working days	Only display		Days
1059		Time delay from the last Permanent error The measuring unit is defined by the number preceding the value. 1: = minutes 2: = hours 3: = days 4: = weeks	Only display		
1060		Time delay from the last Temporary error The measuring unit is defined by the number preceding the value. 1: = minutes 2: = hours 3: = days 4: = weeks	Only display		
1061		Instantaneous turbine speed	Only display		RPM
1062		Water flow of the present module	Only display		from/ min
1063		Signal voltage 0-10 on inlet	Only display		Volt
1090		Days of service	Only display		Days
1098		Scheme type	Only display		
1099		Software version identification code	Only display		
Code		Enter menu password INSTALLER / MANUFACTURER			

2.15.2 Navigation Menu INSTALLER / MANUFACTURER

It is necessary to enter the password to access the INSTALLER / MANUFACTURER parameters

- Press "MENU/RESET" and select "Code" by using the "PROG +" and "PROG -".



- Press "MENU/RESET" to confirm
- "0---" is displayed on the big numeric display and the first digit is blinking



- Press "PROG +" and "PROG -" to increase or decrease the value of the first blinking digit
- When the desired value is reached on the single figure, press "MENU/RESET" to confirm the inserted value thus the second digit starts blinking
- Repeat the same procedure for all four figures and enter the password

After entering the INSTALLER or MANUFACTURER password, the related menu and parameters will be displayed.

The system provides for three types of access:

USER: password 0000

INSTALLER: password 0300

MANUFACTURER



After it is entered, the password is active during display and/or parametrisation. If the display is inactive for a few minutes, it needs to be re-entered.

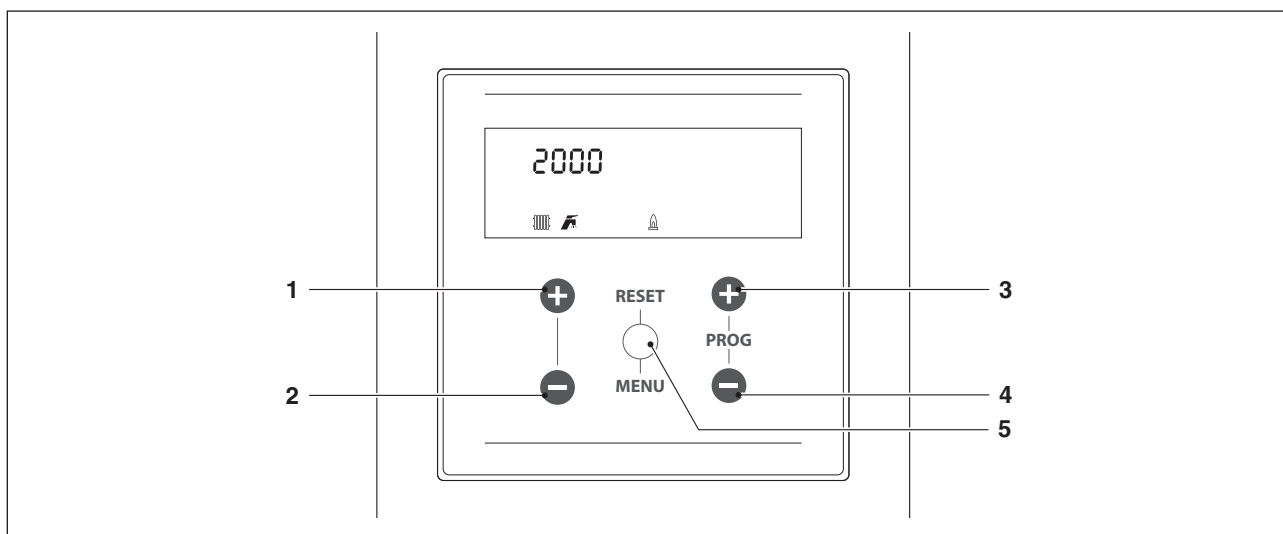

35

In this mode, keys have the following functions:

Nr.	Button	Function
1	"+"	Exits from the menu and cancels a parameter change
2	"-"	Exits from the menu and cancels a parameter change
3	"PROG +"	Selects the following menu or increases a certain parameter value
4	"PROG -"	Selects the previous menu or decreases a certain parameter value
5	"MENU/RESET"	Enters into the selected menu/parameter or confirms the parameter change

MENU INSTALLER / MANUFACTURER					
Par. No.	Parameter name	Description	Range	Default setting	UM
2001	CH mode	Defines the thermal module's various heating operation modes.	0...5	0	
2003	CH set-point	Defines the desired delivery temperature in heating mode (Par. 2001) = 0.	Par. 2023... Par. 2024	70	°C
2005	Boiler Pump Overrun	Sets the overrun time in seconds of the boiler's circulator during stand-alone operation; cascaded operation determines the module's overrun after switch-off due to temperature control.	0...900	60	Sec.
2007	CH Hysteresis Up	Sets the value in degrees beyond the set-point at which the burner switches off for thermoregulation.	0...20	5	°C
2009	Anti-cycle Period	Sets the stand-by time before the appliance is switched on again after it switches off due to thermoregulation, independently from the delivery temperature dropping below the value indicated in Par. 2010. Parameter valid only in stand-alone mode.	10...900	120	Sec.
2010	Anti-cycle Temp. Diff.	Sets the value in degrees below which the burner switches on again notwithstanding from the time spent at Par. 2009.	0...20	16	°C
2014	Max. Power CH	Sets the heating's % max. power.	50...100	100	%
2015	Min. Power CH	Sets the heating's % min. power.	1...30	1	%
2019	Design Supply Temp.	Defines the max. set-point at the minimum outdoor temperature for climatic regulation.	30...90	80	°C
2020	Design Outdoor Temp.	Defines the minimum outdoor temperature to which the maximum set-point can be associated for climatic regulation.	-25...25	0	°C
2021	Baseline Supply Temp.	Defines the minimum set-point at the maximum outdoor temperature for climatic regulation.	30...90	40	°C
2022	Baseline Outdoor Temp.	Defines the maximum minimum outdoor temperature to which the minimum set-point can be associated for climatic regulation.	0...30	20	°C
2023	Design Supply Min. Limit	Limits the minimum value that can be assigned to the set-point in heating mode (does not apply to heating mode 4).	4...82	30	°C
2024	Design Supply Max. Limit	Limits the maximum value that can be assigned to the set-point in heating mode (does not apply to heating mode 4).	27...90	80	°C
2025	Warm Weather Shutdn	Defines the temperature at which climatic regulation is switched off.	0...35	22	°C
2026	Boost Temp Increment	Establishes the set-point temperature increase ΔT , if the heat demand in heating mode is not satisfied after the time interval specified in Par. 2027 (applies only to stand-alone mode).	0...30	0	°C
2027	Boost Time Delay	Defines the time interval after which the set-point is increased as defined in Par. 2026 (applies only to stand-alone mode).	1...120	20	Min.
2028	Night Set-back Temp.	Used in heating mode Par. 2001 = 2 or 3. Establishes by how many degrees the delivery set-point is reduced when the RT (room thermostat/heat demand) contact is closed.	0...30	10	°C
2195	WWSD Enable	It is possible to enable/disable the shutdown of the entire system due to high external temperatures, both CH and ZH.	Enabled/Disabled	Enabled	
2035	DHW mode	Establishes the domestic hot water circuit's operation mode. 0 = Disabled 1 = Tank + sensor 2 = Tank + thermostat	0,1,2	0	
2036	DHW Tank Hyst. Down	Defines the hysteresis to initiate the domestic hot water demand.	0...20	5	°C
2037	DHW Tank Hyst. Up	Defines the hysteresis to stop the domestic hot water demand.	0...20	5	°C
2038	DHW Tank Supply Extra	Defines the primary circuit's set-point increase in degrees compared to the temperature set for the domestic hot water tank.	0...30	15	°C

MENU INSTALLER / MANUFACTURER

Par. No.	Parameter name	Description	Range	Default setting	UM
2042	DHW Priority	Defines the priority type: 0 = Time: time priority between the two circuits defined by Par. 2043; 1 = Off: priority for CH; 2 = On: priority for DHW; 3 = Parallel: parallel priority managed on the basis of the primary circuit's temperature compared to the heating circuit's set-point.	0...3	2 = On	
2043	DHW Max. Priority Time	Establishes the time in minutes during which priority is alternatively allocated to the DHW and CH circuits when Par. 2043 is set to "time" mode.	1...255	30	Min.
2044	DHW Pump Overrun	Establishes the overrun time in seconds for the domestic hot water mode with the boiler in stand-alone operation; cascaded operation defines the module's overrun after switch-off due to thermoregulation.	0...900	60	Sec.
2048	DHW tank set-point	Establishes the DHW storage tank set-point.	40...71	50	°C
2064	PreHeat Mode	"reserved"	Off, Comfort, Eco, Anti-Fr	Off	
2091		DHW maximum setpoint	50...90	71	°C
2092	Fan Speed Maximum	Defines the number of fan rpm at max. power (it depends on the model).	0...12750	Defined by Par. 9098	RPM
2093	Fan Speed Minimum	Defines the number of fan rpm at minimum power (it depends on the model).	0...12750	Defined by Par. 9098	RPM
2094	Fan Speed Ignition	Defines the number of fan rpm when the boiler is switched on (it depends on the model).	0...12750	Defined by Par. 9098	RPM
2109		Defines the offset of the calculated set point on climatic mode (Par. 2001= 1). Makes a climatic curve compensation.	Off, -10...10	0	
2110		Defines the minimum delivery temperature at which the system operates in both heating and DHW mode.	20...50	30	°C
2111		Defines the maximum delivery temperature at which the system operates in both heating and DHW mode.	50...90	80	°C
2112		Sets the value in degrees below the set-point at which the burner switches on again for thermoregulation.	0...20	5	°C
2113		Defines the domestic hot water circuit's % max. power.	50...100	100	%
2114		Defines the domestic hot water circuit's % minimum power.	1...30	1	%
2115		Defines the Accumulation sanitary Setpoint in mode 1	40...71	50	°C
2116	Prog. Input 1.	0 = Disabled 1 = Water pressure sensor 2 = CH flow switch 3 = Flue pressure switch	0,1,2,3	Defined by Par. 9097	
2117	Prog Input 2.	0 = Disabled 1 = DHW flow sensor 2 = DHW flow switch 3 = CH flow sensor	0,1,2,3	Defined by Par. 9097	
2118	Prog Input 3.	0 = Disabled 1 = Drain switch 2 = Gas pressure switch	0,1,2	Defined by Par. 9097	
2120	Prog Input 5.	0 = Disabled 1 = T_Return sensor 2 = Extern switch	0,1,2	Defined by Par. 9097	
2121	Prog Input 6.	0 = Disabled 1 = T_Flue sensor 2 = Flue switch 3 = APS switch	0,1,2,3	Defined by Par. 9097	
2122	Prog Input 7.	0 = Disabled 1 = T_Flue_2 sensor 2 = T_Flue_2 + Bl. Flue 3 T_System sensor 4 = Blocked Flue switch 5 Cascade Sensor	0,1,2,3,4,5	Defined by Par. 9097	
2123	Prog Input 8.	0 = Disabled 1 = T_DCW sensor 2 = Water pressure switch	0,1,2	Defined by Par. 9097	
2188	Prog. Input 9.	0 = Disabled 1 = DHW sensor 2 = Zone sensor	0,1,2	Defined by Par. 9097	
2124	Prog. Input RT.	0 = Disabled 1 = Enabled	0,1	Defined by Par. 9097	

MENU INSTALLER / MANUFACTURER

Par. No.	Parameter name	Description	Range	Default setting	UM
2125	Prog. Output 1.	0 = Disabled 1 = General Pump 2 = CH Pump 3 = DHW Pump 4 = System Pump 5 = Cascade Pump 6 = Alarm Relay 7 = Filling Valve 8 = LPG Tank 9 = External Igniter 10 = Air Damper 14 = Alarm Burner CC 15 = Status Burner CC 16 = Zone pump 17 = Mixing valve open 18 = Mixing valve closed 19 = Anti-Legionella 20 = LPG Tank Cascade	0,1,2,3,4,5,6,7,8,9,10,14,15,16,17,18,19,20	Defined by Par. 9097	
2126	Prog. Output 2.	0 = Disabled 1 = General Pump 2 = CH Pump 3 = DHW Pump 4 = System Pump 5 = Cascade Pump 6 = Alarm Relay 7 = Filling Valve 8 = LPG Tank 9 = External Igniter 10 = Air Damper 14 = Alarm Burner CC 15 = Status Burner CC 16 = Zone pump 17 = Mixing valve open 18 = Mixing valve closed 19 = Anti-Legionella 20 = LPG Tank Cascade	0,1,2,3,4,5,6,7,8,9,10,14,15,16,17,18,19,20	Defined by Par. 9097	
2127	Prog. Output 3.	0 = Disabled 6 = Alarm relay 10 = Air Damper 11 = External Igniter	0,1,2,3,4,5,6,7,8,9,10,11,12	Defined by Par. 9097	
2128	Prog. Output 4.	0 = Disabled 1 = General Pump 2 = CH Pump 3 = DHW Pump 4 = System Pump 5 = Cascade Pump 6 = Alarm Relay 7 = Filling Valve 8 = LPG Tank 9 = External Igniter 10 = Air Damper 14 = Alarm Burner CC 15 = Status Burner CC 16 = Zone pump 17 = Mixing valve open 18 = Mixing valve closed 19 = Anti-Legionella 20 = LPG Tank Cascade	0,1,2,3,4,5,6,7,8,9,10,14,15,16,17,18,19,20	Defined by Par. 9097	
2187	Prog. Output 5.	0 = Disabled 1 = General Pump 2 = CH Pump 3 = DHW Pump 4 = System Pump 5 = Cascade Pump 6 = Alarm Relay 7 = Filling Valve 8 = LPG Tank 9 = External Igniter 10 = Air Damper 14 = Alarm Burner CC 15 = Status Burner CC 16 = Zone pump 17 = Mixing valve open 18 = Mixing valve closed 19 = Anti-Legionella 20 = LPG Tank Cascade	0,1,2,3,4,5,6,7,8,9,10,14,15,16,17,18,19,20	Defined by Par. 9097	

MENU INSTALLER / MANUFACTURER					
Par. No.	Parameter name	Description	Range	Default setting	UM
2129	Flow sensor	Defines the type of flow sensor used.	Bitron, Huba: DN8, DN10, DN15, DN15, DN20, DN25	Huba DN25	
2130	Flow Scaling Factor	Flow rate scaling factor	0...25.5	3.2	rpm/l
2131	Min. Pressure	CH minimum pressure	Off, 0.3...5.0	0.1	bar
2132	Pressure Fill Hyst.	Filling hysteresis	Off, 0.2...5.0	0.5	bar
2133	Mod. Pump dT	Defines the delta T set for the operation of the modulating circulator.	5...40	15	°C
2134	Mod. Pump Start Time	Defines the time in seconds from the moment the burner is switched on to start the modulation of the circulator and obtain the delta T specified in Par. 2133.	0...255	120	Sec.
2135	Mod. Pump Type	Defines the PWM circulator model installed. 0 = Wilo 1 = Salmson 2 = Grundfos	0,1,2	2 = Grundfos	
2136	Mod. Pump Mode	Defines whether the boiler's circulator operates in modulating mode or at a set speed (as a percentage of maximum speed).	On/Off Modulating Fixed 20...100%	Modulating	
2137	Mod. Pump Min Pwr	Defines the percentage of speed that sets the minimum speed that the circulator can reach during modulation.	0...100	30	%
2139	Dair active	Activates bleeding the system's air. To activate air bleeding, it is necessary to switch on the boiler and change the parameter from "No" to "Yes". Wait for one minute. Switch off and restart. At this stage, when it is restarted the boiler will initiate the automatic bleeding procedure (lasting around 20 minutes). With the parameter set to "Yes", the procedure is carried out each time the boiler is switched off and restarted using its master switch. The value must be set to "No" if you do not wish to initiate the bleeding procedure when the thermal module is switched on.	Yes, No	No	
2140	Minimum Flow	Defines the flow rate below which the boiler is switched off. The value varies depending on the model.	0.0...100	Depends on boiler model	l/min
2141		Nominal flow rate	0...10	0	l/min
2196	HX flow timeout	If the minimum flow rate is not reached within the timeout, error 163 (LOWEXFLOW_PROTECTION) will be generated which will also cause the end of prepurge.	4...100	18	Sec.
2185	Calc. set-point off-set	It is possible to shift the climatic curve up and down. The calculated setpoint can be increased or decreased with a maximum of 10°C.	-10...10	0	°C
2201		Enable Heating	Enable/Disable	Enable	-
2202		Enable Heating	Enable/Disable	Enable	-
2203		Sets the Service reminders	Off/On/Reset	Off	-
2204		Days for Service	30/35/40.../1275	1000	days
2205		Anti-freeze protection activation setting	Enable/Disable	Disable	
2184	N. active burner in DHW	With this setting it is possible to set the number of burners that are used for cascade DHW.	0...16	16	
2190	Outd. Comp. Fact.		0...100	0	%
2191	Fan Type	Defines the type of fan installed in the boiler.	0...15	Defined by Par. 9097	
2006	Flue Temp. Limit	Sets the activation temperature when the maximum flue gas temperature is exceeded. When the flue gas temperature is higher than a set value, the module switches off and an error message is generated. When the flue gas temperature is in the interval between (Par. 2006) -5°C and Par. 2006, the module reduces its power in a linear way until it reaches minimum power when the temperature measured is equal to Par. 2006.	10...120	100	°C
2012	Hx diff. Minimum	Sets the value of the temperature difference (Delta T) between the module's delivery and return temperature. For a Delta T value ranging between Par. 2012 and (Par. 2012) +8°C, the module reduces its power in a linear fashion until it reaches the minimum power. The minimum power is maintained until reaching (Par. 2012) +8°C+5°C, after which the module switches off for a period of time equal to the value attributed to Par. 2013; at the end of this time interval, the module switches on again.	10...60	40	°C
2013	Hx Diff. Max. Wait Time	Defines the restart time after reaching the Delta T limit between delivery and return.	10...250	30	Sec.

MENU INSTALLER / MANUFACTURER					
Par. No.	Parameter name	Description	Range	Default setting	UM
2016	CH PID P	Defines the proportional parameter for modulation during heating operation.	0...1275	100	
2017	CH PID I	Defines the modulation integral term during heating operation.	0...1275	250	
2018	CH PID D	Defines the modulation derivative term during heating operation.	0...1275	0	
2039	DHW Tank Supp Hyst Dn	Defines the primary circuit's restart hysteresis in modes 1 and 2 of domestic hot water (valid both for cascade and stand-alone applications).	0...20	5	°C
2040	DHW Tank Supp Hyst Up	Defines the primary circuit's shut-off hysteresis in modes 1 and 2 of domestic hot water (valid both for cascade and stand-alone applications).	0...20	5	°C
2041	DHW Tank Hold Warm	Defines the value referred to the Delta T of the tank for maintenance purposes. E.g.: if it is set on 3, when the tank has a set point lowered of 3 degrees, the module turns on at the minimum to allow maintenance till the set point plus hysteresis. If this parameter is equal to Par. 2036, this function is inactivated and the thermal module starts at the maximum sanitary power.	0...10	5	°C
2045	DHW Tank PID P	Defines the proportional term for modulation during operation of the DHW storage tank.	0...1255	100	
2046	DHW Tank PID I	Defines the integral term for modulation during operation of the DHW storage tank.	0...1255	500	
2047	DHW Tank PID D	Defines the derivative term for modulation during operation of the DHW storage tank.	0...1255	0	
9192	Appliance Model	Defines the boiler model.	1...4		
9097	IO Configuration	Supports uploading the values of Par. from 2116 to 2128 from a set of pre-defined rpm values that defines the configuration of the boiler's inputs and outputs.	1...53		
9098	Appliance Settings	Supports uploading the values of Par. 2092, 2093 and 2094 from a set of pre-defined rpm values that identifies the boiler type.	1...85		
CONF	Configuration Confirmed	Configuration confirmed	Si/No	No	
Code		Enter menu password INSTALLER / MANUFACTURER			

NOTE:

The use and configuration of the parameters 9192 and CONF are explained in detail in the paragraphs "Display board replacement" e "Control board replacement".

3 COMMISSIONING AND MAINTENANCE

3.1 Preparing for initial startup

The thermal module **POWER MAX Borella** must be commissioned by Technical Assistance Centre **Borella**, after which step the appliance may operate automatically.

Perform the following checks before starting up the boiler:

- Check that the fuel shut-off cock and heating system shut-off cock are open
- Check that the central heating circuit pressure gauge shows a pressure over **1 bar** with the system cold. Check also that the circuit is properly de-aerated
- Check that the expansion vessel is correctly pre-charged
- the electric connections have been made correctly
- Check that the flue and air vents are made to applicable laws and standards

3.2 Initial startup

- Switch the system's master switch to the ON position and the thermal module's master switch to (I).

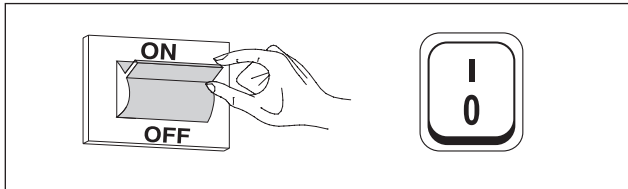

3.2.1 Switching the appliance on and off

Once the device is on, the initialization process starts for about one minute during which no operations are allowed.

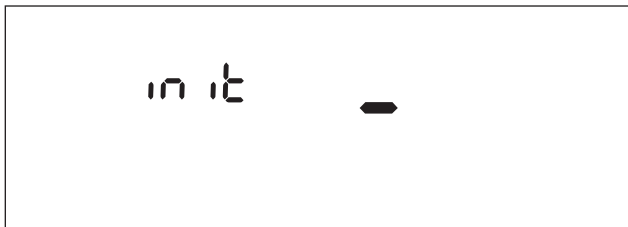

Once the process is completed, parameters can be set for heating and DHW production.

To switch off the appliance, use the "ON/OFF" switch.

⚠ Never power off the appliance before switching the master switch to the "0" position.

⚠ Never switch off the appliance with the master switch if a request is active. Always make sure that the appliance is in stand-by before switching the main switch.

Example of display on stand-by (outdoor probe is not connected)



Example of display on stand-by (outdoor probe is connected).

Probe available as a accessory.

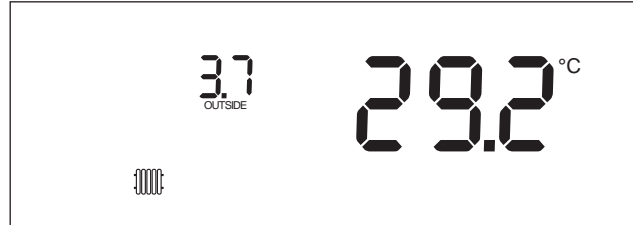

3.2.2 Password access

It is necessary to enter the password to access the INSTALLER / MANUFACTURER parameters

- See "Navigation Menu INSTALLER / MANUFACTURER" for the correct procedure.

3.2.3 Setting the heating parameters

The parameter 2001 establishes the thermal module's various heating operation modes.

Mode 0

(Operation with room thermostat/heat demand and fixed heating setpoint)

In this mode, the thermal module operates with a fixed setpoint (controlled by the parameter 2003) based on whether the room/heat demand thermostat's contact is closed or not.

The setpoint can be set directly without entering the parameters list as indicated in paragraph "USER navigation MENU".

the set point can be set within a minimum and maximum value as indicated respectively on Par. 2023 and 2024 as shown in the figure.

The outdoor temperature sensor (accessory) is not required and if connected the outdoor temperature that is measured does not influence the setpoint that has been set.

The parameters regulating such temperature are:

Par. No.	Description
2003	Sets the desired flow temperature with heating mode. Active for the heating mode Par. 2001 = 0 or 3
2023	Limits the minimum value that can be assigned to the set-point in heating mode (does not apply to heating mode 4).
2024	Limits the maximum value that can be assigned to the set-point in heating mode (does not apply to heating mode 4).

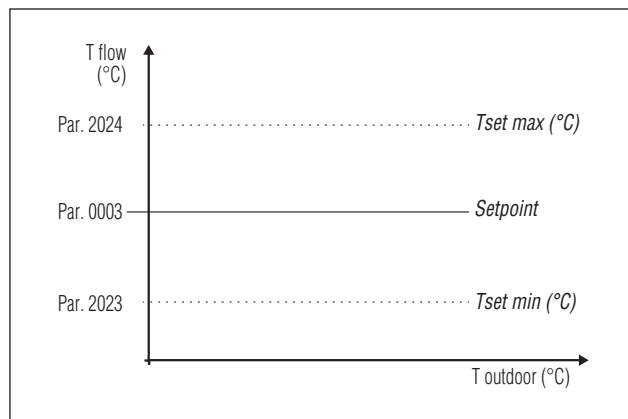

Mode 1

(Climatic functioning with room/heat demand thermostat, variable set point according to the outdoor temperature)

In this case the thermal module operates with a variable set-point depending on outdoor temperature based on a climatic curve defined by the following parameters:

Par. No.	Description
2109	Defines the value of the set point calculated on climatic mode (Par. 2001 = 1).
2019	Establishes the max. set-point at the minimum outdoor temperature for climatic regulation

Par. No.	Description
2020	Establishes the minimum outdoor temperature to which the maximum set-point can be associated for climatic regulation
2021	Establishes the minimum set-point at the maximum outdoor temperature for climatic regulation
2022	Establishes the maximum minimum outdoor temperature to which the minimum set-point can be associated for climatic regulation
2023	Limits the minimum value that can be assigned to the set-point in heating mode (does not apply to heating mode 4).
2024	Limits the maximum value that can be assigned to the set-point in heating mode (does not apply to heating mode 4).
2025	Defines the temperature at which climatic regulation is switched off

Display on climatic mode

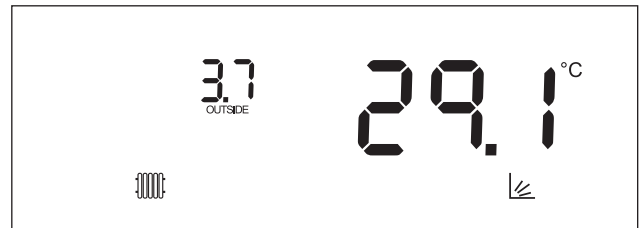

The demand is activated when the room/heat demand thermostat's contact is closed provided that outdoor temperature does not exceed the value set by the parameter 2025. If the outdoor temperature is higher than the one set on parameter 2025, the burner is stopped even if there is a heat demand.

! If the outdoor temperature sensor (accessory) is not detected (not installed or damaged) the system provides a warning: no. 202

The presence of the warning does not stop the thermal module allowing a heat request to be carried out at the maximum setpoint set on the climatic regulation.

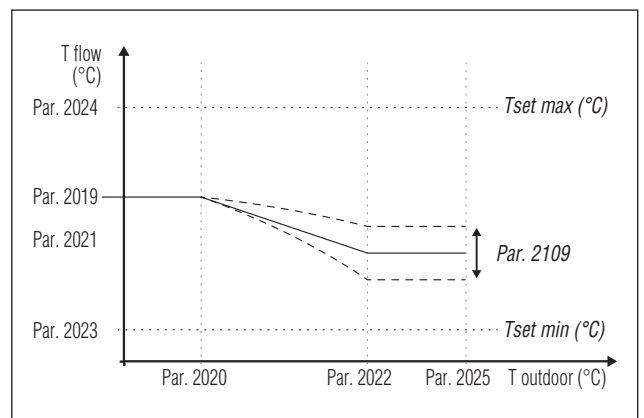

Mode 2

(Working on climatic mode with attenuation controlled by a room/heat demand thermostat, variable set point according to the outdoor temperature)

In this case the thermal module operates with a set-point defined by the climatic curve (which can be set in the same way as described in Mode 1) depending on outdoor temperature. Heat demand is actioned independently from whether the room/heat demand thermostat's contact is closed and stops only when the outdoor temperature is greater than the one defined by the parameter 2025.

In this mode the parameter 2028 defines by how many degrees the set-point is decreased (attenuation) when the room/ heat demand thermostat's contact is opened.

Par. No.	Description
2109	Defines the value of the set point calculated on climatic mode (Par. 2001 = 1).
2019	Establishes the max. set-point at the minimum outdoor temperature for climatic regulation
2020	Establishes the minimum outdoor temperature to which the maximum set-point can be associated for climatic regulation
2021	Establishes the minimum set-point at the maximum outdoor temperature for climatic regulation
2022	Establishes the maximum minimum outdoor temperature to which the minimum set-point can be associated for climatic regulation
2023	Limits the minimum value that can be assigned to the set-point in heating mode (does not apply to heating mode 4).
2024	Limits the maximum value that can be assigned to the set-point in heating mode (does not apply to heating mode 4).
2025	Defines the temperature at which climatic regulation is switched off
2028	Use the heating mode Par. 2001= 2 or 3. Defines how many degrees the flow set point is lowered.

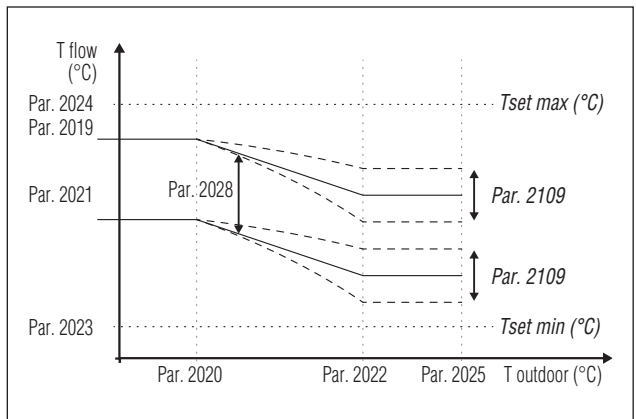

Mode 3

(Continuous fixed set-point operation with attenuation controlled by room/heat demand thermostat)

In this mode the fixed set-point is adjusted in the same way as described for Mode 0. The difference consists in the fact that the demand is always active and the set-point is decreased (attenuation) by the value defined by the parameter 2028 when the room/heat demand thermostat's contact is opened.

Par. No.	Description
2003	Sets the desired flow temperature with heating mode. Active for the heating mode Par. 2001 = 0 or 3
2023	Limits the minimum value that can be assigned to the set-point in heating mode (does not apply to heating mode 4).
2024	Limits the maximum value that can be assigned to the set-point in heating mode (does not apply to heating mode 4).
2028	Use the heating mode Par. 2001= 2 or 3. Defines how many degrees the flow set point is lowered.

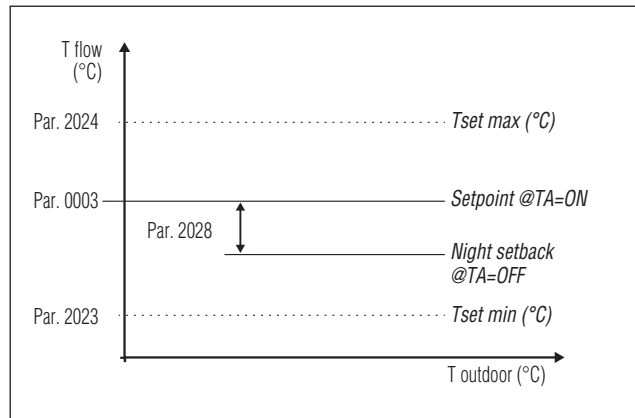

⚠ The outdoor temperature sensor (accessory) is not required and if connected the outdoor temperature that is measured does not influence the setpoint that has been set.

Mode 4

(Set-point adjustment based on a 0-10V analogical input)
The maximum and minimum set-point values are defined respectively by Par. 2111 and 2110.

Par. No.	Description
2110	Sets the minimum delivery temperature value in heating mode (Par. 2001) = 4.
2111	Sets the maximum delivery temperature value in heating mode (Par. 2001) = 4.

The operation set-point is adjusted on the basis of the following curve:

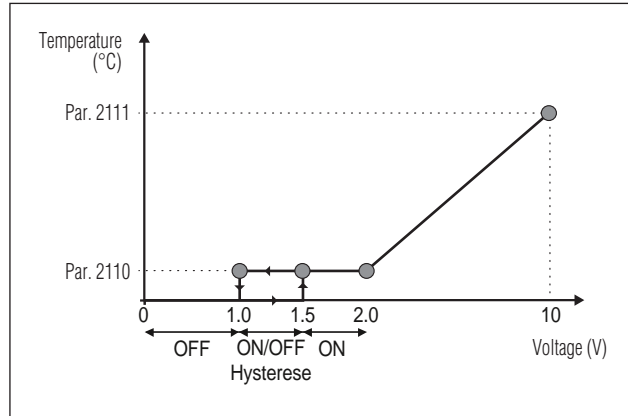

The maximum and minimum set-point values are defined respectively by Par. 2111 and 2110.
When the input voltage value exceeds 1.5V, the demand is triggered (at the minimum set-point).
For voltage values ranging from 2 to 10, the set-point varies in a linear fashion from the minimum through to the maximum value. If the voltage is decreased from 10 to 2, the set-point decreases in a linear fashion and maintains the minimum value between 2 and 1V. For values lower than 1 V the demand stops.

3.2.4 Setting the domestic hot water parameters

The parameter 2035 defines the various operation modes of the thermal module for DHW production

Mode 0

(No production of domestic hot water)
In this mode the thermal module will work only for the heating circuit (see paragraph "Setting the heating parameters")

Mode 1

(DHW production with storage tank and storage cylinder probe)
In this mode, the thermal module is activated when the temperature recorded by the storage cylinder probe falls below the DHW setpoint by an amount equal to the hysteresis value and is deactivated when the temperature rises above the DHW setpoint by the value of the hysteresis.

The parameters that control DHW production are the following:

Par. No.	Description
2036	Defines the hysteresis to initiate the domestic hot water demand.
2037	Defines the hysteresis to stop the domestic hot water demand.
2038	Defines the primary circuit's set-point increase in degrees compared to the temperature set for the domestic hot water tank.
2039	Defines the primary circuit's restart hysteresis in modes 1 and 2 of DHW (valid both for cascade and stand-alone applications).
2040	Defines the primary circuit's shut-off hysteresis in modes 1 and 2 of DHW (valid both for cascade and stand-alone applications).
2041	Defines the value referred to the Delta T of the tank for maintenance purposes. E.g.: if it is set on 3, when the tank has a set point lowered of 3 degrees, the module turns on at the minimum to allow maintenance till the set point plus hysteresis. If this parameter is equal to 2036, this function is inactivated and the thermal module starts at the maximum sanitary power.
2048	Establishes the DHW storage tank set-point.

The setpoint can be set directly without entering the parameters list as indicated in paragraph "USER navigation MENU".

Mode 2

(DHW production with storage tank controlled by a thermostat)

In this case the thermal module is activated when the contact in boiler's thermostat is closed and is deactivated when the latter is opened.

The parameters that control DHW production are the following:

Par. No.	Description
2038*	Defines the primary circuit's set-point increase in degrees compared to the temperature set for the domestic hot water tank.
2039	Defines the primary circuit's restart hysteresis in modes 1 and 2 of DHW (valid both for cascade and stand-alone applications).
2040	Defines the primary circuit's shut-off hysteresis in modes 1 and 2 of DHW (valid both for cascade and stand-alone applications).
2048	Establishes the DHW storage tank set-point.

(*) Parameter 2038 is active on such mode even if the tank probe is not installed and it influences the flow temperature of the module.

It can be used to limit the difference between the flow and set temperature on the tank thermostat so that the system efficiency is maximized.

The setpoint can be set directly without entering the parameters list as indicated in paragraph "USER navigation MENU".

Priority setting

The parameter 2042 sets the priorities between the DHW and CH circuit.

Four modes are envisaged:

- 0 Time:** timed priority between the two circuits. In the event of a simultaneous demand, initially the domestic hot water circuit is made to operate for a number of minutes equal to the value assigned to the parameter 2043. At the end of this time period, the CH circuit is operated (also for the same amount of time) and so on until demand for one or the other circuit stops
- 1 Off:** priority given to the heating circuit
- 2 On:** priority allocated to the DHW circuit
- 3 Parallel:** simultaneous operation of both circuits provided that the delivery temperature requested by the DHW circuit is lower than or equal to the setpoint requested by the heating circuit. When the temperature requested by the DHW circuit exceeds the heating setpoint, the circulation pump of the heating is turned off and priority is switched to the DHW.

Anti-Legionella function

This function is only on when the circuit for DHW production is on mode 1.

The anti-legionella function is activated automatically on the module start up and it is repeated every 7 days (this parameter can be modified).

If the appliance is electrically discharged, the cycle described below will be repeated at the next start.

During the cycle of anti-legionella the thermal module generates a demand for the sanitary gathering set with a pre-set set point of 60 ° C (not modifiable). Once the temperature of 60 ° C is reached, the temperature is maintained for 30 minutes during which the system checks that the temperature of the probe does not drop below 57°C. At the end of this time, the anti-legionella function is terminated and the normal operation of the thermal module is reset.

Anti-legionella mode has the priority over other requests regardless of the several parameters setting.

When the function is active, the message "ALE9" is displayed beside the heater temperature and the icon  blinks.



3.3 Checks during and after initial start-up

When the appliance it started, it must be checked by stopping and then restarting the thermal module in the following way:

- Set the operating mode of the thermal module in heating to 0 (Par. 2001) e and close the RT input to generate a heat request
- If required, increase the set-point value (CH → Heating Set-point)

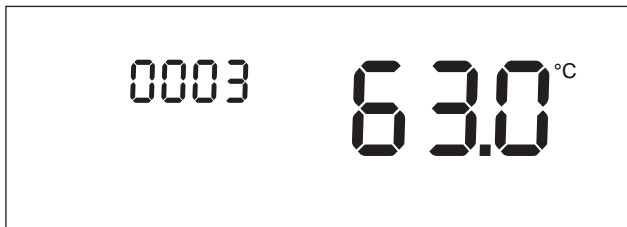

- Make sure that all the pumps in the system are free and rotate in the right direction

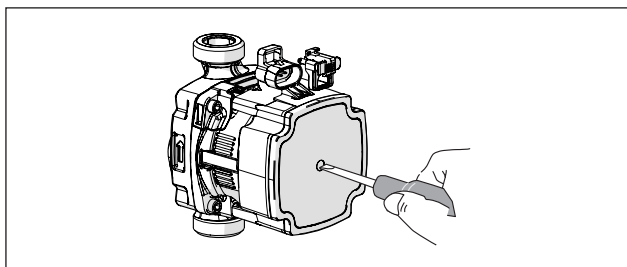

- Check the full stop of the thermal module and the heat demand by opening the "RT" contact (OFF).
- Check that the thermal module has come to a complete stop by setting the main switch of the equipment and the main switch of the system to "off".

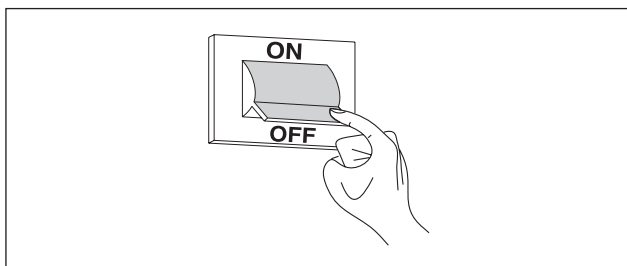

If all conditions are met, power the thermal module by setting the system's and the appliance's master switches to "On" and test combustion products (see Paragraph "Adjustments").

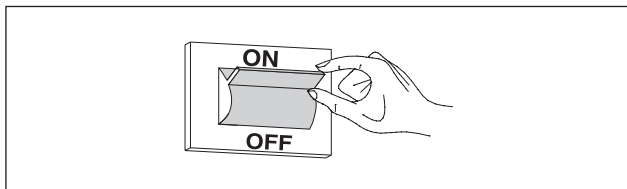

SUPPLY GAS PRESSURE CHECK

- Turn the main system switch "off"
- Remove the locking screws and the panel's front side
- Loosen by about two turns the pressure inlet screw (1) upstream of the gas valve and connect the pressure gauge

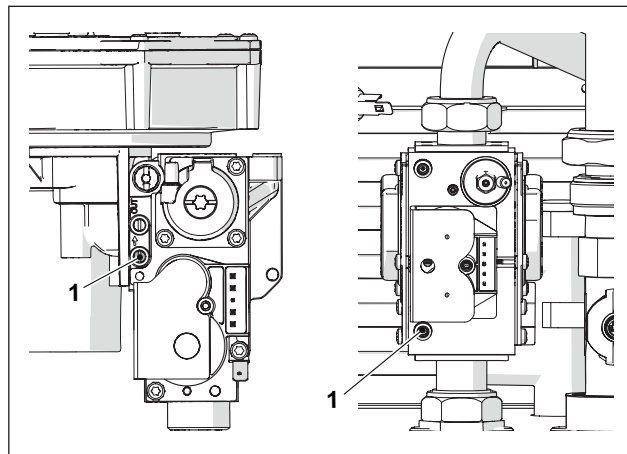

- Power the thermal module by setting the system's and the appliance's master switches to "On".

Set Par. 0200 on "Hi" by using "PROG +" and "PROG -" and press "MENU/RESET" to confirm.



DESCRIPTION	G20	G30	G31	
Wobbe index	45,7	80,6	70,7	MJ/m ³
Nominal supply pressure	20	28-30	37	mbar

After the checks:

- select "OFF" using "PROG +" and "PROG -" and press "MENU/RESET" to confirm.
- Disconnect the pressure gauge and tighten again the pressure test point screw (1) upstream from the gas valve.



- Fulfil the operations, place back the front panel and lock the locking screws.

3.4 Error List

When a display has a technical fault, a numeric error code appears that will enable the maintenance operator to identify the possible cause.

There are 3 categories of errors:

- 1 Permanent: errors that require a manual reset
- 2 Temporary: errors that are automatically reset once the cause that generated them is removed or stopped
- 3 Notices: simple warnings that do not block the appliance's operation

3.4.1 Permanent Errors

Nr.	Error	Description	Checks	Solutions
0	E2PROM_READ_ERROR	Internal software error		Control board replacement
1	IGNIT_ERROR	Three unsuccessful ignition attempts in a row	Check gas supply pressure Check ignition spark Correct amount of air Check for voltage at the gas valve	If the gas supply pressure is incorrect, it must be adjusted to the correct pressure If spark is not present check for correct ignition electrode position If the combustion air pressure is incorrect, inspect the vent system and eliminate any obstructions If the voltage at the gas valve is not the same as the boiler power supply, replace the control board
2	GV_RELAY_ERROR	Failure detected in the GV (Gas Valve) relay	Check the integrity of the wire connections between gas valve and control board	If wires are damaged, replace them If the wiring is intact, replace the gas valve or the control board
3	SAFETY_RELAY_ERROR	Internal control board error		a) If the error appears during operation, replace the control board b) If the error appears when the boiler is starting up (using main switch), check that the limit thermostat (and wiring) is integral
4	BLOCKING_TOO_LONG	Control had a blocking error for more than 20 hours	Press RESET button to display the Blocking error description	Remove the cause of the Blocking error
5	FAN_ERROR_NOT_RUNNING	Fan is not running for more than 60 seconds	Check that the fan is connected to the power supply Check PWM connection of the fan	If there is no voltage, replace the control board If no PWM signal is present, replace control board Replace the fan
6	FAN_ERROR_TOO_SLOW	Fan runs too slow for more than 60 seconds		
7	FAN_ERROR_TOO_FAST	Fan runs too fast for more than 60 seconds		
8	RAM_ERROR	Internal software error		Control board replacement
9	WRONG_EEPROM_SIGNATURE	Contents of Eeprom is not up to date		Control board replacement
10	E2PROM_ERROR	Wrong safety parameters in Eeprom		Control board replacement
11	STATE_ERROR	Internal software error		Control board replacement
12	ROM_ERROR	Internal software error		Control board replacement
15	MAX_TEMP_ERROR	The external overheat protection is enabled or the T_Supply sensor measures a temperature of over 100°C (212°F)	Check the pump to verify the flow circulation Check if the valves on hydraulic circuit are open Check the safety thermostat	Change the pump or restart it Open the valves on hydraulic circuit Replace the safety thermostat
16	FLUE_GAS_ERROR	Flue temperature exceeded the maximum flue temperature		

Nr.	Error	Description	Checks	Solutions
17	STACK_ERROR	Internal software error		Control board replacement
18	INSTRUCTION_ERROR	Internal software error		Control board replacement
19	ION_CHECK_FAILED	Internal software error		Control board replacement
20	FLAME_OUT_TOO_LATE	Flame still present 10 seconds after closing the gas valve		Replace the gas valve
21	FLAME_BEFORE_IGNIT	Flame is detected before ignition		Replace the gas valve
22	Loss of flame	Flame lost three times during a request		
23	CORRUPTED_ERROR_NR	Error code RAM byte was corrupted to an unknown error code		
29	PSM_ERROR	Internal software error		
30	REGISTER_ERROR	Internal software error		Control board replacement

3.4.2 Temporary Errors

Nr.	Error	Description	Checks	Solutions
100	WD_ERROR_RAM	Internal software error		Control board replacement
101	WD_ERROR_ROM	Internal software error		Control board replacement
102	WD_ERROR_STACK	Internal software error		Control board replacement
103	WD_ERROR_REGISTER	Internal software error		Control board replacement
106	REFHI_TOO_HIGH / REFHI_TOO_LOW	Internal software error		Control board replacement
107	REFHI_TOO_HIGH / REFHI_TOO_LOW	Internal software error		Control board replacement
108	REFHI_TOO_HIGH / REFHI_TOO_LOW	Internal software error		Control board replacement
109	REFHI_TOO_HIGH / REFHI_TOO_LOW	Internal software error		Control board replacement
110	REFHI_TOO_HIGH / REFHI_TOO_LOW	Internal software error		Control board replacement
111	REFHI_TOO_HIGH / REFHI_TOO_LOW	Internal software error		Control board replacement
112	REFHI_TOO_HIGH / REFHI_TOO_LOW	Internal software error		Control board replacement
113	REFHI_TOO_HIGH / REFHI_TOO_LOW	Internal software error		Control board replacement
114	FALSE_FLAME	Flame is detected in a state in which no flame is allowed to be seen.		Control board replacement
115	LOW_WATER_PRESSURE_ERROR	Low water pressure error		
118	WD_COMM_ERROR	Watchdog communication error		Control board replacement
119	RETURN_OPEN	Return sensor open	Check the integrity of the wire connections Check the return temperature sensor	If the wiring is damaged, replace it Verify that the temperature sensor has the correct resistance values. If values are incorrect sensor must be replaced.
120	SUPPLY_OPEN	Supply sensor open	Check the integrity of the wire connections Check the return temperature sensor	If the wiring is damaged, replace it Verify that the temperature sensor has the correct resistance values. If values are incorrect sensor must be replaced.

Nr.	Error	Description	Checks	Solutions
122	DHW_OPEN	DHW sensor open	Check the integrity of the wire connections Check the DHW temperature sensor	If the wiring is damaged, replace it Verify that the temperature sensor has the correct resistance values. If values are incorrect sensor must be replaced.
123	FLUE_OPEN	Flue sensor open		
126	RETURN_SHORTED	Return sensor shorted	Check the integrity of the wire connections Check the return temperature sensor	If the wiring is damaged, replace it Verify that the temperature sensor has the correct resistance values. If values are incorrect sensor must be replaced.
127	SUPPLY_SHORTED	Supply sensor shorted	Check the integrity of the wire connections Check the return temperature sensor	If the wiring is damaged, replace it Verify that the temperature sensor has the correct resistance values. If values are incorrect sensor must be replaced.
129	DHW_SHORTED	DHW sensor shorted	Check the integrity of the wire connections Check the DHW temperature sensor	If the wiring is damaged, replace it Verify that the temperature sensor has the correct resistance values. If values are incorrect sensor must be replaced.
130	FLUE_SHORTED	Flue sensor shorted	Check the integrity of the wire connections Check the Outdoor temperature sensor	If the wiring is damaged, replace it Verify that the temperature sensor has the correct resistance values. If values are incorrect sensor must be replaced.
133	Net Freq Error	Net. freq. error detected by the watchdog		
134	RESET_BUTTON_ERROR	Too many resets in a short time period		
163	T_SELECTION1_OPEN	Heat exchanger's flow rate too low		
164	Boiler model not detected	Boiler model not set		

3.4.3 Warnings

Nr.	Error	Description	Checks	Solutions
200	CC_LOSS_COMMUNICATION	Cascade system: the burner of the managing module has lost the signal of one of the depending thermal module burner		
201	CC_LOSS_COMMUNICATION	Cascade system: the managing module has lost the signal of one of the depending thermal module		
202	OUTDOOR_WRONG	Outdoor sensor is open or shorted		
203	T_SYSTEM_WRONG	T_System sensor is open or shorted		
204	T_CASCADE_WRONG	T_Cascade sensor is open or shorted		
207	DHW sensor error	DHW sensor error		
208	Zone sensor error	Zone sensor error		
209	Boiler request disabled	Boiler request disabled		

3.5 Transformation from one gas type to another

The thermal module **POWER MAX** is supplied for operation with G20 (natural gas). However, it can be converted to operation with G30-G31 (LPG) using the dedicated accessory supplied as standard.



Forbidden in Belgium, Switzerland and Hungary.



Conversion can only be executed by Technical Assistance Centre or staff authorised by **Beretta**.



In order to execute the conversion, only follow the instructions in this manual and the provisions of safety standards.



If the information contained in these instructions is not properly performed or performed by personnel not properly trained, there is a potential risk of fuel leakage and/or carbon monoxide production resulting in personal injury and/or injury.



Conversion is not complete until all the control steps described in these instructions have been carried out.



After conversion, calibrate the CO₂ as shown in the "Adjustment" Paragraph.

Before making the transformation:

- make sure that the master switch and the thermal module's switch are in the "Off" position
- check that the fuel interception system valve is closed.

To install the accessory:

- remove the locking screw
- pull the front panel outwards and then to the top to decouple it from points A.

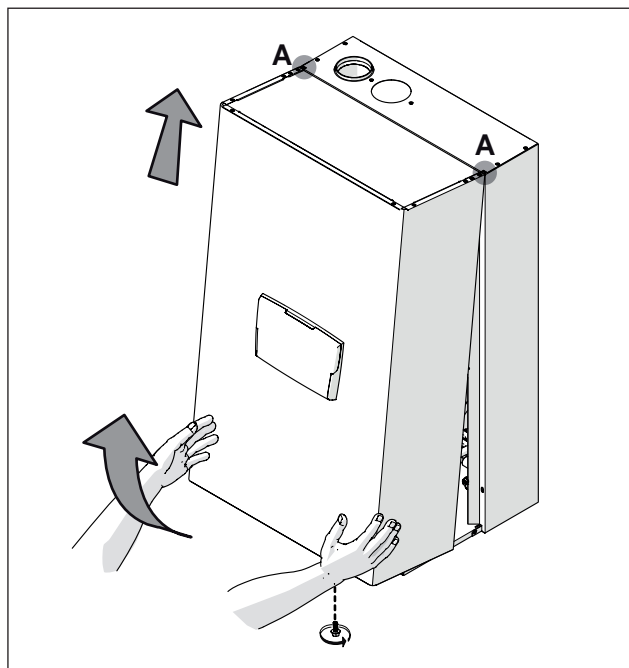

Versions **POWER MAX 65 P** to **POWER MAX 80 P**

- disconnect the electrical connections of the fan and the gas valve
- unscrew the swivel nut (2) on the gas pipe
- unscrew the fan screws to separate the fan from the heat exchanger
- unscrew the three screws (1) to separate the valve from the fan
- insert the related diaphragm (3) onto the gasket (4) without removing the gasket itself

Model	int. Ø (mm)
POWER MAX 65 P	6.25
POWER MAX 80 P	6.25

- check the integrity of the gasket (5); if necessary replace it
- retighten the valve
- retighten the fan screws
- screw the swivel nut (2) on the gas pipe
- reconnect the electrical connections of the fan and the gas valve

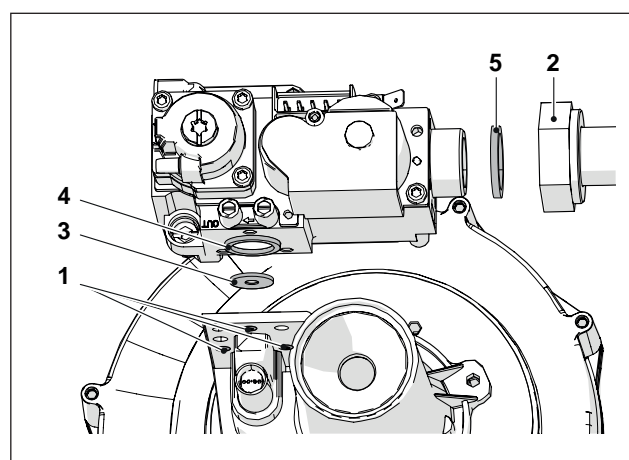

Versions POWER MAX 100 - POWER MAX 150

- disconnect the electrical connections of the fan and the gas valve
- unscrew the swivel nut (1) to remove the gas pipe from the fan
- loosen or unscrew the swivel nut on the gas valve to completely free the gas pipe
- insert the appropriate diaphragm (2) inside the brass curve

Model	int. Ø (mm)
POWER MAX 100	9
POWER MAX 110	9
POWER MAX 130	9.25
POWER MAX 150	8.75

- check the integrity of the gasket; replace it if necessary
- screw the swivel nut (1) to separate the gas pipe from the fan
- screw the swivel nut onto the gas valve to completely free the gas pipe
- reconnect the electrical connections of the fan and the gas valve

POWER MAX 100 - POWER MAX 110

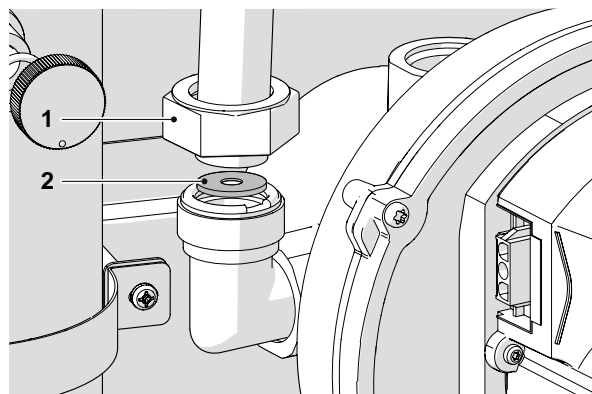

POWER MAX 130 - POWER MAX 150

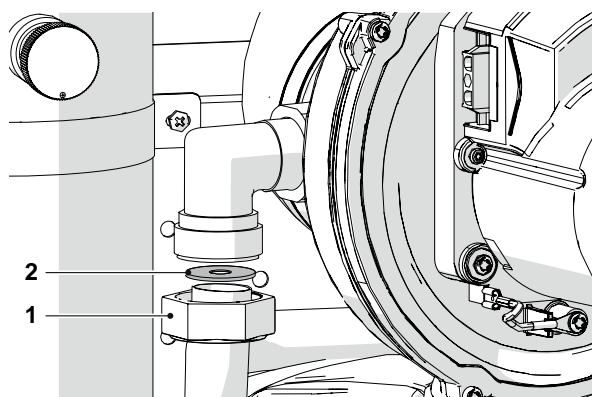

- if it is difficult to insert the diaphragm, unscrew the swivel nut (3) to completely free the gas pipe.

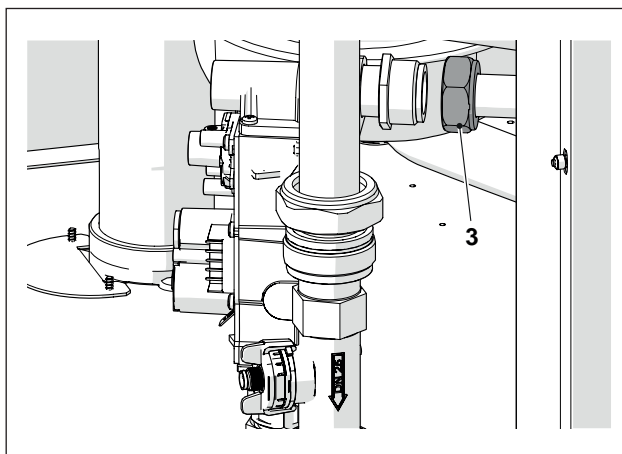

For all models

- Fulfil the operations, place back the front panel and lock the locking screws.
- Open the gas detection valve.
- Switch the electricity supply ON at the system's main switch and at the control panel.
- Make sure that there is no heat or DHW demand.

Enter the parameters and set the parameter 9098 as shown in the table below:

Model	Parameter 9098
POWER MAX 65 P	12
POWER MAX 80 P	10
POWER MAX 100	8
POWER MAX 110	6
POWER MAX 130	4
POWER MAX 150	2

Apply the adhesive for the feeding to G30-G31.

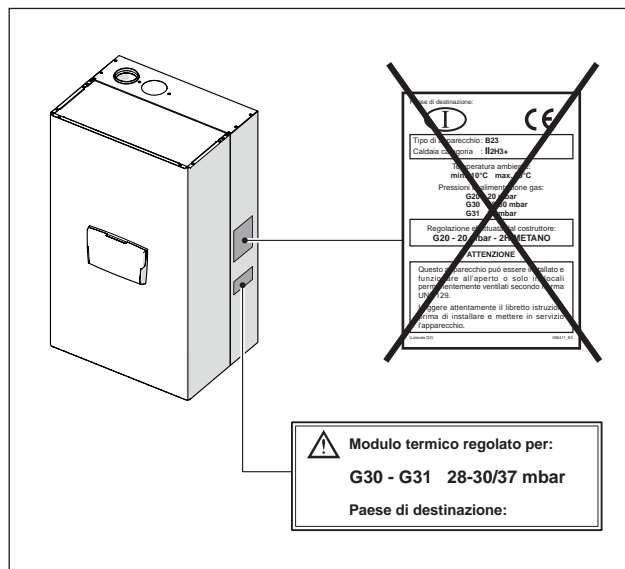

After installing the accessory, check all gaskets tightness. Carry out all calibration activities described in Paragraph "Adjustments". Restore the desired set points.

3.6 Adjustments

The thermal module **POWER MAX** is supplied for operation with G20 (methane gas), as indicated by the type plate, and has already been factory-calibrated by the manufacturer.

However, if it is necessary to repeat the adjustments, for example after non-scheduled maintenance, replacing the gas valve or after transformation from G20 gas to G30-G31 gas, or vice versa, proceed as described below.

⚠ Adjustments to maximum and minimum power must be performed in the indicated sequence and only by Technical Assistance Centre.

Before making the regulation:

- remove the locking screw
- pull the front panel outwards and then to the top to decouple it from points A.

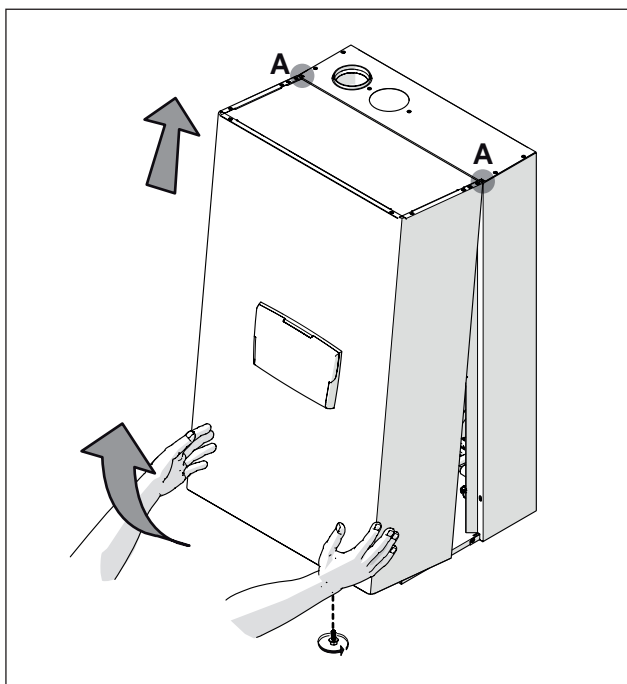

CO2 ADJUSTMENT AT MAXIMUM POWER

- Enter the menu "0000", select Par. 0200 and press "MENU/RESET" to confirm.
- Select "Hi" by using "PROG +" and "PROG -" and press "MENU/RESET" to confirm.
- the appliance will operate at maximum power.
- unscrew the cap (1) and insert the combustion analyser sensor
- adjust the CO₂ by using a screwdriver to adjust the screw (2) on the gas valve, until you reach the value shown in the table.

CO ₂ % maximum power	Gas type			
	G20	G25	G30	G31
POWER MAX 65 P	9 ^(+0.2) _(-0.4)	9 ^(+0.2) _(-0.2)	10,4 ^(+0.2) _(-0.2)	10,4 ^(+0.2) _(-0.2)
POWER MAX 80 P	9 ^(+0.2) _(-0.4)	9 ^(+0.2) _(-0.2)	10,4 ^(+0.2) _(-0.2)	10,4 ^(+0.2) _(-0.2)
POWER MAX 100	9 ^(+0.2) _(-0.4)	9 ^(+0.2) _(-0.2)	10,4 ^(+0.2) _(-0.2)	10,4 ^(+0.2) _(-0.2)
POWER MAX 110	9 ^(+0.2) _(-0.4) (*)	9 ^(+0.2) _(-0.2)	10,4 ^(+0.2) _(-0.2)	10,4 ^(+0.2) _(-0.2)
POWER MAX 130	9 ^(+0.2) _(-0.4)	9 ^(+0.2) _(-0.2)	10,4 ^(+0.2) _(-0.2)	10,4 ^(+0.2) _(-0.2)
POWER MAX 150	9 ^(+0.2) _(-0.4) (*)	9 ^(+0.2) _(-0.2)	10,4 ^(+0.2) _(-0.2)	10,4 ^(+0.2) _(-0.2)

⚠ (*) In Belgium, Switzerland and Hungary the value must be adjusted to 8.6^(+0.6)_(-0.6).

CO₂ ADJUSTMENT AT MINIMUM POWER

- Select "Lo" using "PROG +" and "PROG -" and press "MENU/RESET" to confirm.
- the appliance will operate at minimum power.
- Adjust the CO₂ using a screwdriver on the adjustment screw (3) on the fan unit, so as to obtain a value listed in the table.

Minimum power CO ₂ %	Gas type			
	G20	G25	G30	G31
POWER MAX 65 P	9 ^(+0.2) _(-0.4)	9 ^(+0.2) _(-0.2)	10,4 ^(+0.2) _(-0.2)	10,4 ^(+0.2) _(-0.2)
POWER MAX 80 P	9 ^(+0.2) _(-0.4)	9 ^(+0.2) _(-0.2)	10,4 ^(+0.2) _(-0.2)	10,4 ^(+0.2) _(-0.2)
POWER MAX 100	9 ^(+0.2) _(-0.4)	9 ^(+0.2) _(-0.2)	10,4 ^(+0.2) _(-0.2)	10,4 ^(+0.2) _(-0.2)
POWER MAX 110	9 ^(+0.2) _(-0.4)	9 ^(+0.2) _(-0.2)	10,4 ^(+0.2) _(-0.2)	10,4 ^(+0.2) _(-0.2)
POWER MAX 130	9 ^(+0.2) _(-0.4)	9 ^(+0.2) _(-0.2)	10,4 ^(+0.2) _(-0.2)	10,4 ^(+0.2) _(-0.2)
POWER MAX 150	9 ^(+0.2) _(-0.4)	9 ^(+0.2) _(-0.2)	10,4 ^(+0.2) _(-0.2)	10,4 ^(+0.2) _(-0.2)

Versions POWER MAX 65 P to POWER MAX 80 P

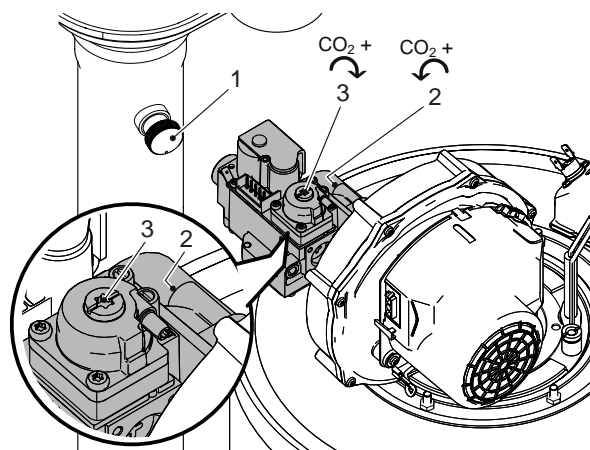

Versions POWER MAX 100 - POWER MAX 150

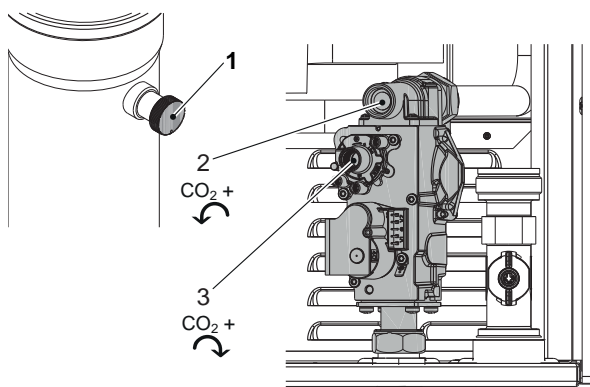

CHECKING THE CALIBRATION

Select "Hi", wait for the stable regime to be reached and make sure that CO values² are the same as the requested ones.

After the checks:

- select "OFF" using "PROG +" and "PROG -" and press "MENU/RESET" to confirm.
- remove the analyser sensor and carefully retighten the cap (1)
- place back the front panel and lock the locking screw.

3.7 Temporary or short-term shut-down

In the event of temporary or short-term shut-down (e.g. due to holidays), proceed as follows:

- Disconnect the power supply by positioning the thermal module switch and the system's main switch to "off".
- If there is a danger of frost, keep the system on. To reduce fuel consumption, set the heating set point to the minimum allowed value.

3.8 Preparing for extended periods of disuse

The following operations shall be necessary if the thermal module is not used for a long period of time:

- turn the main switch of the thermal modules and the main system switch to "off"

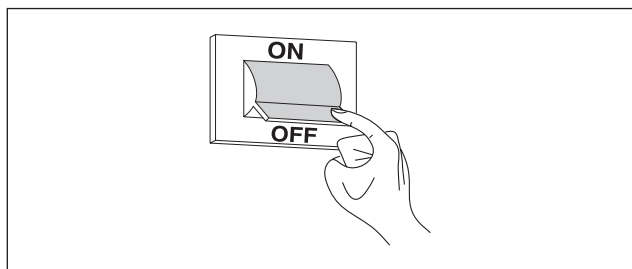

- Close the fuel and water valves for the heating and domestic hot water system.

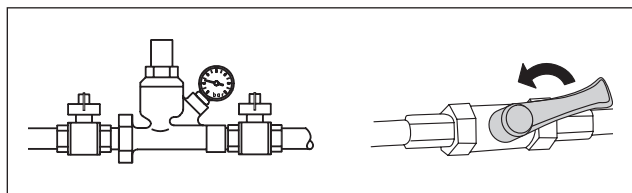

! Empty the thermal and sanitary system if there is a danger of frost.

3.9 Display board replacement

! System configurations must be performed only by the Technical Assistance Centre or by personnel authorized by **Beretta**.

When the front control panel is replaced, at the next restart the system checks the consistency between the configuration data saved on the motherboard and that saved on the user interface; therefore, when replacing the control interface, check Par. 9192, Par. 9098 and Par. 2116.

Change the parameter Par.9192, setting the value according to the following table:

Model	Par. 9097
POWER MAX 65 P	1 (*)
POWER MAX 80 P	1 (*)
POWER MAX 100	1 (*)
POWER MAX 110	1 (*)
POWER MAX 130	1 (*)
POWER MAX 150	1 (*)

! (*) Factory setting. It may be necessary to change the value depending on the type of installation and the accessories installed.

Change the parameter Par.9192, setting the value according to the following table:

Model	Gas	Par. 9098
POWER MAX 65 P	methane	11
	LPG	12
POWER MAX 80 P	methane	9
	LPG	10
POWER MAX 100	methane	7
	LPG	8
POWER MAX 110	methane	5
	LPG	6
POWER MAX 130	methane	3
	LPG	4
POWER MAX 150	methane	1
	LPG	2

Check the settings for parameter 2116:

Model	Par. 2116
POWER MAX 65 P	0
POWER MAX 80 P	0
POWER MAX 100	0
POWER MAX 110	0
POWER MAX 130	0
POWER MAX 150	0

3.10 Control board replacement

 System configurations must be performed only by the Technical Assistance Centre or by personnel authorized by **Beretta**.

When the front control panel is replaced, at the next restart the system checks the consistency between the configuration data saved on the motherboard and that saved on the user interface; therefore, when replacing the control interface, check Par. 9192, Par. 9098 and Par. 2116.

Change the parameter Par.9097, setting the value according to the following table:

Model	Par. 9192 and Par. 9097
POWER MAX 65 P	1 (*)
POWER MAX 80 P	1 (*)
POWER MAX 100	1 (*)
POWER MAX 110	1 (*)
POWER MAX 130	1 (*)
POWER MAX 150	1 (*)

 (*) Factory setting. It may be necessary to change the value depending on the type of installation and the accessories installed.

Change the parameter Par.9192, setting the value according to the following table:

Model	Gas	Par. 9098
POWER MAX 65 P	methane	11
	LPG	12
POWER MAX 80 P	methane	9
	LPG	10
POWER MAX 100	methane	7
	LPG	8
POWER MAX 110	methane	5
	LPG	6
POWER MAX 130	methane	3
	LPG	4
POWER MAX 150	methane	1
	LPG	2

Check the settings for parameter 2116:

Model	Par. 2116
POWER MAX 65 P	0
POWER MAX 80 P	0
POWER MAX 100	0
POWER MAX 110	0
POWER MAX 130	0
POWER MAX 150	0

3.11 Maintenance

It is mandatory to perform maintenance and cleaning of the device at least once a year.

 The non-performance of the annual maintenance will invalidate the warranty.

This operation, carried out by Technical Assistance Centre or by professionally qualified personnel, is necessary to monitor and ensure that the flue pipes inside and outside of the device, the fan, the safety valves, the condensate removal devices, the water drainage tubes and all the measurement and control devices are in perfect working order.

Table of the compulsory maintenance activities (to be performed every 2000 working hours or at least once a year)

Make the combustion test
Check the conditions of the inlet pipes (if present) and the flue pipes by making sure that no leakage is present
Check the ignition electrode
Clean the combustion chamber and check the conditions of the gaskets you have dismantled during such operation
Clean the condensate discharge pipe
Check the parameters settings
Check if there is any gas leakage
Check if there is any leakage on the hydraulic connections
Check the integrity of the cabling system and its related connections
Make sure the ignition takes place regularly
Make sure that there is the flame after ignition
Check the safety devices down the equipment
Check the system pressure

 Before carrying out any maintenance or cleaning, disconnect the power from the device by turning off the bipolar main switch and closing the main gas valve. In addition, for all maintenance (to be carried out at least once a year, as noted above) always replace all the flue and gas seals, in particular the burner seals.

Before performing any operation:

- disconnect the electric power supply by turning the main system switch to "off"
- close the gas shut-off valve.

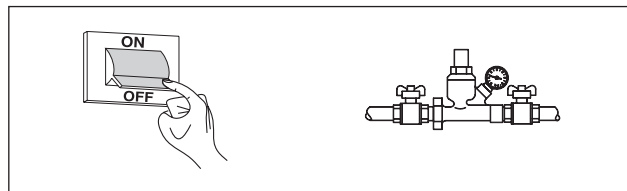

3.12 Cleaning and removing internal components

Before any cleaning operation, disconnect the electric power supply by switching the main system switch to "off".

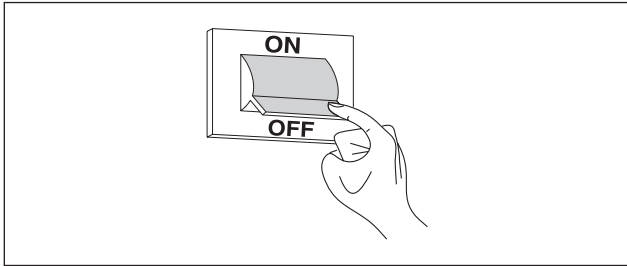

OUTSIDE

Clean the casing, the control panel, the painted parts and plastic parts with cloths moistened with soap and water. In the case of stubborn stains, moisten the cloth with a 50% water and alcohol mixture or specific products.



Do not use fuels, sponges impregnated with abrasive solutions or powder detergents.

INSIDE

Before starting internal cleaning operations:

- close the gas shut-off valves
- close the system taps.

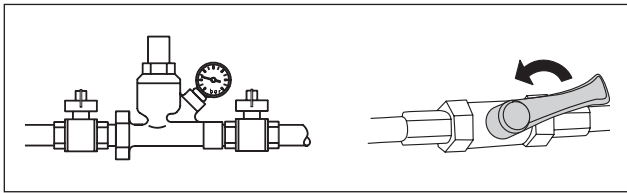

From time to time, check that the condensate drain is not blocked.

Access to the control panel and the internal parts of the thermal module

- Remove the locking screws and the panel's front side
- Pull and slide the electrical panel's box towards the outside (1)

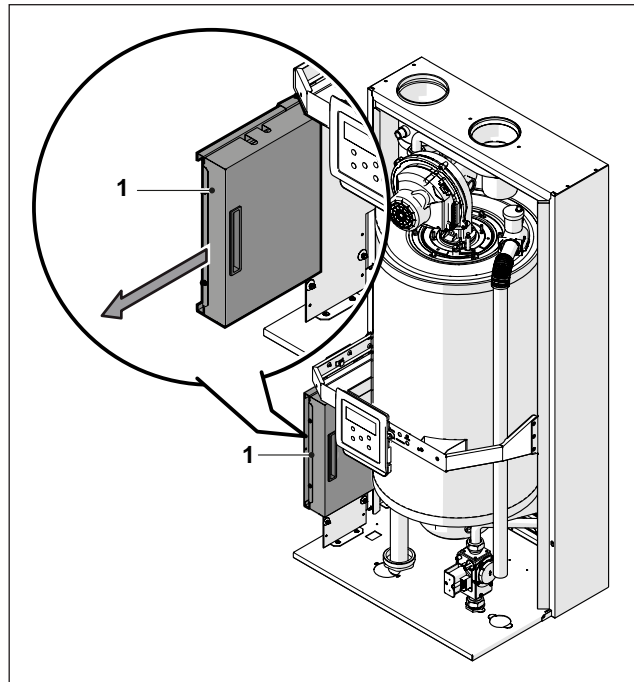

Loosen the fixing screws (2) and remove the protection (3)

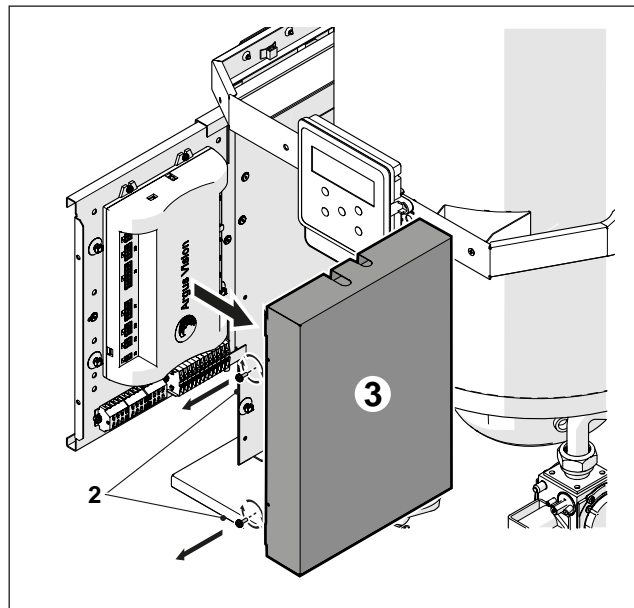

At this point, it will be possible to access terminal boards. Once the maintenance operations are complete, refit the components working in the opposite direction of what was described.



If the electronic control box is replaced, see the electrical wiring diagram in order to reset the connections.

Disassembling of the fan and burners models POWER MAX 65 P - POWER MAX 80 P

- Remove the locking screws and the panel's front side
- Remove cables (1) and (2) for the fan (3)
- Remove the air tube from the fan if the thermal module is of type B - C
- Unscrew the swivel nut (4) and disconnect the gas pipe
- Unscrew the four screws with a pipe wrench (5) fixing the fan (3) to the flange (6)

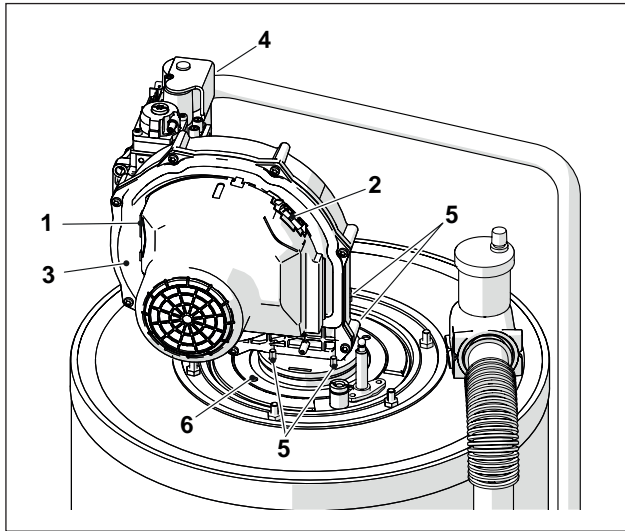

Disassembling of the fan and burners models POWER MAX 100 - POWER MAX 110 - POWER MAX 130 - POWER MAX 150

- Remove the locking screws and the panel's front side
- Remove cables (1) and (2) for the fan (3)
- Remove the air pipe from the fan if the thermal module is type C (C type configuration non standard but obtained with specific accessory)
- Unscrew the swivel nut (4) and disconnect the gas pipe
- Unscrew the four screws with a pipe wrench (5) fixing the fan (3) to the flange (6)

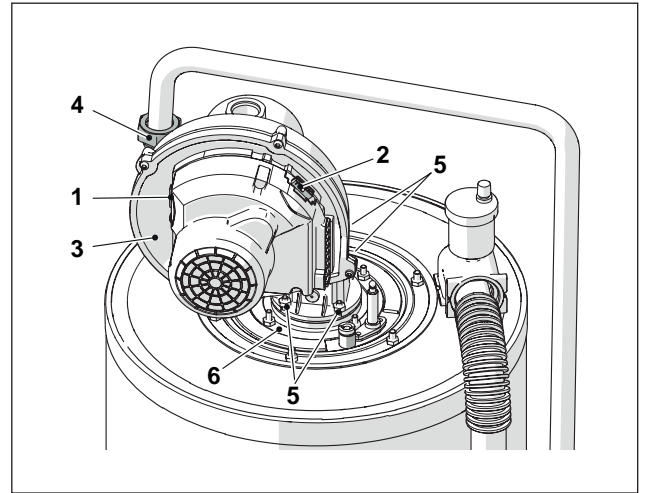

- Take the fan (3) and the gasket (7) out
- Unscrew the 4 screws (8) that fix the flange (6) to the lower flange (9)
- Remove the gasket (10) and the burner (11).

- Take the fan (3) and the gasket (7) out
- Unscrew the 4 screws (8) that fix the flange (6) to the lower flange (9)
- Remove the gasket (10) and the burner (11).

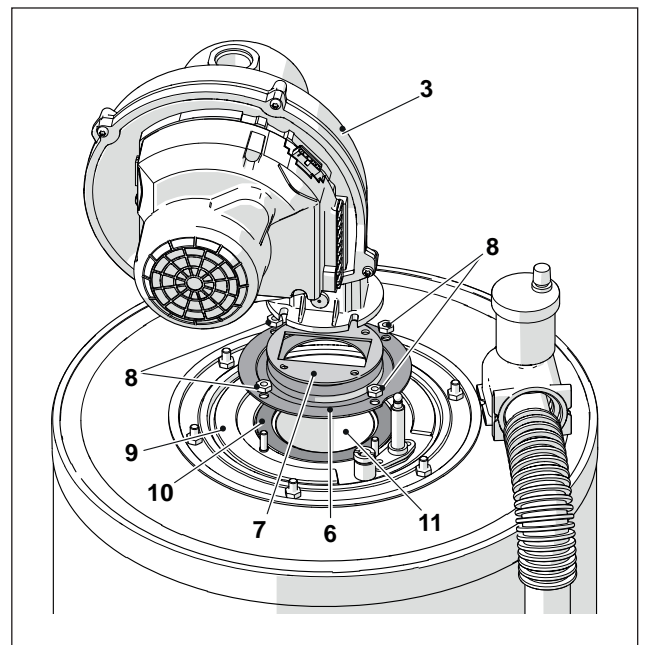
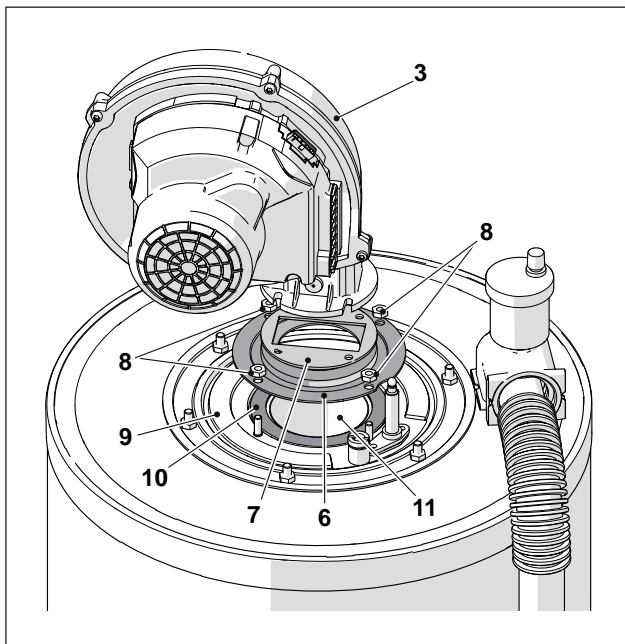

- Replace the gaskets (7-10) with the new ones.
Once the maintenance operations are complete, refit the components working in the opposite direction of what was described, tightening the screws with a torque of 5.

- Replace the gaskets (7-10) with the new ones.
Once the maintenance operations are complete, refit the components working in the opposite direction of what was described, tightening the screws with a torque of 5.

⚠ Check that the gas connection is leak proof.

⚠ Check that the gas connection is leak proof.

disassembling of the flange for cleaning up the heatexchanger models POWER MAX 65 P - POWER MAX 80 P

- Remove the locking screws and the panel's front side
- Remove cables (1) and (2) for the fan (3)
- Remove the air tube from the fan if the thermal module is of type B - C
- Unscrew the swivel nut (4) and disconnect the gas pipe
- Unscrew the six screws (8) that secure the burner unit (9) to the heat exchanger with a socket wrench
- Remove the fan and the entire burner body (9)
- Remove the electrode plate (10), check the electrode's condition and replace it if necessary

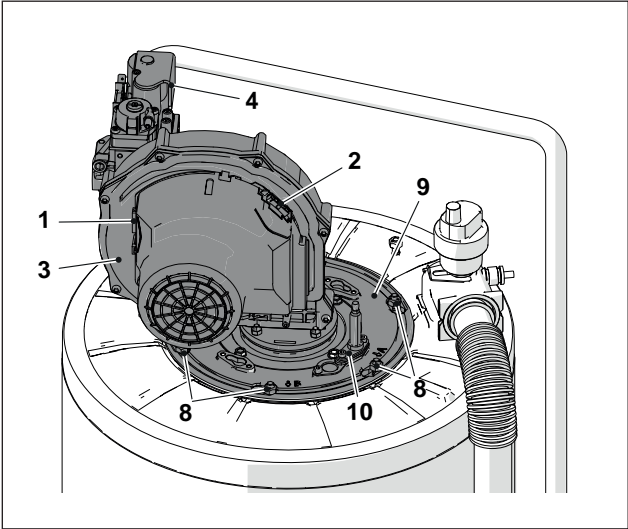

Remove the seal (11), the insulation mat (12) and the bracket (13).

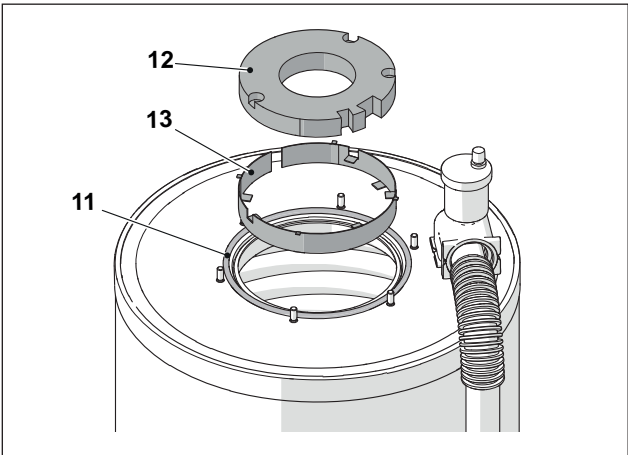

Once the maintenance operations are complete, refit the components working in the opposite direction of what was described, tightening the screws with a torque of 5.

 Check that the gas connection is leak proof.

Disassembling the flange for cleaning the exchanger models POWER MAX 100 - POWER MAX 110 - POWER MAX 130 - POWER MAX 150

- Remove the locking screws and the panel's front side
- Remove cables (1) and (2) for the fan (3)
- Remove the air hose from the fan if the thermal module is of type C (type C configuration not standard but obtained with a special accessory)
- Unscrew the swivel nut (4) and disconnect the gas pipe
- Unscrew the six screws (8) that secure the burner unit (9) to the heat exchanger with a socket wrench
- Remove the fan and the entire burner body (9)
- Remove the electrode plate (10), check the electrode's condition and replace it if necessary

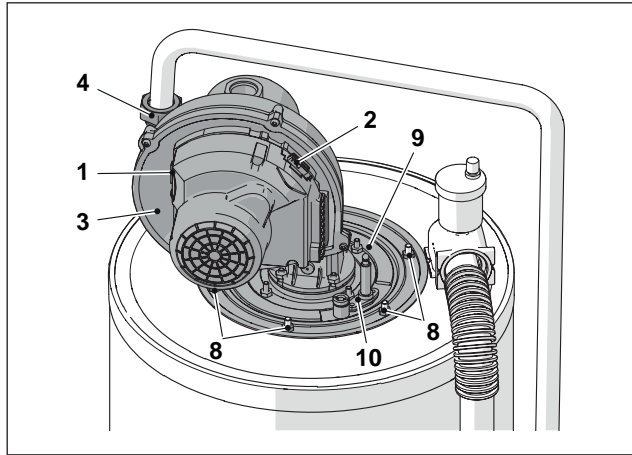

Remove the seal (11), the insulation mat (12) and the bracket (13).

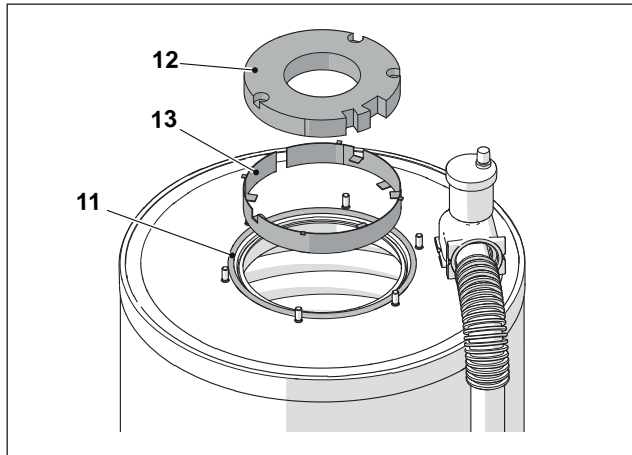

Once the maintenance operations are complete, refit the components working in the opposite direction of what was described, tightening the screws with a torque of 5.

 Check that the gas connection is leak proof.

3.12.1 Condensate drain siphon cleaning

For models POWER MAX 65 P, POWER MAX 80 P, POWER MAX 100, POWER MAX 110, POWER MAX 130, POWER MAX 150 (accessory):

- Locate the condensate drain trap (1), mounted under the appliance.

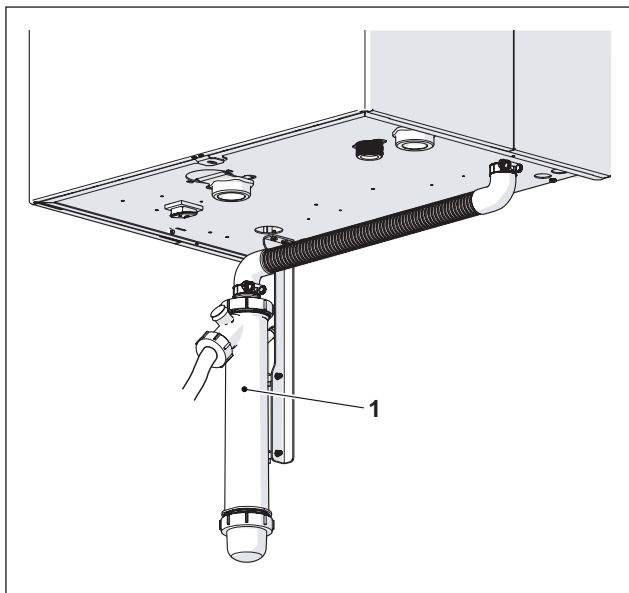

- Loosen the clamp (2), detach the condensate drainage corrugated tube (3), remove the siphon and remove it using the two screw plugs (4)
- Remove the float and clean all internal components.

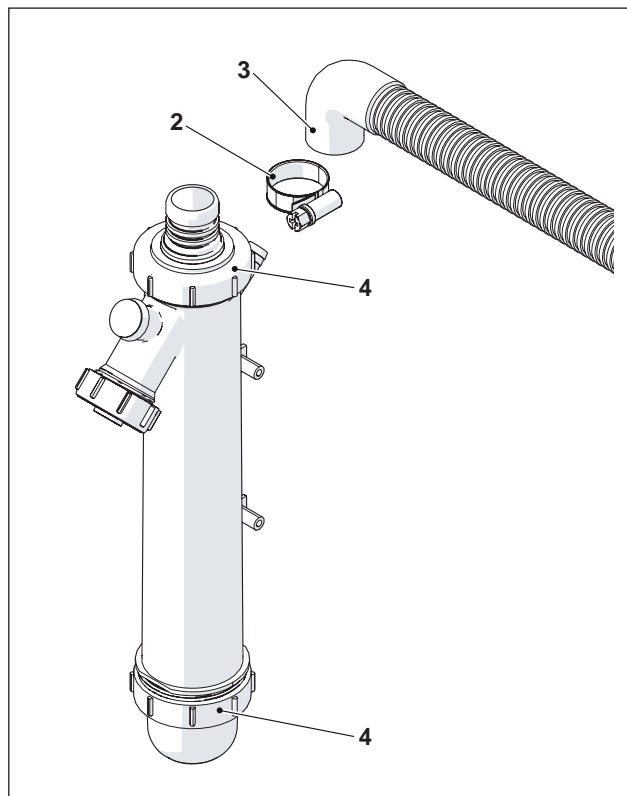

Once the maintenance operations are complete, refit the components working in the opposite direction of what was described.

- ⚠ Fill the siphon with water before you start up the boiler to prevent combustion gases escaping into the room during the first few minutes of boiler functioning.

3.13 Troubleshooting

FAULT	CAUSE	SOLUTION
There is a smell of gas	Gas supply circuit	- Check the seal of the gaskets and the closure of the pressure tapping points
Odour of unburnt gas	Flue gas circuit	- Check the gasket seals - Make sure there are no obstructions - Check the combustion quality
Irregular combustion	Burner gas pressure	- Check the setting
	Diaphragm installed	- Check the diameter
	Clean the burner and exchanger	- Check the conditions
	Exchanger passages obstructed	- Check passage cleaning
	Faulty fan	- Check operation
Ignition delays with pulsations to the burner	Burner gas pressure	- Check the setting
	Ignition electrode	- Check the positioning and conditions
The modular system becomes dirty very quickly	Combustion	- Check the combustion controls
The burner does not start upon consent of the modular system control	Gas valve	- Check for the presence of 230Vac voltage on the gas valve terminals, check wiring and connections
The modular system does not start	No electric power supply (no message on the display)	- Check the electric connections - Check the condition of the fuse
The modular system does not arrive at temperature	Boiler dirty	- Clean the combustion chamber
	Burner capacity insufficient	- Check and adjust the burner
	Modular system adjustment	- Check correct functioning - Check the temperature setting
The generator triggers a thermal safety block	No water	- Check correct functioning - Check the temperature setting - Check the electrical wiring - Check the position of the sensor bulbs
	Modular system adjustment	- Check the bleed valve - Check the heating circuit pressure
The generator is at temperature but the heating system is cold	Presence of air in the system	- Bleed the system
	Pump malfunctioning	- Check/unseize the pump - Replace the circulator - Check the electrical connection of the circulator
The circulator does not start	Pump malfunctioning	- Check/unseize the pump - Replace the circulator - Check the electrical connection of the circulator
Frequent tripping of the system safety valve	System safety valve	- Check calibration or efficiency
	Incorrect circuit pressure	- Check the circuit pressure - Check pressure reducer functioning
	CH expansion vessel	- Check the efficiency of the expansion vessel

4 SYSTEM MANAGER

4.1 Putting into service

 The appliance must be maintained and adjusted at least once a year by Technical Assistance Centre or by professionally qualified staff in compliance with all applicable National and Local provisions.

 Incorrect maintenance or adjustment may damage the appliance and cause damage to people or create a hazard.

 The system manager is forbidden from opening and removing the appliance's casing. These activities must be carried out only by Technical Assistance Centre or by professionally qualified personnel.

The thermal module **POWER MAX Beretta** must be commissioned by Technical Assistance Centre **Beretta**, after which step the appliance may operate automatically.

However, the system manager may be required to restart the appliance independently, without involving Technical Assistance Centre; for example after a long period of absence.

To do so, perform the following checks and operations:

- Check that the gas cock and heating water cock are open

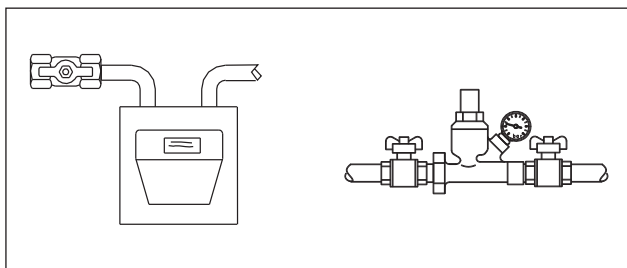

- While the system is still cold, check that working pressure in the central heating circuit is over 1 bar but below the maximum limit specified for the boiler

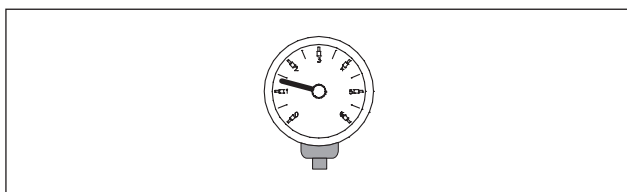

- Adjust the room thermostats for the high and low temperature zones to the required temperature (~20°C) or, if the systems are equipped with timer thermostats or a time programming unit, make sure it is on and adjusted (~20°C)

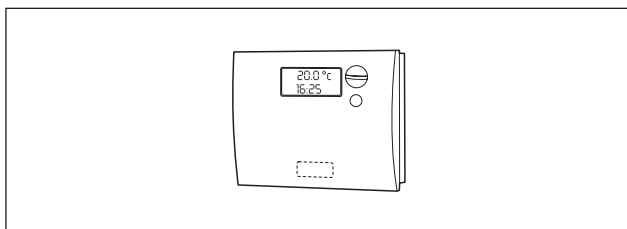

- Switch the system's master switch to the ON position and the thermal module's master switch to (I).

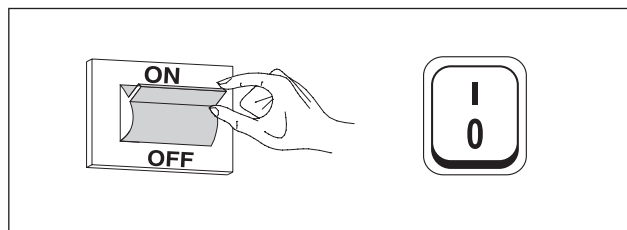

The appliance will go through the switch-on stage and, after starting, it will continue to operate until set temperatures are achieved.

The burner will then switch off and on automatically to maintain the set temperature without further operator action.

In the event of ignition or operation faults, the display will show a numeric error code that will enable the user to interpret the possible cause as detailed in Paragraph "Error List".

-  In the event of a permanent error, to reset starting conditions press the "RESET" key and wait for the thermal module to restart.

Repeat this operation 2-3 times at the most. If the problem persists after that, call **Beretta's** Technical Assistance Centre.

4.2 Temporary or short-term shut-down

In the event of temporary or short-term shut-down (e.g. due to holidays), proceed as follows:

- Disconnect the power supply by positioning the thermal module switch and the system's main switch to "off".
- If there is a danger of frost, keep the system on. To reduce fuel consumption, set the heating set point to the minimum allowed value.

4.3 Preparing for extended periods of disuse

The following operations shall be necessary if the thermal module is not used for a long period of time:

- turn the main switch of the thermal modules and the main system switch to "off"

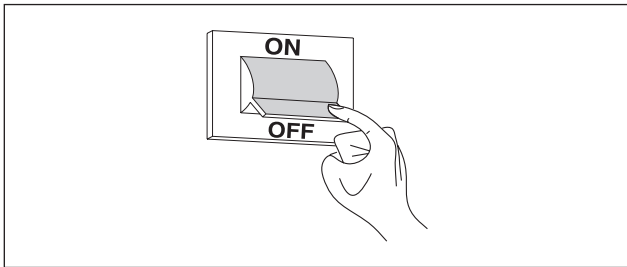

- Close the fuel and water valves for the heating and domestic hot water system.

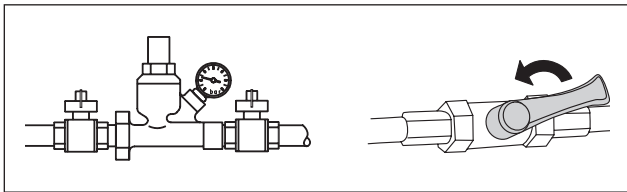

- ⚠ Empty the thermal and sanitary system if there is a danger of frost.

4.4 Cleaning

Use a cloth dampened in soapy water to clean the boiler's external casing.

To remove stubborn marks, use a cloth dampened in a 50% mix of water and denatured alcohol or a suitable cleaning product.

Carefully dry after cleaning.



Do not use abrasive cleaning pads or powder detergents.



Never clean the boiler without first disconnecting it from the mains electricity supply by turning the mains power switch and the control panel switch OFF.



The combustion chamber and flue pipes must be cleaned periodically by the manufacturer's Technical Assistance Centre or by a qualified heating engineer.

4.5 Maintenance

Please remember that THE PERSON RESPONSIBLE FOR SYSTEM MANAGEMENT MUST ENSURE THAT PROFESSIONALLY QUALIFIED HEATING ENGINEERS UNDERTAKE PERIODIC MAINTENANCE AND COMBUSTION EFFICIENCY MEASUREMENTS.

Beretta's Technical Assistance Centre is qualified to satisfy these legal requirements and can also provide useful information on MAINTENANCE PROGRAMMES designed to guarantee:

- Greater safety
- Compliance with applicable legislation
- Freedom from the risk of fines in the event of spot checks.

Regular maintenance is essential for the safety, efficiency and durability of the boiler.

Servicing is a legal requirement and must be performed at least once a year by a professionally qualified heating engineer.

5 RECYCLING AND DISPOSAL

The appliance is manufactured using various materials, such as metal, plastics, and electric and electronic components. At the end of the life cycle, safely remove the components and dispose of them in a responsible manner, in compliance with the installation country's applicable environmental legislation.

 Adequate sorted waste collection, processing and environmentally-friendly disposal contribute to preventing possible negative impacts on the environment and health and promote the reuse and/or recycling of the materials of which the appliance consists.

 Illegal disposal of the product by the owner shall be subject to administrative fines provided for by applicable laws.

Via Risorgimento, 23 A
23900 - Lecco (LC)

www.berettaboilers.com

The manufacturer strives to continuously improve all products. Appearance, dimensions, technical specifications, standard equipment and accessories are therefore liable to modification without notice.

