

POWER EVO-X

Condensing | High power boiler

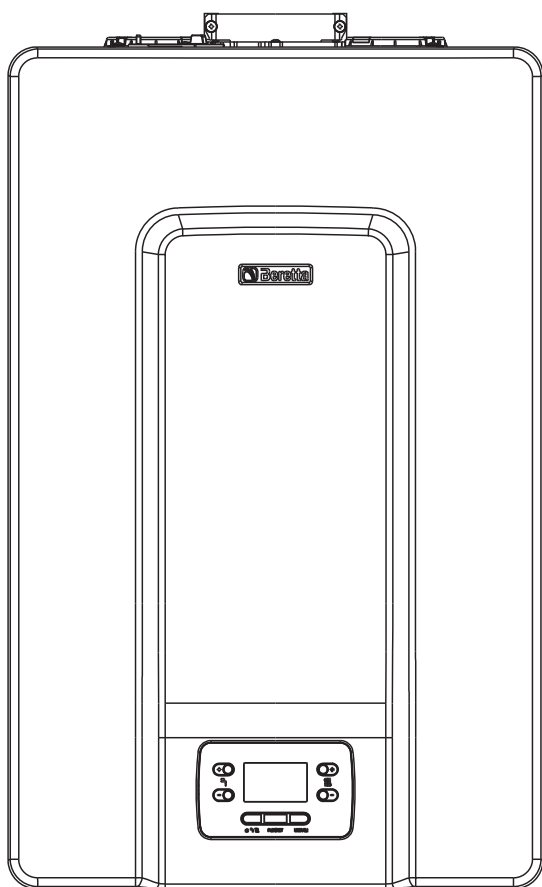

POWER EVO-X 50 DEP - 50

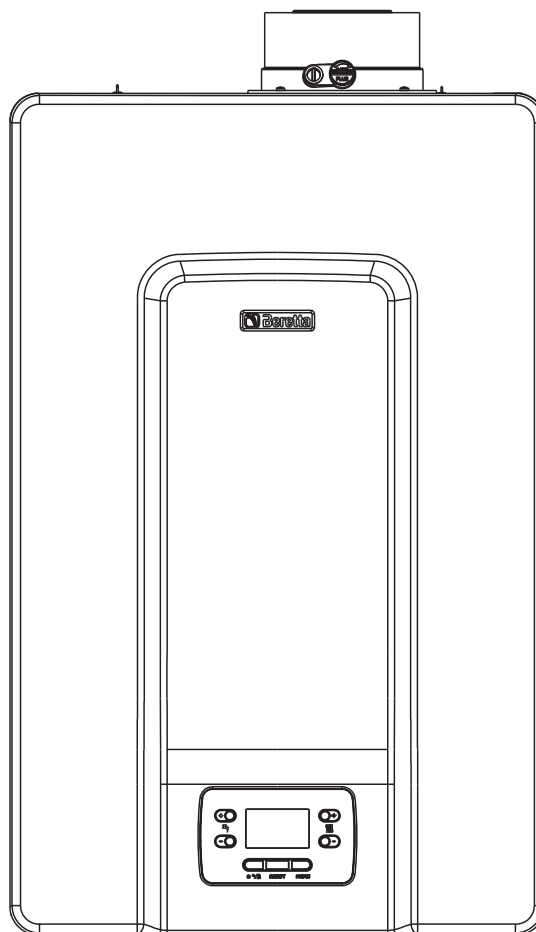

POWER EVO-X 65 - 80

POWER EVO-X boilers comply with:

- Regulation (EU) 2016/426
- Efficiency directive: Article 7(2) and Annex III of directive 92/42/EEC
- Electromagnetic Compatibility Directive 2014/30/EU
- Low Voltage Directive 2014/35/EU
- Ecodesign Requirements for Energy-Related Products Directive 2009/125/EC
- Regulation (EU) 2017/1369 Energy Labelling
- Delegated Regulation (EU) No. 811/2013
- Delegated Regulation (EU) No. 813/2013
- Boiler standards for gas heating – General requisites and EN 15502-1 tests
- Specific regulations for type C appliances and type B2, B3 and B5 appliances with a rated heat output no larger than 1000 kW EN 15502-2/1
- SSIGA Gas Appliance Directive G1
- AICAA Fire prevention requirements
- CFST LPG Directive Part 2
- MISCELLANEOUS cantonal and municipal regulations regarding air quality and energy savings.



WARNING











This instructions manual contains data and information for both the user and the installer. Specifically, note that the user, for the use of the appliance, must refer to chapters: Warnings and safety • Control panel • Commissioning • Maintenance.

The user must not perform operations on the safety devices, replacing parts of the product, tamper with or attempt to repair the appliance. These operations must be entrusted exclusively professionally qualified personnel.















The manufacturer is not liable for any damage caused by the non-observance of the above and/or the failure to comply with the regulations.





Register the product: scan the QR code or go to “www.myeasycomfort.com”

1	WARNINGS AND SAFETY 	4
1.1	Boiler description	5
1.2	Safety devices	5
1.3	Structure	6
1.4	Technical data	7
1.5	Circulator residual discharge head	12
1.6	Variable speed circulator	12
1.7	Manual circulator reset	12
1.8	Water circuit	13
1.9	Control panel	14
1.10	Structure menu	15
1.11	Description of the parameters	17
1.12	Configuring a system with REC10	19
1.13	Boiler cascade configuration	20
1.14	Accessing the parameters	20
2	INSTALLATION	21
2.1	Consignment of the appliance	21
2.2	Dimensions and weights	21
2.3	Installation room	21
2.4	Minimum clearance areas recommended	22
2.5	Instructions for the condensate discharge connection	22
2.6	Condensate neutralisation	22
2.7	Installation on appliances that are old or that need to be updated	22
2.8	Assembling the boiler	23
2.9	Schematic hydraulic systems	25
2.10	Removing the casing	28
2.11	Gas connections	28
2.12	Electrical wiring	28
2.13	Flue gas exhaust and combustion air suction	32
2.14	Filling the heating system and eliminating air	35
2.15	Emptying the heating system	35
3	COMMISSIONING	36
3.1	Preliminary checks	36
3.2	Programming the boiler	36
3.3	Setting the temperature control	37
3.4	Auto season change Winter - Summer 	38
3.5	Initial start-up 	38
3.6	Operating status 	38
3.7	Adjusting the heating water temperature without an outdoor temperature sensor connected (only in the case of a boiler with sensor) 	38
3.8	Adjusting the heating water temperature with an outdoor temperature sensor connected 	39
3.9	Adjusting the domestic hot water temperature 	39
3.10	Safety stop 	39
3.11	Reset function 	39
3.12	Screed heater function	39
3.13	Sliding delivery (only if a storage tank is connected)	40
3.14	Anti-legionella function (only if a storage tank with probe is connected) 	40
3.15	Special function: simultaneous DHW and HEATING (P5.14)	40
3.16	Checks during and after the first commissioning	40
3.17	Combustion check	40
3.18	Adjustments	41
3.19	Gas valve calibration	41
3.20	Gas conversion	42
3.21	Signalling and faults 	42
3.22	INFO menu 	44
3.23	Temporary switch-off 	44
3.24	Switching off for lengthy periods 	44
3.25	Keypad lock function 	45
3.26	Alarm log 	45
3.27	Interface standby	45
3.28	Replacing the interface	45
3.29	Replacing the board	45
4	MAINTENANCE AND CLEANING	46
4.1	Disassembling the internal components	48

1 WARNINGS AND SAFETY

-  The boilers produced in our plants are built paying special attention to the individual components, to safeguard both the installer and the user from any risk of accidents. After work has been carried out on the appliance, qualified personnel must check the electrical wiring, in particular the stripped part of wires, which must not protrude at all from the terminal board as this may lead to contact with the live parts of the wire itself.
-  This installer and user manual constitutes an integral part of the product: make sure they are always kept with the appliance, even if it is transferred to another owner or user, or moved to another heating system. In the event of loss or damage, please contact your local Technical Assistance Centre for a new copy.
-  The boiler must only be installed and serviced by qualified personnel, in accordance with current regulations and UNI 7129-7131, and as amended.
-  The appliance must be installed by a qualified company that provides the owner with a declaration of installation conformity at the end of the work, confirming that the installation has been carried out to the highest standard in accordance with the national and local regulations in force and with the indications given by the manufacturer in the instruction booklet supplied with the appliance.
-  The appliance must be used for the functions for which it was purposely designed, as intended by the manufacturer. No contractual or extra-contractual liability can be accepted by the manufacturer for harm to people or animals, or damage to property, due to installation, adjustment or maintenance errors or improper use.
-  The installer must instruct the user about how the appliance works, and the essential safety rules.
-  The user must respect the warnings given in this manual.
-  This appliance may be used by children over the age of 8, people with reduced physical, sensory or mental capacities, and inexperienced people who are not familiar with the product, as long as they are supervised or have been instructed on how to use it safely and are made aware of the dangers that may be involved. Children must not play with the appliance. It is the user's responsibility to clean and maintain the appliance. Children should never clean or maintain it unless they are given supervision.
-  After removing the packaging, make sure the content is in good condition and complete. Otherwise, contact the dealer from whom you purchased the appliance.
-  In the event of a water leakage, disconnect the boiler from the main power supply, shut off the water supply, and promptly notify the Aftersales Service or professionally qualified personnel.
-  The seal of the condensate drainage connection line must be secure, and the line must be fully protected against the risk of freezing (e.g. by insulating it).
-  Check that the rainwater drainage channel of the flue gas exhaust coupling and the relative connecting pipe are free of obstructions.
-  Dispose of all the packaging materials in the suitable containers at the corresponding collection centres.
-  When disposing of waste, be careful not to harm human health or employ procedures or methods which may damage the environment.













-  During installation, it is important to inform the user that:
 - in the event of water leakages, the water supply must be shut off and the Aftersales Service must be contacted immediately
 - the operating pressure of the hydraulic system must be checked regularly to make sure it is between 1.5 and 2.0 bar; if this is not the case, contact the Aftersales Service or professionally qualified personnel

-  If the boiler is not used for a long time, you are advised to carry out the following operations:
 - set the boiler status to 
 - Set the system's main switch to "off"
 - turn off the fuel and water taps of the heating system
 - drain the heating and domestic hot water circuits if there is any risk of them freezing

-  Boiler maintenance must be carried out at least once a year, booking it in advance with the Aftersales Service. As defined in local regulations, the qualified engineer must establish the requirements and frequency of the checks and any system maintenance needed to guarantee the required safety. If this information is not provided, refer to the manufacturer's indications.

-  At the end of its working life, the product must not be disposed of as solid urban waste; it must be handed over to a differentiated waste collection centre.

Remember that the use of products requiring fuels, electricity and water calls for the respect of certain basic safety rules such as:

-  It is forbidden to access the inner parts of the boiler. Any work on the boiler must be carried out by the Aftersales Service or by professionally qualified personnel.
-  It is forbidden to activate electric devices or appliances such as switches, household appliances and so on if you notice a smell of fuel or unburnt fuel. In this case:
 - air the room by opening the doors and windows;
 - close the fuel shut-off device;
 - ask the Technical Assistance Service or professionally qualified personnel to intervene promptly.
-  It is forbidden to touch the appliance while barefoot or if parts of your body are wet.
-  It is forbidden to carry out any technical or cleaning task without first disconnecting the appliance from the main power supply by turning the main system switch to "OFF" and setting the boiler status at .
-  Do not modify the safety or adjustment devices without the manufacturer's authorisation and precise instructions.
-  It is prohibited to pull, detach or twist the electrical cables coming from the appliance even if it is disconnected from the mains power supply.
-  Avoid blocking or reducing the size of the air vent openings in the installation room.
-  Do not leave flammable containers and substances in the room where the device is installed.
-  Dispose of the packaging material responsibly. Do not leave it within children's reach, as it may be a potential source of danger. It must be disposed in accordance with the present law.
-  It is forbidden to obstruct the condensate drain outlet. The condensate drain pipe should be facing the discharge pipe, preventing the formation of further drain pipes.
-  It is forbidden to intervene in any way on the gas valve.
-  It is forbidden to intervene on sealed elements.

The following symbols are used in some parts of this booklet:

 Section destined for user also.

 **WARNING** = for actions requiring special caution and adequate preparation.

 **PROHIBITION** = for actions that MUST NEVER be carried out under any circumstances.

The parts relating to the DHW function should only be considered if there is a connection to a remote-controlled storage tank (accessory available upon request) and the hydraulic configuration parameter P3.01 = 3 - STORAGE TANK WITH PROBE or = 4 - STORAGE TANK WITH THERMOSTAT.

1.1 Boiler description

POWER EVO-X is a type C wall-hung condensing boiler that can operate as follows:

CASE A: heating only, without any external storage tank connected. The boiler does not supply domestic hot water.

CASE B: heating only, with a thermostatically-controlled external storage tank (accessory kit available upon request) connected: in this condition, with every heat request from the storage tank thermostat, the boiler supplies hot water for the preparation of the domestic hot water.

CASE C: heating only, with the connection of an external storage tank (accessory kit available upon request) managed by a temperature probe, for domestic hot water preparation. Connecting a boiler that we did not supply, make sure that the probe used has the following characteristics: 10 kOhm at 25°C, B 3435 ±1%.

Depending on the flue gas exhaust accessory used, the boiler is classified in categories B23P; B53P; C13,C13x; C33,C33x; C43,C43x; C53,C53x; C63,C63x; C83,C83x; C93,C93x.

In configuration B23P (when installed indoors), the appliance cannot be installed in bedrooms, bathrooms, showers or where there are open fireplaces without a proper air flow. The room where the boiler is installed must have proper ventilation. Detailed requirements for the installation of the flue, the gas piping and for ventilating the room, can be found in UNI 7129-7131.

This type of appliance can be installed indoors, within a suitable room (central heating), as well as outdoors, in a partially protected location (single boiler application).

Furthermore, with the aid of specific accessories, the boiler can be installed in cascade configuration (up to 4 in-line boilers), or front-and-back configuration (up to 4 boilers - 2+2).

⚠ WARNING: it is impossible to create modular generators simultaneously containing thermal elements with different heat input values. Only cascades, with the same thermal element version on all the thermal modules, can be created.

1.2 Safety devices

All the appliance functions are electronically controlled by a board that has been type-approved for safety functions.

Any malfunction results in the appliance being shut down and the automatic closure of the gas valve.

The following are installed on the water circuit:

- Temperature probes on the delivery and return lines, to continuously measure the temperature difference (Δt) between input and output fluid, and allow the control to intervene.
- Pressure transducer with a minimum pressure function, to inhibit burner ignition below 0.8 bar.

The following are installed on the combustion circuit:

- Ignition electrode and detection electrode
 - Flue gas temperature probe
 - Safety thermostat
 - Gas valve
- The intervention of the safety devices indicates a potentially hazardous boiler malfunction, therefore immediately contact the Technical Assistance Service immediately. After a brief pause, it is possible to try to restart the appliance (see "3.1 Preliminary checks").

⚠ Safety devices must be replaced by the Technical Assistance Centre, using only original parts. Refer to the spare parts catalogue. After carrying out repairs, check that the appliance is working properly.

⊖ The appliance must not be started, not even temporarily, when safety devices are not working or have been tampered with.

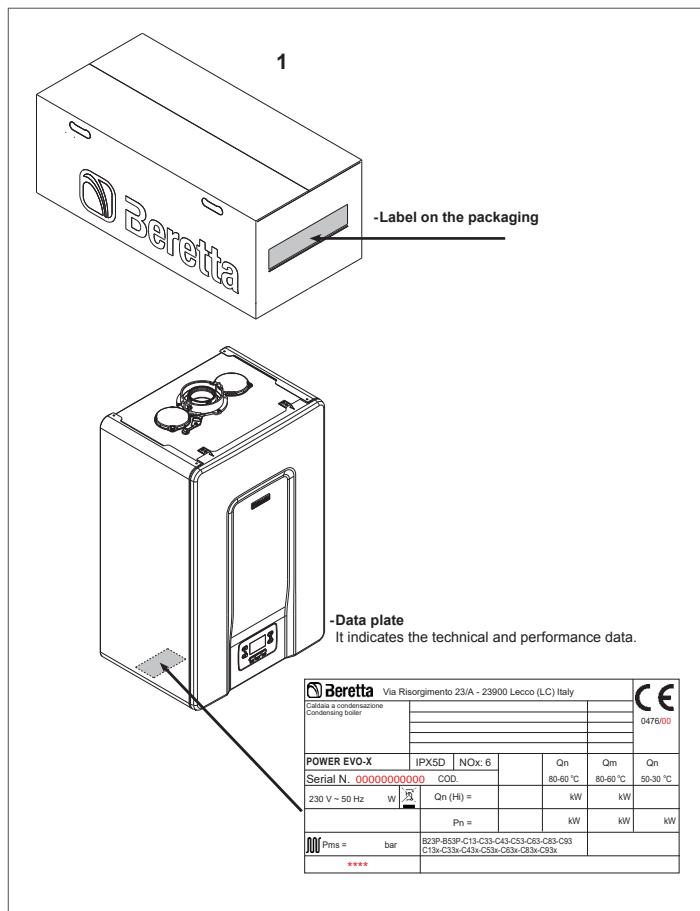

⚠ Tampering, removal, lack of identification labels or anything else which does not permit the safe identification of the product, makes any installation and maintenance operation difficult.

Qn	Rated heat input (heating)
Qm	Reduced heat input (heating)
Qn (Hi)	Rated heat input (lower calorific value)
Pn	Nominal heat output
 Pms	Operation heating maximum pressure
T	Temperature
IP	Protection level
NOx	NOx class

1.3 Structure

POWER EVO-X 50 DEP - 50

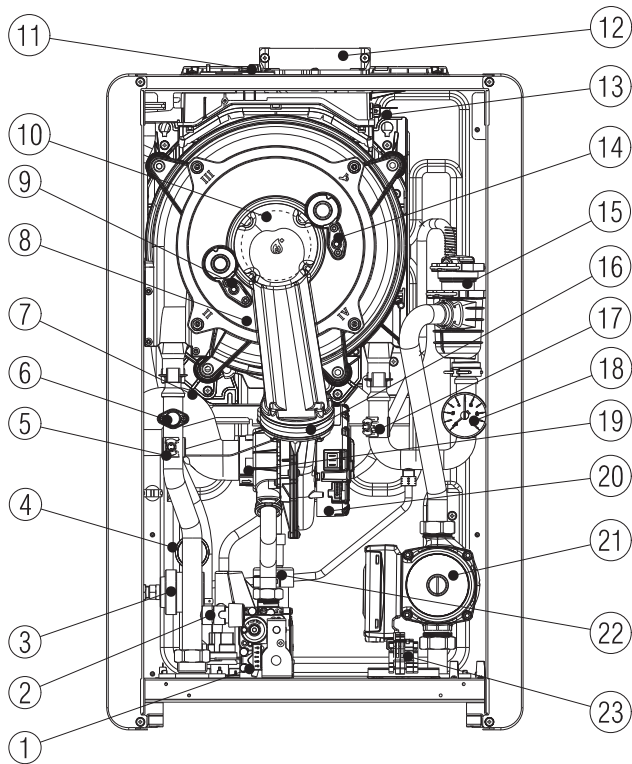

- 1 Gas valve
- 2 Degassing unit/boiler discharge tap
- 3 Differential heating pressure switch
- 4 Pressure transducer with minimum pressure function
- 5 NTC delivery probe
- 6 Safety thermostat with manual reset by means of a board reset
- 7 Suction line
- 8 Heat exchanger
- 9 Detection electrode
- 10 Burner
- 11 Flue gas analysis outlet
- 12 Flue gas exhaust
- 13 Flue gas probe
- 14 Ignition electrode
- 15 Air vent valve
- 16 Check valve
- 17 NTC return line probe
- 18 Pressure gauge
- 19 Mixer
- 20 Fan
- 21 Circulator
- 22 Drain-trap
- 23 Power supply connector

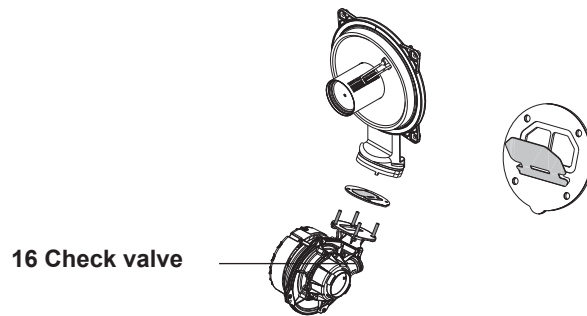

16 Check valve

POWER EVO-X 65 - 80

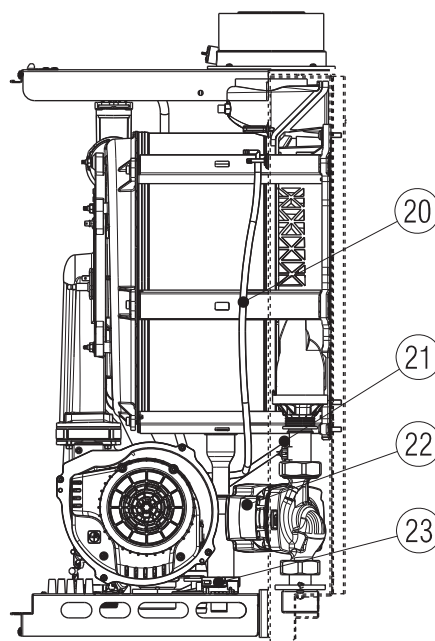
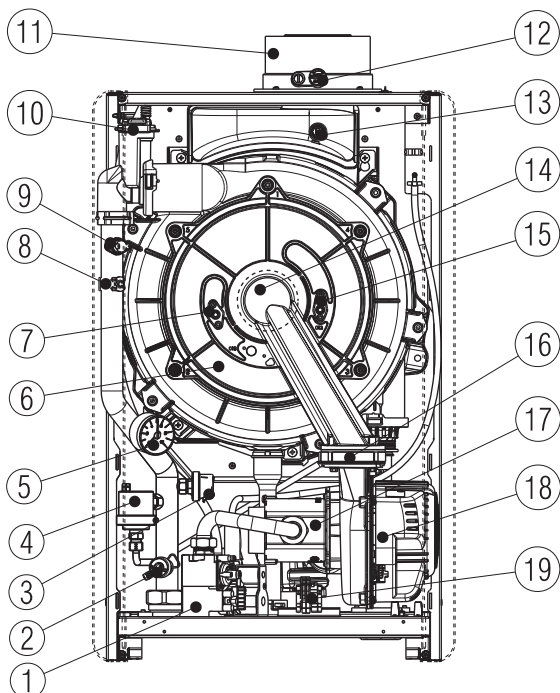

- 1 Gas valve
- 2 Degassing unit/boiler discharge tap
- 3 Pressure transducer with minimum pressure function
- 4 Heating pressure switch
- 5 Pressure gauge
- 6 Heat exchanger
- 7 Detection electrode
- 8 NTC delivery probe
- 9 Safety thermostat with manual reset by means of a board reset
- 10 Air vent valve
- 11 Flue gas exhaust
- 12 Flue gas analysis outlet
- 13 Flue gas probe
- 14 Burner
- 15 Ignition electrode
- 16 Check valve
- 17 Mixer
- 18 Fan
- 19 Power supply wiring
- 20 Atmospheric silicon tube
- 21 NTC return line probe
- 22 Circulator
- 23 Drain-trap

1.4 Technical data

DESCRIPTION		UM	POWER EVO-X							
			50 DEP		50		65		80	
			G20	G31	G20	G31	G20	G31	G20	G31
Heating	Rated heat input	kW	34,90		45,00		55,00		70,00	
		kcal/h	30.014		38.700		47.300		60.200	
	Nominal heat output (80°/60°)	kW	33,99		43,88		53,60		68,24	
		kcal/h	29.234		37.733		46.099		58.683	
	Nominal heat output (50°/30°)	kW	37,31		47,30		58,25		74,19	
		kcal/h	32.085		40.674		50.095		63.806	
	Reduced heat input	kW	5,20	-	5,20	-	8,20	-	8,20	-
		kcal/h	4.472	-	4.472	-	7.052	-	7.052	-
	Reduced heat output (80°/60°)	kW	4,98	-	4,98	-	7,87	-	7,87	-
		kcal/h	4.284	-	4.284	-	6.767	-	6.767	-
Reduced heat output (50°/30°)	kW	5,57	-	5,57	-	8,78	-	8,78	-	
	kcal/h	4.794	-	4.794	-	7.547	-	7.547	-	
DHW	Rated heat input	kW	34,90		45,00		55,00		70,00	
		kcal/h	30.014		38.700		47.300		60.200	
	Nominal heat output (*)	kW	34,90		45,00		55,00		70,00	
		kcal/h	30.014		38.700		47.300		60.200	
	Reduced heat input	kW	5,20	-	5,20	-	8,20	-	8,20	-
		kcal/h	4.472	-	4.472	-	7.052	-	7.052	-
	Reduced heat output (*)	kW	5,20	-	5,20	-	8,20	-	8,20	-
		kcal/h	4.472	-	4.472	-	7.052	-	7.052	-
	Useful efficiency Pn max - Pn min (80°/60°)	%	97,4 - 95,8		97,5 - 95,8		97,5-96,0		97,5-96,0	
	Combustion efficiency	%	97,6		97,7		97,6		97,6	
Useful efficiency Pn max - Pn min (50°/30°)	%	106,9 - 107,2		105,1-107,2		105,9-107,0		106,0-107,0		
Useful efficiency 30% Pn max (30° return)	%	108,2		107,9		107,6		107,5		
Overall electric power (maximum heating output)	W	158		175		201		284		
Circulator electric power (1,000 l/h)	W	98		98		88		88		
Category • Country of destination		II2HY203P • (+)		II2HY203P • (+)		II2HY203P • (+)		II2HY203P • (+)		
Voltage supply	V-Hz	230-50		230-50		230-50		230-50		
Protection level	IP	X5D		X5D		X5D		X5D		
Stop loss	W	37,0		35,0		35,0		35,0		
Losses at the flue with burner off - burner on	%	0,06 - 2,38		0,05 - 2,35		0,04 - 2,41		0,03-2,44		
Heating operation										
Maximum pressure	bar	5		5		5		5		
Minimum pressure for standard operation	bar	0,8 ÷ 1,0		0,8 ÷ 1,0		0,8 ÷ 1,0		0,8 ÷ 1,0		
Safety thermostat intervention	°C	102 (±3)		102 (±3)		102 (±3)		102 (±3)		
Maximum temperature	°C	90		90		90		90		
Selection field of heating water temperature	°C	20 ÷ 90/20 ÷ 45		20 ÷ 90/20 ÷ 45		20 ÷ 90/20 ÷ 45		20 ÷ 90/20 ÷ 45		
Pump: maximum head available for the system	mbar	820		820		430		430		
at a flow rate of	l/h	1.000		1.000		2.500		2.500		
Heating circuit water content	l	4,75		4,75		9,00		9,00		

(+) The installation of this product is allowed only in the destination Countries contained in the data plate, regardless of the present translation language.

 In case of connection to a domestic hot water exchanger kit (accessory available on request) consider an additional 6.5 liters of water with respect to the heating circuit water content.

DESCRIPTION	UM	POWER EVO-X								
		50 DEP		50		65		80		
Gas pressure		G20	G31	G20	G31	G20	G31	G20	G31	
Nominal natural gas pressure (G20 - I2H)	mbar	20	-	20	-	20	-	20	-	
Nominal pressure natural gas-H (G20Y20 - I2HY20)	mbar	20	-	20	-	20	-	20	-	
Nominal liquid gas pressure - LPG (G31 - I3P)	mbar	-	37	-	37	-	37	-	37	
Heating input - output	Ø	1" 1/2 M		1" 1/2 M		1" 1/2 M		1" 1/2 M		
Gas input	Ø	3/4"		3/4"		3/4"		3/4"		
Storage tank inlet - outlet (optional)	Ø	1" 1/2 M		1" 1/2 M		1" 1/2 M		1" 1/2 M		
Heating output		G20	G31	G20	G31	G20	G31	G20	G31	
Air flow rate	Nm³/h	42,399	43,309	54,670	55,843	66,819	68,252	85,042	86,866	
Flue gas flow rate	Nm³/h	45,900	46,016	59,184	59,333	72,336	72,518	92,064	92,295	
Mass flue gas flow rate (max-min)	g/s	15,855- 2,362	16,223- 2,417	20,443- 2,362	20,918- 2,417	24,986- 3,725	25,567- 3,812	31,800- 3,725	32,540- 3,812	
DHW output		G20	G31	G20	G31	G20	G31	G20	G31	
Air flow rate	Nm³/h	42,399	43,309	54,670	55,843	66,819	68,252	85,042	86,866	
Flue gas flow rate	Nm³/h	45,900	46,016	59,184	59,333	72,336	72,518	92,064	92,295	
Mass flue gas flow rate (max-min)	g/s	15,855- 2,362	16,223- 2,417	20,443- 2,362	20,918- 2,417	24,986- 3,725	25,567- 3,812	31,800- 3,725	32,540- 3,812	
Fan performance										
Residual discharge head of concentric pipes 0.85 m	Pa	60		60		-		-		
Residual discharge head of separate pipes 0.5 m	Pa	160		192		172		197		
Residual discharge head of boiler without pipes	Pa	166		198		180		200		
Concentric flue gas exhaust pipes										
Diameter	mm	60-100		60-100		60-100		60-100		
Maximum length	m	10		10		-		-		
Loss for insertion of a 45°/90° bend	m	1,3/1,6		1,3/1,6		1,3/1,6		1,3/1,6		
Hole in wall (diameter)	mm	105		105		105		105		
Diameter	mm	80-125		80-125		80-125		80-125		
Maximum length	m	25		25		10		10		
Loss for insertion of a 45°/90° bend	m	1/1,5		1/1,5		1/1,5		1/1,5		
Hole in wall (diameter)	mm	130		130		130		130		
Separate flue gas exhaust pipes										
Diameter	mm	80		80		80		80		
Maximum length	m	30+30		21+21		12+12		10+10		
Loss for insertion of a 45°/90° bend	m	1/1,5		1/1,5		1/1,5		1/1,5		
Forced open installation B23P-B53P										
Diameter	mm	80		80		80		80		
Maximum discharge tube length	m	48		33		17		13		
NOx class		6		6		6		6		
Emission values at maximum and minimum output (**)		G20	G31	G20	G31	G20	G31	G20	G31	
Maximum	CO s.a. lower than	p.p.m.	120	130	150	160	170	170	220	230
	CO2	%	9,0	10,0	9,0	10,0	9,0	10,0	9,0	10,0
	NOx s.a. lower than	p.p.m.	50	50	60	60	50	50	60	60
Minimum	Flue gas temperature	°C	68	66	71	73	66	70	70	76
	CO s.a. lower than	p.p.m.	30	30	30	30	40	20	40	20
	CO2	%	9,0	10,0	9,0	10,0	9,0	10,0	9,0	10,0
	NOx s.a. lower than	p.p.m.	40	45	40	45	40	60	40	60
	Flue gas temperature	°C	60	58	60	58	57	58	57	58

(*) Average value of various hot water operating conditions

(**) Check made with concentric pipe Ø60-100 (POWER EVO-X 50 DEP-50) and Ø80-125 (POWER EVO-X 65-80), length 0.85 m - in heating, water temperature 80-60°C - values measured with the casing completely closed

The data indicated must not be used to certify the system; for certification, use the data indicated in the "System handbook" measured during first ignition.

Description	POWER EVO-X boiler type											
	50 DEP	50	65	80	50 DEP	50	65	80	50 DEP	50	65	80
	C4				C6				C8			
Temperature of the flue gases in nominal conditions (at 80/60°C) - [°C]	58	59,8	48,8	56,9	72,2	75,5	68,8	76,0	55,3	56,7	45,9	54,4
Mass flow rate [m³/h] @ nominal output [kW]	3,77	4,864	5,989	7,702	3,816	4,849	5,799	7,486	3,929	4,976	5,93	7,759
Nominal output [kW]	35,4	45,47	57,11	73,51	35,78	45,44	55,22	71,28	36,86	46,56	56,54	74,07
Overtemperature of the flue gases [°C]	115											
Temperature of the flue gases at minimum output [°C]	43,3	43,3	38,1	38,1	59,4	59,4	58,8	58,8	42,9	42,9	40,1	40,1
Mass flow rate at the minimum heat output [m³/h] @ reduced power [kW]	0,886	0,886	1,04	1,071	0,606	0,606	0,951	0,982	1,292	1,34	1,632	1,67
Minimum nominal output [kW]	8,3	8,3	9,92	10,21	5,66	5,66	9,08	9,37	12,09	12,54	15,54	15,9
CO ₂ content in nominal conditions [%]	8,94	9,08	9,45	9,70	10,31	10,39	11,20	11,20	7,18	8,15	9,15	9,33
CO ₂ at the minimum heat output [%]	5,40	5,40	6,02	6,02	10,01	10,01	11,07	11,07	4,00	4,00	5,32	5,32
Loss of minimum permitted pressure (in air feed and flue gas pipe) [Pa]	15	23	19	34	-	-	-	-	-	-	-	-
P _{Loss} of maximum permitted pressure (in air supply and flue gas pipe) [Pa]	160	192	172	197	-	-	-	-	-	-	-	-
Maximum permitted pressure difference between combustion air inlet and flue gas outlet (including wind pressure) [Pa]	-	-	-	-	15	23	19	34	-	-	-	-
Maximum permitted combustion air temperature [°C]	-	-	-	-	45	45	45	45	-	-	-	-
	C9				50			65			80	
Minimum effective diameter of the flue/utility compartment [mm]	240											
Notes												
<p>C1: For the installation of the terminals on the wall and roof, refer to the specific instructions contained in the kits. The terminals emerge from separate combustion and air supply circuits within a square area of 50 cm.</p> <p>C3: The terminals of the separate combustion and air supply circuits must lie within a square area of 50 cm, and the distance between the surfaces of the two holes must be less than 50 cm.</p> <p>C4: The boilers in this configuration, with the relative connection pipes, can be connected to only one natural draught stack. Condensate flow inside the appliance is not permitted.</p> <p>C5: The terminals for combustion air supply and the evacuation of flue gases must not be installed on opposite walls of the building.</p> <p>C6: Condensate flow inside the appliance is permitted. Maximum permitted recirculation rate of 10% in windy conditions. The terminals for combustion air supply and the evacuation of flue gases must not be installed on opposite walls of the building.</p> <p> This type of configuration is not permitted in some countries; refer to the local regulations in force.</p> <p>C8: Condensate flow inside the appliance is not permitted.</p>												

PARAMETERS	UM	POWER EVO-X	
		METHANE GAS (G20)	LIQUID PROPANE GAS (G31)
Lower Wobbe index (at 15°C-1013 mbar)	MJ/m³S	45,67	70,69
Net calorific value	MJ/m³S	34,02	88
Nominal supply pressure	mbar (mm H2O)	20 (203,9)	37 (377,3)
Minimum supply pressure	mbar (mm H2O)	13 (132,6)	-
POWER EVO-X 50 DEP			
Burner: diameter/length	mm	70/160	70/160
Diaphragm: number of holes - hole diameter	n° - mm	1 - 6,5	1 - 5,1
Maximum gas flow rate (heating)	Sm³/h	3,69	-
	kg/h	-	2,71
Maximum gas flow rate (DHW)	Sm³/h	3,69	-
	kg/h	-	2,71
Minimum gas flow rate (heating)	Sm³/h	0,55	-
	kg/h	-	0,40
Minimum gas flow rate (DHW)	Sm³/h	0,55	-
	kg/h	-	0,40
Number of fan rotations (slow ignition)	rpm	4.000	4.000
Maximum number of fan rotations (heating)	rpm	7.300	7.100
Minimum number of fan rotations (heating)	rpm	1.750	1.650
POWER EVO-X 50			
Burner: diameter/length	mm	70/160	70/160
Diaphragm: number of holes - hole diameter	n° - mm	1 - 6,5	1 - 5,1
Maximum gas flow rate (heating)	Sm³/h	4,76	-
	kg/h	-	3,49
Maximum gas flow rate (DHW)	Sm³/h	4,76	-
	kg/h	-	3,49
Minimum gas flow rate (heating)	Sm³/h	0,55	-
	kg/h	-	0,40
Minimum gas flow rate (DHW)	Sm³/h	0,55	-
	kg/h	-	0,40
Number of fan rotations (slow ignition)	rpm	4.000	4.000
Maximum number of fan rotations (heating)	rpm	9.100	8.900
Minimum number of fan rotations (heating)	rpm	1.750	1.650
POWER EVO-X 65			
Burner: diameter/length	mm	70/150	70/150
Diaphragm: number of holes - hole diameter	n° - mm	2 - 5,6 (up) - 5,3 (down)	2 - 4,1 (up) - 4,1 (down)
Maximum gas flow rate (heating)	Sm³/h	5,82	-
	kg/h	-	4,27
Maximum gas flow rate (DHW)	Sm³/h	5,82	-
	kg/h	-	4,27
Minimum gas flow rate (heating)	Sm³/h	0,87	-
	kg/h	-	0,64
Minimum gas flow rate (DHW)	Sm³/h	0,87	-
	kg/h	-	0,64
Number of fan rotations (slow ignition)	rpm	3.000	2.400
Maximum number of fan rotations (heating)	rpm	6.800	6.300
Minimum number of fan rotations (heating)	rpm	1.850	1.750
POWER EVO-X 80			
Burner: diameter/length	mm	70/150	70/150
Diaphragm: number of holes - hole diameter	n° - mm	2 - 5,6 (up) - 5,3 (down)	2 - 4,1 (up) - 4,1 (down)
Maximum gas flow rate (heating)	Sm³/h	7,40	-
	kg/h	-	5,44
Maximum gas flow rate (DHW)	Sm³/h	7,40	-
	kg/h	-	5,44
Minimum gas flow rate (heating)	Sm³/h	0,87	-
	kg/h	-	0,64
Minimum gas flow rate (DHW)	Sm³/h	0,87	-
	kg/h	-	0,64
Number of fan rotations (slow ignition)	rpm	3.000	2.400
Maximum number of fan rotations (heating)	rpm	8.200	7.800
Minimum number of fan rotations (heating)	rpm	1.850	1.750

Parameter	Symbole	50 DEP	50	Unit
Seasonal space heating energy efficiency class	-	A	A	-
Water heating energy efficiency class	-	-	-	-
Rated heat output	Pnominal	34	44	kW
Seasonal space heating energy efficiency	η_s	93	92	%
Useful heat output				
At rated heat output and high-temperature regime (*)	P4	34,0	43,9	kW
At 30% of rated heat output and low-temperature regime (**)	P1	11,3	14,6	kW
Useful efficiency				
At rated heat output and high-temperature regime (*)	η_4	87,7	87,8	%
At 30% of rated heat output and low-temperature regime (**)	η_1	97,4	97,2	%
Auxiliary electricity consumption				
At full load	elmax	48,0	86,0	W
At part load	elmin	13,0	15,0	W
In Stand-by mode	PSB	3,8	3,8	W
Other parameters				
Stand-by heat loss	Pstby	36,8	34,7	W
Pilot flame energy consumption	Pign	-	-	W
Annual energy consumption	QHE	105	137	GJ
Sound power level, indoors	LWA	57	60	dB
Emissions of nitrogen oxides	NOx	30	33	mg/kWh
For combination heaters				
Declared load profile		-	-	
Water heating energy efficiency	η_{wh}	-	-	%
Daily electricity consumption	Qelec	-	-	kWh
Daily fuel consumption	Qfuel	-	-	kWh
Annual electricity consumption	AEC	-	-	kWh
Annual fuel consumption	AFC	-	-	GJ

(*) High-temperature regime means 60 °C return temperature at heater inlet and 80 °C feed temperature at heater outlet.

(**) Low temperature means for condensing boilers 30 °C, for low-temperature boilers 37 °C and for other heaters 50 °C return temperature (at heater inlet)

Parameter	Symbole	65	80	Unit
Seasonal space heating energy efficiency class	-	A	A	-
Water heating energy efficiency class	-	-	-	-
Rated heat output	Pnominal	54	68	kW
Seasonal space heating energy efficiency	η_s	92	92	%
Useful heat output				
At rated heat output and high-temperature regime (*)	P4	53,6	68,2	kW
At 30% of rated heat output and low-temperature regime (**)	P1	17,8	22,6	kW
Useful efficiency				
At rated heat output and high-temperature regime (*)	η_4	87,8	87,8	%
At 30% of rated heat output and low-temperature regime (**)	η_1	96,9	96,8	%
Auxiliary electricity consumption				
At full load	elmax	103,4	184,9	W
At part load	elmin	21,1	25,6	W
In Stand-by mode	PSB	3,8	3,8	W
Other parameters				
Stand-by heat loss	Pstby	34,5	34,5	W
Pilot flame energy consumption	Pign	-	-	W
Annual energy consumption	QHE	168	214	GJ
Sound power level, indoors	LWA	57	61	dB
Emissions of nitrogen oxides	NOx	41	48	mg/kWh
For combination heaters				
Declared load profile		-	-	
Water heating energy efficiency	η_{wh}	-	-	%
Daily electricity consumption	Qelec	-	-	kWh
Daily fuel consumption	Qfuel	-	-	kWh
Annual electricity consumption	AEC	-	-	kWh
Annual fuel consumption	AFC	-	-	GJ

(*) High-temperature regime means 60 °C return temperature at heater inlet and 80 °C feed temperature at heater outlet.

(**) Low temperature means for condensing boilers 30 °C, for low-temperature boilers 37 °C and for other heaters 50 °C return temperature (at heater inlet)

1.5 Circulator residual discharge head

The boiler is equipped with a high-efficiency modulating circulator (already hydraulically and electrically connected) whose effective available performance values are indicated in the graphs below. Modulation is managed by the board, via parameter P4.05 (INSTALLER access level).

The boiler has an anti-lockout system that launches an operating cycle after 24 hours of stoppage in any operating status.

 The “anti-locking” function is only activated when the boiler is electrically powered.

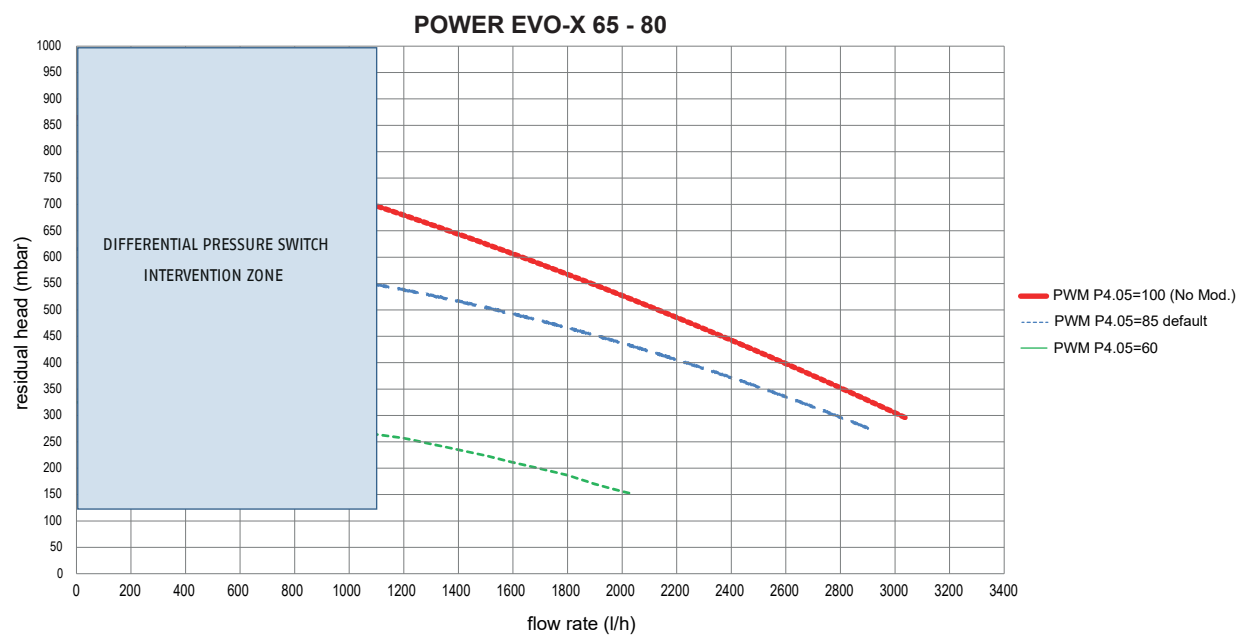
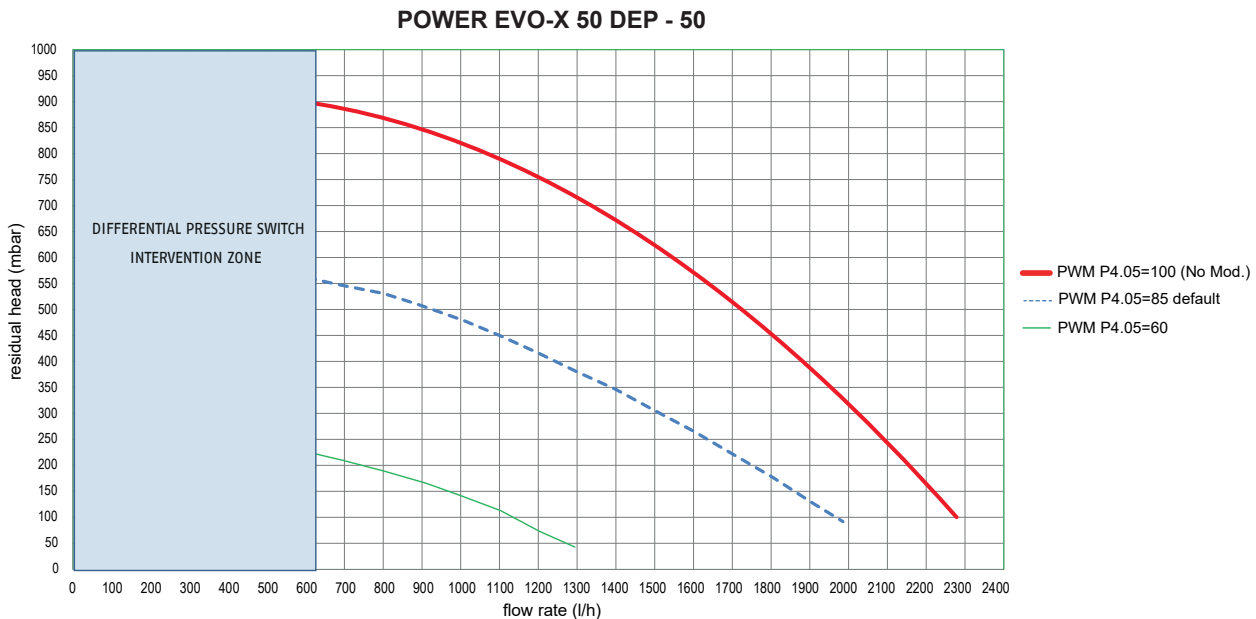

1.6 Variable speed circulator

The modulating circulator function is only active in heating mode. When switched to DHW, the circulator always works at the maximum speed. The modulating circulator function only applies to the circulator of the boiler, not to circulators of any external devices that may be connected (e.g. a relaunch circulator).

In this mode, the boiler board determines what flow rate value to adopt according to the instantaneous flow rate supplied by the boiler. Go to menu **P4**, parameter P4.05, if you want to change the modulation value:

- 100= no modulation
- 60 = max modulation
- 85= default value

1.7 Manual circulator reset

If a manual reset is needed, proceed as follows:

- remove the circulator plug
- use a flathead screwdriver to rotate the shaft, taking care not to force the seat.

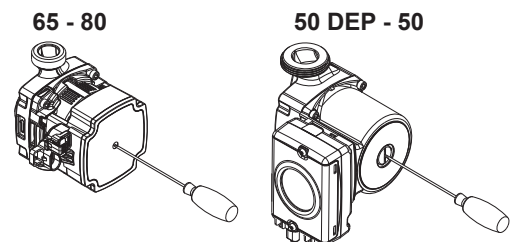

1.8 Water circuit

POWER EVO-X 50 DEP - 50

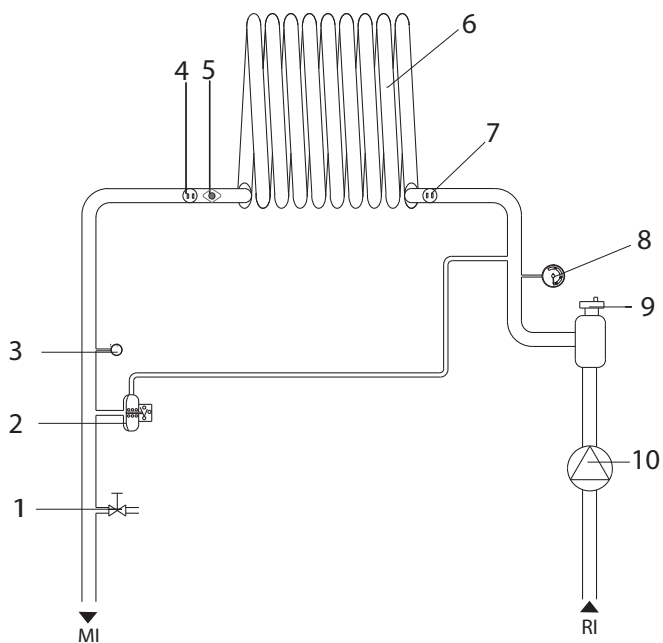

POWER EVO-X 65 - 80

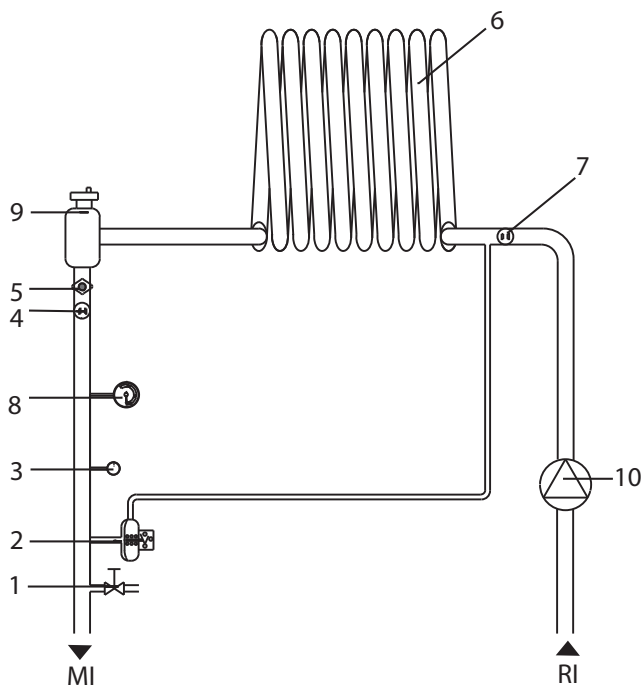

Key

- RI** Heating return line
- MI** Heating delivery line
- 1** Degassing unit tap/boiler discharge
- 2** Heating pressure switch
- 3** Pressure transducer
- 4** Flow sensor
- 5** Safety thermostat
- 6** Heat exchanger
- 7** Return probe
- 8** Pressure gauge
- 9** Air vent valve
- 10** Circulator

Probes in the boiler

- 1** Safety thermostat
- 2** NTC delivery probe
- 3** Flue gas probe
- 4** NTC return line probe

POWER EVO-X 50 DEP - 50

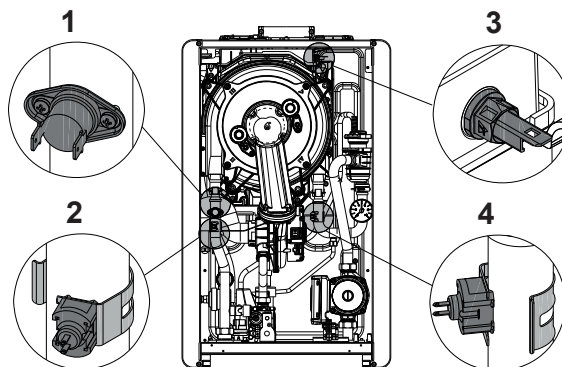

POWER EVO-X 65 - 80

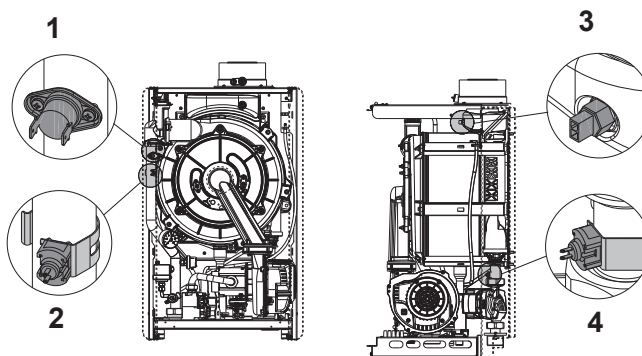







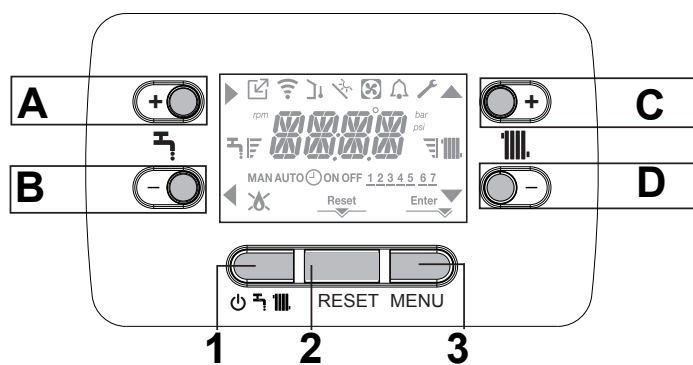















Resistive values of the NTC probes with variations in the temperature

Temperature °C Tolerance test ±10%	Resistance Ω	Temperature °C Tolerance test ±10%	Resistance Ω
-20	67523	45	4896
-15	53254	50	4147
-10	42291	55	3525
-5	33808	60	3011
0	27700	65	2582
5	22290	70	2224
10	18070	75	1922
15	14740	80	1668
20	12110	85	1451
25	10 000	90	1267
30	8300	95	1110
35	6924	100	975
40	5810		

1.9 Control panel



A	Normally used to increase the DHW temperature value, but when the arrow  is highlighted it acts as a confirmation button
B	Normally used to decrease the DHW temperature value, but when the arrow  is highlighted it acts as a back/annul button
C	Normally used to increase the heating water temperature value, but when the arrow  is highlighted it allows you to navigate menu P1
D	Normally used to decrease the heating water temperature value, but when the arrow  is highlighted it allows you to navigate menu P1
A+C	Access to the clock setting menu (see paragraph “3.2 Programming the boiler”)
1	Used to modify the boiler operating status (OFF, SUMMER and WINTER)
2	Used to reset the alarm status, or to interrupt the venting cycle
3	Used to access the INFO menus and menu P1. When the  icon appears on the display, this button has an ENTER function and is used to confirm the value set while programming a technical parameter
1+3	Button lock and release
2+3	Used when the boiler is OFF, to activate the flue gas analysis function (CO)

	Indicates the connection to a remote device (OT or RS485)
	Indicates the connection to a wi-fi device
	Indicates the presence of an outdoor temperature sensor
	Indicates the activation of special DHW functions, or the presence of a solar thermal management system
	Lights up if an alarm is triggered
	Lights up along with the icon  in the event of a fault (apart from flame and water alarms)
	Indicates the presence of a flame ( in the event of a flame lockout)
	Lights up for alarms requiring a manual reset by the operator
	Lights up when confirmation is required
	When this icon is active, the “confirm” function of button A is active
	When this icon is active, the “back/annul” function of button B is active
	When this icon is active, the user can navigate the menu or increase the value of the selected parameter
	When this icon is active, the user can navigate the menu or decrease the value of the selected parameter
	Lights up if heating mode is active; flashes with a heating request in progress
	Lights up if DHW mode is active; flashes with a DHW request in progress
	Indicate the setpoint defined (1 notch=minimum value, 4 notches=maximum value)
1 2 3 4 5 6 7	Indicate the days of the week
AUTO ON	NOT AVAILABLE ON THIS MODEL
MAN ON	NOT AVAILABLE ON THIS MODEL
MAN OFF	NOT AVAILABLE ON THIS MODEL

 The DHW function is only shown on the display in cases B and C - see paragraph “1.1 Boiler description”

The control panel acts as a machine interface, displaying the system settings and providing access to the parameters.

The configuration MENU is organised with a multi-level tree structure. An access level has been fixed for each sub-menu: USER level always available; TECHNICAL level protected by means of a password. Below is a summary of the SETTINGS MENU tree structure.

Some of the information might not be available depending on the access level, machine status, system configuration or software revision.

The following table lists the programmable parameters; if the adjustment board does not support the relative function, the interface returns an error message.

1.10 Structure menu

For a detailed explanation of the parameters, refer to paragraph "1.11 Description of the parameters".

Menu	Parameters	Scrolling message only if parameter P1.05 = 1	Value	Password level	Value set in the factory	Personalised values	
P1		SETTINGS					
	P1.01	LANGUAGES	0 IT 1 RO 2 FR 3 EN 4 SR 5 HR	6 ES 7 EL 8 BG 9 PL 10 SL	USER		
	P1.02	TIME		USER			
	P1.03	TIME PROGRAM	NOT AVAILABLE				
	P1.05	SCROLLING	0 / 1	USER	0		
	P1.07	SEASON AUTO-CHANGE	0 / 1	USER	0		
	P1.08	T TRANSITION TO SUM	P1.09/40°C	USER	20°C		
	P1.09	T TRANSITION TO WIN	0°C / P1.08	USER	15°C		
P1.08 and P1.09 visible only if P1.07 =1							
P3		CONFIGURATION					
	P3.01	HYDRAULIC CONFIGURATION	0 / 1 / 2 / 3 / 4	INSTALLER	0 (°)		
	P3.02	WATER PRESSURE TRANSDUCER	0 / 1	SERVICE	1		
	P3.03	AUTO FILL ENABLE	0 / 1	SERVICE	0		
	P3.04	BEGIN SYSTEM FILLING	NOT AVAILABLE ON THIS MODEL				
	P3.05	AIR PURGING CYCLE	0 / 1	SERVICE	1		
	P3.06	MIN FAN SPEED	1.200-3.600	INSTALLER	see technical data table		
	P3.07	MAX FAN SPEED	3.700-9.999	INSTALLER	see technical data table		
	P3.08	SLOW IGNITION ADJUSTMENT	MIN-MAX	INSTALLER	see technical data table		
	P3.09	MAX FAN SPEED HTG	MIN - MAX	INSTALLER	see technical data table		
	P3.10	RANGE RATED	NOT AVAILABLE ON THIS MODEL				
	P3.11	CONFIG AUX	0 / 1 / 2	INSTALLER	0		
	P3.12	EXHAUST PROBE RESET	0 / 1	INSTALLER	0		
	P3.13	IGNITION SPEED IN RESTART AFTER SHUTDOWN DUE TO TEMPERATURE	MIN FAN SPEED/ SLOW IGNITION ADJUSTMENT	INSTALLER	min value between 3.600 rpm and P308		
P4		HEATING					
	P4.01	HYST OFF HIGH TEMP	2 - 10	SERVICE	5		
	P4.02	HYST ON HIGH TEMP	2 - 10	SERVICE	5		
	P4.03	HYST OFF LOW TEMP	2 - 10	SERVICE	3		
	P4.04	HYST ON LOW TEMP	2 - 10	SERVICE	3		
	P4.05	PUMP CONTROL TYPE	60 - 100	INSTALLER	85		
	P4.08	OT+ CASCADE CONTROL	NOT AVAILABLE ON THIS MODEL				
	P4.09	SCREED FUNCTION	0 / 1	INSTALLER	0 (boiler in OFF and P4.15=1)		
	P4.10	ANTI CYCLE FUNCTION	0 - 20 min	INSTALLER	3 min		
	P4.11	RESET CH TIMERS	0 / 1	INSTALLER	0		
	P4.12	MAIN ZONE ACTUATION TYPE	0 / 1	INSTALLER	0		
	P4.13	MAIN ZONE BE16 ADDRESS	1 - 6	INSTALLER	3		
	P4.14	MAIN ZONE HYDRAULIC CONF	0 / 1	INSTALLER	0		
	P4.15	MAIN ZONE LOW TEMP	0 / 1	INSTALLER	0		
	P4.16	MAX CH SET	HT: MIN CH SET - 80 LT: MIN CH SET - 45,0	INSTALLER	80 45,0		
	P4.17	MIN CH SET	HT: 20 - MAX CH SET LT: 20 - MAX CH SET	INSTALLER	40 20		
	P4.18	WEATHER COMP ENABLE	0 (default)/1	INSTALLER	0		
	P4.19	WEATHER COMP CURVE	1,0-3,0 → HT 0,2-0,8 → LT	INSTALLER	2,0		
	P4.20	NIGHT COMPENSATION	0 / 1	INSTALLER	0		
	P4.21	POR MAIN ZONE	DO NOT MODIFY				0

HT = HIGH TEMPERATURE ● LT = LOW TEMPERATURE

(°) 0 = HEATING ONLY - 1 = INSTANTANEOUS BOILER WITH FLOW SWITCH - 2 = INSTANTANEOUS BOILER WITH FLOW METER - 3 = STORAGE TANK WITH PROBE - 4 = STORAGE TANK WITH THERMOSTAT

Menu	Parameters	Scrolling message only if parameter P1.05 = 1	Value	Password level	Value set in the factory	Personalised values
	P4.22	MAN AUTO MAIN ZONE	DO NOT MODIFY		0	
	P4.23	ZONE1 ENABLE	0 / 1	INSTALLER	0	
	P4.24	ZONE1 BE16 ADDRESS	1 - 6	INSTALLER	1	
	P4.25	ZONE1 HYDRAULIC CONFIG	0 / 1	INSTALLER	0	
	P4.26	ZONE1 LOW TEMP	0 / 1	INSTALLER	0	
	P4.27	ZONE1 SET	ZONE1 MIN CH SET - ZONE1 MAX CH SET	USER 	40 - 80,5	
	P4.28	ZONE1 MAX CH SET	HT: ZONE1 MIN CH SET - 80,5 LT: ZONE1 MIN CH SET - 45,0	INSTALLER	80,5	
	P4.29	ZONE1 MIN CH SET	HT: 40 - ZONE1 MAX CH SET LT: 20 - ZONE1 MAX CH SET	INSTALLER	40	
	P4.30	WEATHER COMP ZONE 1	0 / 1	INSTALLER	0	
	P4.31	WEATHER COMP CURVE ZONE 1	1,0-3,0 → HT 0,2-0,8 → LT	INSTALLER	2,0	
	P4.32	ZONE1 NIGHT COMP	0 / 1	INSTALLER	0	
	P4.33	BUILDING TYPE	5min ÷ 20min	INSTALLER	5min	
	P4.34	EXTERNAL PROBE REACTIVITY	0+255	INSTALLER	20	
P5		DHW (°)				
	P5.01	ANTI LEGIONELLA	0/2	INSTALLER	0	
	P5.02	DELAY FIRST ANTI LEGIONELLA	0 h/24h	INSTALLER	0 h	
	P5.03	DELIVERY TEMP FOR ANTILEG	65,0 °C/ 85,0 °C	INSTALLER	80,0 °C	
	P5.04	HYST WATER TANK ON	0,0 °C/ 10,0 °C	INSTALLER	5,0 °C (ext) - 0,0 °C (int)	
	P5.05	HYST WATER TANK OFF	0,0 °C/ 10,0 °C	INSTALLER	5,0 °C (ext) - 0,0 °C (int)	
	P5.06	DELIVERY WATER TANK TEMP	50,0 °C/ 85,0 °C	INSTALLER	80,0 °C (if external water tank and par. 507=0)	
	P5.07	SLIDING WATER TANK DELIVERY	0 / 1	INSTALLER	0	
	P5.08	MIN DHW TEMP	37,5 °C/ 49,0 °C	INSTALLER	37,5°C	
	P5.09	MAX DHW TEMP	49,0 °C/ 60,0 °C	INSTALLER	60,0°C	
	P5.12	DHW POST-CIRC. ON HEAT. RETURN	0 / 1	SERVICE	0	
	P5.13	RETURN POST-CIRC TIME	1/255	SERVICE	6	
	P5.14	P5.14 (SIMULTANEOUS DHW AND HEATING)	0 / 1	SERVICE	0	
	P5.15	P5.15 (OFFSET DHW SETPOINT)	0°C / 10°C	SERVICE	0°C	
P6		SOLAR				
	P6.01	ENABLE SOLAR TANK MANAGEMENT	0 / 1	INSTALLER	0	
	P6.02	MAX TANK TEMPERATURE	10 ÷ 130	INSTALLER	60°C	
	P6.03	PUMP ON DELTA T	PUMP OFF DELTA T 30°C	INSTALLER	8°C	
	P6.04	PUMP OFF DELTA T	4°C PUMP ON DELTA T	INSTALLER	4°C	
	P6.05	INTEGRATION DELAY	0min - 199min	INSTALLER	0 min	
	P6.06	COLLECTOR T MIN	(--)/-30°C - 0	INSTALLER	(--)	
	P6.07	COLLECTOR T MAX	COLLECTOR T PROT - 180°C	INSTALLER	110°C	
	P6.08	COLLECTOR T PROT	80°C - COLLECTOR T MAX	INSTALLER	110°C	
	P6.09	COLLECTOR T AUTH	COLLECTOR T LOCK - 95°C	INSTALLER	40°C	
	P6.10	COLLECTOR T LOCK	-20°C - COLLECTOR T AUTH	INSTALLER	35°C	
	P6.11	PWM COLL PUMP	0min - 30min	INSTALLER	0 min	
	P6.12	TANK COOLING	0/1	INSTALLER	0	
	P6.13	SOLAR PUMP MODE	0/1/2	INSTALLER	0	
P7		SERVICE				
	P7.06	SERVICE CALL FUNCTION	0 / 2	SERVICE	2	
	P7.07	SERVICE DEADLINE	0 / 255	SERVICE	52	
	P7.08	HIGH EFFICIENCY MODE	0 / 1	SERVICE	0	
P8		CONNECTIVITY				
	P8.01	BUS 485 CONFIG.	0 / 1 / 2	SERVICE	0	
	P8.03	OT+ CONFIG.	0 / 1	SERVICE	1	
P9		CASCADE				
	P9.01	CASCADE CONFIGURATION	0/1/2/3/4	SERVICE	0	
	P9.02	ADDITIONAL BOILER FLOW RANGE	30/95	SERVICE	80	

(°) Menu P5 DHW is only visible when parameter P3.01 Hydraulic configuration = 3 or 4 - case C or B

1.11 Description of the parameters

Some of the following functions might not be available depending on the type of machine and the access level.

PARAMETER	DESCRIPTION
P 1.01	To set the desired language 0 IT - 1 RO - 2 FR - 3 EN - 4 SR - 5 HR - 6 ES - 7 EL - 8 BG - 9 PL - 10 SL
P1.02	To set TIME and DATE
P1.03	Not available
P1.05	To set the scrolling text
P1.07	See paragraph "Auto season change Winter - Summer"
P1.08	See paragraph "Auto season change Winter - Summer"
P1.09	See paragraph "Auto season change Winter - Summer"
P3.01	To set the type of hydraulic configuration of the boiler: 0 = HEATING ONLY - 1 = INSTANTANEOUS FLOW SWITCH - 2 = INSTANTANEOUS FLOW METER - 3 = STORAGE TANK WITH PROBE - 4 = STORAGE TANK WITH THERMOSTAT Factory value = 0. If the electronic board is replaced, make sure this parameter is set at 0
P3.02	To set the type of water pressure transducer: 0 = water pressure switch - 1 = pressure transducer Factory value = 1, do not alter. If the electronic board is replaced, make sure this parameter is set at 1.
P3.03	To enable the "semi-automatic filling" function when a pressure transducer and filling solenoid valve are installed in the boiler. Factory value = 0, do not alter. If the electronic board is replaced, make sure this parameter is set at 0.
P3.04	Only appears if P3.03 = 1. NOT AVAILABLE ON THIS MODEL.
P3.05	To disable the vent cycle function. Factory value = 1. Set the parameter at 0 to disable the function.
P3.06	To alter the minimum number of fan rotations.
P3.07	To alter the maximum number of fan rotations.
P3.08	To regulate slow ignition (it can be programmed within the range P3.06 - P3.07)
P3.09	To alter the maximum fan rpm in heating mode (it can be programmed within the range P3.06 - P3.07)).
P3.10	To modify the heat output in heating mode. NOT AVAILABLE ON THIS MODEL.
P3.11	To configure the operation of a supplementary relay (only if board BE09 (accessory kit) is installed) in order to bring a phase (230V AC) to a second heating pump (supplementary pump) or to a zone valve. Factory value = 0, but it can be programmed within the range 0 - 2 with the following meaning: P3.11= 0 - control depends on the configuration of the wiring of the BE09 board (jumper cut: supplementary pump - jumper present: zone valve). P3.11= 1 - control of the zone valve P3.11= 2 - control of the supplementary pump
P3.12	Used to reset the operating hours counter in certain conditions (for more details, see "Faults and reporting", fault E091). Factory value = 0. Bring the value to 1 to reset the flue gas probe hour counter after the cleaning of the primary heat exchanger. When the reset procedure has been completed, the parameter will return automatically to 0.
P3.13	This parameter allows the regulation of slow ignition in burner re-ignitions following shutdowns due to the set point temperature being reached. Adjustment is possible between the minimum fan speed value (P3.06) and the speed value during slow ignition (P3.08).
P4.01	For high temperature systems, this parameter allows the setting of the hysteresis value used by the adjustment board to calculate the delivery temperature for burner switch-off. SWITCH-OFF TEMPERATURE = HEATING SETPOINT + P4.01. Factory value = 5°C, but it can be set within the range 2 - 10°C.
P4.02	For high temperature systems, this parameter allows the setting of the hysteresis value used by the adjustment board to calculate the delivery temperature for burner ignition: IGNITION TEMPERATURE = HEATING SETPOINT - P4.02. Factory value = 5°C, but it can be set within the range 2 - 10°C.
P4.03	For low temperature systems, this parameter allows the setting of the hysteresis value used by the adjustment board to calculate the delivery temperature for burner switch-off: SWITCH-OFF TEMPERATURE = HEATING SETPOINT + P4.03. Factory value = 3°C, but it can be set within the range 2°C - 10°C.
P4.04	For low temperature systems, this parameter allows the setting of the hysteresis value used by the adjustment board to calculate the delivery temperature for burner ignition: IGNITION TEMPERATURE = HEATING SETPOINT - P4.04. Factory value = 3°C, but it can be set within the range 2°C - 10°C.
P4.05	The speed of the pump is PROPORTIONAL to that of the fan and in DHW it is always at max. The parameter can be set in the range 60-100 100= no modulation - 60 = max modulation - 85= default value
P4.08	Used to set the boiler for cascade applications via an OT+ signal.
P4.09	Used to activate the screed heater function (for more details, refer to paragraph "Screed heater function"). Factory value = 0, with the boiler OFF. Set the value at 1 to activate the screed heater function on the low temperature heating areas. The parameter returns automatically to 0 when the screed heater function ends, but the function can also be interrupted by manually setting the value at 0.
P4.10	Used to modify the forced heating off timer with regards the delay time for re-igniting the burner if it is OFF because the heating temperature has been reached. Factory value = 3 minutes, but it can be set at a value between 0 and 20 min.
P4.11	Used to annul the HEAT TIME RESET function and REDUCED MAX. HEATING OUTPUT TIMER, during which the fan speed is limited to a range between the minimum and 60% of the max. heating output set, with a 10% increase every 15 minutes. Factory value = 0. Set at 1 to reset the timer.
P4.12	This parameter allows you to configure the system to manage a mixing valve and an additional pump on the main heating system (the use of the BE16 accessory board is required, not supplied as standard). The factory setting for this parameter is 0, set to 1 for the connection of a BE16 board. Note: this parameter cannot be changed when an OT+ chronothermostat is connected.
P4.13	When P4.12 = 1, this parameter allows you to set the address of the BE16 board. The factory setting for this parameter is 3 and can be set within the 1 - 6 range. Note: see the instruction sheet of the BE16 accessory board for more information about the use of this parameter.
P4.14	When P4.12 = 1, this parameter allows you to set the hydraulic configuration of the main heating zone. The factory setting for this parameter is 0 and allows a direct zone to be managed, set the parameter to 1 for the management of a mixed zone. Note: see the instruction sheet of the BE16 accessory board for more information about the use of this parameter.
P4.15	Used to specify the type of area to be heated. Choose from the following options: 0 = HIGH TEMPERATURE (factory setting) 1 = LOW TEMPERATURE
P4.16	Used to specify the maximum heating setpoint value that can be set: range 20°C - 80°C, default 80.5°C for high temperature systems range 20°C - 45°C, default 45°C for low temperature systems. Note: the value of P4.16 cannot be lower than P4.17.
P4.17	This parameter is used to specify the minimum heating setpoint value that can be set: range 20°C - 80.5°C, default 40°C for high temperature systems range 20°C - 45°C, default 20°C for low temperature systems Note: the value of P4.17 cannot be higher than P4.16.
P4.18	Used to activate temperature control when the system is connected to an outdoor temperature sensor. Factory value = 0, the boiler always works with a fixed point. If the parameter is set at 1 and an outdoor temperature sensor is connected, the boiler works in temperature control mode. If the outdoor temperature sensor is disconnected, the boiler always works with a fixed point. See paragraph "Setting the thermoregulation" for more details about this function.
P4.19	Used to set the number of the compensation curve used by the boiler in temperature control mode. Factory value = 2.0 for high temperature systems, and 0.5 for low temperature systems. The parameter can be programmed within the range 1.0 - 3.0 for high temperature systems, or 0.2 - 0.8 for low temperature systems. See paragraph "Setting the thermoregulation" for more details about this function.
P4.20	Activates the "night-time compensation" function. The default value is 0. Set at 1 to activate the function. See paragraph "Setting the thermoregulation" for more details about this function.
P4.21- P4.22	Do not modify
P4.23	This parameter allows you to activate the management of an additional heating zone (the use of the BE09 accessory board is required, not supplied as standard). The default value is 0, set to 1 to activate the function. Ne: this parameter cannot be changed when an OT+ chronothermostat is connected.

P4.24	When P4.23 = 1, this parameter allows you to set the address of the BE16 board of zone 1. The factory setting is 1 and can be set within the 1 - 6 range. Note: see the instruction sheet of the BE16 accessory board for more information about the use of this parameter.
P4.25	When P4.23 = 1, this parameter allows you to set the hydraulic configuration of heating zone 1. The factory setting for this parameter is 0 and allows you to manage a direct zone, set to 1 to manage a mixed zone. Note: see the instruction sheet of the BE16 accessory board for more information about the use of this parameter.
P4.26	When P4.23 = 1 this parameter allows you to specify the type of zone1 to be heated. It is possible to choose from the following options: 0 = HIGH TEMPERATURE (factory setting) 1 = LOW TEMPERATURE
P4.27	When P4.23 = 1, this parameter allows you to the setpoint value of heating zone 1. The factory setting for this parameter is P4.28 and can be programmed within the P4.29 and P4.28 range.
P4.28	This parameter allows you to specify the maximum heating setpoint that can be set for zone 1: range 20°C - 80.5°C, default 80.5°C for high temperature systems range 20°C - 45°C, default 45°C for low temperature systems. Note: the P4.28 value cannot be less than P4.29.
P4.29	Questo parametro consente di specificare il minimo valore di setpoint riscaldamento impostabile per la zona 1 range 20°C - 80.5°C, default 40°C for high temperature systems range 20°C - 45°C, default 20°C for low temperature systems. Note: the P4.29 value cannot be higher than P4.28.
P4.30	This parameter allows you to activate thermoregulation mode for zone 1 when the system has an outdoor temperature sensor connected. The factory setting is 0, the boiler always operates for zone 1 at a fixed point; to have the boiler work in climate mode connect an outdoor temperature sensor and set the parameter to 1, connect an outdoor temperature sensor. With an outdoor temperature probe disconnected the boiler always operates at a fixed point. See paragraph "Setting the thermoregulation" for more details.
P4.31	This parameter allows you to set the number of the compensation curve for zone 1 used by the boiler when in climatic mode. The factory setting for this parameter is 2.0 for high temperature systems and 0.5 for low temperature ones. The parameter can be set with the range 1.0 - 3.0 for high temperature systems, 0.2 - 0.8 for low temperature ones. See paragraph "Setting the thermoregulation" for more details.
P4.32	This parameter allows you to activate "night compensation" for zone 1. The default value is 0, set to 1 to activate the function. See paragraph "Setting the thermoregulation" for more details.
P4.33	Frequency with which the value of the calculated outdoor temperature for thermoregulation is updated, a low value for this value will be used for buildings that have little insulation.
P4.34	Frequency for the reading of the outdoor temperature value by the probe.
P5.01	This parameter allows you to activate the "antilegionella" function as described in paragraph "Anti-legionella function (only if connected to a storage cylinder with probe)". The factory setting of this parameter is 0 (function disabled). Set the value to 1 to activate the weekly antilegionella function, the is carried out the third day of the week at 03:00 am. Set the value to 2 to activate the daily antilegionella function, the is carried out every day of the week at 03:00 am.
P5.02	This parameter indicates the delay in hours with respect to the first time the anti-legionella function is followed.
P5.03	Is the boiler flow temperature when the anti-legionella function is active.
P5.04	The water tank charging request is activated when the temperature measured by the water tank probe is lower than the water tank setpoint - par. P5.04
P5.05	The water tank charging request is deactivated when the temperature measured by the water tank probe is greater than the water tank setpoint + par. P5.05
P5.06	Parameter for setting the boiler delivery temperature to the domestic hot water tank
P5.07	This parameter allows you to activate the SLIDING OUTLET function to modify the delivery setpoint used by the boiler, when there is a domestic hot water request (only when a water tank with a probe is connected, C case). The factory setting for this parameter is 0 (function deactivated), set the parameter to 1 to activate the function. See paragraph "Sliding delivery (only if water tank connected)" for more details.
P5.08	To set the minimum DHW setpoint
P5.09	To set the maximum DHW setpoint
P5.12	This value can be used to enable/disable the DHW post-circulation function with inhibition of heating start-up.
P5.13	This value sets the duration of the DHW post-circulation when the DHW post-circulation function with inhibition of heating start-up is enabled.
P5.14	See paragraph "Special function: simultaneous DHW and HEATING"
P5.15	See paragraph "Special function: simultaneous DHW and HEATING"
P6.01	This parameter is used to enable the management of a solar storage tank (only for the storage tank with probe - case C), it is necessary to use the BE15 accessory card. The factory value is 0 = solar storage tank management disabled, set the parameter to 1 to enable the function.
P6.02	The parameter allows you to set the maximum temperature of the upper part of the storage tank. The factory setting is 60°C. The parameter can be programmed in the range 10°C ÷ 130°C
P6.03	The parameter allows you to manage the temperature difference between the collector probe and the lower storage tank sensor for heating the storage tank (activation of the solar pump). The factory setting is 8°C. The parameter can be programmed in the range 4°C ÷ 30°C. Note: P6.03 value must be greater than P6.04.
P6.04	The parameter allows you to manage the temperature difference between the collector probe and the lower storage tank sensor for for interrupting the thermal load of the storage tank (stopping the solar pump). The factory setting is 4°C. The parameter can be programmed in the range 4°C ÷ 30°C. Note: P6.04 value must be greater than P6.03.
P6.05	The parameter allows you to set the delay time for solar integration by the boiler. The factory setting is 0 min. The parameter can be programmed in the range 0min ÷ 180min
P6.06	With this parameter you set the minimum collector temperature to activate the solar collector antifreeze function. The factory setting is: - ° C (solar collector antifreeze disabled). The parameter can be programmed in the range -30°C ÷ + 5°C.
P6.07	Parameter for setting the maximum collector temperature for solar collector pump block (system protection). The pump is then enabled as soon as the collector temperature drops below [P6.07 - 10°C]. The factory setting is 110°C. The parameter can be programmed in the range 80 ° C ÷ 180°C. Note: P6.07 value must be greater than P6.08.
P6.08	Parameter for setting the maximum collector temperature to activate the solar collector cooling function. The factory setting is 110 ° C. The parameter can be programmed in the range 80°C ÷ 180°C. Note: P6.08 value must be less than P6.07.
P6.09	Parameter for setting the minimum temperature for enabling the solar collector pump. The factory setting is 40 ° C. The parameter can be programmed in the range -20°C ÷ + 95°C. Note: P6.09 value must be greater than P6.10
P6.10	This parameter allows you to set the minimum temperature for disabling the solar collector pump. The factory setting is 35 ° C. The parameter can be programmed in the range -20°C ÷ + 95°C. Note: P6.10 value must be less than P6.09.
P6.11	This parameter allows you to set the PWM modulation period of the solar pump. The factory setting is 0min (solar collector pump modulation function disabled). The parameter can be programmed in the range 0min ÷ 30min.
P6.12	Parameter for enabling / disabling the boiler cooling function; you can choose between the following two options. 0 = FUNCTION NOT ACTIVE (factory set value) 1 = FUNCTION ACTIVE

P6.13	Parameter for configuring solar collector pump operation; you can choose between the following three options: 0 = OFF (factory setting) ==> the solar collector pump is always off 1 = ON ==> the solar collector pump is always on 2 = AUTO ==> the solar collector pump switches on and off according to the rules of solar management
P7.01	Used to activate the storage of an alarm history. Default 0: the value automatically changes to 1 after 2 hours of operation
P7.06	This parameter allows periodic control of the boiler according to an operating period set in parameter P7.07. There are three setting values: 0 = function disabled 1 = function enabled according to the following rule: if P7.07 < 4 the display shows the CFS signal if P7.07 = 0 the display shows the SFS (STOP FOR SERVICE) signal which indicates the permanent inhibition of all requests for heating and domestic hot water. Not resettable 2 = function enabled: when P7.07 = 0 the display shows the CFS signal without any stop of operation In this condition, the INFO menu (line I044), displays the number of days that have passed since the CFS signal appeared (P7.07 = 0)  The CFS signal occurs at 10 min intervals for the duration of 1 min, 1 month before the end of the period set in parameter P7.07.
P7.07	Fixed operating period for the service call (parameter P7.06)
P7.08	Automatic function that is activated at the first power supply or after 60 days of non-use (electrically powered boiler). In this mode the boiler, for 60 minutes, limits the heating power to a minimum and the maximum DHW temperature to 55°C. Activating the chimney sweep temporarily disables this function. During execution, the water pressure icon flashes (0.5sec on – 0.5sec off). 0 = FACTORY VALUE, high efficiency mode disabled 1 = high efficiency mode enabled
P8.01	This parameter is used to enable remote management of the boiler (in case of REC10H). There are three setting values: 0 = FACTORY VALUE. The interface on the machine is operational, remote control via ModBus is enabled 1 = the interface on the machine is operational, remote control via ModBus is disabled 2 = the interface on the machine is not operational, the remote control is enabled via REC10H. Only the MENU key remains active to modify parameter P8.01.
P8.03	This parameter is used to enable the remote control of the boiler via an OpenTherm device: 0 = OT+ function disabled (remote boiler control via an OT+ device is not possible). If this parameter is set at 0, the OT+ connection (if present) will be immediately interrupted 1 = FACTORY VALUE. OT+ function enabled (an OT+ device can be connected for remote boiler control). When an OT+ device is connected to the boiler, the message "Ot" appears on the display.
P9.01	Cascade configuration - When the parameter is programmed at 0 the boiler operates in a single boiler configuration, it is not provided in a cascade system. Setting the parameter to 1,2,3,4 for each module defines the unique address to identify the boiler in the cascade system. By programming parameter P9.01=1 and using a single boiler, the boiler can be used individually by exploiting the cascade architecture devices (REC12 + MSC), in this case, however, the boiler will have the limitations indicated for cascade configurations (P9.01 = 1 or 2 or 3 or 4).
P9.02	Additional boiler flow range - Used only when the boiler is in a cascade system to limit the calculation of the temperature control of each individual boiler. Default value 80 - Modify only in special applications where it is necessary to have the flow temperature up to 90°C, in these cases set to 90°C

1.12 Configuring a system with REC10

The **POWER EVO-X** boiler, in single application, can be inserted in a system where a REC10 or REC10H and BE management boards are present (BE15 for solar thermal management, BE16 for management of direct or mixed zones, BE17 for of the DHW/system diverter relative to the heat pump and/or photovoltaic. Use the CE4 connector located under the boiler shelf to connect the remote control. Set the parameter P8.01 (BUS 485 CONFIG.) = 2.

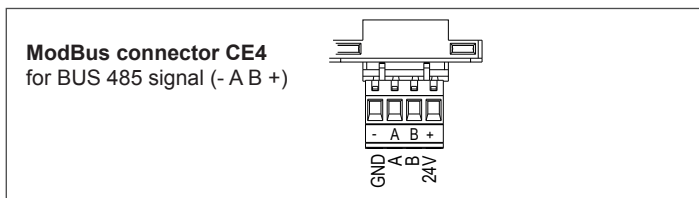

If a REC10 or REC10H is present, for system parameterisation, refer to the programming manual of the REC itself.

1.12.1 Particular programming of parameter P9.01

The boiler provides for the possibility of special technical programming. By programming parameter P9.01=1 and using a single boiler, the boiler can be used individually by exploiting the devices of the cascade architecture (REC12 + MSC), in this case, however, the boiler will have the limitations indicated for the cascade configurations (P9.01 = 1 or 2 or 3 or 4).

1.13 Boiler cascade configuration

POWER EVO-X can be inserted in a cascade control system from 2 to 4 boilers. Use the **MB02** connector of the boiler board and the **X1** connector of the MSC board to make the connection between the modules and the cascade manager.

The REC12 performs the system control function.

Program parameter P9.01 by setting it to a value between 1 and 4. This value identifies the unique address of the boiler in the cascade system.

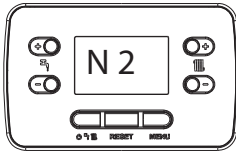

⚠ If two identical addresses are assigned to the units by mistake, a communication error code will appear on the display.

Once this operation has been carried out, with the boiler not in heating request and after a few minutes, the display will show the value of its address.

Refer to the REC12 manual to continue with system programming.

When the boiler is identified as part of a cascade system, some functions/displays are simplified or inhibited:

- the boiler works only in HEATING ONLY mode
- the local thermoregulation functions are disabled
- the SUMMER and WINTER states are disabled
- the direct management of the HEATING SETPOINT is disabled the heat request arrives only from the external system in the form of a percentage of power supplied by the boiler (percentage in relation to the MAXIMUM to MINIMUM programmed in the single boiler)
- in addition to the traditional rules, the management of boiler ventilation can also be managed directly by the external system
- disabling the screed warmer function
- disable OPENTHERM channel (OT +).

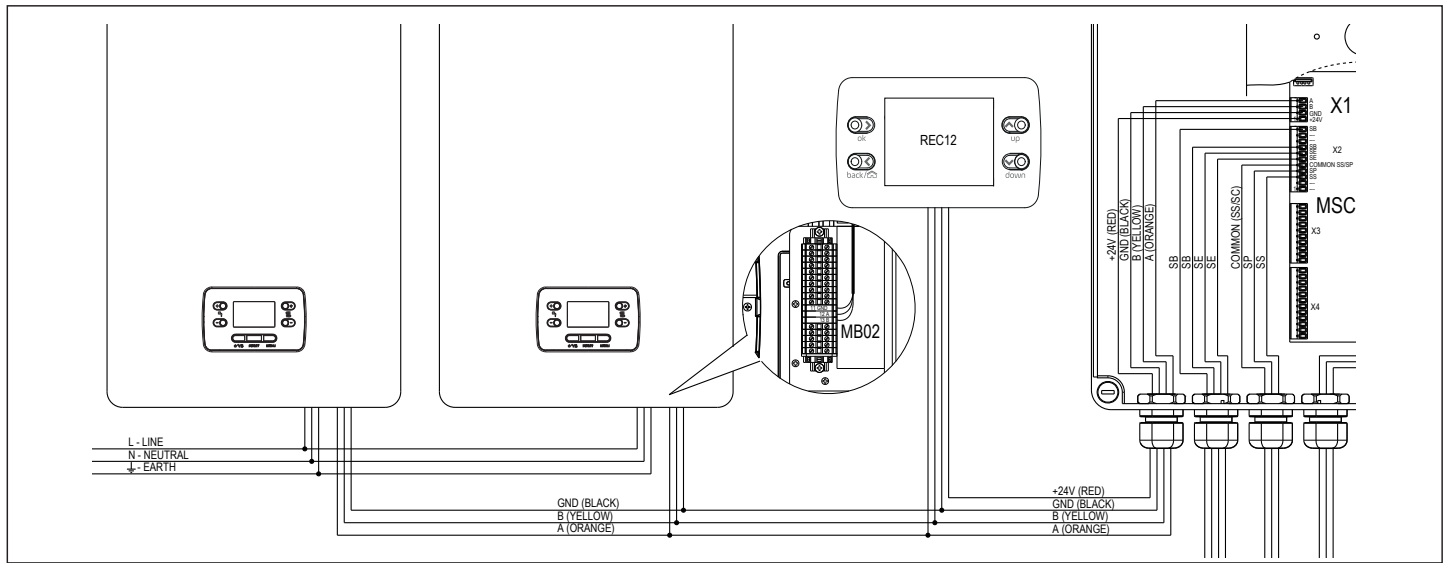

1.14 Accessing the parameters

Press the MENU button for at least 2 seconds to access menu **P1**, where you can program the parameters. The first item of the menu will appear on the display.



Access to parameter programming of the TECHNICAL menu is protected by a password; by pressing MENU again for at least 2 seconds, the letters PWD will flash for 2 seconds (0.5 sec ON and 0.5 sec OFF).

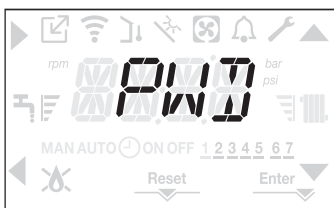

The 4-digit area will now show <<0000>> flashing (0.5 sec ON and 0.5 sec OFF). The ▲, ▼, ► and ◀ icons light up so you can enter the password.

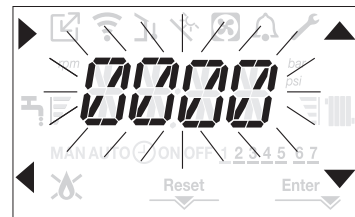

There are two parameter access levels:

INSTALLER SERVICE

(user level requires no password).

Use the buttons next to the ▲▼ arrows to enter the password supplied by the manufacturer for the required access level.

Press button **A** next to the ► arrow to confirm.

By pressing button **B** next to the ◀ arrow, you can quit menu **P1** and return to the previous level.

It is now possible to navigate the menu using the arrow buttons **C** and **D**, confirming access to a sub-menu with the arrow button **A** or by returning to the previous level using the arrow button **B**.

Press and hold (>2 sec) the ◀ button at any point if you want to stop navigating and return to the main screen.

The interface automatically returns to the main screen if no buttons are pressed for 60 seconds.

2 INSTALLATION

2.1 Consignment of the appliance

The **POWER EVO-X** boiler is delivered on a pallet, packaged and protected with cardboard.

The following material can be found in a plastic bag inside the package (1 - page 5):

- Installation booklet and user booklet
- Sheet with the warranty conditions
- Boiler support crossbar
- Pack of 2 screws + 2 dowels for the crossbar
- Angle gas tap
- Flexible condensate discharge hose
- Vent valve connection tube
- Hydraulic test certificate
- Energy Efficiency Label (for models <68kW).

2.2 Dimensions and weights

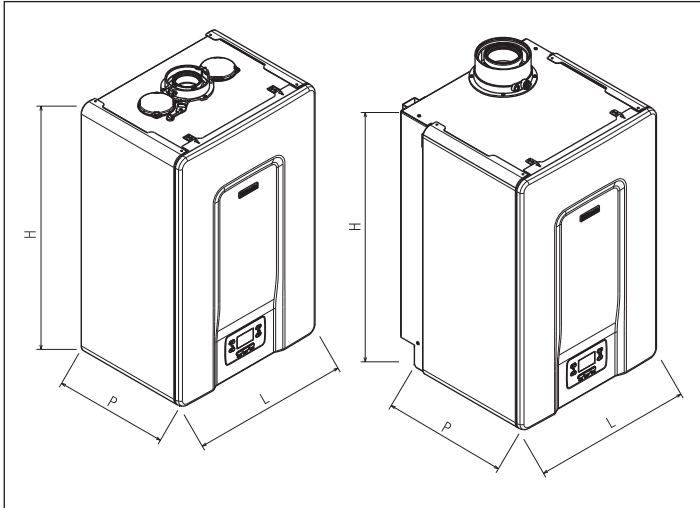

Description	POWER EVO-X				
	50 DEP	50	65	80	
L	470	470	470	470	mm
P	350	350	443	443	mm
H	740	740	740	740	mm
Net weight	35	35	53,5	53,5	kg

2.3 Installation room

The **POWER EVO-X** boiler can be installed in permanently ventilated rooms that have suitably sized ventilation openings complying with the Technical Standards and Regulations applicable to the installation site.

- ⚠ Consider the spaces needed to access the safety and adjustment devices, and to carry out maintenance.
- ⚠ Check that the electric protection level of the appliance is suitable for the characteristics of the room where it is installed.
- ⚠ Make sure the combustion air is not contaminated by substances containing chlorine and fluorine (substances contained, for example, in spray cans, colours and detergents).
- ⚠ The thermal modules may only be installed outdoors if the specific accessory is used.
- ⊘ It is forbidden to cover or reduce the size of the ventilation openings in the installation room, as they are essential to ensure correct combustion.
- ⊘ It is forbidden to leave flammable containers and substances in the room where the boiler is installed.
- ⚠ The use of protective clothing is recommended during the installation of the boiler, to avoid any risk of personal injury.

Always comply with the local regulations of the fire brigade and gas company, and with any possible municipal regulations.

This type C wall-hung condensing boiler can operate as follows:

CASE A: heating-only, without any external storage tank connected. The boiler does not supply domestic hot water.

CASE B: heating-only, with a thermostatically controlled external storage tank (accessory kit available upon request) connected. With every heat request from the storage tank thermostat, the boiler supplies hot water for the preparation of the domestic hot water.

CASE C: heating-only, with the connection of an external storage tank (accessory kit available upon request) (managed by a temperature probe) for preparing domestic hot water. When connecting a storage tank not supplied by us, make sure the probe has the following characteristics: 10 kOhm at 25°C, B 3435 ±1%.

POSITION

There are two categories, based on the type of installation:
boiler type B23P-B53P: forced open installation, with flue gas discharge pipe and combustion air intake from the installation area. If the boiler is not installed outdoors, an air intake point in the installation area is compulsory;

boiler type C13, C13x; C33, C33x; C43, C43x; C53, C53x; C63, C63x; C83, C83x, C93, C93x: appliance with airtight chamber, with flue gas discharge pipe and combustion air intake from outside. An air intake point in the installation area is not required.

The appliance can be installed indoors (**fig. A**) or outdoors, but in a partially protected place (**fig. B**) where it is not directly exposed to the infiltration of rain, snow or hail.

It can work in a temperature range from >0°C to +60°C.

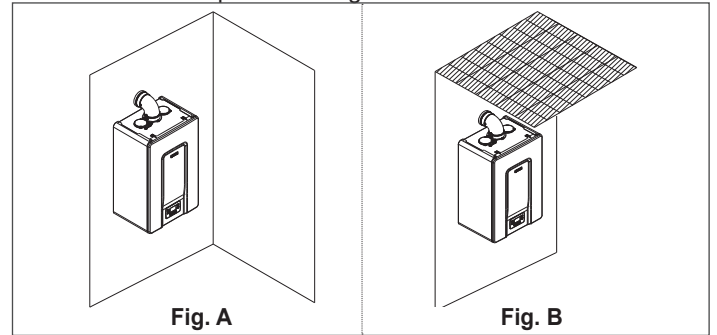

ANTI-FREEZE SYSTEM

The boiler is fitted as standard with an automatic anti-freeze system that activates when the temperature of the water in the primary circuit falls below 5°C. This system is always active, and guarantees protection for the boiler with an air temperature in the installation area of >0°C.

- ⚠ **To take advantage of this protection (based on burner operation), the boiler must be able to switch itself on; any lockout condition (e.g. due to a lack of gas or electricity, or the intervention of a safety device) therefore deactivates the protection.**

If the machine is left without power for long periods in areas where temperatures may fall below 0°C, and you do not want to drain the heating system, you are advised to add a good quality anti-freeze liquid to the primary circuit to protect the machine from any risk of freezing. Carefully follow the manufacturer's instructions with regards not only the percentage of anti-freeze liquid to be used for the minimum temperature at which you want to keep the machine circuit, but also the duration and disposal of the liquid itself.

The boiler components are made of materials resistant to anti-freeze liquids containing ethylene glycol.

MINIMUM CLEARANCES

Access the inside of the boiler for routine maintenance tasks, respecting the minimum installation clearances.

When positioning the appliance, bear in mind that:

- it must be installed on a wall that can support its weight
- it must not be positioned above a cooker or any other cooking device
- it is forbidden to leave inflammable products in the room where the boiler is installed
- heat-sensitive walls (e.g. wooden walls) must be protected with good insulation.

2.4 Minimum clearance areas recommended

Clearances for the assembly and maintenance of the appliance are shown in the figure.

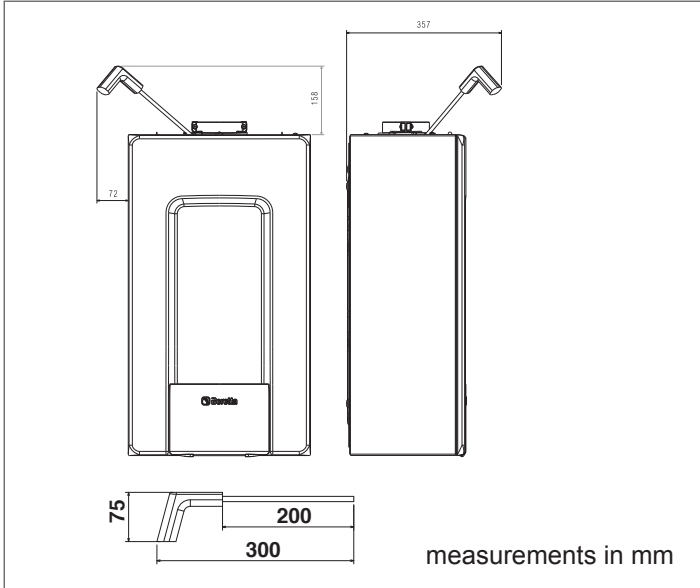
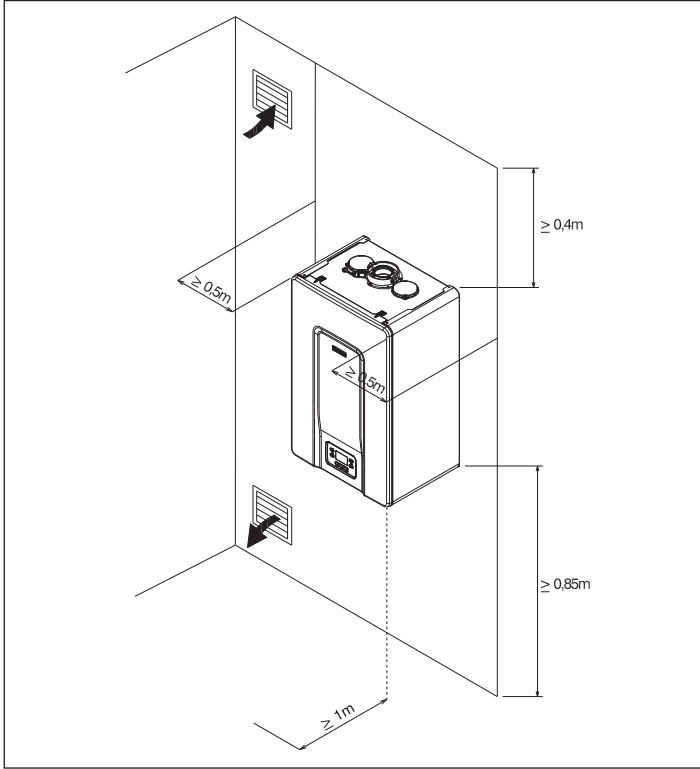

⚠ When installing **POWER EVO-X 50 DEP - 50** models, it is ESSENTIAL to consider the clearance required for the use of the combustion analysis tool. The drawing above shows a situation where the distances between the boiler and wall unit/recess were defined by taking into consideration an instrument with a length of 300 mm. Longer instruments require more space.

2.5 Instructions for the condensate discharge connection

This appliance is designed to prevent the leakage of gaseous combustion products via the condensate discharge pipe, thanks to a special drain-trap located inside it.

All the components of the condensate drainage system must be correctly serviced as per the manufacturer's indications, and must not be modified in any way.

The condensate drain outlet system downstream from the appliance must be made in accordance with the relevant legislation and regulations in force; this is the responsibility of the installer. The system must be sized and installed so as to ensure the correct evacuation of the condensate produced by the appliance and/or collected by the flue gas evacuation systems. All the system components must be made to the highest standards, using materials able to withstand the long-term mechanical, thermal and chemical stress created by the condensate.

Note: if the condensate drain outlet system is exposed to the risk of freezing temperatures, always ensure a suitable level of pipe insulation and consider increasing the diameter of the pipe itself.

The pipe must slope sufficiently to prevent the condensate from stagnating and guarantee it is correctly drained off. There must be an examinable disconnection between the condensate drain outlet pipe of the appliance and the condensate drain outlet system.

2.6 Condensate neutralisation

Standard UNI 11528 makes condensate neutralisation compulsory for systems with a total output of over 200 kW. For systems with an output between 35 and 200 kW, neutralisation may or may not be compulsory depending on the number of flats (for residential applications) or the number of occupants (for non-residential applications) served by the system.

2.7 Installation on appliances that are old or that need to be updated

When the thermal units are installed on old systems or those requiring modernisation, check that:

- The flue is suitable for the temperature of the flue gases, calculated and built according to the standard, as straight as possible, airtight, insulated, and has no blockages or constrictions. Refer to paragraph "2.13 Flue gas exhaust and combustion air suction" for further information
- The electrical system is installed by qualified personnel and complies with the specific standards
- The fuel supply line (and tank, if installed) respect the specific standards
- The expansion vessel ensures the total absorption of the expansion of the fluid in the system
- The flow rate, discharge head and flow direction of the circulation pumps are correct
- The system has been washed to remove sludge and encrustations, and the seals have been checked
- A treatment system is fitted when the values of the supply/make-up water are different from those indicated in the "2.14 Filling the heating system and eliminating air" paragraph.

⊖ The manufacturer is not liable for any damage resulting from the incorrect construction of the flue gas exhaust system.

Handling and removing the packaging

- ⚠ Do not remove the cardboard packaging until the place of installation has been reached.
- ⚠ Before transporting and removing the package, put on protective clothing (PPE) and make sure you have the right equipment and tools for the size and weight of the appliance.
- ⚠ This operation must be carried out by several people, using equipment suitable for the size and weight of the appliance. Make sure the load does not become unbalanced during handling.

To remove the packaging, proceed as follows:

- Remove the box.
- Remove the front protective element (1).
- Remove the upper and lower protective elements (2).
- Remove the side protective elements (3).
- Pull off the protective bag.

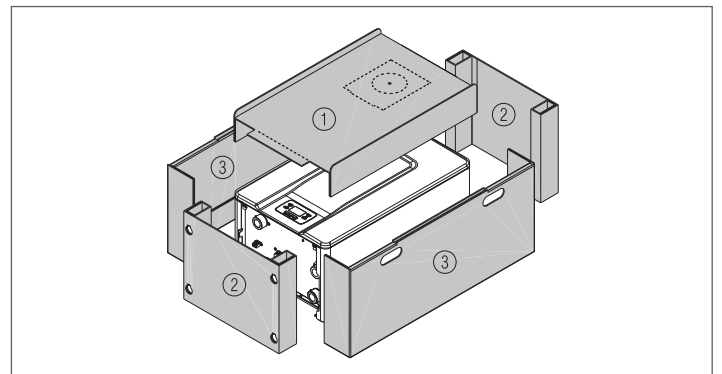

2.8 Assembling the boiler

⚠ The **POWER EVO-X** thermal modules are supplied with a bracket for wall-mounting.

⚠ Check that the wall on which the appliance is to be installed is sufficiently solid and guarantees the safe anchorage of the screws.

For the assembly, proceed as follows:

- position the boiler support plate (F) on the wall and use a spirit level to make sure it is perfectly horizontal
- mark the position of the holes (Ø 6 mm) for securing the boiler support plate (F)
- make sure all the measurements are exact, then drill the holes using drill tips with the diameters indicated above
- fasten the plate to the wall.

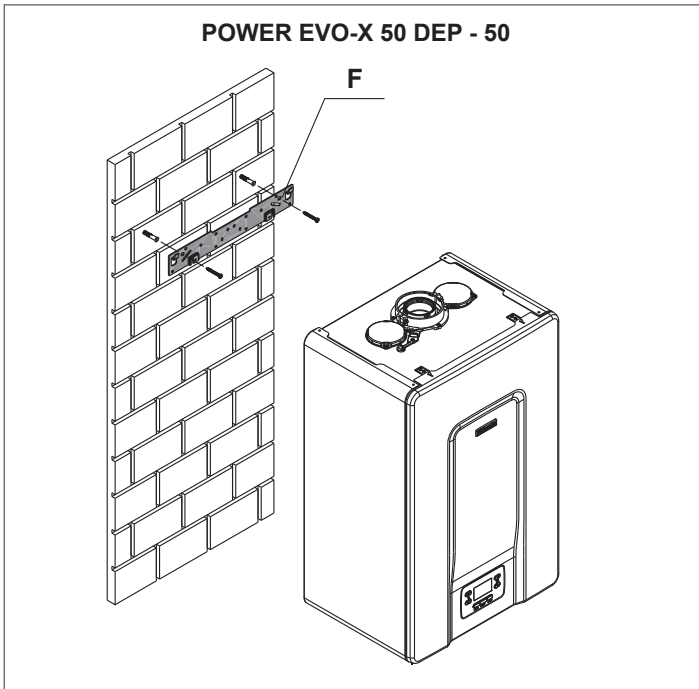

POWER EVO-X 65 - 80

To ensure the boiler is firmly fastened to the wall, replace the screws on the back of the boiler with the longer ones contained in the bag supplied with the appliance.

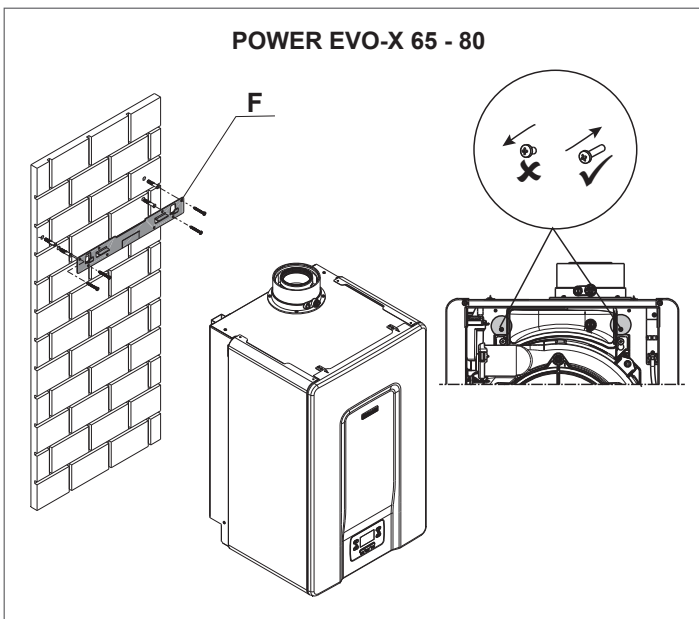

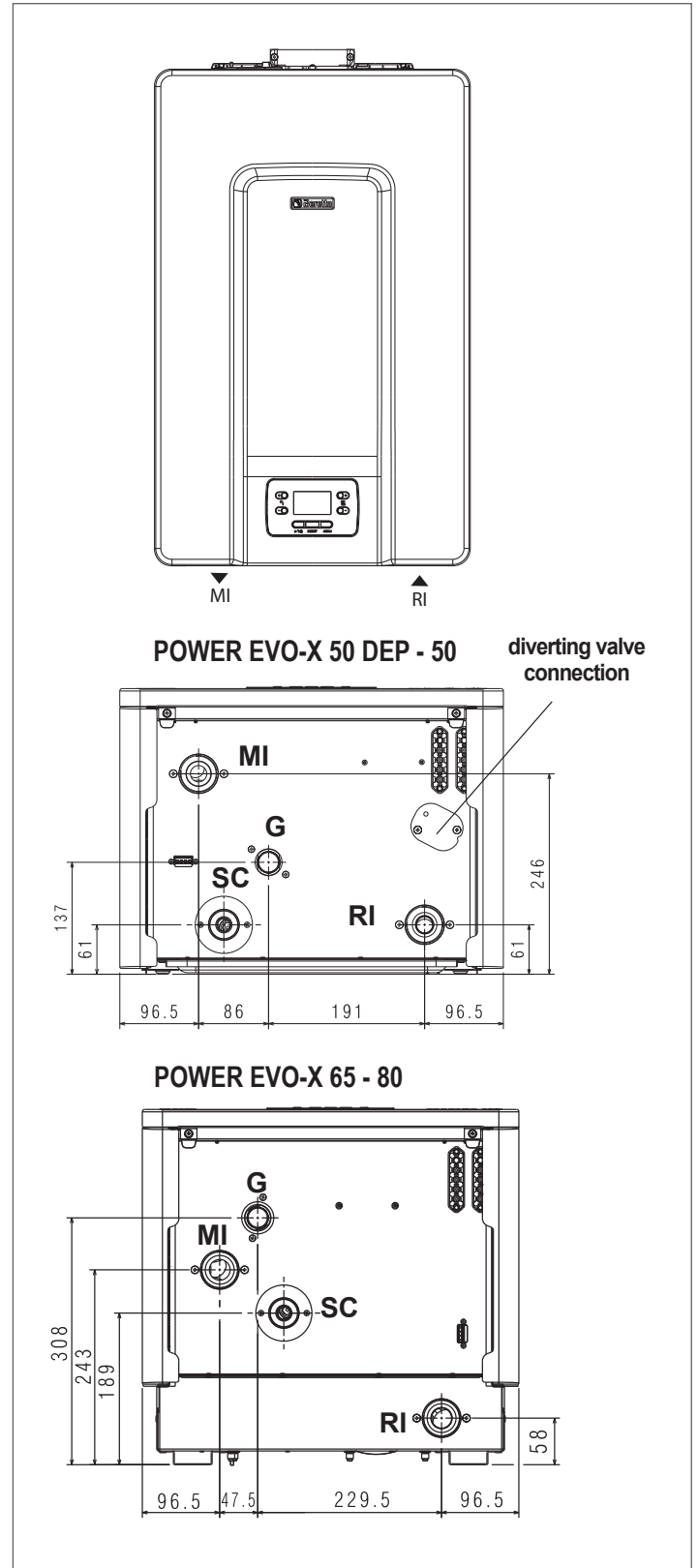

⚠ Before making the hydraulic connections, the protection plugs must be removed from the delivery, return and condensate drain piping.

The dimensions and positioning of the thermal module water fittings are shown in the table below.



DESCRIPTION	POWER EVO-X				
	50 DEP	50	65	80	
MI (system delivery)	G 1" 1/2 M	G 1" 1/2 M	G 1" 1/2 M	G 1" 1/2 M	Ø
RI (system return)	G 1" 1/2 M	G 1" 1/2 M	G 1" 1/2 M	G 1" 1/2 M	Ø
SC (condensate discharge)	25	25	25	25	Ø mm
G (gas inlet)	G 3/4" M	G 3/4" M	G 3/4" M	G 3/4" M	Ø
diverter valve connection	G 1" 1/2 M	G 1" 1/2 M	-	-	Ø

		
TIGHTENING TORQUE	Ø 3/4"	35Nm
	Ø 1/2"	25Nm

 Before connecting the boiler, the protection plugs must be removed from the delivery, return and condensate discharge pipes.

 Before connecting the boiler, the system must be cleaned. This step is vital when a replacement is being made on a pre-existing system.

If the old generator is still installed in the system, when cleaning you are advised to:

- add a de-scaling additive
- operate the system with the generator activated for approx. 7 days
- discharge dirty system water and flush the system out at least once with clean water

Repeat the last step if the system is very dirty.

If the system is new or if the old generator is not fitted or available, use a pump to circulate the water with the additive within the system for approx. 10 days, and then carry out the final washing procedure as described in the previous point.

Once the cleaning operations have been completed, it is advisable to add a suitable protective liquid to the systems water before installing the boiler.

To clean the internal water circuit of the heat exchanger, contact the Aftersales Service.

 Do not use incompatible liquid detergents, including acids (for instance hydrochloric acid and similar) in any concentration.

 Do not subject the heat exchanger to cyclical pressure changes because fatigue stress is very dangerous for the system components.

2.9 Schematic hydraulic systems

Layout 1: circuit with boiler directly connected to heating system (check that the pump discharge head is sufficient to ensure adequate circulation)

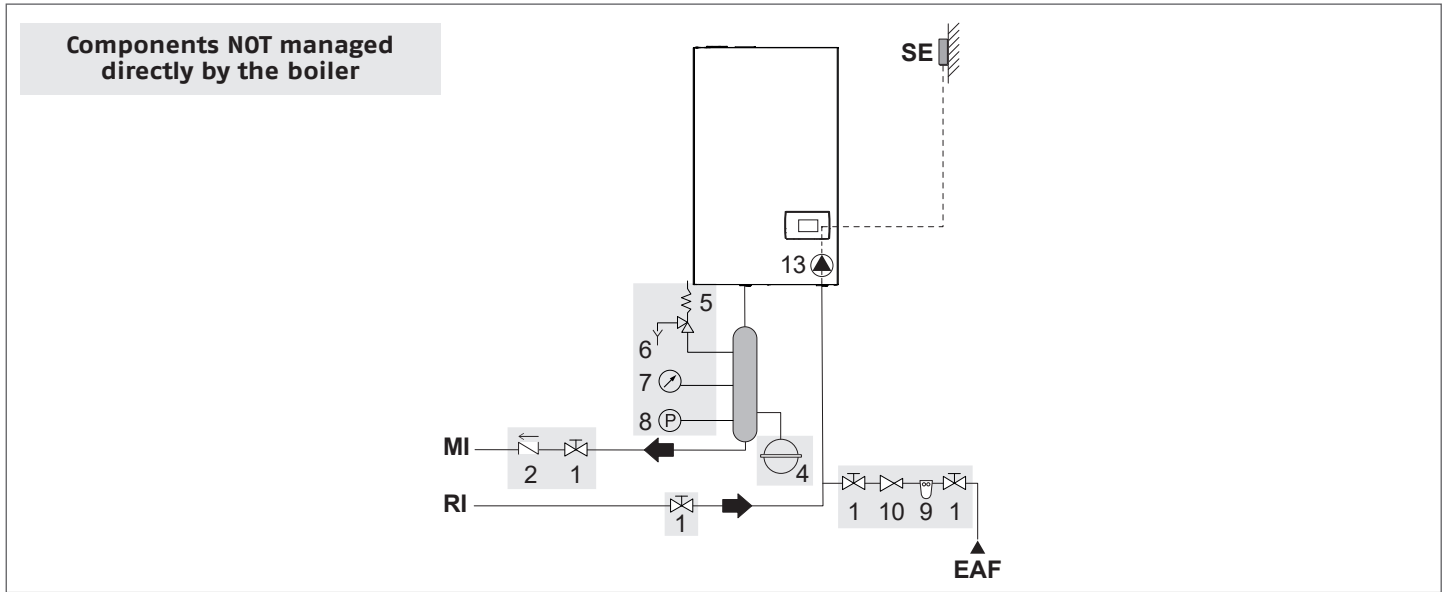

Layout 2: circuit with boiler directly connected to heating system and DHW tank (check that the pump discharge head is sufficient to ensure adequate circulation)

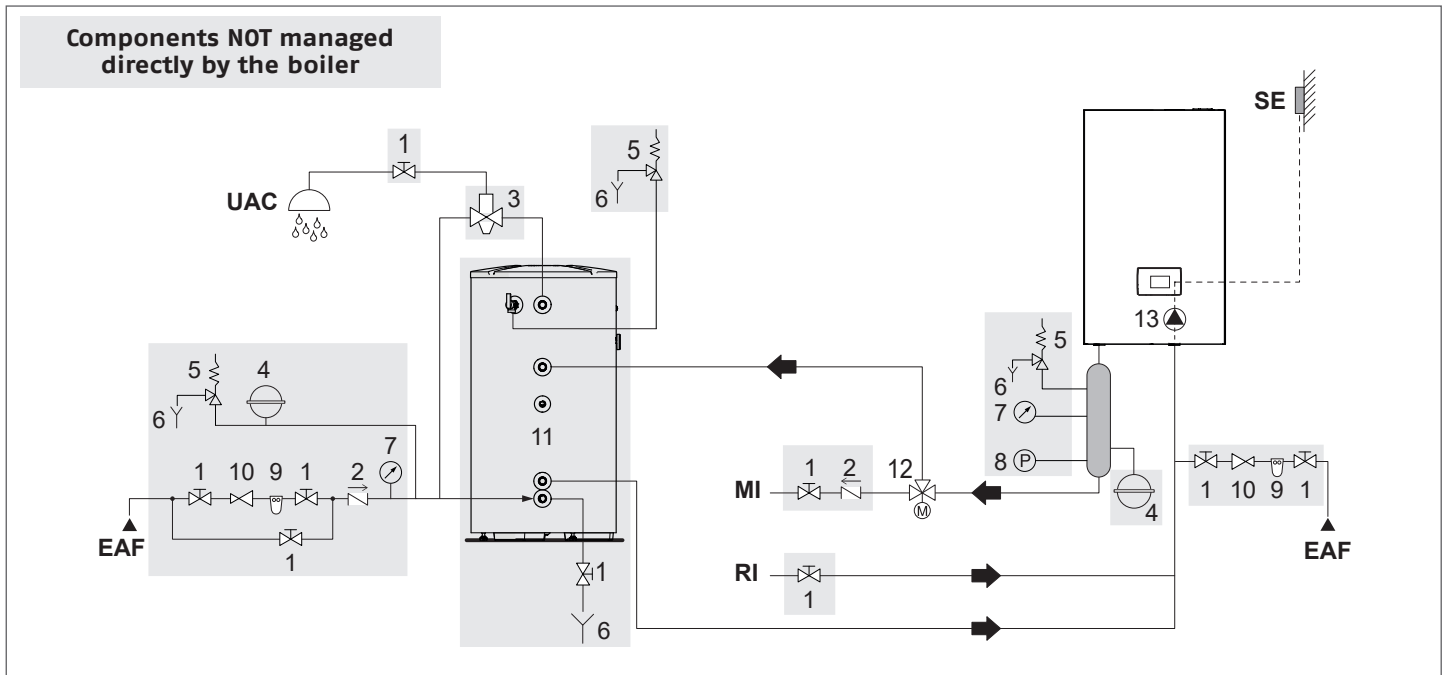

1	Disconnecter valve
2	Non-return valve
3	Anti-burn mixer valve
4	Expansion vessel
5	Safety valve
6	Discharge
7	Pressure gauge
8	Minimum pressure switch
9	Softener filter
10	Pressure reducer
11	Storage tank
12	Diverting valve
13	Boiler circulator
SE	Outdoor temperature sensor
MI	High-temperature system delivery
RI	High-temperature system return
EAF	Cold water inlet
UAC	DHW outlet

⚠ The DHW and heating circuits must be completed with expansion vessels of adequate capacity and correctly-sized safety valves. The discharge of the safety valves and appliances must be connected to a suitable collection and disposal system (see the price list catalogue for compatible accessories).

⚠ The selection and installation of the system components is the responsibility of the installer, who must respect the standards of good practice and current legislation.

⚠ Special supply/make-up water must be conditioned using suitable treatment systems.

⊖ It is forbidden to operate the boiler and circulators without water.

⚠ **On POWER EVO-X 50 DEP - 50 models, the diverting valve (12) can be installed in the boiler.**

Layout 3: circuit with boiler connected to heating system via separator

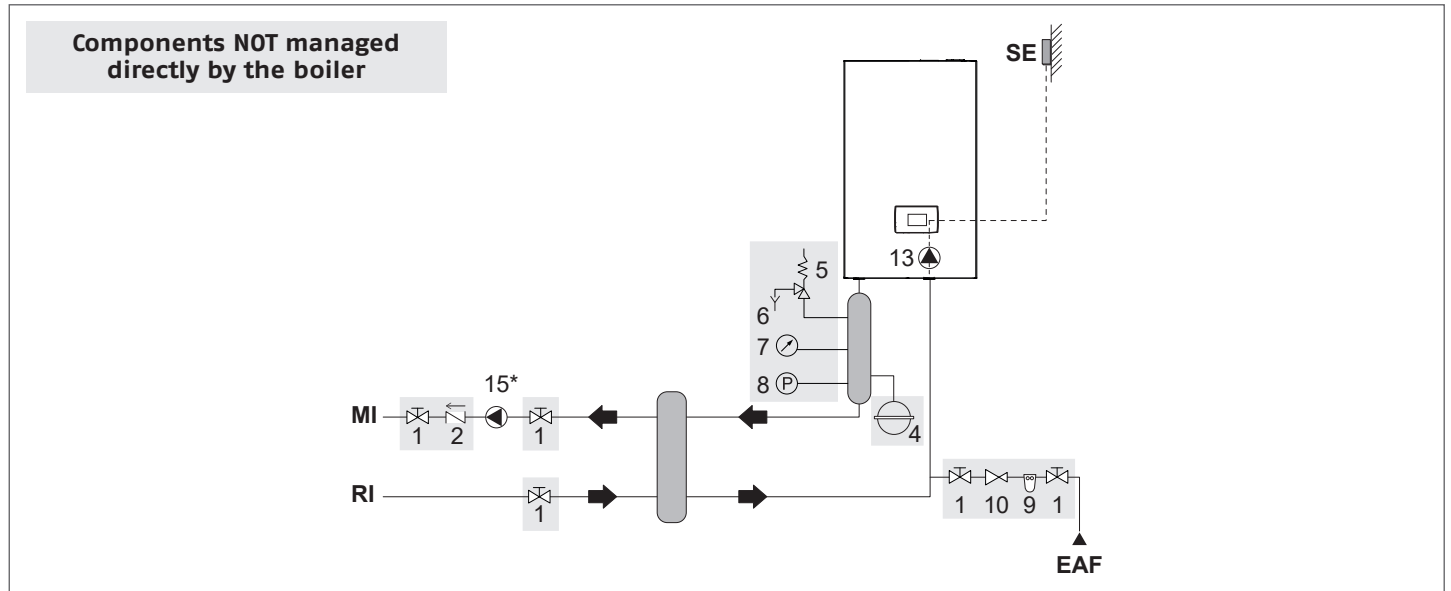

Layout 4: circuit with boiler connected to DHW tank and heating system via separator

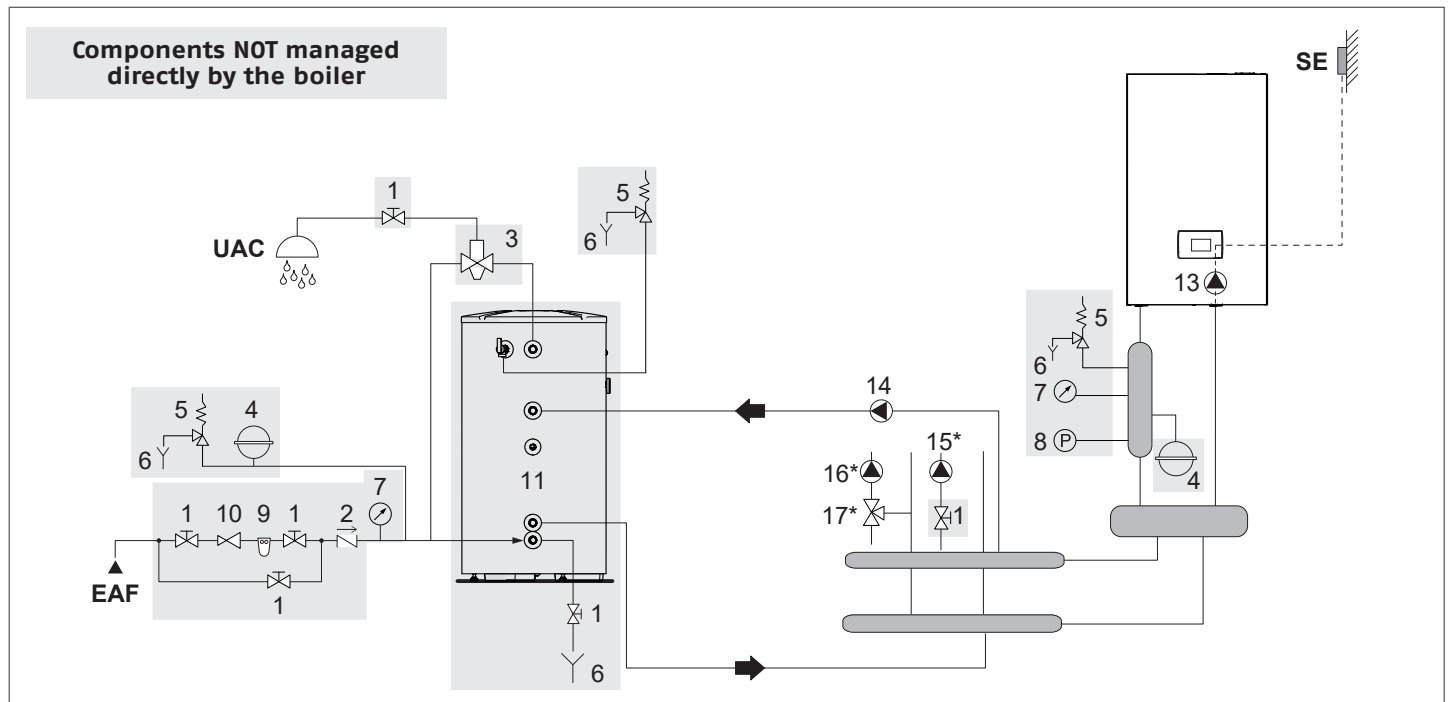

1	Disconnecter valve
2	Non-return valve
3	Anti-burn mixer valve
4	Expansion vessel
5	Safety valve
6	Discharge
7	Pressure gauge
8	Minimum pressure switch
9	Softener filter
10	Pressure reducer
11	Storage tank
13	Boiler circulator
14	Storage tank circulator
15	Direct zone circulator (*managed by boiler with specific accessory)
16	Mixed zone circulator (*managed by boiler with specific accessory)
17	Mixing valve (*managed by boiler with specific accessory)
SE	Outdoor temperature sensor
MI	High-temperature system delivery
RI	High-temperature system return
EAF	Cold water inlet
UAC	DHW outlet

- ⚠ The domestic hot water and central heating circuits must be completed with expansion vessels of adequate capacity and suitable, correctly-sized safety valves. The discharge of the safety valves and appliances must be connected to a suitable collection and disposal system (see the price list catalogue for compatible accessories).
- ⚠ The selection and installation of the system components is the responsibility of the installer, who must respect the standards of good practice and current legislation.
- ⚠ Special supply/make-up water must be conditioned using suitable treatment systems.
- ⊖ It is forbidden to operate the boiler and circulators without water.

Layout 5: circuit with boiler connected to heating system and DHW tank via separator

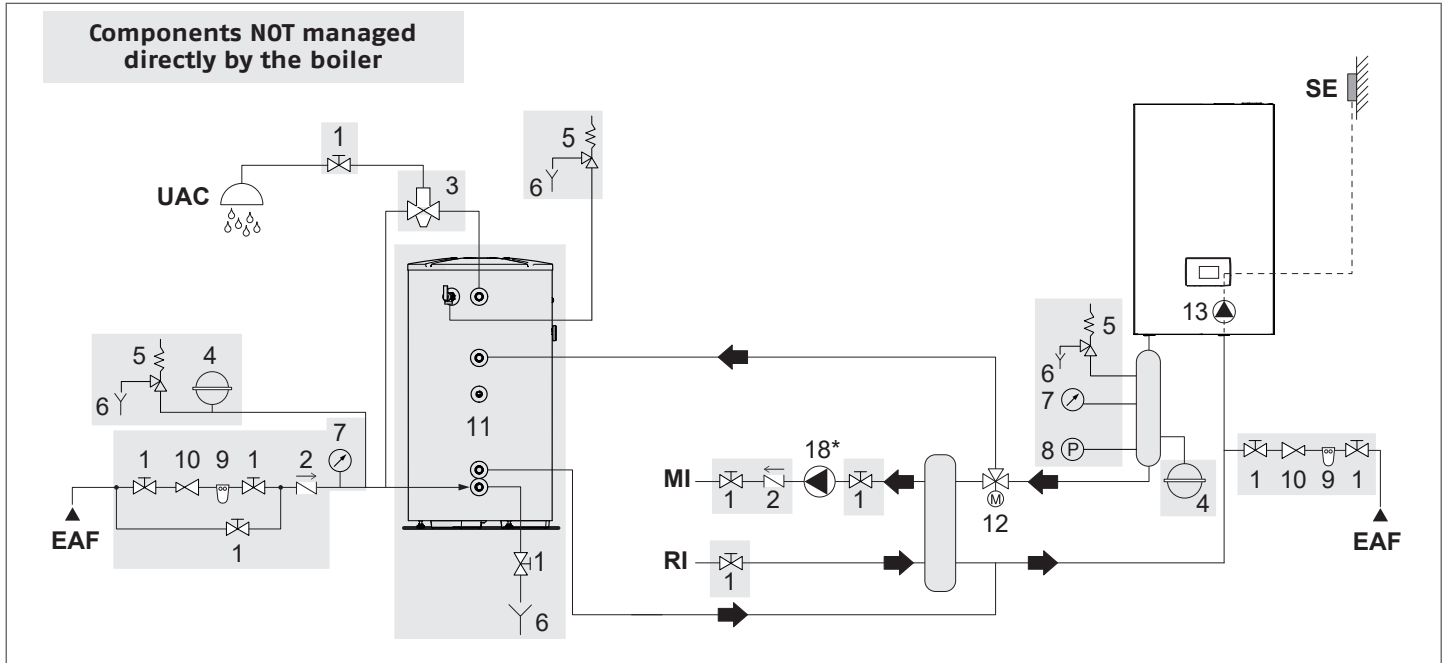

1	Disconnecter valve
2	Non-return valve
3	Anti-burn mixer valve
4	Expansion vessel
5	Safety valve
6	Discharge
7	Pressure gauge
8	Minimum pressure switch
9	Softener filter
10	Pressure reducer
11	Storage tank
12	Diverting valve
13	Boiler circulator
18	High-temperature system circulator (*managed by boiler with specific accessory)
SE	Outdoor temperature sensor
MI	High-temperature system delivery
RI	High-temperature system return
EAF	Cold water inlet
UAC	DHW outlet

- ⚠ The domestic hot water and central heating circuits must be completed with expansion vessels of adequate capacity and suitable, correctly-sized safety valves. The discharge of the safety valves and appliances must be connected to a suitable collection and disposal system (see the price list catalogue for compatible accessories).
- ⚠ The selection and installation of the system components is the responsibility of the installer, who must respect the standards of good practice and current legislation.
- ⚠ Special supply/make-up water must be conditioned using suitable treatment systems.
- ⊘ It is forbidden to operate the boiler and circulators without water.
- ⚠ **On POWER EVO-X 50 DEP - 50 models, the diverting valve (12) can be installed in the boiler.**

2.10 Removing the casing

To access the internal components, remove the casing as explained below:

- locate and loosen the 2 screws (**A**) fixing the casing to the boiler, levering the fixing clips (**C**) and detaching the lower part of the casing
- raise the casing to release it from the upper tabs (**B**), then remove it.

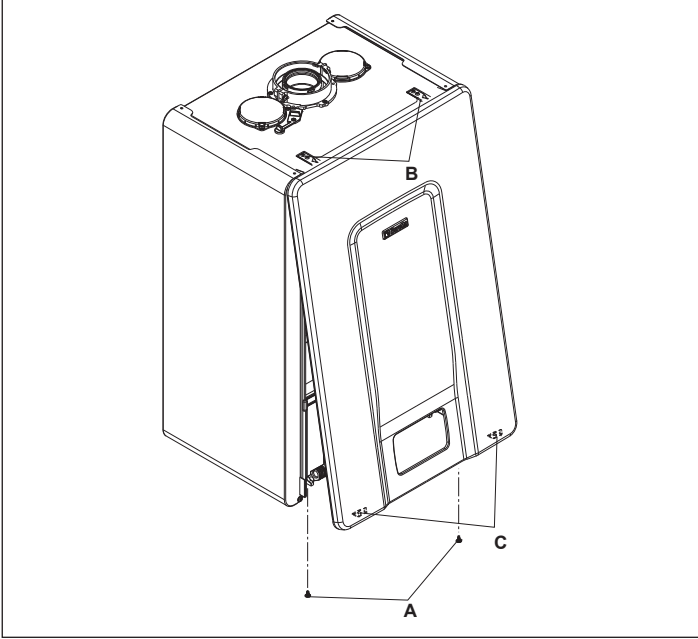

- ⚠ If the side panels are removed, refit them in their initial position (referring to the label on the panel itself).
- ⚠ If the front panel is damaged, it must be replaced.
- ⚠ The noise-absorbing panels in the front and side walls ensure the airtight seal of the air supply duct in relation to the place of installation.
- ⚠ It is therefore **CRUCIAL** to reposition the components correctly to ensure the boiler seal.

2.11 Gas connections

The gas connection must be made respecting the installation regulations in force, and sized to ensure the correct gas delivery to the burner.

Before making the connection, check that:

- ⚠ The gas type is suitable for the appliance
- ⚠ If the appliance needs to be adapted for use with another gaseous fuel, contact your local Aftersales Service to have the necessary modifications made. These operations must not be carried out by the installer under any circumstances.
- ⚠ The piping is thoroughly clean
- ⚠ The gas meter flow rate is capable of ensuring the simultaneous use of all the appliances connected to it. The appliance connection to the gas supply line must be made in accordance with the current regulations.
- ⚠ The intake pressure with the appliance OFF has the following reference values:
 - powered by methane gas: optimal pressure 20 mbar
 - powered by LPG: optimal pressure 37 mbar
- ⊖ Do not use fuels other than those envisaged, for any reason whatsoever.

While it is normal for the intake pressure to decrease while the appliance is operating, it is a good idea to check that there are no excessive pressure fluctuations. In order to limit the extent of these variations, the diameter of the gas supply line must be defined according to the length and the pressure drops of the line itself, from the meter to the boiler.

- ⚠ If fluctuations in the gas distribution pressure are encountered, you are advised to install a pressure stabiliser upstream of the appliance's gas inlet. For G31 gas supply, all the necessary precautions must be taken to prevent the fuel gas from freezing in the event of extremely low outdoor temperatures.

If the gas distribution network contains solid particles, install a filter on the fuel supply line. When selecting it, bear in mind that pressure drops due to the filter should be as low as possible.

- ⚠ Once the installation is complete, check that the joints are perfectly sealed.

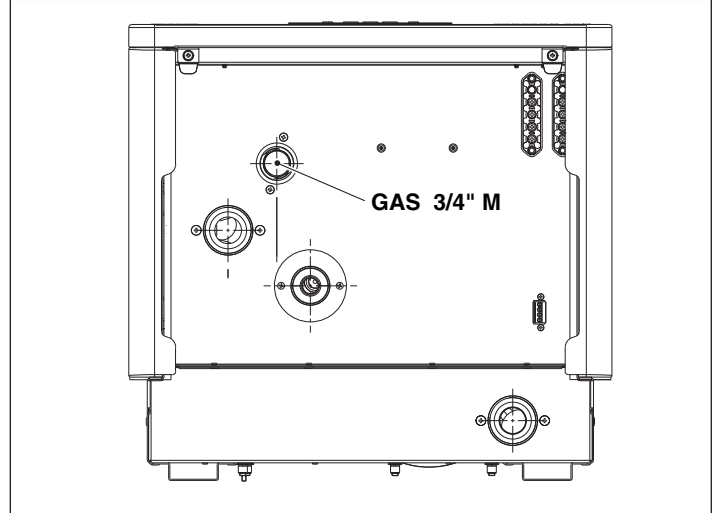

2.12 Electrical wiring

The **POWER EVO-X** thermal module leaves the factory fully wired, and only needs to be connected to the main power supply and the system components.

- ⚠ It is mandatory:
 - to use an omnipolar magnetothermal switch, a line disconnect, complying with CEI-EN standards (contact opening of at least 3mm)
 - to refer to the wiring diagrams in this booklet when connecting the system components and carrying out any electrical task.
- ⚠ The use of adaptors, multiple sockets and extensions to power the appliance is not allowed.
- ⚠ Any work on the electrical system must only be carried out by qualified personnel in compliance with all legal provisions, paying special attention to the safety regulations.
- ⚠ The supply cable is not supplied as standard. The connection to the mains supply must be made using FROR 3G1.5 type cables (standardised by CEI 20-27) or the equivalent.
- ⚠ Secure the cables with ties to ensure they are correctly positioned inside the appliance.
- ⚠ It is vital that the electricity cables and those for the low voltage system components (room/heating request thermostat, outdoor temperature sensors, etc.) are separated.
- ⚠ The installer is responsible for ensuring the appliance is suitably earthed; the manufacturer will not be liable for any damage resulting from an incorrect or absent earth connection.
- ⚠ The length of the wires between the cable fixing point and the terminals must be such that, if the cable slips out of its fixing point, the live wires are pulled taut prior to the earthing one. For this reason, the earthing wire must be at least 2 cm longer than the others.
- ⚠ The boiler can work with a phase-neutral or phase-phase supply.

- ⚠ It is also advisable to respect the phase-neutral connection (L-N).
- ⚠ Before connecting any external electrical components (regulators, electric valves, climate control probes, etc.) to the appliance, make sure their electrical characteristics (voltage, absorption, acceleration current) are compatible with the available inputs and outputs.
- ⚠ The use of any type of tube for earthing the appliance is forbidden.
- ⊖ It is forbidden to pull, detach or twist any electric cables from the thermal module, even when the latter is disconnected from the mains supply.

Low voltage connections

Make the low voltage connections as follows:

- use the connectors supplied:
 - ModBus 4-pole connector for the BUS 485 signal (- A B +)

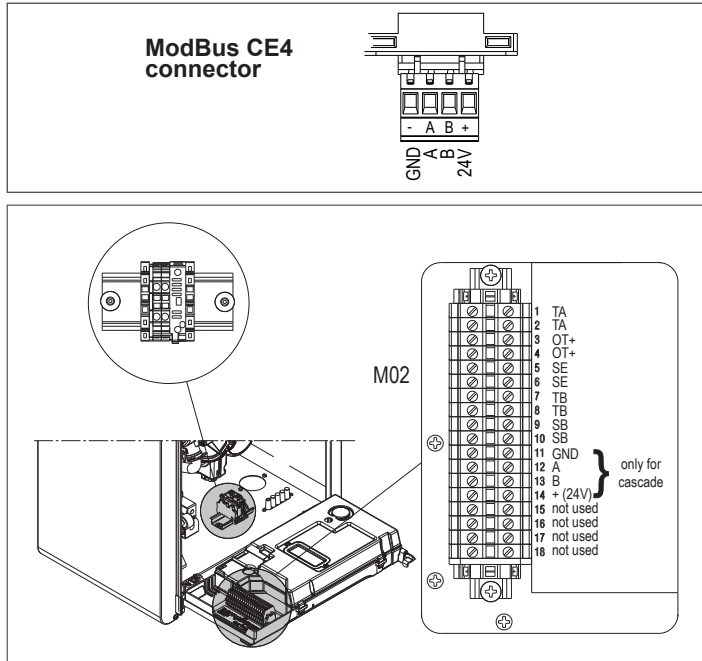

CE4	(- A B +)	Bus 485
M02	TA	Room thermostat (voltage-free contact)
	OT+	Open therm
	SE	Outdoor temperature sensor
	SB	Storage tank probe
	TB	Storage tank thermostat

- make the electrical connections using the required connector, as indicated in the detailed drawing
- after making the connections, insert the connector in its counterpart.

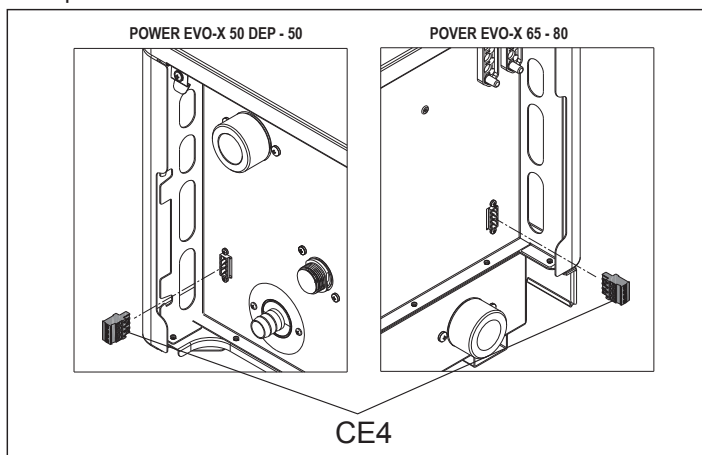

- ⚠ You are advised to use conductors with a section no larger than 0.5 mm².

Connecting the OT+ remote control

NOTE: if an OT+ remote control is connected to the system and parameter P8.03= 1 (SERVICE), the boiler display will appear as follows:

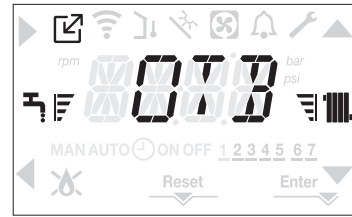

In particular, on the boiler display:

- it is no longer possible to set the boiler OFF/WINTER/SUMMER status (which can now be set via the OT+ remote control)
- it is no longer possible to set the DHW setpoint (which can now be set via the OT+ remote control)
- the DHW setpoint value is shown in the INFO menu
- the heating setpoint set on the boiler display is only used if there are requests from TA but no requests via the OT+ remote control if parameter:
 - P3.11 = 1
 - or
 - P3.11 = 0 and jumper on pin 1-2 of X21 closed
- to activate the COMBUSTION CONTROL function with the OT+ remote control connected, it is necessary to temporarily disable the connection by setting parameter P8.03 = 0 (remember to reset the value of this parameter after using the function).

Note that it is not possible, with the OT+ remote control connected, to change the value of parameters P4.12 to P4.23 from 0 to 1.

Note: the connection of an OT+ remote control is not permitted if the system already contains BE16 interface boards. For the same reason, BE16 boards cannot be connected if there is already an OT+ device. In this case, the system will give the following error message: <<OTER>>.

Connecting the mains voltage

The connection to the mains supply must be made on the M01 terminal board, as shown in the detailed drawing and in the wiring diagram.

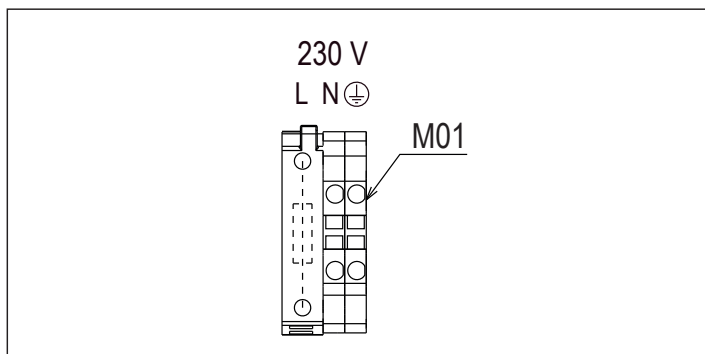

To connect the power supply cable

- remove the casing as explained in paragraph "2.10 Removing the casing"
- rotate the instrument panel

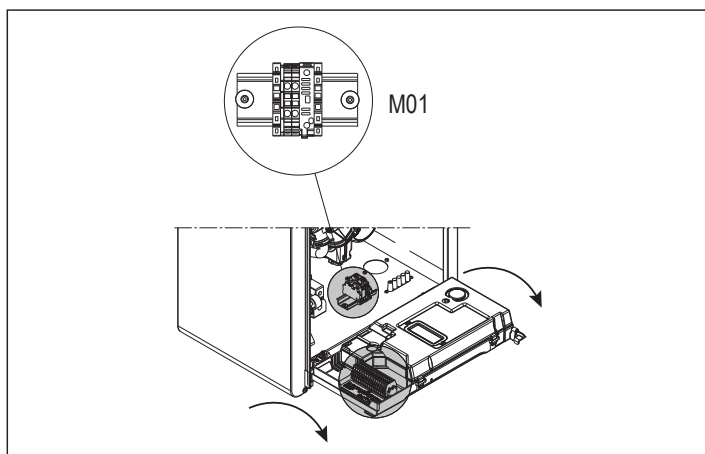

- insert the supply cable (not supplied) in the cable grommet underneath the bracket, then connect it as shown in the figure and fix it in place using the tear-off tie, tightening it firmly.

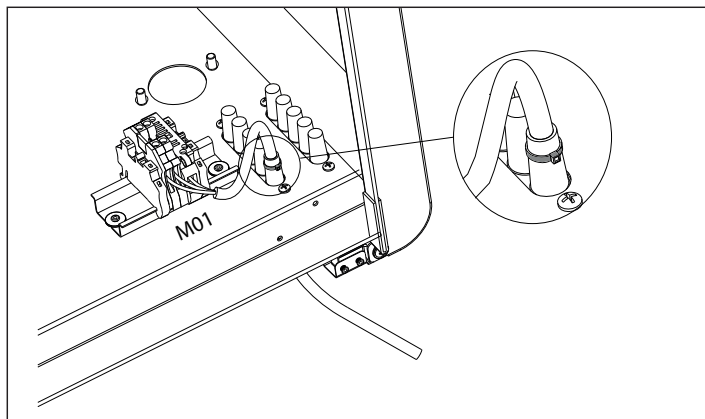

NOTE L-N CONNECTION IS ADVISABLE

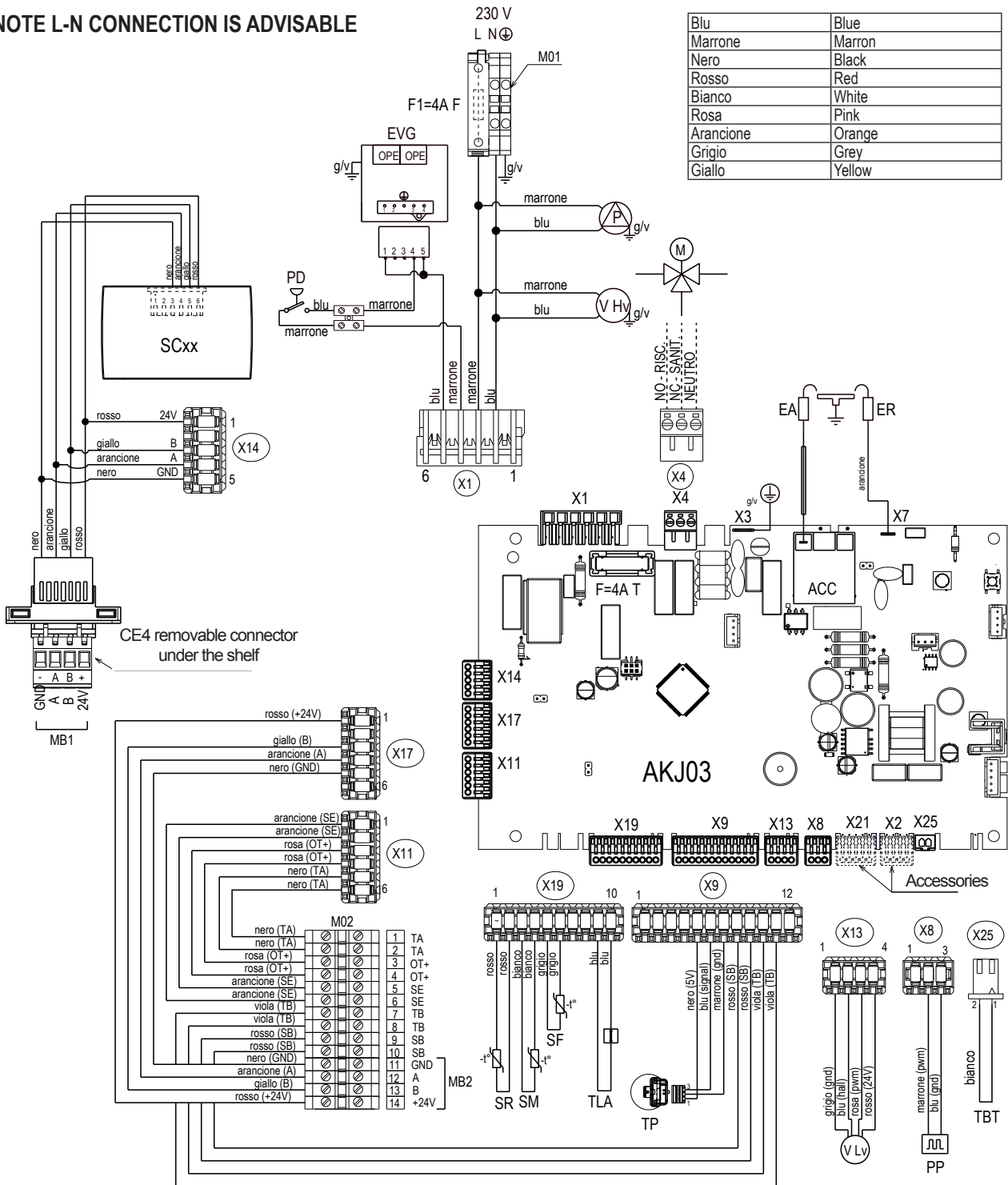

Key

- AKJ03 Control board with built-in ignition transformer
- SC User interface
- F Fuse
- F1 External fuse 4A F
- X Connection fittings
- ACC Ignition transformer
- EA Ignition electrode
- ER Detection electrode
- V Hv 230V fan power supply
- P Pump
- PD Differential pressure switch
- PP PWM signal for pump command
- V Lv PWM signal for fan command
- TP Pressure transducer
- SR Return probe
- SM Flow probe
- TLA Safety thermostat
- SF Flue gas probe

- EVG Gas valve
- M 3-way valve
- M01 Power supply terminal board (high voltage)
- M02 Terminal board for connection of external services (low voltage)
- MB1 Modbus 1: commands/wi-fi key
- MB2 Modbus 2: cascades
- SB Storage cylinder probe
- TB Storage tank thermostat
- TA Room thermostat
- OT+ Open Therm
- SE Outdoor temperature sensor
- CE4 Modbus 1 connector
- X4 Connection for hydraulic 3-way valve (available upon request from the catalogue)
- X2 Remote alarm (accessory)
- X21 Zone valve or additional pump (accessory)

2.13 Flue gas exhaust and combustion air suction

To evacuate the combustion products, refer to UNI 7129-7131. Always comply with the local regulations of the fire brigade and gas company, and with any possible municipal regulations. It is essential for flue gas evacuation and boiler combustion air transfer that only original pipes are used (apart from type C6, as long as it is certified), and that the connection is made as explained in the instructions supplied with the flue gas accessories. A single flue can be connected to several appliances provided that every appliance is the condensing type.

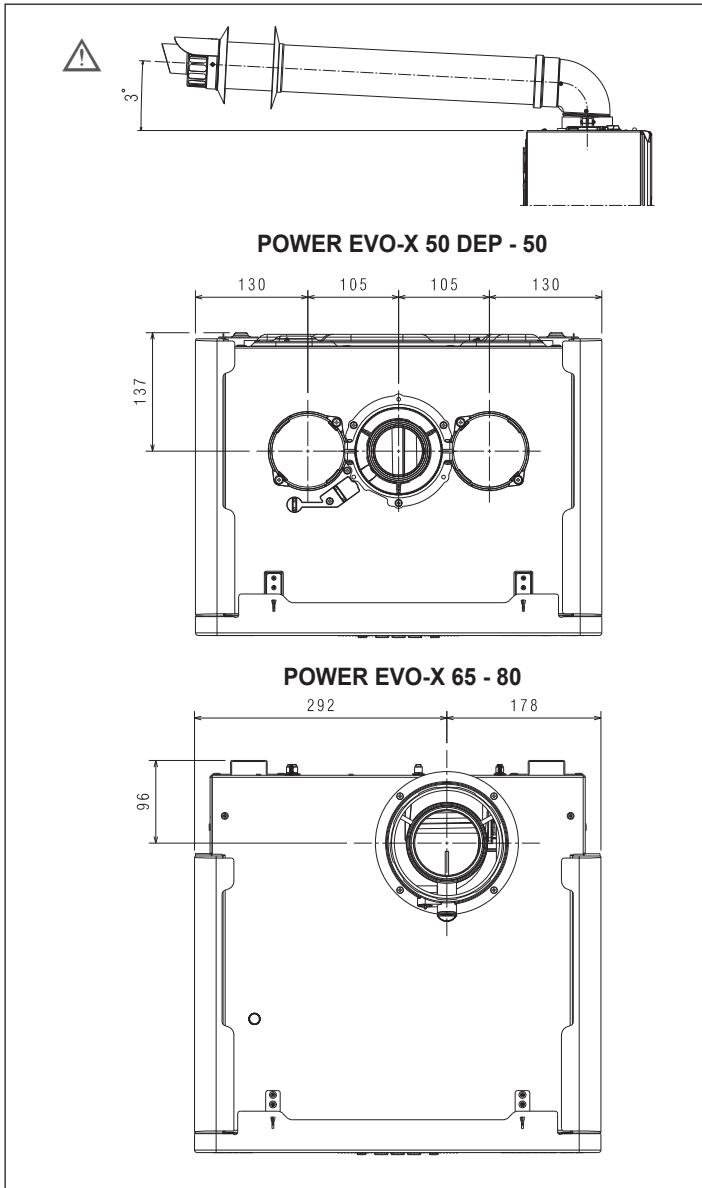

⚠ Do not connect this appliance's flue gas extraction pipes with those of other appliances, unless this is specifically authorised by the manufacturer. Non-compliance with this precaution may cause a build-up of carbon monoxide in the room where the appliance is installed. This could jeopardise people's health and safety.

⚠ For more information on discharge pipes for thermal modules connected in a cascade system, refer to the price list catalogue and the instructions supplied with the relative accessories.

⚠ Make sure the combustion (intake) air is not contaminated by:

- waxes/chlorinated detergents
- chemical products based on swimming pool chlorine
- calcium chloride
- sodium chloride use to soften water
- refrigerant leaks
- paint or varnish removers

- hydrochloric acid/muriatic acid
- cements and glues
- anti-static softeners used in dryers
- chloride used for domestic or industrial applications as detergent, whitener or solvent
- adhesives used to fix construction products etc.

⚠ To prevent contamination of the thermal module, do not install suction line air intakes and flue gas discharge pipes near:

- dry-cleaners/laundry rooms and factories
- swimming pools
- metal processing plants
- beauty parlours
- fridge repair shops
- photo-processing facilities
- body-shops
- plastics manufacturing plants
- furniture construction areas and plants.

⚠ The condensing appliances described in this manual must be installed with flue gas pipes complying with current legislation and purposely designed for this specific use.

⚠ Check that pipes and joints are not damaged.

⚠ Joint seals must be made with materials that can withstand the acidity of the condensate and the temperatures of the flue gases.

⚠ Make sure the pipes are correctly assembled according to the direction of the flue gases and the descent of any possible condensate.

⚠ Inadequate or incorrectly sized flue gas pipes may increase combustion noise, create condensate extraction issues and negatively impact on the combustion parameters.

⚠ Check that pipes are suitably far (min. 500 mm) from flammable or heat-sensitive construction elements.

⚠ Check that no condensate builds up along the pipe. To this end, the pipe should have a gradient of at least 3° degrees towards the appliance if there is a horizontal section. If the horizontal section or the vertical one is more than 4 metre long, a drain-trap for the condensate must be provided at the bottom of the line. The height of the drain-trap must be at least equal to "H" (see figure A page 34). The drain-trap discharge must therefore be connected to the sewerage system.

⊖ It is forbidden to obstruct or choke the flue gas pipe, or the combustion air suction pipe (if installed).

⊖ It is forbidden to use pipes not purposely designed for this function, as the contact with the condensate would quickly damage them.

Installing the flue gas pipes

- Position the discharge pipe so the connection is fully up against the flue gas turret of the boiler.

POWER EVO-X 50 DEP - 50

- Make sure the 4 tabs (A) are inserted in the groove (B).
- Fully tighten the screws (C) that hold the two locking terminals of the flange, so the bend is held against the flange itself.

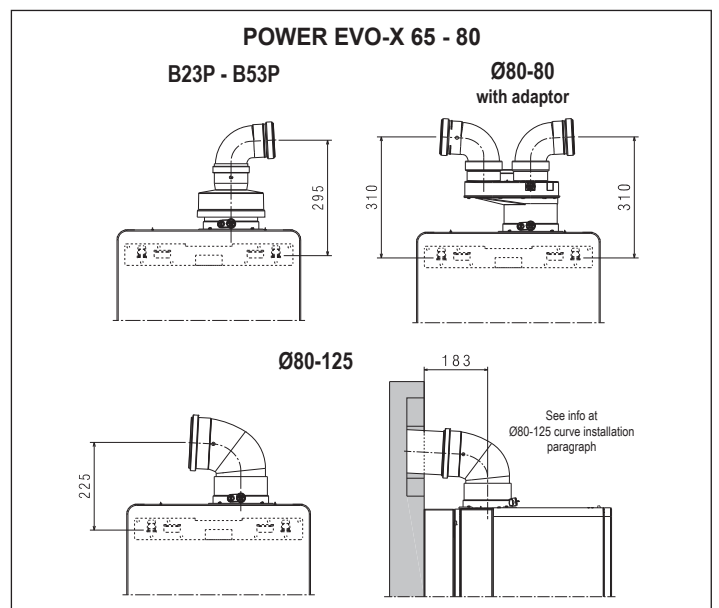
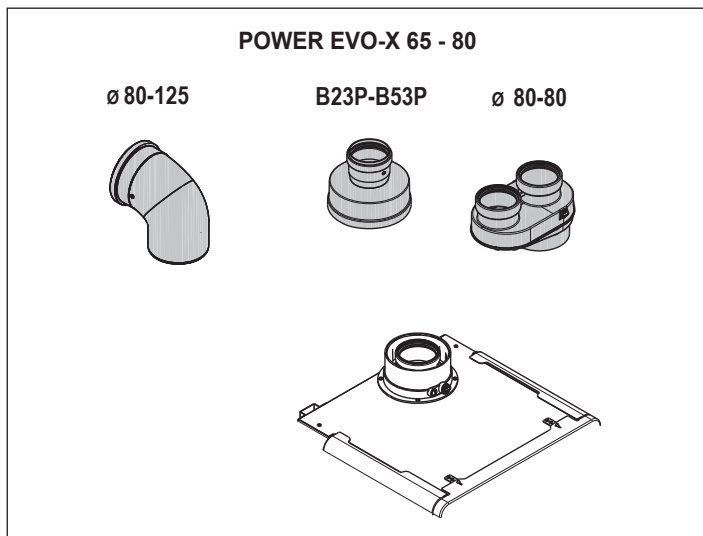
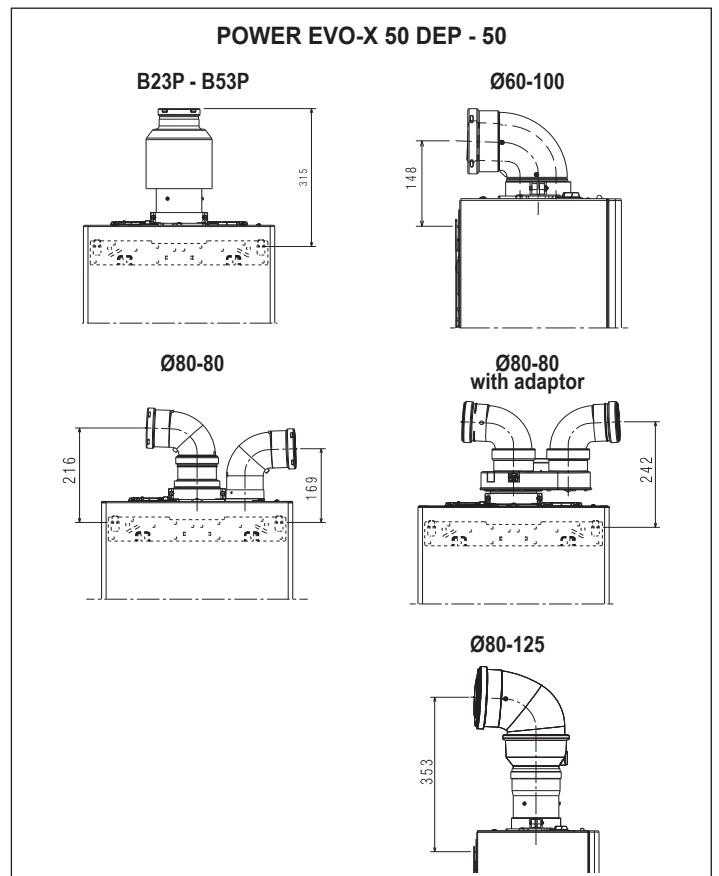
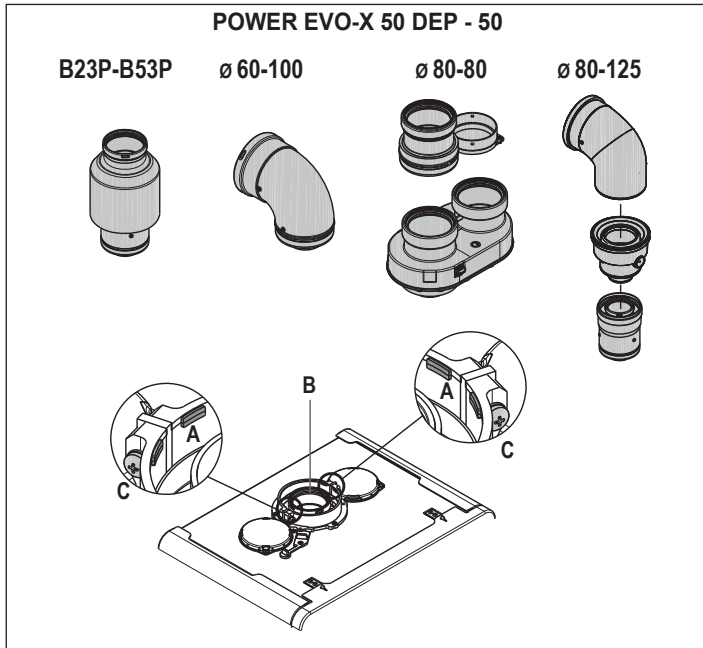

POWER EVO-X 50 DEP - 50

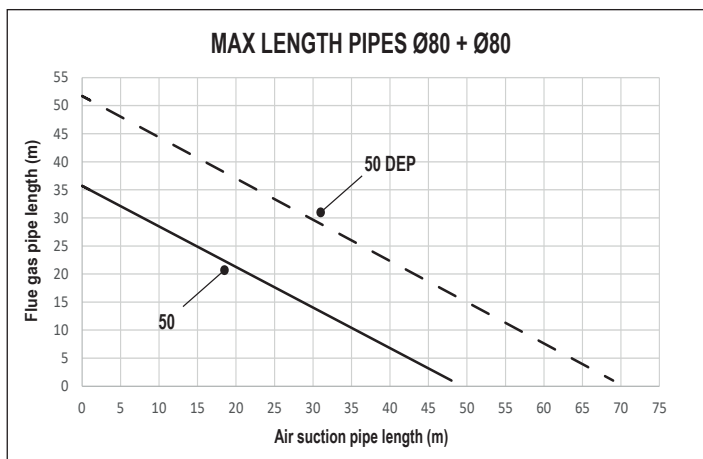

POWER EVO-X 65 - 80

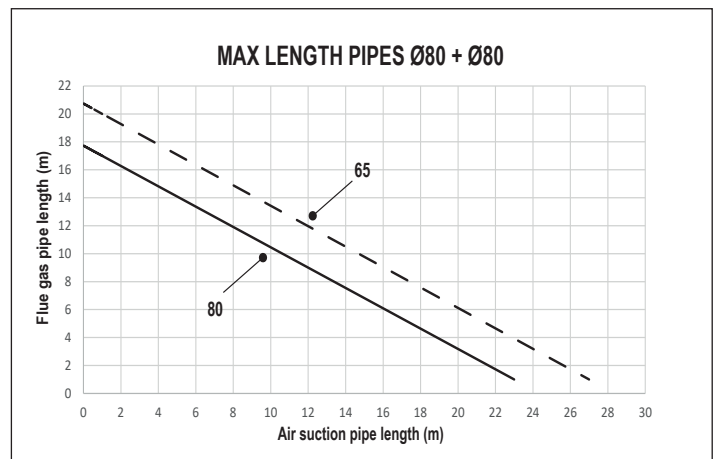

Ø 80-125 CURVE INSTALLATION on POWER EVO-X 65 - 80

For this type of installation it is necessary to use the spacer kit for wall fixing, available on request. Prepare the assembly by positioning the flue exhaust cardboard template, the spacers and the fixing crosspiece as shown in the figure.

Complete the installation using the bend and extension Ø 80-125 available as an accessory in the catalogue.

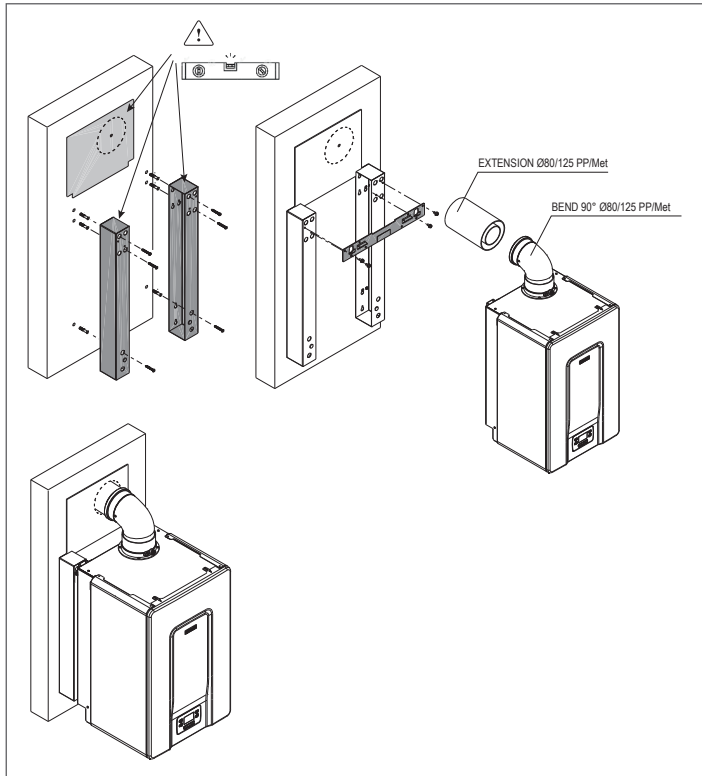

TYPE "B" INSTALLATION

Discharge Ø 80 mm

Model	Maximum length Ø 80 mm	Pressure loss	
		bend 45°	bend 90°
POWER EVO-X 50 DEP	48 m	1 m	1,5 m
POWER EVO-X 50	33 m	1 m	1,5 m
POWER EVO-X 65	17 m	1 m	1,5 m
POWER EVO-X 80	13 m	1 m	1,5 m

With type B installation, the combustion air is taken from the room and delivered via the openings made on the rear panel of the appliance, which must be located in a suitable utility room that is well-aired.

TYPE "C" INSTALLATION

Concentric pipes Ø 80-125 mm

Model	Maximum length Ø 80-125 mm	Pressure loss	
		bend 45°	bend 90°
POWER EVO-X 50 DEP	25 m	1 m	1,5 m
POWER EVO-X 50	25 m	1 m	1,5 m
POWER EVO-X 65	10 m	1 m	1,5 m
POWER EVO-X 80	10 m	1 m	1,5 m

Concentric pipes ø 60-100mm

Model	Maximum length Ø 60-100 mm	Pressure loss	
		bend 45°	bend 90°
POWER EVO-X 50 DEP	10 m	1,3 m	1,6 m
POWER EVO-X 50	10 m	1,3 m	1,6 m
POWER EVO-X 65	-	1,3 m	1,6 m
POWER EVO-X 80	-	1,3 m	1,6 m

Separated pipes Ø 80 mm + Ø 80 mm

Model	Maximum length Ø 80+80 mm	Pressure loss	
		bend 45°	bend 90°
POWER EVO-X 50 DEP	30+30 m	1 m	1,5 m
POWER EVO-X 50	21+21 m	1 m	1,5 m
POWER EVO-X 65	12+12 m	1 m	1,5 m
POWER EVO-X 80	10+10 m	1 m	1,5 m

- ⚠ Do not install the flue gas exhaust near flammable or plastic materials, whose characteristics can be changed in the presence of high temperatures.
- ⚠ The straight length is intended without bends, and includes the terminals and joints.
- ⚠ The boiler is supplied without the flue gas/air suction kit, as it is possible to use the accessories for condensing appliances best suited to the installation characteristics (refer to the catalogue).
- ⚠ In the case of use of non-original flue gas exhaust and air intake ducts, the use of certified ducts compliant with the appliance to which they are connected must still be guaranteed, with a temperature class $\geq 120^{\circ}\text{C}$ and resistant to condensation.
- ⚠ To ensure the best installation safety, attach the pipes to the wall (or ceiling) using specific fixing brackets positioned in line with each joint (at a distance such that the length of each single extension is not exceeded) and immediately before and after every change of direction (bend).
- ⚠ The maximum pipe length values refer to the flue pipe accessories available in the catalogue.
- ⚠ It is compulsory to use specific pipes.
- ⚠ The non insulated flue gas outlet pipes are potential sources of danger.
- ⚠ The use of a longer pipe causes a loss of output of the boiler.
- ⚠ The exhaust pipes can face in the direction most suited to the installation requirements.
- ⚠ As envisaged by current legislation, the boiler is designed to take in and dispose of flue gas condensate and/or rainwater condensate deriving from the flue gas discharge system via its own drain-trap.
- ⚠ If a condensate relaunch pump is installed, check the technical output data (provided by the manufacturer) to ensure it works properly.

Fig. A

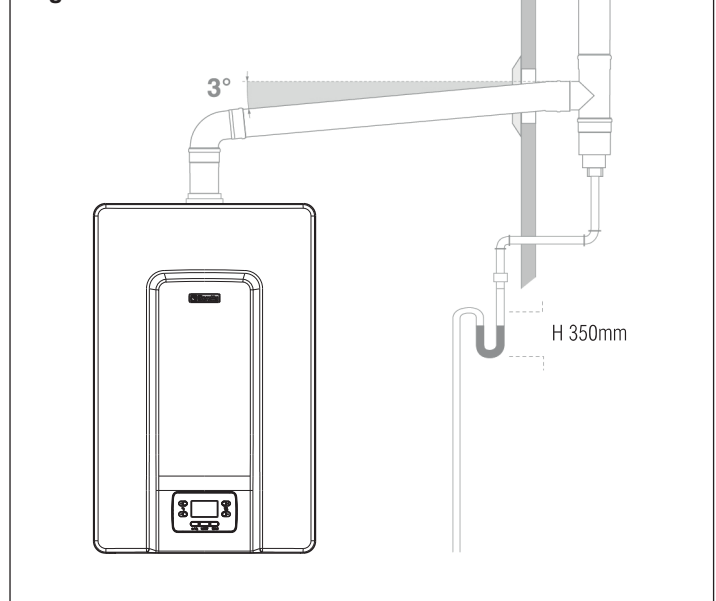

For changes of direction, use a T-fitting with inspection plug which allows easy periodic cleaning of the pipes.

Always ensure that the inspection plugs are hermetically closed, with the corresponding gasket in good condition, after cleaning.

2.14 Filling the heating system and eliminating air

In the case of a new installation or replacement of the boiler, it is necessary to clean the heating system beforehand. To ensure the device works well, after every cleaning intervention remember to top up the additives and/or chemical treatments (e.g. anti-freeze liquids, filming agents, etc.) and check the parameters are within the values indicated in the tables.

PARAMETERS	UM	HEATING CIRCUIT WATER	FILLING WATER
pH value		7-8	-
Hardness	°F	-	< 15
Appearance		-	clear
Fe	mg/kg	<0.5	-
Cu	mg/kg	<0.1	-

For the **POWER EVO-X** boiler, there must be a system filling line, preferably connected to the return line.

Before emptying or filling the system, disconnect the appliance from the electricity supply. For changes of direction, use a T-shaped fitting with an inspection plug that allows the piping to be easily cleaned periodically.

Always make sure that after cleaning the inspection plugs are hermetically sealed with the relative gasket.

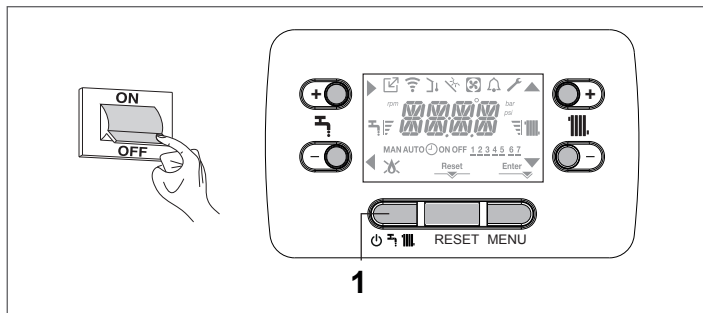

- Before filling the system, make sure the air outlet plug of the venting valve in the boiler is open (loosened)

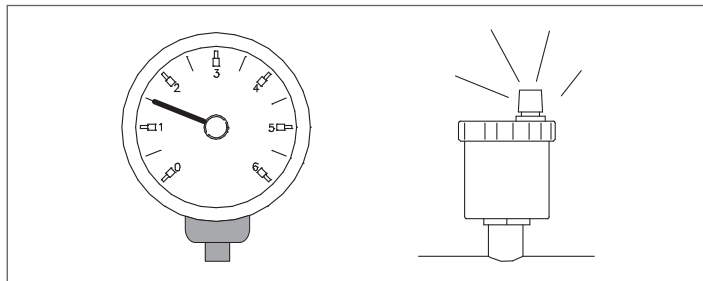

- Use the pressure gauge to check the pressure reaches the value envisaged for the system (1.5-2.0 bar)
- Reconnecting the electricity supply; the boiler will run the automatic venting cycle

NOTA: every time the boiler is electrically powered, the **automatic venting cycle is run (it lasts 6 min).**

NOTE: if there is a water alarm (E040, E041 or E042), the venting cycle cannot be carried out.

- If the system pressure is lower than 1 bar following the venting cycle, fill the system again.

2.15 Emptying the heating system

Before draining, set the boiler to OFF and shut off the electrical supply setting the main system switch to OFF.

- Close the heating system taps (if present).
- Connect a pipe to the system degassing/discharge tap (C), then manually loosen the valve to let the water flow out.
- After completing the operations, remove the pipe from the system degassing/discharge tap (C) and close the valve.

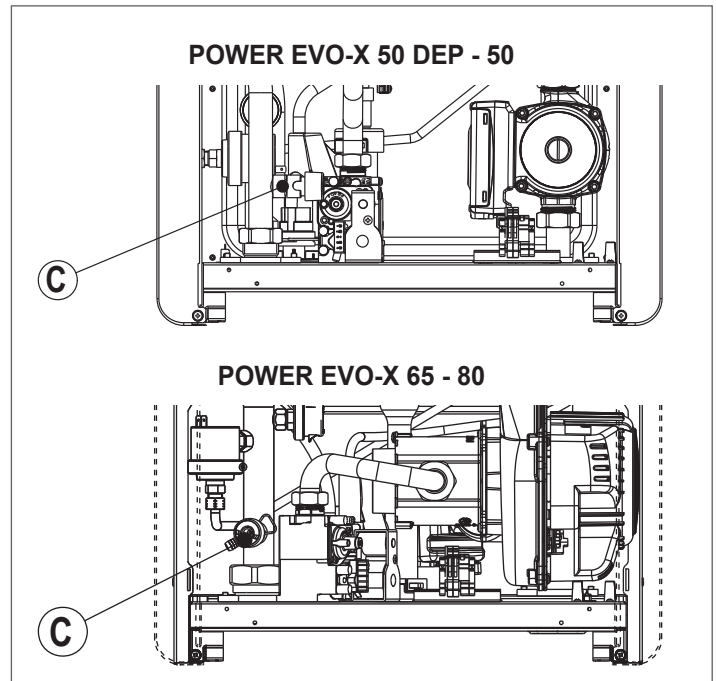

3 COMMISSIONING

3.1 Preliminary checks

The first ignition should be carried out by expert personnel from an authorised Technical Assistance Service Centre.

Before starting up the boiler, check:

- that the data of the supply networks (electricity, water, gas) correspond to the label data
- that the extraction pipes of the flue gases and the air suction pipes are working correctly
- that conditions for regular maintenance are guaranteed if the boiler is placed inside or between items of furniture
- the seal of the fuel adduction system
- that the fuel flow rate corresponds to the values required for the boiler
- that the fuel supply system is sized to provide the correct flow rate to the boiler, and that it has all the safety and control devices required by current regulations
- that the circulator rotates freely because, especially after long periods of non-use, deposits and/or residue may hamper its free movement (see paragraph "1.7 Manual circulator reset")
- that there is water in the drain-trap (if not, fill it).

After a long period of non-use or following maintenance work, at the first subsequent ignition (before starting up the appliance) it is vital to fill the condensate collection drain-trap by pouring about 1 litre of water into the boiler combustion analysis outlet and check:

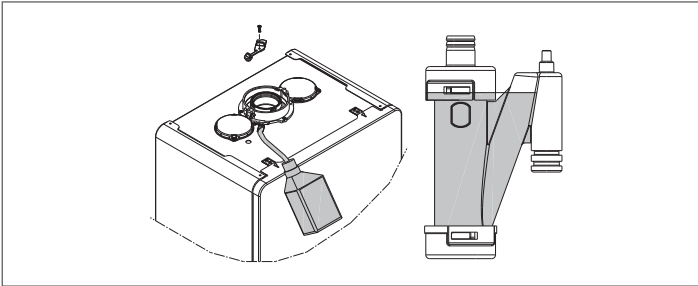

- the safety disc is floating
- the water leaving the boiler via the discharge tube is running off correctly
- the seal on the condensate discharge connection line is firm.

When the condensate discharge circuit (pipes and drain-trap) is working properly, the condensate does not exceed the maximum level (max). The preventive filling of the drain-trap, and the presence of the safety disc inside this element, aims to prevent the flue gases from escaping into the room.

High efficiency mode

The boiler is equipped with an automatic function that is activated at the first power supply or after 60 days of non-use (electrically powered boiler). In this mode the boiler, for 60 minutes, limits the heating power to a minimum and the maximum DHW temperature to 55°C. Activating the chimney sweep temporarily disables this function. The function is managed by parameter P7.08, which is set by default to 0 (function not active).

During execution, the function is shown on the display with the word HEM and, if P1.05 = 1, with the scrolling message "HIGH EFFICIENCY MODE"

3.2 Programming the boiler

- Turn the main system switch ON.
- Open the gas tap to allow fuel to flow.

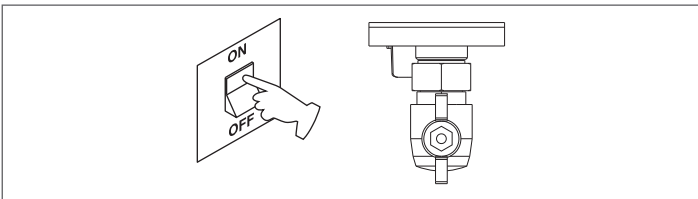

If necessary, the interface goes automatically to the **clock menu**. The main page shows the icons ▲, ▼, ► and ◀ lit up, along with ENTER, and the first two digits of the clock (00:00) will be flashing (0.5 sec ON, 0.5 sec OFF).

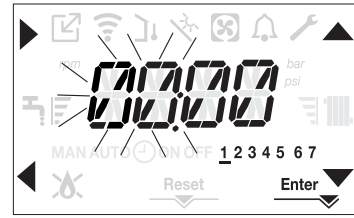

To set the time and day, proceed as follows:

- set the hour using the ▲ and ▼ arrows, then confirm with button **A**
- set the minutes using the ▲ and ▼ arrows, then confirm with button **A**
- set the day of the week using the ▲ and ▼ arrows. The segment corresponding to the selected day will flash. Press the MENU button in line with the Enter icon to confirm the time and day setting. The clock will flash for 4 seconds, then the main screen will be displayed again.
- to quit the time programming function without saving the new values, just press the ◀ button.

NOTE: the TIME and DAY settings can be modified at any time by accessing menu **P1**, parameter P1.02, or by pressing buttons **A+C** for at least 2 seconds.

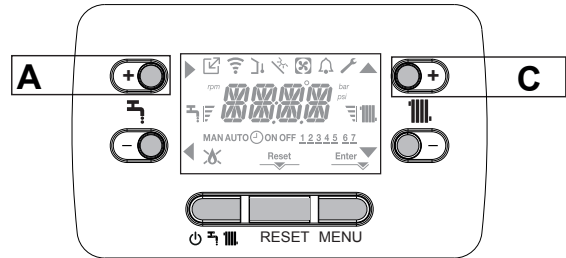

- If the language needs to be set, select menu **P1** and confirm with ►.
- Use the arrows to visualise parameter P1.01, then enter the sub-menu by pressing ►.
- Set the required language using the ▲ and ▼ buttons - see "1.10 Structure menu". Confirm your choice by pressing Enter.

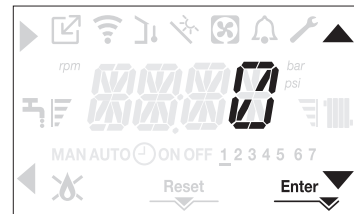

Every time the boiler is electrically powered, a venting cycle is run (it lasts 6 min). The display shows the message -AIR and the RESET icon lights up.

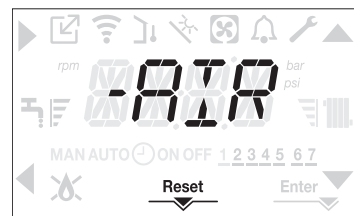

Press the RESET button to interrupt the venting cycle. Turn the boiler OFF by pressing ◻.

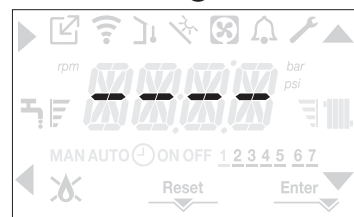

3.3 Setting the temperature control

TEMPERATURE CONTROL is enabled in the following way:

- access the technical parameters as explained in paragraph "1.14 Accessing the parameters"
- select menu **P4** and then P4.18 = 1

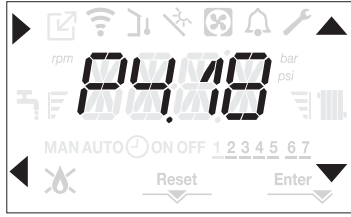

Temperature control only works with the outdoor temperature sensor connected, and is only active for the HEATING function.

If P4.18 = 0, or the outdoor temperature sensor is disconnected, the boiler will work with a fixed point. The temperature measured by the outdoor temperature sensor is shown in "3.22 INFO menu", item I009.

The temperature control algorithm does not use the measured outdoor temperature value directly; it uses a calculated outdoor temperature value that takes into account the building insulation: in buildings that are well insulated, the outdoor temperature variations will have less impact than those that are poorly insulated by comparison.

REQUEST FROM OT TIMED THERMOSTAT

In this case, the delivery setpoint is calculated by the timed thermostat on the basis of the outdoor temperature value, and by the difference between the real ambient temperature and the required ambient temperature.

REQUEST FROM ROOM THERMOSTAT

In this case, the delivery setpoint is calculated by the adjustment board on the basis of the outdoor temperature value, to obtain an estimated ambient temperature of 20° (reference ambient temperature).

There are 2 parameters that work together to calculate the output setpoint:

- slope of the compensation curve (KT)
- reference ambient temperature offset

Selecting the temperature control bend (parameter P4.19)

The temperature control bend for heating maintains a theoretical temperature of 20°C in the room when the outdoor temperature is between +20°C and -20°C. The choice of the curve depends on the minimum outdoor temperature envisaged (and therefore on the geographical location), and on the delivery temperature envisaged (and therefore on the type of system). It is carefully calculated by the installer on the basis of the following formula:

$$KT = \frac{\text{project delivery } T - T_{\text{shift}}}{20 - \text{min. design external } T}$$

Tshift = 30°C standard system
25°C floor installations

If the calculation gives an intermediate value between two bends, you are advised to choose the temperature control bend closest to the value obtained.

Example: if the value obtained from the calculation is 1.3, this is between curve 1 and curve 1.5. Choose the nearest curve, i.e. 1.5. The KT values that can be set are as follows:

- standard system: 1.0-3.0
- floor system 0.2-0.8

Use the interface to access menu **P4** and parameter P4.19 in order to set the predefined temperature control bend:

- access the technical parameters as explained in paragraph "1.14 Accessing the parameters"
- select menu **P4** and then P4.19
- press **▶** to confirm
- set the required control bend using the arrow buttons **▲** and **▼**
- confirm by pressing **Enter**.

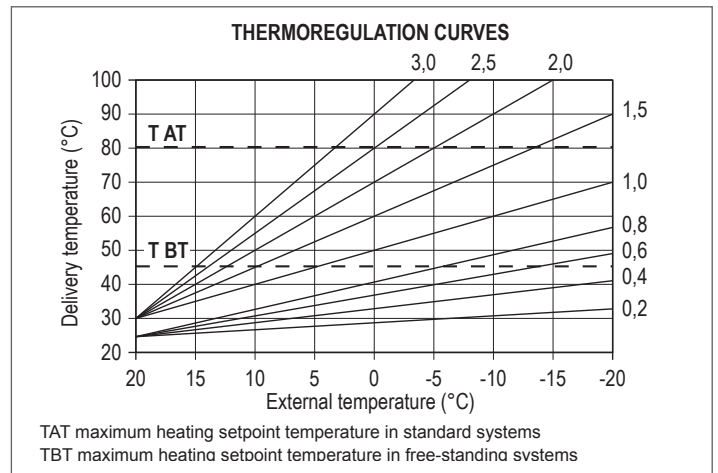

Reference ambient temperature OFFSET

In any case, the user can indirectly modify the HEATING setpoint value by inserting an offset on the reference temperature (20°C). This offset may vary from -5 to +5 (offset 0 = 20°C).

To correct the offset, refer to paragraph "3.8 Adjusting the heating water temperature with an outdoor temperature sensor connected".

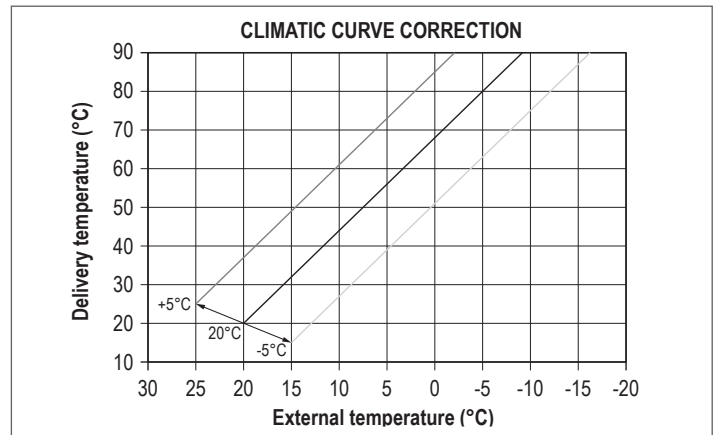

NIGHT-TIME COMPENSATION (parameter P4.20)

If a timer is connected to the ROOM THERMOSTAT input, night-time compensation can be enabled via menu **P4**, parameter P4.20. To set night-time compensation:

- access the technical parameters as explained in paragraph "1.14 Accessing the parameters"
- select menu **P4** and then P4.20
- press **▶** to confirm
- set the parameter value at 1
- confirm by pressing **Enter**

In this case, when the CONTACT is CLOSED, the heat request is made by the flow sensor on the basis of the outdoor temperature, to obtain a nominal temperature in the room at DAY level (20°C).

The OPENING of the CONTACT does not produce a switch-off, but a reduction (parallel translation) of the climatic curve on NIGHT level (16°C).

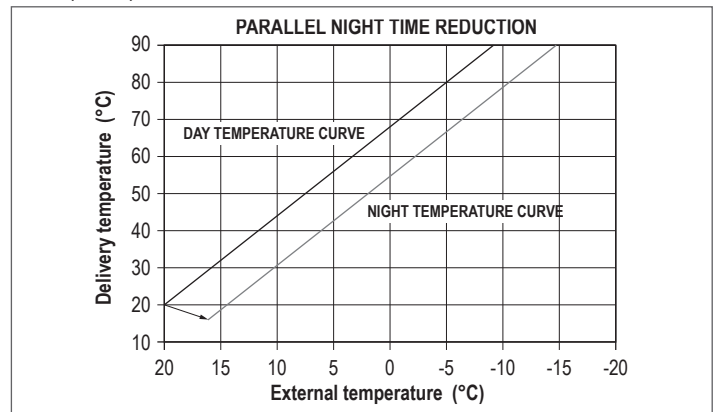

In this case too, the user can indirectly modify the HEATING setpoint value by inserting an offset on the reference DAY temperature (20°C) or NIGHT temperature (16°C). This offset may vary from [-5 to +5]. To correct the offset, refer to paragraph "3.8 Adjusting the heating water temperature with an outdoor temperature sensor connected".

3.4 Auto season change Winter - Summer

The system provides the possibility of making an automatic season change (from WINTER to SUMMER or vice versa) through the use of the parameter P1.07 SEASON AUTO-CHANGE.

If the parameter is active (P1.07=1) and the external probe is connected, the change of season occurs automatically. The external probe value used is the filtered one (I010). If P1.07=1, the settable parameters P1.08 and P1.09 determine at which temperature thresholds the transition, summer - winter or vice versa, occurs.

 Pay attention to the programming thresholds of parameters P1.08 - P1.09 and the positioning of the external probe, to avoid unwanted seasonal changes.

When the boiler is connected in a system with MSC/REC12 the parameters set on the REC12 prevail.

However, it is possible to set the boiler manually in OFF mode, in this condition the SEASON AUTO-CHANGE function is excluded.

3.5 Initial start-up

- When the power is switched on, the backlight is illuminated, all the icons and segments light up for 1 second, and the firmware version is visualised for 3 seconds:

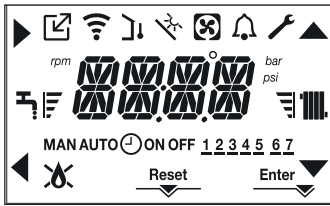

The interface then shows the status active in that moment.

Venting cycle

-  Every time the boiler is powered, the automatic venting cycle (lasting 6 min) is run. When the venting cycle is in progress, all heat requests are inhibited (apart from DHW requests when the boiler is not OFF) and the sliding message -AIR appears on the interface screen.

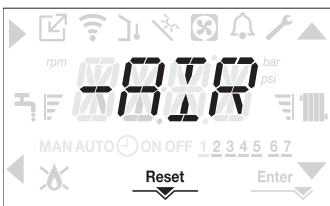

The venting cycle can be interrupted by pressing and holding button 2 (the RESET icon lights up on the display). The cycle can also be interrupted by a DHW request, if the boiler is not OFF.

- Adjust the room thermostat to the required temperature (~ 20°C) or, if the system is equipped with a timed thermostat or timer, make sure it is "active" and adjusted (~ 20°C).
- Now set the boiler on WINTER or SUMMER, depending on the type of operation required.
- The boiler will start up and then continue working until the set temperatures are reached, after which it will go back to standby.

3.6 Operating status

To change the operating status from WINTER to SUMMER and then to OFF, press button 1 until the relative icon appears on the display.

WINTER MODE

- Bring the boiler to WINTER mode by pressing button 1 until both the DHW icon and the heating icon appear on the display.



The interface normally displays the delivery temperature unless there is a DHW request in progress, in which case the DHW temperature is displayed.

- When there is a heat request and the boiler is igniting, the  icon appears on the display.

Heating REQUEST: the radiator icon flashes



SUMMER MODE (only with a storage tank connected)

- Bring the boiler to SUMMER mode by pressing button 1 until the DHW icon appears on the display.

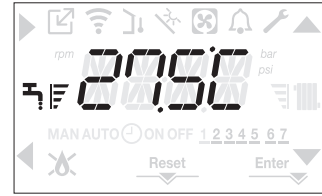

- In this status, the boiler activates the traditional "DHW-only" function and the interface usually shows the delivery temperature. In the case of DHW supply, the display will show the DHW temperature.

DHW REQUEST: the tap icon flashes

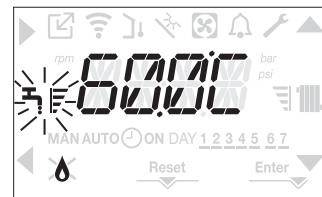

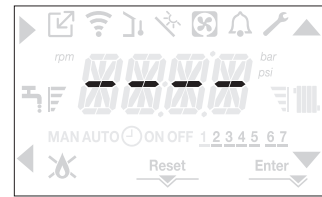

OFF

- Bring the boiler to OFF by pressing button 1 until central segments appear on the display.



3.7 Adjusting the heating water temperature without an outdoor temperature sensor connected (only in the case of a boiler with sensor)

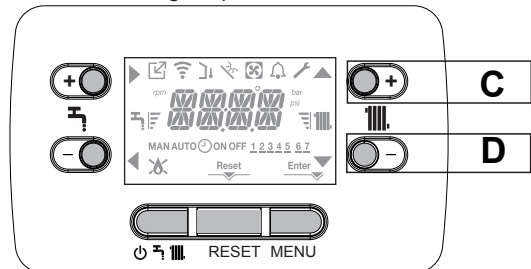

If there is no outdoor temperature sensor, the boiler works with a fixed point. In this case, the HEATING setpoint can be set from the main screen. Press button C or D to see the current heating setpoint value; the value will flash (0.5 sec ON, 0.5 sec OFF) and the  and  icons will light up.



Press button C or D again to set the heating setpoint value within the predefined range:

- [40°C ÷ 80.5°C] for high-temperature systems
 - [20°C ÷ 45°C] for low-temperature systems
- in steps of 0.5°C.

The level bars next to the heating icon show the setpoint value in relation to the operating range:

- 4 bars activated = max setpoint 
- 1 bar activated = min setpoint 



If button **C** or **D** is pressed and held, the meter will alter the set value more quickly. If no button is pressed for 5 seconds, the set value is taken as the new heating setpoint and the display returns to the main screen.

3.8 Adjusting the heating water temperature with an outdoor temperature sensor connected

If an outdoor temperature sensor is installed and temperature control is enabled (parameter P4.18 = 1), the delivery temperature value is automatically selected by the system, which quickly adjusts the ambient temperature according to the variations in the outdoor temperature. If you want to change the temperature value (increasing or reducing the value automatically calculated by the electronic board), you can alter the HEATING setpoint as follows: Press button **C** or **D** and select the required level within the range (-5 ÷ +5) (see paragraph "3.3 Setting the temperature control").

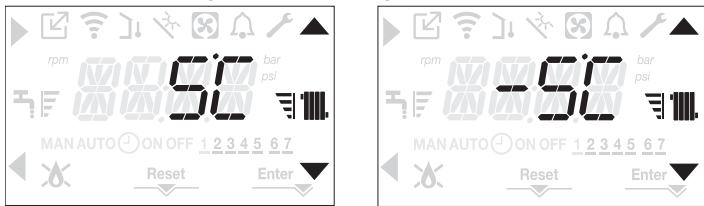

Note: if an outdoor temperature sensor is connected, the boiler can still work with a fixed point if you set parameter P4.18 = 0 (menu **P4**).

3.9 Adjusting the domestic hot water temperature

CASE A: heating-only, with no storage tank - adjustment not applicable

CASE B: heating-only + external storage tank with thermostat - adjustment not applicable

CASE C: heating-only + external storage tank with probe - to adjust the temperature of the DHW held in the storage tank, proceed as follows:

from the main screen, press button **A** or **B** to see the current DHW setpoint; the value will flash (0.5 sec ON, 0.5 sec OFF) and the ▲ and ▼ icons will light up.

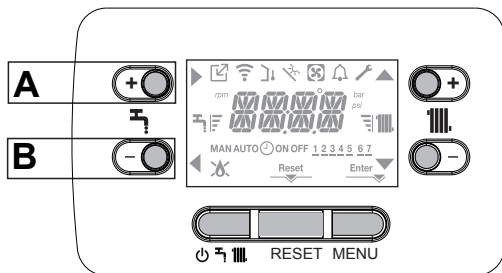

Press button **A** or **B** again to set the DHW setpoint, increasing or decreasing it in steps of 0.5°C within the predefined range. The level bars next to the heating icon show the setpoint value in relation to the operating range:

- 4 bars activated = max setpoint

- 1 bar activated = min setpoint



3.10 Safety stop

In the event of ignition faults or boiler operating faults, there will be a "SAFETY STOP". The display will show not only the code of the fault but also the flashing 🔔 icon (0.5 sec ON, 0.5 sec OFF). The backlight will flash for 1 min, then switch off, whereas the 🔔 icon will continue flashing.

The 4-digit space will show a sliding message containing the error code and a description.

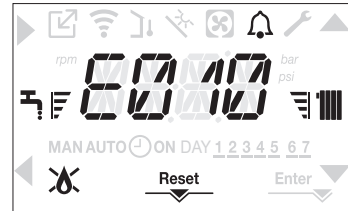

3.11 Reset function

The RESET icon lights up in the event of an alarm that needs to be manually reset by the user (e.g. a flame lockout). To reset the lockout, press button **2** Reset.

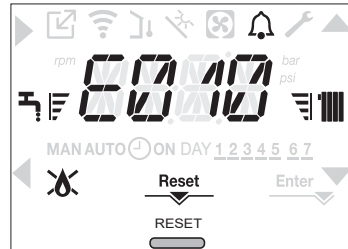

If the release attempts do not restart the boiler, contact your local Technical Assistance Centre.

3.12 Screed heater function

For a low temperature system the boiler has a "screed heater" function that can be activated in the following way:

- turn the boiler OFF by pressing button **1**

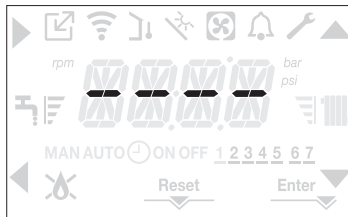

- access the technical parameters as explained in paragraph "1.14 Accessing the parameters"

- select menu **P4** and then item P4.09 with the ▲ and ▼ buttons, then confirm with ▶

(Note: SCREED HEATER is not available if the boiler is not OFF)

- to activate the function, set the parameter at 1; to deactivate it, set the parameter at 0

The screed heater function lasts 168 hours (7 days) during which, in the zones configured as low temperature, a heating request is simulated with an initial zone outlet of 20°C, then increased in line with the table below. By accessing the INFO menu from the main interface screen, you can see I001 relating to the number of hours that have elapsed since the function was activated. Once activated, the function takes priority, if the machine is shut down by disconnecting the power supply, when it is restarted the function picks up from where it was interrupted. The function can be interrupted before it reaches the end, by bringing the boiler to a status other than OFF or by selecting item P4.09 = 0 from menu **P4**.

DAY	TIME	TEMPERATURE
1	0	20°C
	6	22°C
	12	24°C
2	18	26°C
	0	28°C
	12	30°C
3	0	32°C
	0	35°C
4	0	35°C
	0	35°C
5	0	35°C
	0	35°C
6	0	30°C
	0	30°C
7	0	25°C
	0	25°C

3.13 Sliding delivery (only if a storage tank is connected)

Parameter P5.07 is used to activate the SLIDING STORAGE TANK DELIVERY function in order to modify the delivery setpoint used by the boiler when there is a DHW request. The factory setting for this parameter is "function not active", which provides for modulation at a fixed delivery value of 80°C during a DHW request. To activate the value, access the parameters as explained in paragraph "1.14 Accessing the parameters", then select menu **P5** and item P5.07. To activate the function, use the buttons to select a value of 1 and confirm with Enter. In this case, the delivery setpoint is no longer fixed at 80°C during a DHW request; it is variable, and is calculated automatically by the boiler on the basis of the difference between the required DHW setpoint and the temperature measured by the storage tank probe.

Note: it is not advisable to activate this function for storage tanks with a capacity of more than 100 litres, as the operation to load the tank would be too slow.

It might be necessary to reset the value of this parameter if the adjustment board is replaced.

3.14 Anti-legionella function (only if a storage tank with probe is connected)

The appliance has an automatic ANTI-LEGIONELLA function which, when necessary (either daily or weekly, depending on the setting), heats the DHW at 65°C and keeps it at that temperature for 30 minutes to destroy any bacterial proliferation in the storage tank. The function is not carried out if the temperature of the storage cylinder reached 65°C over the last 24h, for daily scheduling, or in the last 7 days, in the case of weekly scheduling.

If this function is activated, it is implemented every day at 3.00 a.m. if programmed on a daily basis, or else every Wednesday at 3.00 a.m. if programmed on a weekly basis. Once activated, the function takes top priority and cannot be interrupted.

⚠ The function is not carried out with the boiler set to OFF.

The ANTI-LEGIONELLA function can be activated by accessing the parameters menu (see "1.14 Accessing the parameters") and selecting parameter P5.01 in menu **P5**.

To activate the function, use the buttons to select a value of 1 and confirm with Enter.

3.15 Special function: simultaneous DHW and HEATING (P5.14)

Parameter P5.14, if set to 1, allows you to manage the simultaneity of heat demand from the boiler to the water-tank and the heating circuit (only in cases in which the parameter hydraulic configuration P3.01 is 3 or 4 i.e. a configuration with water-tank).

To use this configuration correctly it is necessary that parameter P3.11 (CONFIG AUX) is set to 2, so that the ITRF05 manages the additional pump.

In case of simultaneous use, if the heating request ends and the burner is lit (due to the presence request of the water-tank) the additional pump comes off after 2s.

Parameter P5.15 represents an offset on the del setpoint DHW and heating circuit.

In case of simultaneity, this parameter allows you to raise the delivery setpoint by the value set in the parameter.

3.16 Checks during and after the first commissioning

After starting up, check that the boiler carries out the start-up procedures and subsequent shut-down properly.

- Also check operation in DHW mode (if a storage tank is installed) by turning on a hot water tap.
- Check operation with the boiler in SUMMER mode (if there is a storage tank) or WINTER mode.
- After a couple of minutes of continuous operation.
- Obtained by turning the main system main switch to ON, setting the boiler status to Summer and keeping open the DHW service open, the binders and processing residue will have evaporated and it will be possible to run a combustion check.

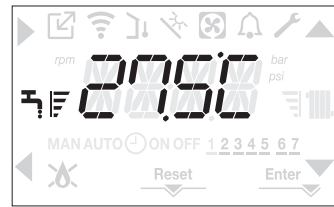

3.17 Combustion check

⚠ The checks of the CO₂ value adjustments in relation to the reference parameters (indicated in the tables below) must be carried out with the casing closed. The opening of the casing involves a reduction of about 0.2% of the values, and depends on the installation configuration (the type and length of the discharge and suction pipes).

⚠ Use the flue gas analysis probe adaptor.

To carry out the combustion analysis, proceed as follows:

- Turn the boiler OFF by pressing button **1**

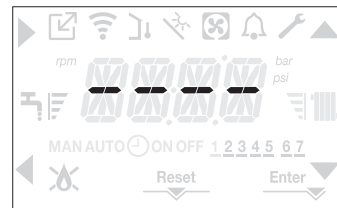

POWER EVO-X 50 DEP - 50

- Remove the screw and cover on the upper wall (**A-B**).
- Insert the analysis probe adaptor (**D**) (included in the documentation bag) in the combustion analysis hole.
- Insert the flue gas analysis probe in the adaptor.

POWER EVO-X 65 - 80

- Remove the screw **A**.
- Insert the flue gas analysis probe in the hole.

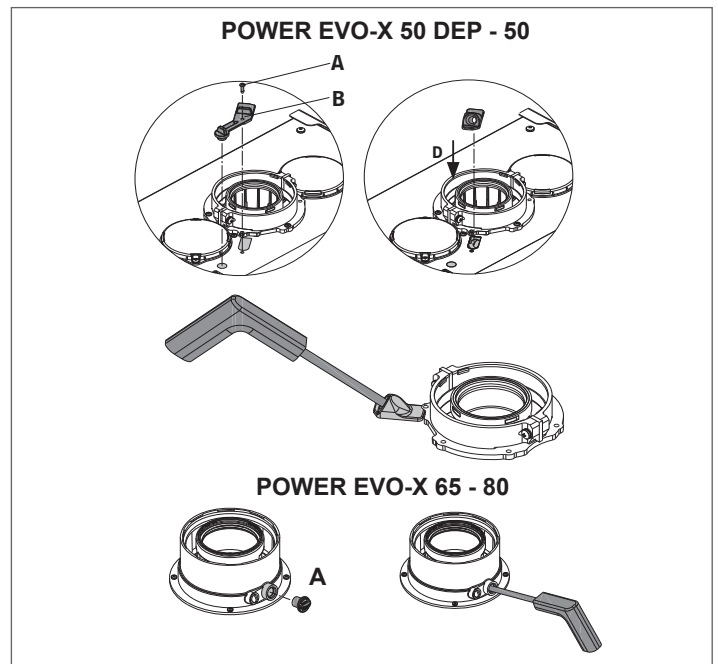

- Activate the combustion control function by pressing buttons **2+3** for at least 2 seconds.

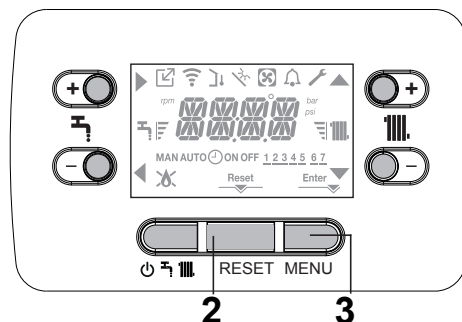

- The display will show CO and the ▲, ▼, ► and ◀ icons will light up. The boiler operates at the maximum heating output.



- Use the ▲ and ▼ buttons to modify the fan speed.
- Set the maximum value, then confirm by pressing ►. The display will show the defined rpm for 10 sec, along with the rpm icon.

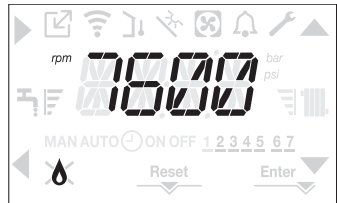

The boiler will work at the maximum output.

- Check the max CO₂ value shown on the analyser complies with the indications in the table. If it doesn't, calibrate the gas valve - see paragraph "3.19 Gas valve calibration".

Max. CO ₂	METHANE GAS (G20)	LIQUID GAS (G31)	
50 DEP	9,0	10,0	%
50	9,0	10,0	%
65	9,0	10,0	%
80	9,0	10,0	%

- Set the minimum value, then confirm by pressing ►. The display will show the defined rpm for 10 sec, along with the rpm icon.

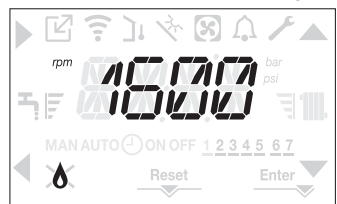

The boiler will work at the minimum output.

- Check the min CO₂ value shown on the analyser complies with the indications in the table. If it doesn't, calibrate the gas valve - see paragraph "3.19 Gas valve calibration".

Min. CO ₂	METHANE GAS (G20)	LIQUID GAS (G31)	
50 DEP	9,0	10,0	%
50	9,0	10,0	%
65	9,0	10,0	%
80	9,0	10,0	%

The function can be interrupted by pressing the ◀ button.

When the check has ended:

- quit the function by pressing ◀
- remove the analyser probe and close the combustion analysis outlet with the relative plugs and screw
- put the analysis probe adapter (supplied with the boiler) in the documentation bag
- set the boiler to the required operating mode, depending on the season
- regulate the requested temperature values according to needs

⚠ When the combustion analysis function is active, all heat requests are inhibited and the sliding message "CO" appears on the display.

IMPORTANT

The combustion analysis function is active for max. 15 minutes. The burner shuts down if an outlet temperature of 95°C is reached; it will ignite again when the temperature falls below 75°C.

⚠ With the OT+ device connected, the combustion control function cannot be activated. To make a flue gas analysis, detach the OT+ connection wires then wait 4 minutes, or disconnect the electricity supply and then repower the boiler.

⚠ The combustion analysis function is usually activated with the 3-way valve positioned on heating, but it is possible to switch the valve to DHW by generating a DHW request at maximum output while the function is active. In this case, the DHW temperature is limited to a maximum value of 65°C. Wait for the burner to fire.

3.18 Adjustments

The boiler was adjusted by the manufacturer at the time of production. If the adjustments need to be made again however, for example after extraordinary maintenance, the replacement of the gas valve or conversion from methane gas to LPG or viceversa, follow the procedures explained below.

The adjustments of the maximum and minimum output, heating maximum and slow ignition, must necessarily be made in the sequence indicated, and by qualified personnel only.

- power the boiler
- access the parameters as explained in paragraph "1.14 Accessing the parameters"
- select menu P3 and confirm with ►
- use the arrows to visualise the parameter required - see table -

P3.06	minimum fan speed
P3.07	maximum fan speed
P3.08	slow ignition
P3.09	maximum fan speed - heating
P3.13	reignition speed

- enter the sub-menu by pressing ►
- set the required values with the ▲ and ▼ buttons, referring to the following tables
- make sure P3.09=P3.10

MAXIMUM NO. FAN ROTATIONS	METHANE GAS (G20)	LIQUID GAS (G31)	
50 DEP	7.300	7.100	rpm
50	9.100	8.900	rpm
65	6.800	6.300	rpm
80	8.200	7.800	rpm

MINIMUM NO. FAN ROTATIONS	METHANE GAS (G20)	LIQUID GAS (G31)	
50 DEP	1.750	1.650	rpm
50	1.750	1.650	rpm
65	1.850	1.750	rpm
80	1.850	1.750	rpm

NO. FAN ROTATIONS (SLOW IGNITION)	METHANE GAS (G20)	LIQUID GAS (G31)	
50 DEP	4.000	4.000	rpm
50	4.000	4.000	rpm
65	3.000	2.400	rpm
80	3.000	2.400	rpm

- confirm the values with Enter.

3.19 Gas valve calibration

Run the CO₂ check procedure as explained in paragraph "3.17 Combustion check". If the values need to be modified, proceed as follows:

- check the CO₂ values with the casing closed
- remove the casing as explained in paragraph "2.10 Removing the casing"
- check the CO₂ values again, with the casing open

- bearing in mind the difference between the values measured with the casing closed and open, if necessary adjust the CO₂ to the value shown in the table - (minus) the difference noted.
Example:
 - CO₂ value measured with the casing closed = 8.5%
 - CO₂ value measured with the casing open = 8.3%
 - value to be set for CO₂ with casing open = 8.8%
 - value that must be measured for CO₂ with casing closed = 9.0%
- for the CO₂ value adjustments:
 - rotate the maximum output adjustment screw clockwise to reduce the value, or anti-clockwise to increase it
 - rotate the minimum output adjustment screw clockwise to increase the value, or anti-clockwise to reduce it
- with the casing open, and after adjusting the CO₂ value at the minimum output, check the CO₂ value at the maximum output again
- after completing the adjustments, refit the casing and check the CO₂ value corresponds to the one shown in the table

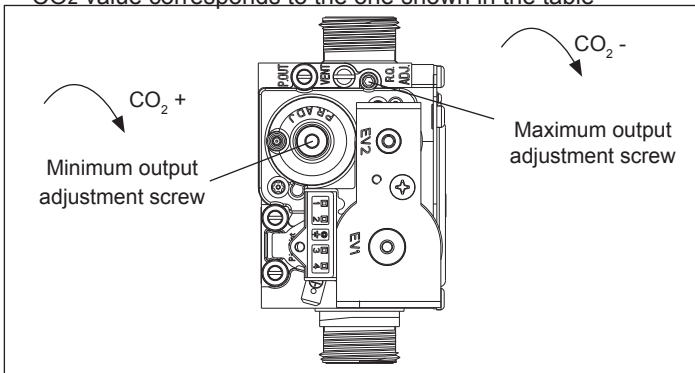

3.20 Gas conversion

It is easy to make the conversion from one gas to another even after the boiler has been installed.

This operation must be carried out by professionally qualified personnel. The boiler is designed to operate with methane gas (G20) according to the product label. It is possible to convert the boiler to LPG with the aid of the relative kits.

For disassembly refer to instructions below:

- disconnect the boiler from the electricity supply and turn off the gas tap
- remove the casing as explained in paragraph "2.10 Removing the casing"
- release the instrument panel and rotate it forwards.

For POWER EVO-X 50 DEP - 50 models

- Loosen the nut of the gas train (A).
- Remove the nozzle (B) inside the gas valve, and replace it with the one in the kit.

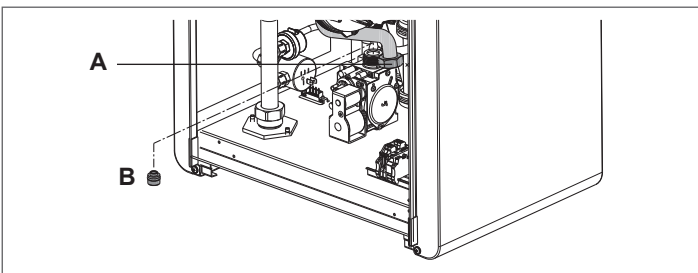

For POWER EVO-X 65 - 80 models

- Disconnect the gas train (A) of the mixer.
- Loosen the 3 screws (B) fastening the mixer to the fan, and remove it.
- Loosen the 2 screws (C) fastening the plastic Venturi tube to the aluminium body, then lever it off with the aid of a screwdriver (do not apply excessive force, as the plastic teeth may get damaged).
- Take out the Venturi tube.
- Replace the mixer+ nozzle assembly (D) with the one in the kit.

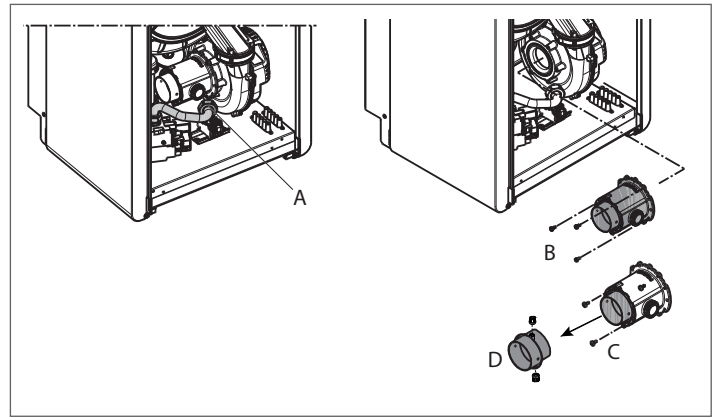

After completing the operations:

- refit the previously removed components
 - power the boiler and turn on the gas tap
- Adjust the boiler as explained in paragraph "3.18 Adjustments" and paragraph "3.19 Gas valve calibration".

- ⚠ Conversion must be carried out by qualified personnel.
- ⚠ After the transformation, apply the new rating plate included in the kit.

3.21 Signalling and faults

In there is a fault, the 🔔 icon will flash (0.5 sec ON, 0.5 sec OFF). The backlight will flash for 1 min (1 sec ON, 1 sec OFF) and then switch off, but the bell will carry on flashing. The 4-digit area of the display will show a sliding message with the error code.

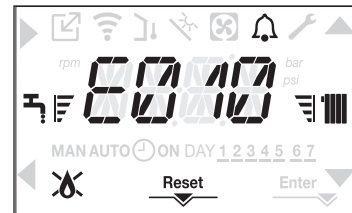

The following icons may appear when a fault arises:

- 🔥 lights up for a flame alarm (E010)
- RESET lights up for an alarm that needs to be manually reset by the user (e.g. a flame lockout)
- 🔧 lights up along with the 🔔 icon (apart from flame lockout and water failure faults)

In addition, when parameter P3.02 is set with a value of 1, meaning that a water pressure transducer is fitted, the pressure value is shown when it is higher than 5.0 bar (excessively high pressure); the boiler carries on working as these are merely info messages.

With pressure lower than 0.8 bar (excessively low pressure) the boiler stops functioning.

In these cases, the pressure value, with the relative measurement unit, is also shown at the end of the following error messages:

- E041
- E040

Reset function

To reset boiler operation in the event of a fault, press the RESET button. At this point, if the correct operating conditions have been restored, the boiler will restart automatically. Up to 5 consecutive reset attempts can be made on the interface, after which the display will show code E099. In this case, the boiler must be disconnected from the electricity supply and then reconnected again, to reactivate operation.

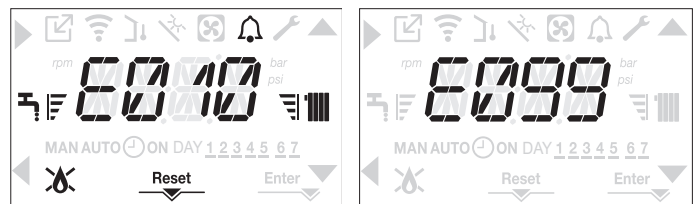

⚠ If the reset attempts fail to activate boiler operation, contact the Aftersales Service.

Fault E020

in the event of frequent intervention of the limit thermostat (especially in the POWER EVO-X 65 and 80 boilers), check whether parameter P4.11 is programmed at 1 and take it to 0 to reset the timings envisaged for the heating phases.

Fault E041

If the pressure value falls below the safety value of 0.8 bar, the boiler shows fault code E041 for 10 min.

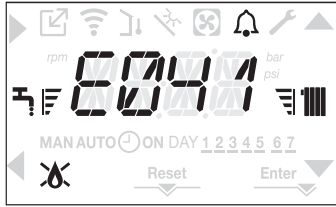

When the transitional time has finished, if the fault persists the fault code E040 is displayed.

When fault E040 has occurred, the boiler must be manually filled via a filling system (to be installed on the system, preferably connected to the return line) until the pressure is between 1.5 and 2.0 bar.

Then press RESET.



Close the filling system, making sure you hear the mechanical click. After filling, run the automatic venting cycle as explained in paragraph “2.14 Filling the heating system and eliminating air”.

⚠ If pressure drops happen very frequently, contact the Aftersales Service.

Fault E060

On heating-only models with a storage tank with probe connected, fault E060 prevents operation in DHW mode.

Fault E091

The boiler has an auto-diagnostic system which, based on the total number of hours in certain operating conditions, can signal the need to clean the primary exchanger (alarm code E091).

Once the cleaning operation has been completed, reset to zero the total hour meter with special kit supplied as an accessory following procedure indicated below:

- access the technical parameters as explained in paragraph “1.14 Accessing the parameters”
- select menu **P3** and then item P3.12, using the ▲ and ▼ buttons
- set the parameter value at 1, confirming with **Enter**

NOTA: The meter resetting procedure should be carried out after each in-depth cleaning of the primary exchanger or if this latter is replaced.





The total hours can be verified in the following way:

- access the INFO menu as explained in paragraph “3.22 INFO menu” and visualise item I015 to see the value of the flue gas probe meter.

ERROR CODE	ERROR MESSAGE	DESCRIPTION OF TYPE OF ALARM
E010	Flame lockout Condensate drain obstructed Flue gas exhaust/air suction obstructed Differential pressure switch	definitive
E011	Extraneous flame	transitional
E020	Limit thermostat	definitive
E030	Fan fault	definitive
E040	Fill the system	definitive
E041	Fill the system	transitional
E042	Pressure transducer fault	definitive
E060	DHW probe fault	transitional
E070	Flow sensor fault Flow sensor overtemperature Flow/return sensor differential	transitional definitive definitive
E080	Return probe fault Return probe overtemperature Return-flow sensor differential	transitional definitive definitive
E090	Flue gas probe fault	transitional
E091	Clean primary heat exchanger	transitional
E058	Low power supply voltage	transitional
E059	High power supply voltage	transitional
E099	Reset attempts exhausted	definitive
CFS	Call Service	signal
SFS	Stop for Service	definitive
< 0,8 bar	Low pressure - check system	signal
>5,0 bar	High pressure - check system	signal

3.22 INFO menu

Press button **3** from the initial display screen to see a series of information items relating to boiler operation, listed according to the parameter name and value.

To switch between parameters, press the  and  buttons. Press  to see the selected parameter; press  to return to the main screen.

PARAMETER NAME		DESCRIPTION
I001	Screed heater hours	Number of hours of screed heater operation (when function in progress)
I002	Flow sensor	Boiler flow sensor value
I003	Return probe	Boiler return temperature sensor value
I004	Domestic hot water probe	Value of high storage tank probe
I006	Low storage tank probe	Value of low storage tank probe (if a solar storage cylinder is installed)
I007	Collector temp	Solar collector probe value (case C and solar system present)
I008	Flue gas probe	Flue gas probe value
I009	Outdoor temperature sensor	Instantaneous outdoor temperature sensor value
I010	External temp. for temperature control	Filtered outdoor temperature sensor value used in the temperature control algorithm to calculate the heating setpoint
I011	DHW flow rate	DHW setpoint only with OT+ connection
I012	Fan rotations	Number of fan rotations (rpm)
I013	Flow sensor (main zone)	Main zone flow sensor value (when P4.12 = 1)
I014	Flow sensor (zone 1)	Zone 1 flow sensor value (when 1 P4.23 = 1)
I015	Flue gas probe meter	Number of operating hours of the heat exchanger in "condensing mode" (the values, in thousands, are visualised/100)
I016	Delivery setpoint (main zone)	Main zone delivery setpoint
I017	OT+ heating setpoint	Heating setpoint sent to the boiler from the OT+ remote control
I018	System pressure	System pressure
I019	DHW hours	This counter measures the burner "ON" time (flame presence) in DHW mode, value expressed in seconds
I020	CH hours	Hours burner on in heating
I021	% DHW modulation	This counter measures the average modulation percentage (ID17) when burner on in DHW
I022	% CH modulation	Average percentage value of modulation with burner on in heating
I023	Average heating flow probe	Average flow probe values with burner on in heating mode
I024	Average DHW flow probe	Not used if parameter P3.01 = 0
I025	Average heating return probe	Average return probe values with burner on in heating mode
I026	Average DHW return probe	Not used if parameter P3.01 = 0
I027	Number cycles ON EVG	Number of gas valve ON cycles
I028	Ionisation current	Instantaneous ionisation current detected by the detection electrode
I029	High efficiency mode	Indicates when the high efficiency mode is running
I033	Board ID	Electronic board identification
I034	Board fw rev	Firmware revision of the electronic board
I035	Interface fw rev	Firmware revision of the interface
I039	Alarm log 1 (oldest)	List of the last 5 alarms recorded
I040	Alarm log 2	
I041	Alarm log 3	
I042	Alarm log 4	
I043	Alarm log 5 (most recent)	
I044	No. of days for CFS	

3.23 Temporary switch-off

In the event of temporary absences (weekends, short breaks, etc.) set the status of the boiler to OFF .



The electricity supply and fuel supply remain active, so the system is protected by:

- **heating anti-freeze:** this function is activated if the temperature measured by the flow sensor drops below 5°C. A heat request is generated in this phase, with burner ignition at minimum output and maintained at this level until the delivery water temperature reaches 35°C;
- **DHW anti-freeze (if water tank with probe):** this function is activated if the temperature measured by the water tank probe drops below 5°C. A heat request is generated in this phase, with burner ignition at minimum output and maintained at this level until the delivery water temperature reaches 55°C;

 The activation of the ANTI-FREEZE function is signalled by a sliding message on the interface display: AF1 (DHW ANTI-FREEZE IN PROGRESS) or AF2 (HEATING ANTI-FREEZE IN PROGRESS), depending on the situation.

- **circulator anti-blocking:** the circulator activates every 24 hours of stoppage for 30 seconds.

3.24 Switching off for lengthy periods

If the boiler is not used for a long time, the following operations must be carried out:

- set the status of the boiler to 
- set the system's main switch to "off"
- turn off the fuel and water taps of the heating and domestic hot water system.

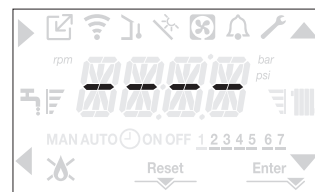

In this case, the anti-freeze and anti-blocking systems are deactivated. Drain the heating and domestic water system if there is any risk of freezing.

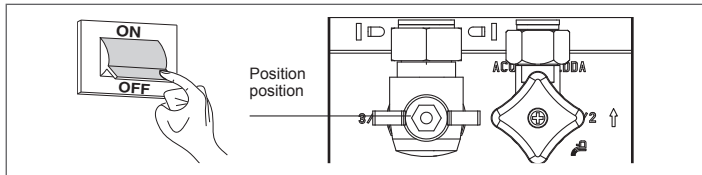

3.25 Keypad lock function

Press buttons 1+3 for at least 2 seconds to activate the keypad lock; press them again for at least 2 seconds to deactivate the lock. The display shows the sliding string LOCK.

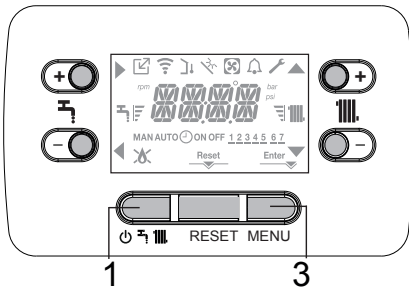

Button 2 may remain active if there is a fault, so the alarm can be reset.

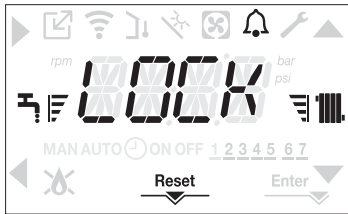

3.26 Alarm log

The alarm log is active with parameter P7.01=1 (SERVICE).

The alarms can be visualised:

- in the INFO menu (from I039 to I043), in chronological order from the most recent to the oldest, up to a maximum of 5 after 2 hours of operation
- on the OT+ remote control (if connected and supported)

If an alarm occurs several times consecutively, it is saved only once. To reset the alarm, follow the indications given in paragraph "3.11 Reset function".

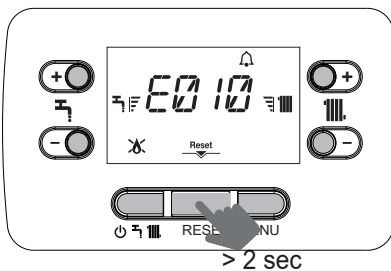

3.27 Interface standby

If there are no faults or heat requests, the display always shows the temperature measured by the flow sensor. After 10 seconds with no heat requests and no buttons pressed, the interface goes into standby. The display shows the current time, with the two points separating the hours from the minutes flashing (0.5 sec ON, 0.5 sec OFF). The status icons will be activated if necessary:

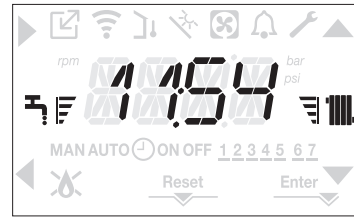

3.28 Replacing the interface

System configuration operations must be carried out by professionally qualified Aftersales Service personnel.

If the interface board is replaced, the user may be asked to reset the time and day values (see paragraph "3.2 Programming the boiler") when the power is switched back on. Note that it is not necessary to reprogram the configuration parameters as their values are retrieved by the adjustment and control board in the boiler. It may, however, be necessary to reset the DHW and heating set-point values.

3.29 Replacing the board

If the adjustment and control board is replaced, it may be necessary to reprogram the configuration parameters.

In this case, refer to the parameter table ("1.10 Structure menu") to see the board default values, the factory-set values, and the personalised values.

The most important parameters which must be checked and possibly reset when the board is replaced are the following:

- P3.01
- P3.02
- P3.03
- P3.06
- P3.07
- P3.08
- P3.09
- P5.07
- P7.08 (WARNING - set the parameter at 0).

4 MAINTENANCE AND CLEANING

Regular maintenance is an obligation required by the law and is essential to the safety, efficiency and duration of the boiler.

Schedule maintenance in time 

It allows for the reduction of consumption, polluting emissions and keeping the product reliable over time.

Before beginning the maintenance tasks:

- Turn off the fuel and water taps of the heating and domestic hot water system.

To ensure product characteristics and efficiency remain intact and to comply with prescriptions of current regulations, it is necessary to render the appliance to systematic checks at regular intervals. When carrying out maintenance work, respect the instructions given in the "1 WARNINGS AND SAFETY" chapter.

This normally means the following tasks:



- removing any oxidation from the burner
- removing any scale from the heat exchangers
- checking electrodes
- checking and cleaning the drainage pipes
- checking the external appearance of the boiler
- checking the ignition, switch-off and operation of the appliance, in both domestic water mode and heating mode
- checking the seal on the couplings, gas and water and condensate connecting pipes
- checking the gas consumption at maximum and minimum output
- checking the position of the ignition electrode
- checking the position of the detector electrode (see specific paragraph)
- checking the gas failure safety device



 The use of protective clothing is recommended during the installation of the boiler, to avoid any risk of personal injury.

 After carrying out the necessary maintenance operations, a flue gas analysis must be run to guarantee correct operation.

 If, after replacing the electronic board or carrying out maintenance on the detection electrode or burner, the flue gas analysis returns values outside the tolerance range, it may be necessary to modify them as explained in paragraph "3.17 Combustion check".

NOTA: If the electrode is replaced, there might be slight variations in the combustion parameters that return within the nominal value range after a few hours of operation.

 Do not clean the appliance or its parts with inflammable substances (e.g. petrol, alcohol, etc.) .

 Do not clean panels, painted parts and plastic parts with paint thinner .

 Panel cleaning must be carried out only with soapy water .

Cleaning the primary heat exchanger

- Disconnect the electricity supply by turning the main system switch to OFF.
- Close the gas shut-off valve.
- Remove the casing as explained in paragraph "2.10 Removing the casing".
- Disconnect the connecting cables of the electrodes.
- Disconnect the power cables of the fan.
- Take out the clip (A) of the mixer.
- Loosen the nut of the gas train (B).
- Take out and rotate the gas train.
- Remove the 4 nuts (C) that fix the combustion unit.
- Take out the air/gas conveyor assembly including the fan and mixer, being careful not to damage the insulating panel and the electrodes.
- Remove the siphon connecting pipe from the condensate drain fitting of the heat exchanger and connect a temporary collecting pipe. At this point proceed with the heat exchanger cleaning operations.

- Vacuum out any dirt residue inside the heat exchanger, taking care NOT to damage the retarder insulating panel.
- Clean the coils of the heat exchanger with a soft bristled brush.

 DO NOT USE METAL BRUSHES THAT COULD DAMAGE THE COMPONENTS

- Clean the spaces between the coils using a blade (0.4 mm thick), also available in a kit.
- Vacuum away any residue produced by the cleaning intervention.
- Rinse with water, taking care NOT to damage the retarder insulating panel.
- Make sure the retarder insulation panel is undamaged and replace it if necessary following the relative procedure.
- After completing the cleaning operations, carefully reassemble the components, following the above instructions in reverse order.
- To close the fixing nuts of the air/gas conveyor assembly, use a tightening torque of 8 Nm.
- Turn the power and gas feeding to the boiler back on.

 If there are stubborn fuel gas deposits on the heat exchanger surface, remove them by spraying with natural white vinegar, taking care NOT to damage the retarder insulating panel.

- Leave it to work for a few minutes.
- Clean the coils of the heat exchanger with a soft bristled brush.

 DO NOT USE METAL BRUSHES THAT COULD DAMAGE THE COMPONENTS

- Rinse with water, taking care NOT to damage the retarder insulating panel.
- Turn the power and gas feeding to the boiler back on.

Cleaning the burner

- Switch off the electricity supply by turning the main system switch OFF.
- Close the gas shut-off valve.
- Remove the casing as explained in paragraph "2.10 Removing the casing".
- Disconnect the connecting cables of the electrodes.
- Disconnect the power cables of the fan.
- Take out the clip (A) of the mixer.
- Loosen the nut of the gas train (B).
- Take out and rotate the gas train.
- Remove the 4 nuts (C) that hold the combustion unit.
- Take out the air/gas conveyor assembly including the fan and mixer, being careful not to damage the ceramic panel and the electrodes. At this point proceed with the burner cleaning operations.
- Clean the burner with a soft bristled brush, taking care not to damage the insulating panel and the electrodes.

 DO NOT USE METAL BRUSHES THAT COULD DAMAGE THE COMPONENTS

- Check that the burner insulating panel and the sealing gasket are undamaged and replace them if necessary, following the relative procedure.
- After completing the cleaning operations, carefully reassemble the components, following the above instructions in reverse order.
- To close the fixing nuts of the air/gas conveyor assembly, use a tightening torque of 8 Nm.
- Turn the power and gas feeding to the boiler back on.

POWER EVO-X 50 DEP - 50

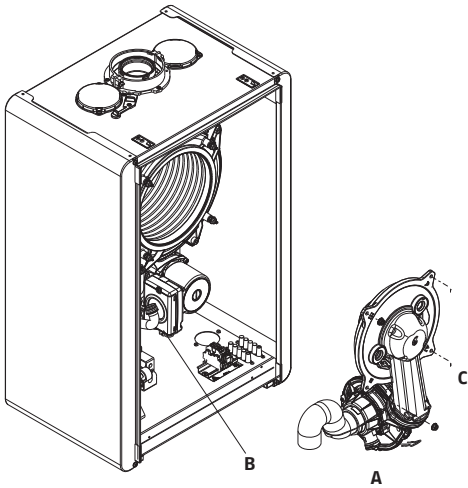

POWER EVO-X 65 - 80

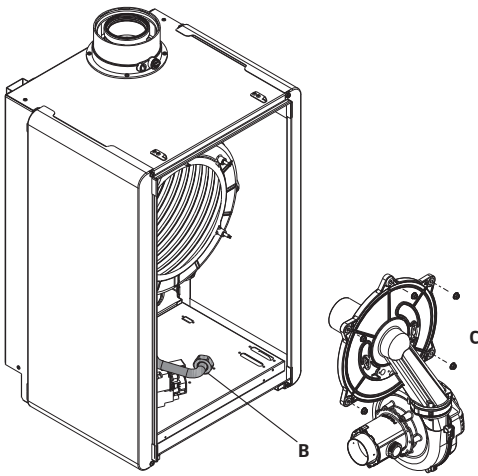

Cleaning the drain-trap

- Disconnect the pipes (A) and (B), take out the clip (C) and remove the drain-trap.
- Loosen the lower and upper plugs, then take out the float.
- Clean the parts of the drain-trap to remove any solid residue.

⚠ Do not remove the float and the relative sealing gasket, as their job is to prevent the leakage of burnt gases in the room if there is no condensate.

⚠ Reposition the previously removed components carefully. Check the float sealing gasket and replace it if necessary. If the float gasket is replaced, make sure the new one is correctly positioned in its seat (refer to the section figure).

⚠ After cleaning, fill the drain-trap with water (see paragraph "3.1 Preliminary checks") before starting up the boiler again.

⚠ After completing the maintenance work on the drain-trap, we recommend running the boiler in condensing mode for a few minutes to check there are no leaks along the entire condensate evacuation line.

⚠ If the appliance has been left unused for more than 60 days, the drain-trap in the boiler must be filled. If the boiler is installed in a place where the ambient temperature may remain above 30°C for long periods, fill the drain-trap after 30 days of non-use. This operation must be carried out by professionally qualified personnel.

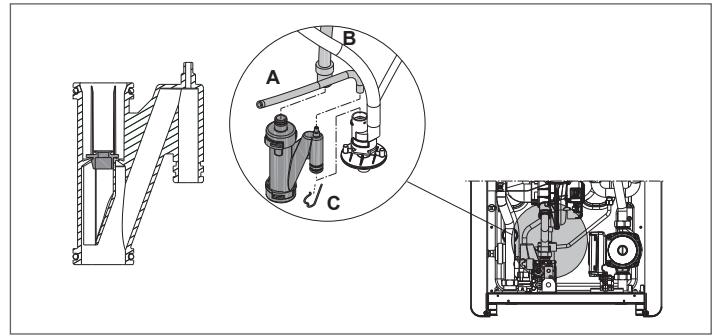

Ionisation electrode

The detector electrode play an important role in the boiler ignition phase and maintaining an efficient combustion; in this regard it is necessary to check its integrity and ensure that it is correctly positioned, strictly respecting the reference position indicated in the figure. If necessary replace it. The same rule applies to the ignition electrode.

A = flame ignition electrode

B = detection electrode

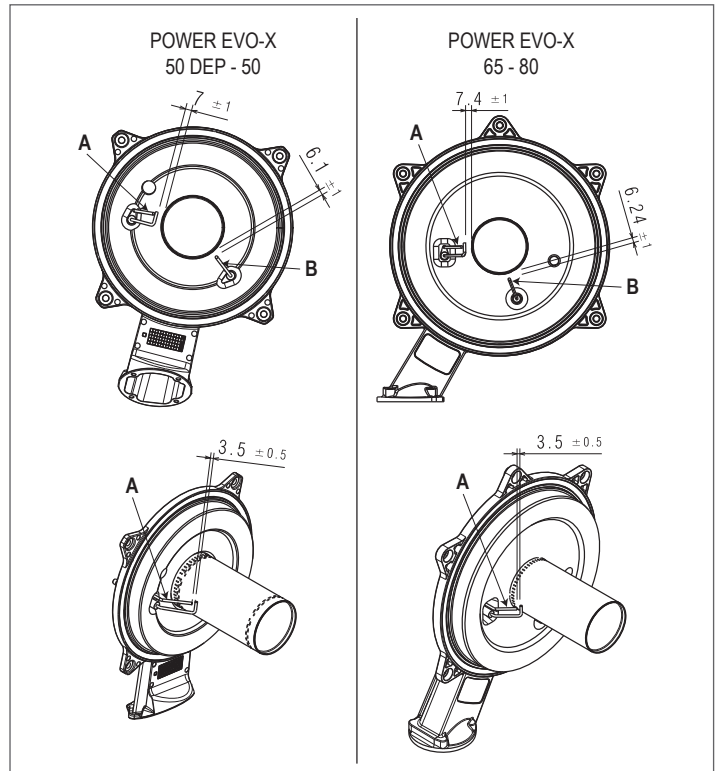

⚠ Do not sandpaper the electrode.

⚠ During the annual maintenance, check the state of wear of the electrodes and replace it if has badly deteriorated.

⚠ The removal and eventual replacement of the electrodes, including the ignition electrode, involves also the replacement of the sealing gaskets.

Non-return valve

The boiler has a check valve.

POWER EVO-X 50 DEP - 50

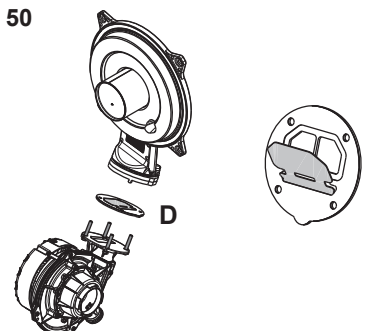

POWER EVO-X 65 - 80

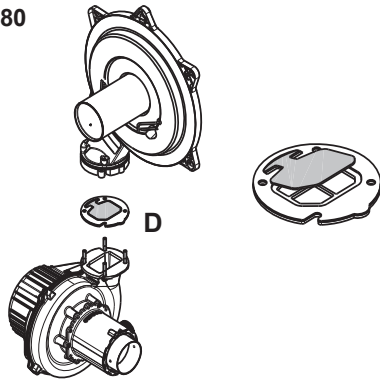

To access the check valve:

- remove the fan by unscrewing the 4 screws (D) fixing it to the conveyor
- make sure there are no foreign material deposits on the membrane of the check valve and if any remove them and checking for damage.
- check the valve opens and closes correctly
- re-assemble the components in reverse order, making sure the check valve is put back in the correct direction.

If maintenance has been carried out on the check valve, make sure it is correctly repositioned to ensure the system operates properly and safely.

4.1 Disassembling the internal components

Disassembling the air-gas conveyor

- Switch off the electricity supply by turning the main system switch OFF.
- Close the gas shut-off valve.
- Remove the casing as explained in paragraph "2.10 Removing the casing".
- Disconnect the connecting cables of the electrodes.
- Disconnect the power cables of the fan.
- Take out the clip (A) of the mixer.
- Loosen the nut of the gas train (B).
- Take out and rotate the gas train.
- Remove the 4 nuts (B) that hold the combustion unit.
- Take out the air/gas conveyor assembly including the fan and mixer, being careful not to damage the insulating panel and the electrodes.
- Check that the burner insulating panel and the sealing gasket are undamaged and replace them if necessary, following the relative procedure.

Removing the ignition electrode, the detector electrode

- Remove the components as described in the chapter "REMOVING THE COMBUSTION UNIT".
- Loosen and remove the screws (W) holding the electrodes.
- The removal and eventual replacement of the electrodes also involves the replacement of the sealing gaskets.
- Once the operations are finished, carefully reassemble all the components, following the above instructions in reverse order.
- Always ensure that the electrodes are positioned correctly and respect the reference position indicated in the figure (maintenance of the ionisation electrode).
- To close the screws fixing the electrodes, use a tightening torque of 2 Nm.
- Once the operations are finished, put back all the components, following the above instructions in the reverse order.
- Turn the power and gas feeding to the boiler back on.

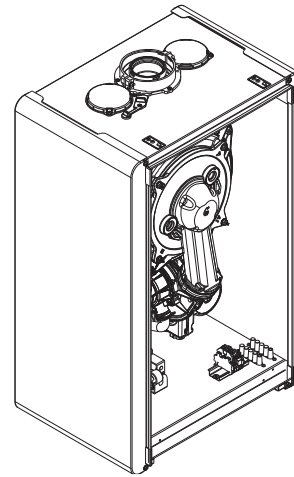

Replacing the burner insulating panel

- Remove the burner insulating panel (A) by inserting a blade just under the surface (as shown in the figure).
- Remove any residual fixing adhesive.
- Fit the new burner insulating panel.
- The new insulating panel does not need to be fixed with an adhesive as its geometric form ensures perfect coupling with the heat exchanger flange.

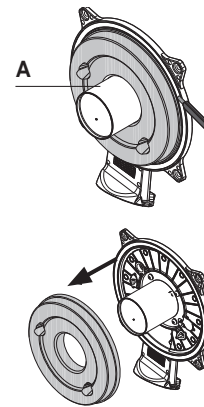

Disassembling the burner

- Switch off the electricity supply by turning the main system switch OFF.
- Close the gas shut-off valve.
- Remove the casing as explained in paragraph "2.10 Removing the casing".
- Remove the insulating panel as explained above.
- Remove the 4 screws (D) fixing the burner to the conveyor, then take it out along with the gasket (E).
- Replace the burner.
- Refit the burner, following the above steps in reverse order and remembering to insert the gasket.
- To close the burner screws fixing use a tightening torque of 3.5 Nm. If the insulation panel is damaged, replace it as described above.
- After completing all the operations, reassemble all the components, following the above steps in reverse order.
- Turn the power and gas feeding to the boiler back on.

POWER EVO-X 50 DEP - 50

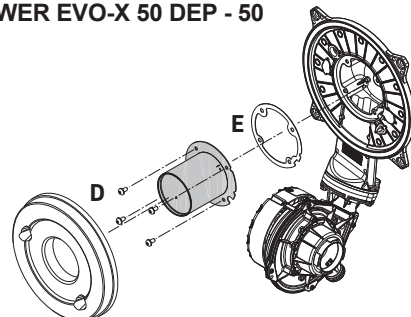

POWER EVO-X 65 - 80

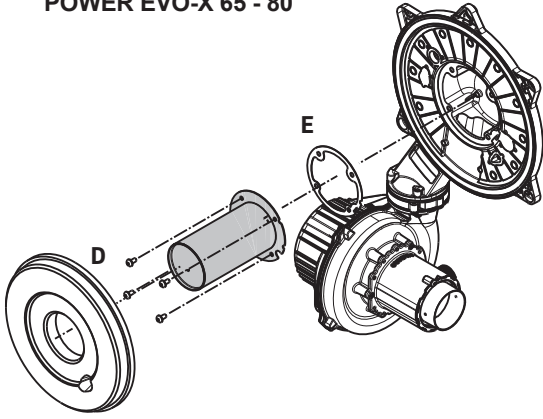

Disassembling the fan and mixer

- Remove the components as explained in "DISASSEMBLING THE COMBUSTION UNIT".
- Completely unscrew the 2 screws (B) and loosen the 2 screws (C) to extract the fan.
- Take out the silencer by releasing it from its support. Loosen the 3 screws (A) fixing the mixer to the fan, then take it out.
- To disassemble the check valve (D), fully loosen the 2 screws (C) as well.
- Once the operations are finished, put back all the components, following the above instructions in the reverse order.
- Turn the power and gas feeding to the boiler back on.

POWER EVO-X 50 DEP - 50

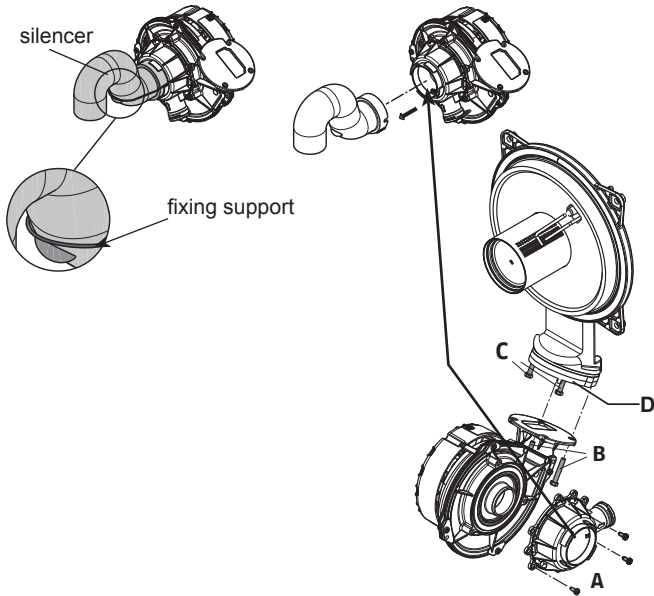

POWER EVO-X 65 - 80

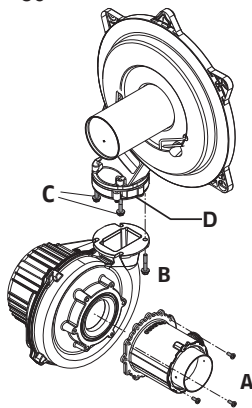

Disassembling the heat exchanger

POWER EVO-X 50 DEP - 50

- Remove the components as described in the chapter "REMOVING THE COMBUSTION UNIT".
- Disconnect the power supply by placing the main switch of the system on "off".
- Empty the system.
- Loosen the nuts of the 2 trains (A and B).
- Take out the clips (C) so you can remove the 2 trains (A and B).
- Take the 2 trains (A and B) out of the heat exchanger.
- Take out the condensate discharge pipe (D).
- Take out the discharge pipe of the rainguard (E).
- Detach the flue gas probe connector.
- Remove the screw (F) of the flue gas analysis outlet, then remove the plug.
- Remove the screw (G) that holds the rainguard in place.
- Loosen the 4 screws (H) that hold the heat exchanger in its seat.
- Take out the heat exchanger.
- Once the operations are finished, put back all the components, following the above instructions in the reverse order.
- Pay special attention when inserting the trains A and B; use pliers at the base of the flaring to prevent an inlet overstroke of the heat exchanger connections.
- Turn the power and gas feeding to the boiler back on.

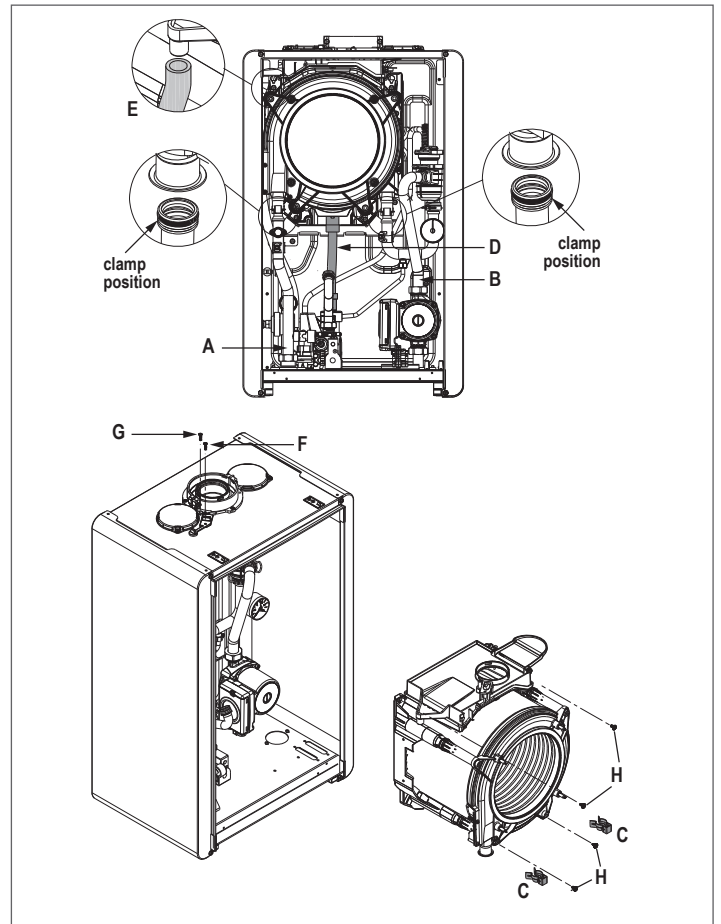

POWER EVO-X 65 - 80

- Remove the components as described in the chapter "REMOVING THE COMBUSTION UNIT".
- Disconnect the power supply by placing the main switch of the system on "off".
- Empty the system.
- Disassemble the right and left side panels (A) by loosening the screws (B).
- Loosen the nut and rotate the gas train (C).
- Take out the silicone pipes (D) and (E).
- Take out the train (F).
- Take the condensate discharge pipe out of the heat exchanger (G).
- Take out the clip (H).
- Loosen the nut and take out the train (I).
- Disconnect the circulator wiring, take out the probe and loosen the 2 nuts.

- Raise the upper nut (L).
- Lower the bottom nut (M).
- Take out the upper train.
- Take out the circulator (N).
- Loosen the 4 screws (O) that hold the heat exchanger in place.
- Take out the heat exchanger (P).

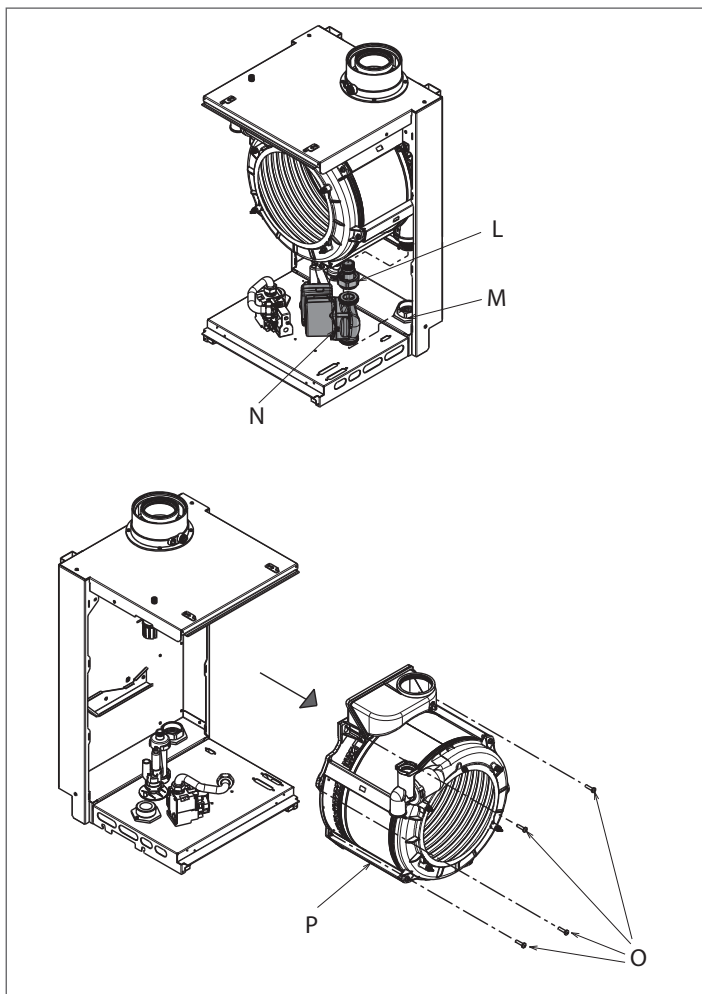
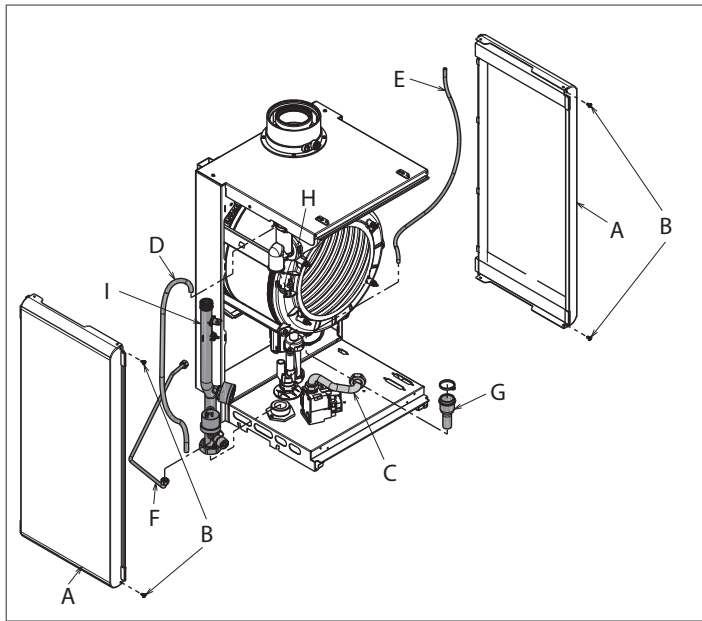

Disassembling the circulator

- Disconnect the power supply by placing the main switch of the system on "off".
- Empty the system.
- Disassemble the right side panel (A) by loosening the 2 screws (B)
- Loosen the nut and rotate the gas train (C)
- Loosen the 4 screws (D) and take out the combustion door with the fan and mixer (E)
- Loosen the nuts holding the train (F) in place, then take it out
- Loosen the nuts (G)
- Take out the circulator (I) and the train (E).

⚠ Refit the circulator, making sure it is in the same position as before and does not interfere with the fan.

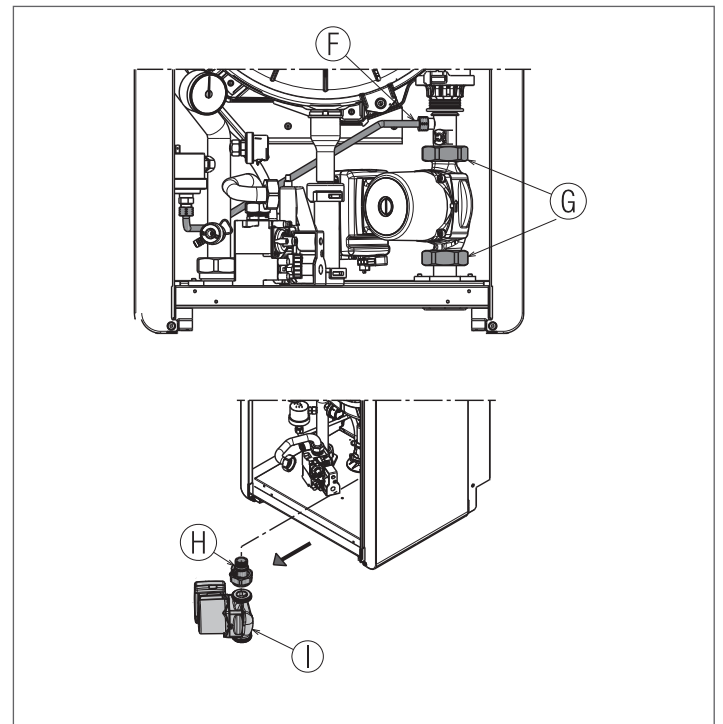
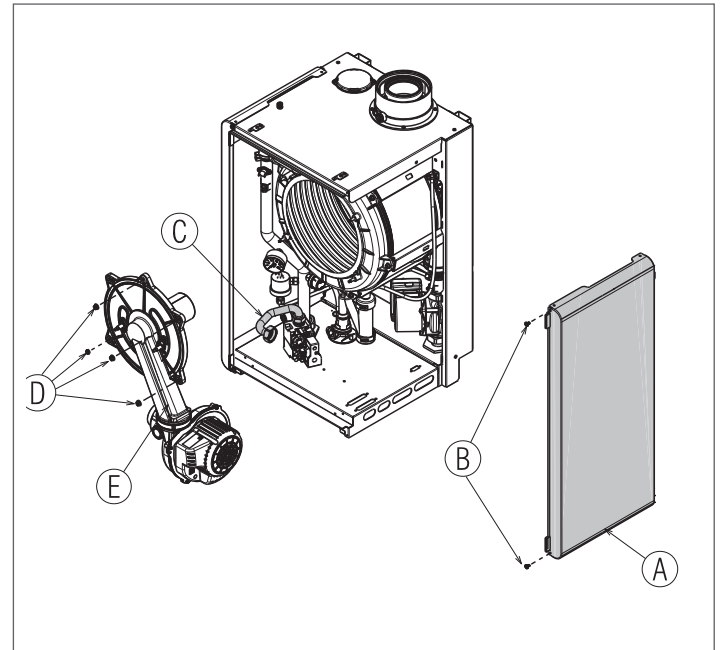

Via Risorgimento, 23 A
23900 - Lecco

www.berettaheating.com

The manufacturer strives to continuously improve all products. Appearance, dimensions, technical specifications, standard equipment and accessories are therefore liable to modification without notice..

