

REMOTE CONTROL

EN INSTALLATION AND MAINTENANCE MANUAL

RANGE

MODEL	CODE
REMOTE CONTROL	20132366

ACCESSORIES

For a complete list of accessories and details of their compatibility, refer to the Catalogue.

Dear heating engineer,
we congratulate you on proposing the accessory **REMOTE CONTROL**.

While your technical skills and knowledge will certainly be more than sufficient, this booklet contains all the information that we have deemed necessary for the device's correct and easy installation.

Please accept our thanks and our congratulations on your choice of product.

CONFORMITY

The REMOTE CONTROL panels comply with:

- Electromagnetic Compatibility Directive 2014/30/EU
- Low Voltage Directive 2014/35/EU



At the end of its life, the product should be not be disposed of as solid urban waste, but rather it should be handed over to a differentiated waste collection centre.

CONTENTS

1	GENERAL INFORMATION	4
1.1	General Safety Information	4
1.2	Precautions	4
1.3	Description of the appliance	4
2	INSTALLATION	5
2.1	Unpacking the product	5
2.2	Assembly	5
2.3	Wiring diagram	6
2.4	Electrical connections	6
3	MODBUS CONNECTION	7
4	COMMISSIONING AND MAINTENANCE	11
4.1	Electronic control	11
4.2	Initial startup	12
4.2.1	Date and time setting	12
4.2.2	Password access	13
4.2.3	PB setting	13
4.2.4	Scheduled programme	13
5	SETTING PARAMETERS OF THE ADDITIONAL ZONE	16
5.1	Setting zone parameters (accessible only with installer password)	16
5.1.1	Menu structure	17
5.2	Setting zone's climatic curve parameters (accessible only with installer password)	19
5.3	Programming the zone	19
5.4	Scheduling the time bands	20
5.5	Information on the operation of the zone	20
5.5.1	Zone control with Depending module	21
5.5.2	Deleting dependent zone	21
5.6	Controlling zone with additional zone accessory	22
5.7	Error List	23
5.7.1	Permanent Errors	23
5.7.2	Temporary Errors	24
5.7.3	Warnings	26
6	RECYCLING AND DISPOSAL	27





The following symbols are used in this manual:

 **CAUTION!** = Identifies actions that require caution and adequate preparation.







 **STOP!** = Identifies actions that you MUST NOT do.

1 GENERAL INFORMATION

1.1 General Safety Information

-  After having removed the package, be sure to verify the integrity and the completeness of the consignment, and contact the Agency from which the device was purchased if any discrepancies are encountered.
-  The product's installation must be carried out by an authorised company that will issue a declaration of the installation's conformity to the product's owner once the work has been completed, indicating that the work has been carried out in accordance with the standards of good practice, the current National and Local regulations, and the indications provided by the manufacturer in the instruction booklet accompanying the device.
-  The product must be used for its intended purpose (as described by the manufacturer) for which it has been expressly manufactured. The manufacturer shall bear no responsibility, whether of a contractual or non-contractual nature, for any damage caused to people, animals, or property due to incorrect installation, adjustments, or maintenance, or improper use.
-  This instruction sheet is an integral part of the booklet of the equipment on which the accessory is installed. Please refer to said booklet for GENERAL WARNINGS and ESSENTIAL SAFETY REGULATIONS.

1.2 Precautions

-  Never clean the boiler without first disconnecting it from the mains electricity supply by turning the mains power switch and the control panel switch OFF.
-  Never pull, disconnect, or twist the electrical cables coming from the appliance even if it is disconnected from the mains electricity supply.
-  All maintenance and repairs must be carried out by a legally qualified heating engineer.
-  Do not use water to extinguish fire in the control panel. Switch power OFF at the mains power switch to isolate the control panel electrically first. Then use a class E fire extinguisher (marked "SUITABLE FOR LIVE ELECTRICAL ITEMS") to extinguish the flames.
-  Do not dispose of packaging material into the environment, or leave it within the reach of children, since it can become a potential hazard. Dispose of packaging material in compliance with applicable legislation.
-  Do not allow children or infirm persons to operate the system unsupervised.
-  It is forbidden to touch the device while barefoot or with wet or moist body parts.

1.3 Description of the appliance

The **REMOTE CONTROL** is a communication interface that connects up directly to the bus output on the thermal unit. It is used for time programming. When used together with the electronic device for managing zones it can be used to manage direct or mixed zones.

2 INSTALLATION

2.1 Unpacking the product

The REMOTE CONTROL is supplied packed in a cardboard box identified with a label that bears the name, the numeric code and the barcode of the product.

⚠ The instruction booklet is an integral part of the accessory, and should therefore be carefully read and stored in a safe location.

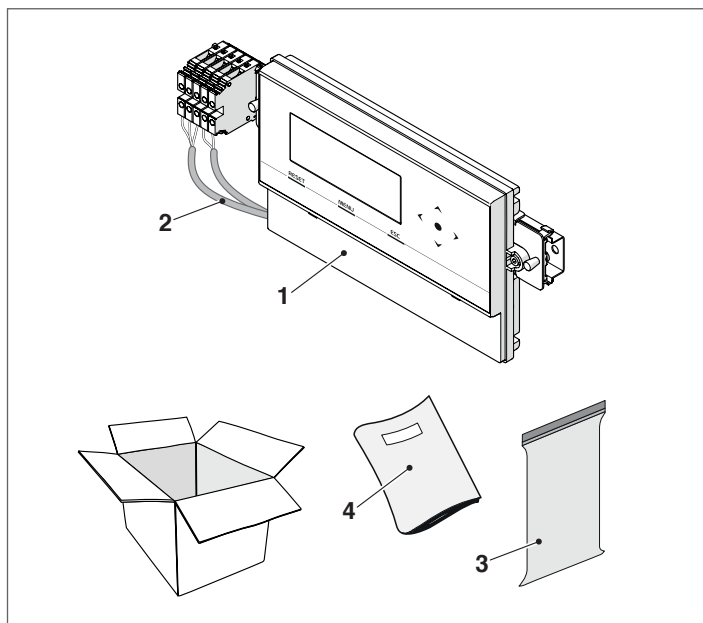

Ref.	Description	Q.ty
1	Remote control	1
2	Cables	1
3	Transparent bag	1
4	Instructions sheet	1

2.2 Assembly

The REMOTE CONTROL is designed to be installed on a wall-mounted or recessed electrical panel or switchboard (not supplied) using a 35 mm DIN rail - W. 305 mm (18 DIN modules).

⚠ It is possible to connect a single remote control device for a single boiler or for a cascade system.

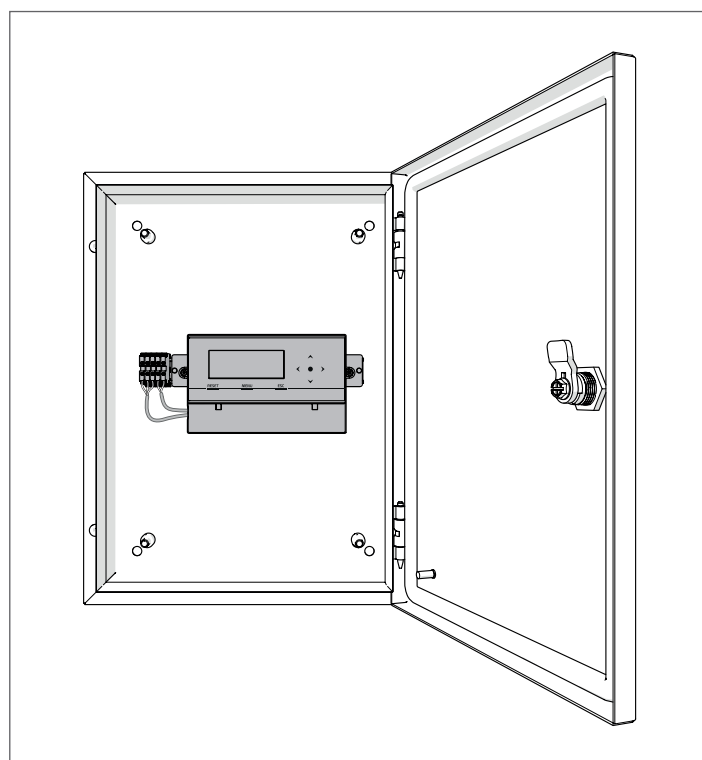
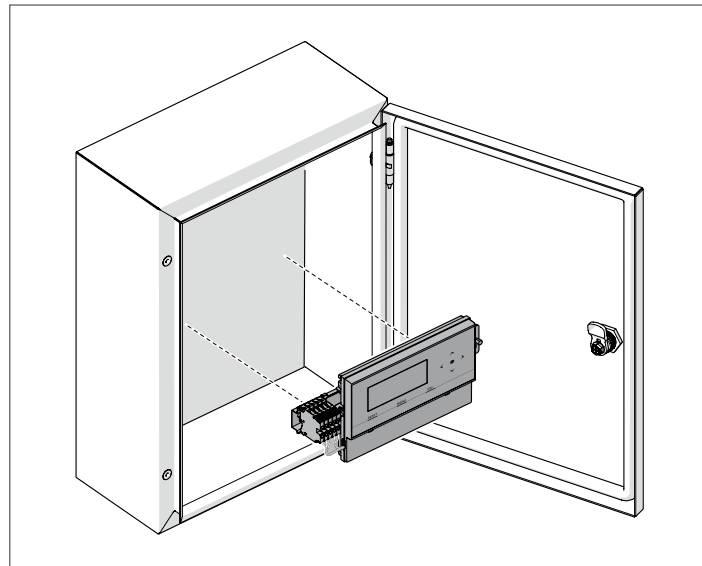

2.3 Wiring diagram

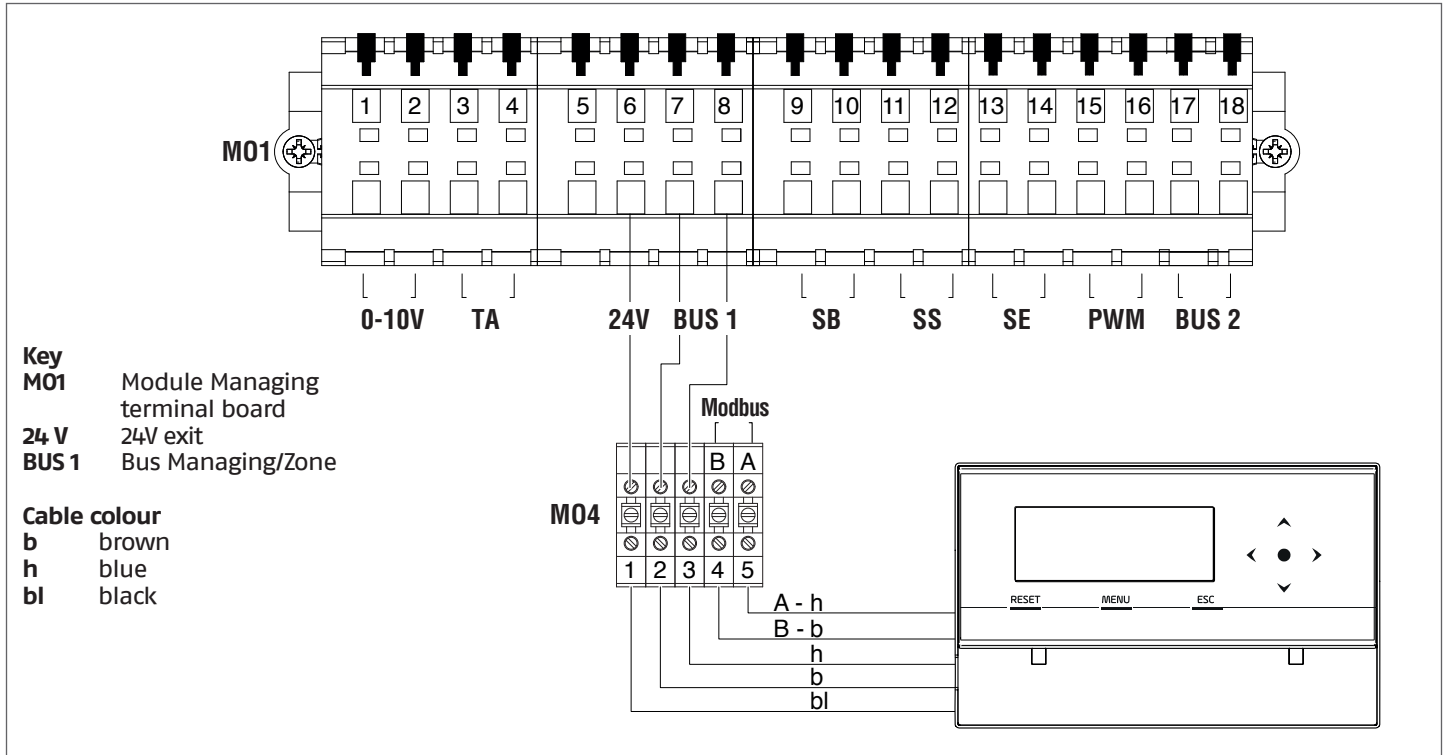

2.4 Electrical connections

Connections to be provided by installer

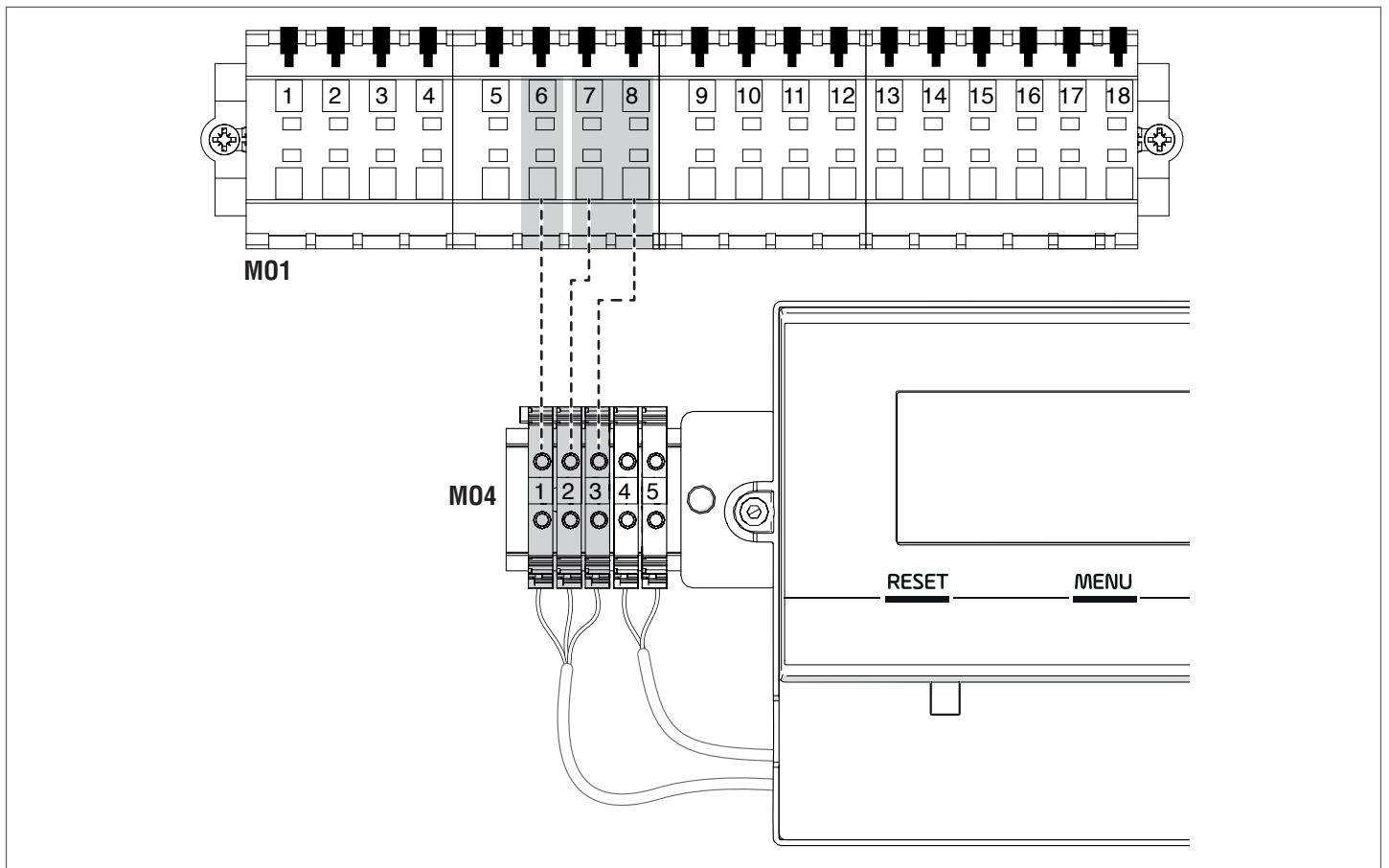

⚠ Electrical power cables and those for signals (room/heat request thermostat, outdoor temperature sensors, etc.) must be strictly separate from one another and installed inside independent ribbed PVC piping up to the electrical panel.

3 MODBUS CONNECTION

The remote control is equipped with a Modbus connection (based on the RS485 communication standard) that supports the remote management and adjustment of the remote thermal module or the cascade system. The modbus connection is in the terminal board of the remote control accessory.

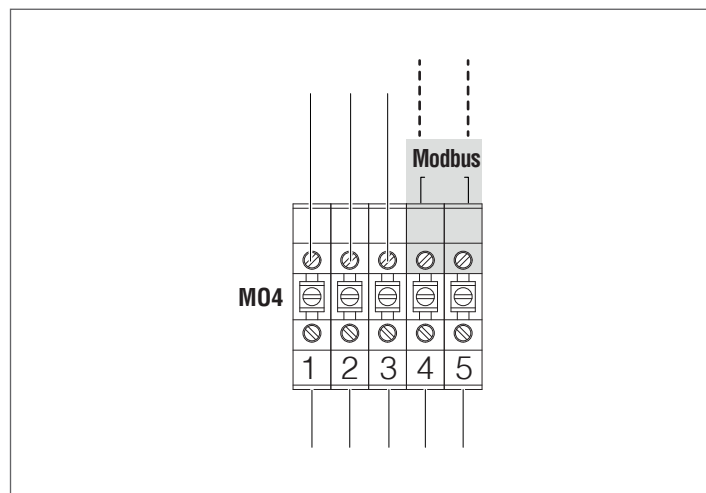

Configuration

The following table shows the connection details.

Protocol	Modbus RTU
Slave address	Adjustable from the display. Default: 1
Supported Modbus controls	Read Holding registers (03) Write single holding register (06) Write multiple holding registers (10)
Baud rate	9600 bps.
Length	8
Parity	No
Stop Bits	1 or 2 (adjustable from PB or PC software)
Connection	RS485 (2 wires + optional earthing)

As shown in the table above, the thermal module's address (meant as the address of the slave device in the Modbus system) and the number of "Stop Bits" are two adjustable values. To modify one or the other, from the home screen, access the "Settings" menu, select "General settings" and confirm.



Access the "Other settings" menu and select "Modbus Address"

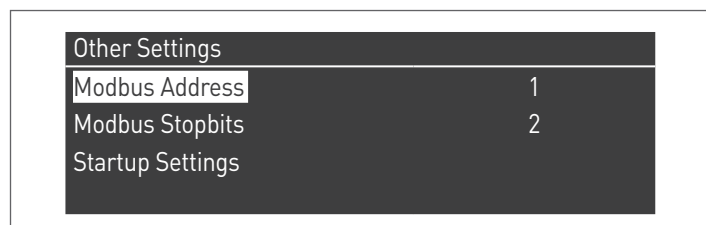

Registers

Depending on the type of Modbus device used to connect to the thermal module, the registers' addressing may start from 0x0000 or 0x0001.

If addressing starts from 0x0000, the numbers of the registers listed in the table below may be used directly for reading/writing operations; if addressing starts from 0x0001, the numbers of registers shown in the table, plus one, must be used for reading/writing operations.

Control register

The control register is used for special functions. The first one is that of enabling writing on registers. All accessible registers, including write ones, must be first enabled to receive data. To prevent undesired entries, it is possible to change the value in a register only during the first four seconds after the status change of the 0 bit in the control register. Therefore, before changing the value of a register, it is necessary to change the status of 0 bit of the control register (register No. 99), sending the string 1 to it.

The control register also supports the remote resetting of the board, by changing the status of the 14 bit. Therefore, by sending the value 16384 to register No. 99, it is possible to reset the board.

! By sending a value other than 1 and from 16384 to register No. 99, the latter will return to the write-protected status (bit 0=0).

The table that summarises the control register's operation is provided below:

Register number	Access	Access		Description	Value range
		L	S		
99	0063	X	X	Control register	Bit 0: enables writing Bit 14: controller reset

Measurement unit selection register

Register 98 is used to change the format of the data stored in registers (those containing temperature or pressure values). Before changing the value of the selection register, it is necessary to enable it for writing by forwarding the enabling command to the 99 control register.

The table for measurement unit selection register is the following:

Register number	Access	Access		Description	Value range
		L	S		
98	0062	X	X	Measurement unit selection register	Bit 0: °C/°F Bit 1: bar/psi

Types of data

Type of data	Unit
Temperature	°C/°F
Voltage	Volt
Pressure	bar/psi
Ionisation current	µA
Percentage	%
Connection	RS485 (2 wires + optional earthing)

Status parameters

Register number	Access		Description	Automatic conversion	Value range
	L	S			
100	X		State		See "State" table
101	X		Status		Same "State" value
102	X		Error code		See "Error" tables
110	X		Heating pump		0=off; 1=on
111	X		DHW pump		0=off; 1=on
112	X		Module pump		0=off; 1=on

NOTE: alarms occur according to the type of boiler installed.

Temperatures/Information

Register number	Access		Description	Automatic conversion	Value range
	L	S			
120	X		Delivery temperature	Yes	Depends on °C/°F units
121	X		Return temperature	Yes	Depends on °C/°F units
122	X		DHW temperature	Yes	Depends on °C/°F units
123	X		Flue gas temperature	Yes	Depends on °C/°F units
124	X		System temperatures (where available)	Yes	Depends on °C/°F units
125	X		Outdoor temperature (where available)	Yes	Depends on °C/°F units
140	X		Power	Yes	0..100%
142	X		Ionisation current	Yes	0..x µA

Dependent information

Register number	Access		Description	Automatic conversion	Value range
	L	S			
Dependent 01					
300	X		State		See "State" table
302	X		Error code		See "Error" tables
303	X		Power	Yes	0..100%
Dependent 02					
306	X		State		See "State" table
308	X		Error code		See "Error" tables
309	X		Power	Yes	0..100%
Dependent 03					
312	X		State		See "State" table
314	X		Error code		See "Error" tables
315	X		Power	Yes	0..100%
Dependent 04					
318	X		State		See "State" table
320	X		Error code		See "Error" tables
321	X		Power	Yes	0..100%
Dependent 05					
324	X		State		See "State" table
326	X		Error code		See "Error" tables
327	X		Power	Yes	0..100%
Dependent 06					
330	X		State		See "State" table
332	X		Error code		See "Error" tables
333	X		Power	Yes	0..100%
Dependent 07					
336	X		State		See "State" table
338	X		Error code		See "Error" tables
339	X		Power	Yes	0..100%
Dependent 08					
342	X		State		See "State" table
344	X		Error code		See "Error" tables
345	X		Power	Yes	0..100%

Register number	Access		Description	Automatic conversion	Value range
	L	S			
Dependent 09					
348	X		State		See "State" table
350	X		Error code		See "Error" tables
351	X		Power	Yes	0..100%
Dependent 10					
354	X		State		See "State" table
356	X		Error code		See "Error" tables
357	X		Power	Yes	0..100%
Dependent 11					
360	X		State		See "State" table
362	X		Error code		See "Error" tables
363	X		Power	Yes	0..100%
Dependent 12					
366	X		State		See "State" table
368	X		Error code		See "Error" tables
369	X		Power	Yes	0..100%
Dependent 13					
372	X		State		See "State" table
374	X		Error code		See "Error" tables
375	X		Power	Yes	0..100%
Dependent 14					
378	X		State		See "State" table
380	X		Error code		See "Error" tables
381	X		Power	Yes	0..100%
Dependent 15					
384	X		State		See "State" table
386	X		Error code		See "Error" tables
387	X		Power	Yes	0..100%

Parameters registers

Register number	Access		Description	Note	Automatic conversion	Value range
	L	S				
500	X	X	Heating mode (Par. 1)	NV		0..x
501	X	X	DHW mode (Par. 35)	NV		0..x
502	X	X	Heating set-point (Par. 3)	V	Yes	Depends on °C/°F units
503	X	X	DHW set-point (Par. 48)	V	Yes	Depends on °C/°F units
504	X	X	Set-point at min. climatic T (Par. 19)	NV	Yes	Depends on °C/°F units
505	X	X	Set-point at max. climatic T (Par. 21)	NV	Yes	Depends on °C/°F units
506	X	X	Out. temperature for climatic minimum (Par. 22)	NV	Yes	Depends on °C/°F units
507	X	X	Out. temperature for climatic maximum (Par. 20)	NV	Yes	Depends on °C/°F units
508	X	X	Climatic shut-off (Par. 25)	NV	Yes	Depends on °C/°F units
509	X	X	Maximum value that can be assigned to the heating set-point (Par. 24)	NV	Yes	Depends on °C/°F units

Register number	Access		Description	Note	Automatic conversion	Value range
	L	S				
510	X	X	Minimum value that can be assigned to the heating set-point (Par. 23)	NV	Yes	Depends on °C/°F units
511	X	X	Night-time attenuation (Par. 28)	NV	Yes	Depends on °C/°F units
512	X	X	Extra primary setpoint for DHW (Par. 38)	NV	Yes	Depends on °C/°F units

In the "Note" column, the registers marked with "V" can be written on an ongoing basis (and be used for dynamic size control). Registers marked with "NV", on the other hand, can be overwritten only for a limited number of times (around 10,000 times with an average of twice a day).

Service reminder

Register number	Access		Description	Automatic conversion	Value range
	L	S			
1500	X		Hours elapsed from the last maintenance activity		0...65534 hours
1501	X		Hours from the next maintenance activity		.. 0...maintenance intervals
1504	X		Counter delay index		0...14
1505	X		Delay counter 0		0...65534 hours
1506	X		Delay counter 1		0...65534 hours
1507	X		Delay counter 2		0...65534 hours
1508÷1518	X		Delay counter 3÷13		0...65534 hours
1519	X		Delay counter 14		0...65534 hours

Register number	Access		Description	Automatic conversion	Value range
	L	S			
1540	X	X	Service reminder reset		0...1 (1=reset)
1541	X	X	Setting the hour counting mode for logs 33000-33001		0= burner ON hours counted 1= boiler ON hours counted
1542	X	X	Maintenance interval hours		0..25500 hours (in steps of 100)

Note: If a counter shows the value 65535, this means that either it is inactive or has exceeded the limit value.

STATUS table

Nr.	Name	Description
0	STANDBY	Standby
10	ALARM	Non-volatile lockout error
14	BLOCK	Volatile lockout error
15	FROST_PROTECT	Frost protection on
16	CH_DEMAND	Heat demand
17	RESET_STATE	Reset
18	STORAGE_DEMAND	DHW demand
19	DHW_TAP_DEMAND	Imm. DHW demand.
20	DHW_PRE_HEAT	Pre-heating demand
21	STORE_HOLD_WARM	Holding desired storage temperature
22	GENERAL_PUMPING	General pump ON

STATE table

Nr.	Description
0	Initialisation
1	Reset
2	Standby
3	Pre-wash
4	Pre-wash
5	Pre-ignition
6	Pre-ignition
7	Flame detection test
8	Burner ON
9	Burner ON
10	Post-purging
11	Post-purging
12	Volatile lockout error
13	Non-volatile lockout error

4 COMMISSIONING AND MAINTENANCE

4.1 Electronic control

The electronic control operator interface menu is a multi-level one.

Navigation between the various levels is shown in the figures below.

Level 0 displays the Home Screen (Home). Level 1 displays the Main Menu". The subsequent levels are activated depending on available sub-menus. For the full layout, see Paragraph "Control panel". For how to access and change the parameters, see the picture on the next page. The parameters for the installer are accessible only after entering the security password (see paragraph "Control panel").

Please note that the thermal module's operating parameters are identified with a number, whilst other additional functions are simply descriptive.

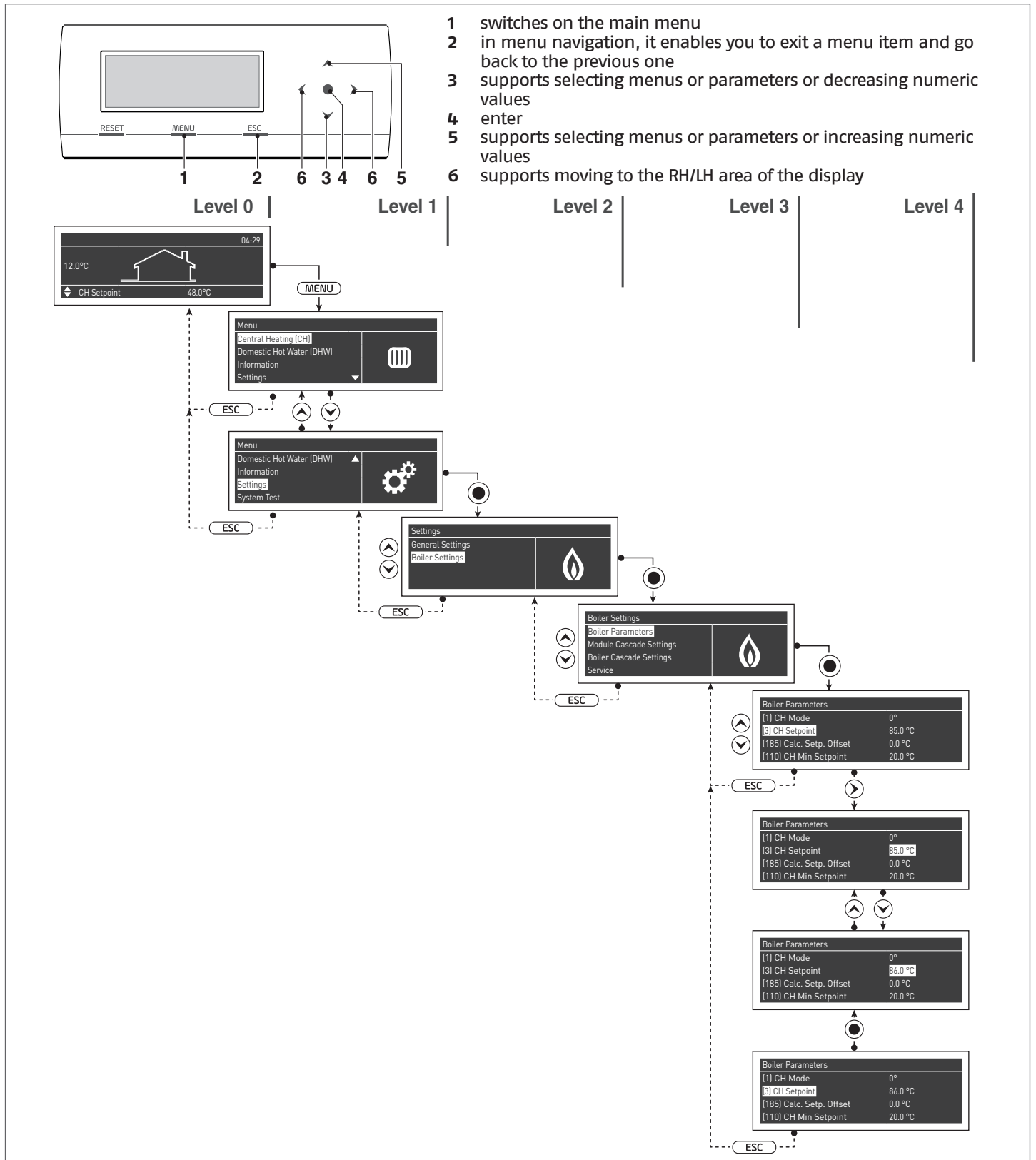

4.2 Initial startup

4.2.1 Date and time setting

Press the MENU key and select "Settings" with the ▲ / ▼ keys

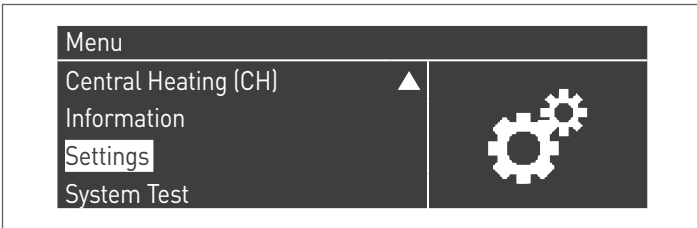

Confirm with the ● key and select "General settings" with the ▲ / ▼ keys



Confirm with the ● key and select "Date and Time " with the ▲ / ▼ keys



Press the ● key, the display will be shown as follows:

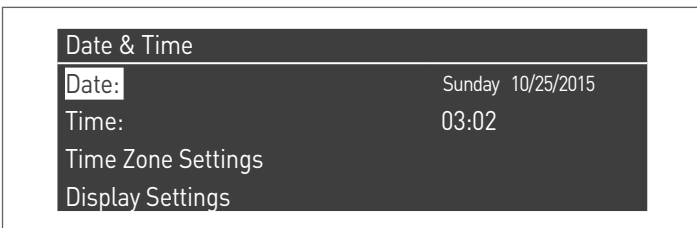

Press the ● key to highlight the values.

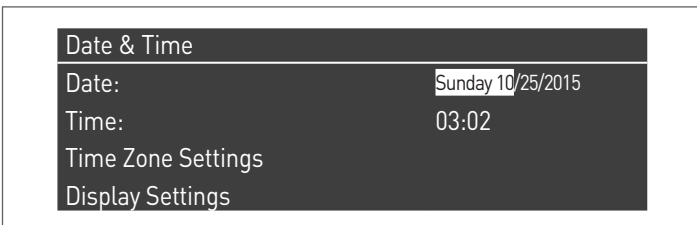

Values can be changed with the ▲ / ▼ keys. Confirm the value entered pressing the ● key and move to the next value.

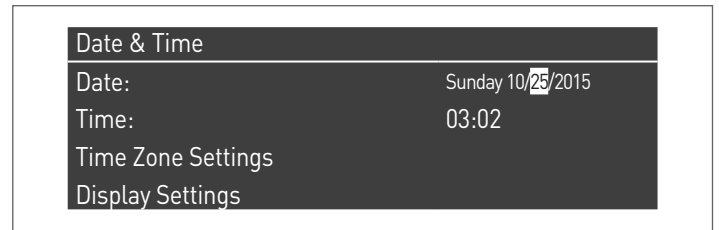

To set the time, follow the same procedure.

By accessing the "Time Zone Settings" menu, it is possible to set the time zone parameter as shown in the figure below:

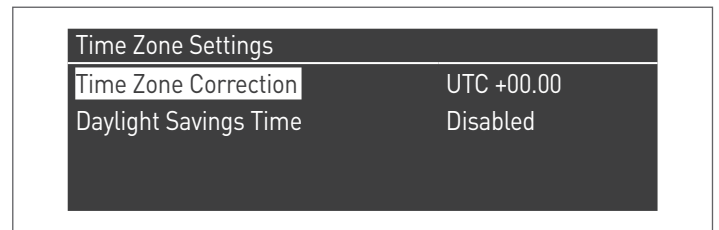

To change the way in which date and time are displayed, it is possible to change the following characteristics by accessing the "Display Settings" menu:

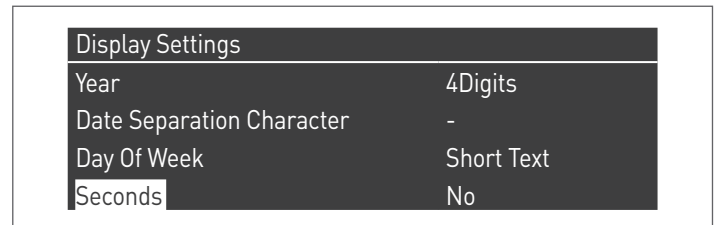
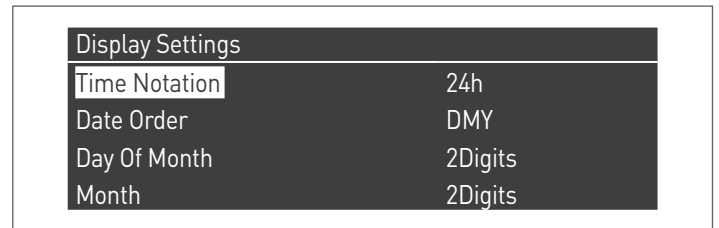

4.2.2 Password access

To access the parameters, press the MENU key and select "Settings" with the ▲ / ▼ keys.

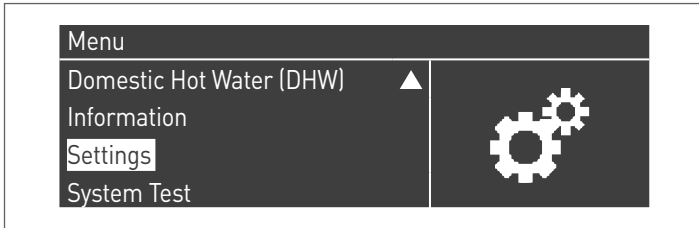

Confirm with the ● key and select "Boiler settings" with the ▲ / ▼ keys

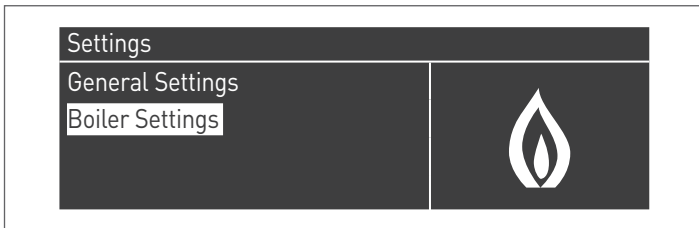

Press the ● key to confirm.

- The system will now ask you to enter a password (the password is required for thermal module settings only):

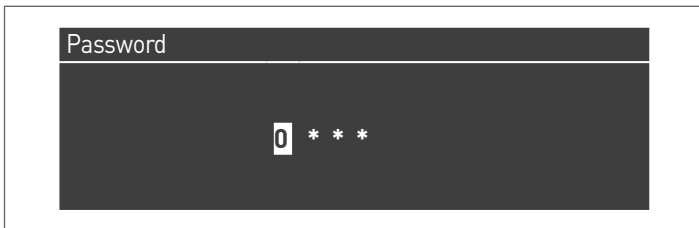

4.2.3 PB setting

Select RC mode to enable external zone management and set the time programme.

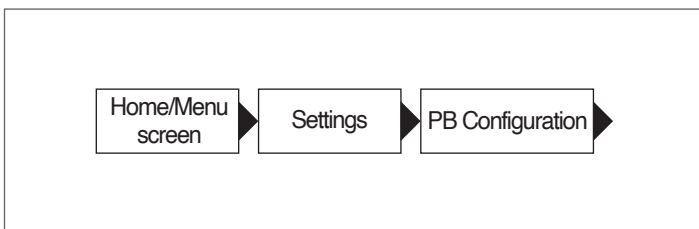

4.2.4 Scheduled programme

The Scheduled Programme is designed to program the operation of the various circuits managed by the thermal module, (CH, DHW and additional mixed zones).

Seasonal Programme

The Seasonal Programme is use to exclude additional mixed zones during the summer season. It does not control any DHW parameter.

Holiday Programme

The Holiday Programme is used to exclude part of or all the circuits at a certain time of the year.

A holiday can be set both on the full system and on various groups of circuits.

The group system enables the user to add various circuits to the group to set a holiday period for several circuits at the same time. (For instance, to manage a semi-detached house with a centralised heating system when one of the two families is on holiday and the other is not).

The set-point type can be adjusted so as to correspond to the desired setting.

The system can control up to a total of 16 "Mixed" zones. The programming of mixed areas is only allowed with an accessory. At the same time as these 16 areas, it is also possible to enable the CH zone (direct zone for central heating only).

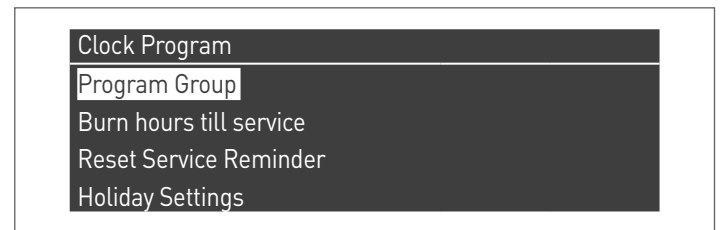

The time programme includes the following parameters:

Group Programming

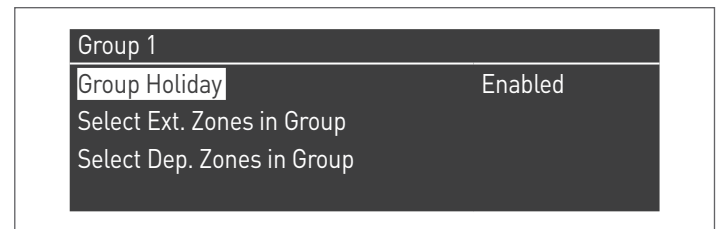

It enables the user to select a group to add zones to the selected group. It also enables the user to enable/disable the group in question.

Group settings are used to add zones to the groups.

The "Group programming" menu enables the use to chose among 8 groups. Each of them can be enabled or disabled.

Within it, it is possible to select zones to be added to the group (direct zone (CH) - mixed zones from 1 to 16)

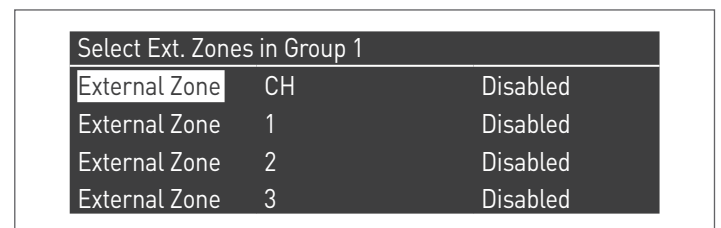

N.B. The programming of mixed areas is only allowed with an accessory.

Heating programming

Group 1	
Program Comfort Period	1
Comfort Setpoint	28.0 °C
ECO Setpoint	20.0 °C
Out of interval setpoint	Reduced

It supports adjusting the time programme for the CH zones with the following parameters:

Period setting

Enables the user to select a period from 1 to 7. Period settings enable the user to adjust the active periods for this zone.

- **Active days:** Selection of the day (s) on which the period is active. Enables the user to disable the period set for one or more days. When this parameter is set as inactive, the other items on this menu are no longer used and hidden from the view. The choice of active days is between the following macro-groups: Sat-Sun, Mon-Fri, Mon-Sun, or individual days: Mon, Tue, Wed,...
- **Interval 1 (hidden if Active Days is disabled):** This parameter allows the user to regulate the starting and end time of the period. The starting time must always be before the finishing time.
- **Interval 2 (hidden if Active Days is disabled):** Same as interval 1. Interval added for the activated period.
- **Interval 3 (hidden if Active Days is disabled):** Same as interval 1. Interval added for the activated period.

External Zone CH - Period 1		
Active Day(s)	Sunday	
Interval 1	00:00	00:00
Interval 2	00:00	00:00
Interval 3	00:00	00:00

Comfort Set-point

Comfort temperature to be used when the zone is in a certain period. (10 -30 °C).

ECO set-point

ECO temperature. Adjustable temperature that can be used outside set periods (5 - 20 °C).

Set-points outside the interval

Selection of the type of set-point to be used when a zone is not on a set period by selecting between:

- Off
- Comfort
- Eco
- Anti-Freeze (is activated below 5°C NON-ADJUSTABLE)
- Reduced (Calculated as -10°C Comfort Set-point value)

DHW setting

Group 1	
Program Comfort Period	1
Out of interval setpoint	On

It supports adjusting the time programme for the DHW zone.

Period setting

Enables the user to select a period from 1 to 7. Period settings enable the user to adjust the active periods for this zone.

- **Active days:** Selection of the day (s) on which the period is active. Enables the user to disable the period set for one or more days. When this parameter is set as inactive, the other items on this menu are no longer used and hidden from the view. The choice of active days is between the following macro-groups: Sat-Sun, Mon-Fri, Mon-Sun, or individual days: Mon, Tue, Wed,...
- **Interval 1 (hidden if Active Days is disabled):** This parameter allows the user to regulate the starting and end time of the period. The starting time must always be before the finishing time.
- **Interval 2 (hidden if Active Days is disabled):** Same as interval 1. Interval added for the activated period.
- **Interval 3 (hidden if Active Days is disabled):** Same as interval 1. Interval added for the activated period.

External Zone DHW - Period 1		
Active Day(s)	Sunday	
Interval 1	00:00	00:00
Interval 2	00:00	00:00
Interval 3	00:00	00:00

Set-points outside the interval

Selection of the type of set-point to be used when a zone is not on a set period by selecting between:

- Off
- On

Holiday setting

Holiday Settings	
Mode	Group
Group	1

Enables the user to change parameters for the Holiday Programme.

Mode

Select the Holiday programme mode. It can be set to Off, System or group.

Off

Disabled programme

Group

it enables the selection of the group (1 – 8).

As part of group selection, the Holiday Group is displayed with the following parameters:

- **Holiday set-point:** Set-point type to be used for the selected group. All zones in this group shall use this set-point if the current date is between the start and end date of the holiday period, but only if the group is enabled in the group settings menu, and can be selected from: Off, Comfort, Eco, Anti-freeze and Reduced.
- **Start date / End date (Day DD-MM-YEAR):**

External Zone DHW - Period 1		
Active Day(s)	Sunday	
Interval 1	00:00	00:00
Interval 2	00:00	00:00
Interval 3	00:00	00:00

- **System:** It enables the user to select the holiday programme for the entire system. In this mode, the set-point is common to all system groups.

External Zone DHW - Period 1		
Active Day(s)	Sunday	
Interval 1	00:00	00:00
Interval 2	00:00	00:00
Interval 3	00:00	00:00

- **Holiday set-point (hidden if the Mode is set to "Off"):** Type of reference to be used when system mode is selected. This set-point is used for all areas. Only used for the holiday system.

Seasonal setting

Enables the user to change parameters for the Seasonal Programme.

The seasonal programme is used to define a period of inactivity for the heating system. This menu includes the following elements:

Activates heating basis

Selects how the seasonal programme must verify whether heating can be allowed or not. It can be set on:

- **Always:** it means that the seasonal programme is ignored and (CH) heat demand is always allowed throughout the year.

Season Settings	
Mode	Off

- **At date:** excludes heating (CH+zone) when the current date is included between the start and the end dates.

Season Settings	
Mode	On Date
Begin Date	15-04
End Date	15-09

- **At Temp:** excludes heating (CH+zone) when the outdoor temperature is higher than the selected temperature. (Ext. deactivation T: 0.0 °C/50 °C)

Season Settings	
Mode	On Temp
Outdoor Temp. Below	25.0 °C

5 SETTING PARAMETERS OF THE ADDITIONAL ZONE

Controls interface

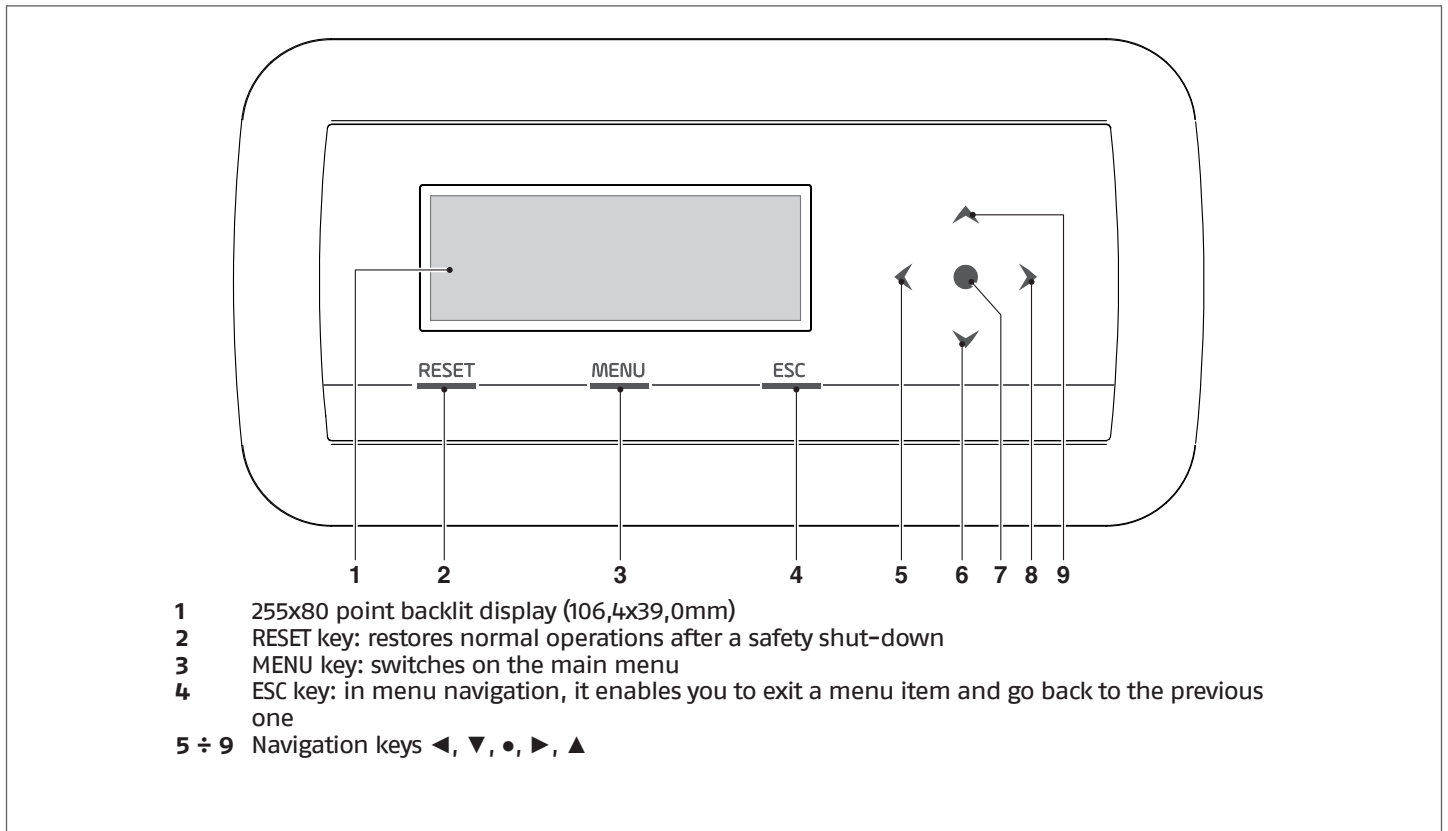

5.1 Setting zone parameters (accessible only with installer password)

Menu → "Settings" → "Zone Config."

This menu allows you to separately set the parameters of all the connected zones with the exception of the "Extra setpoint zone" which is the same for all zones.

To select the zone for controlling/changing the parameters, proceed as follows:

- press the ▶ key so that the number to the right of "zone" is highlighted;
- once the number is highlighted use the ▲ and ▼ keys to change the number of the zone;
- once the zone is selected, confirm with the • key.

The zone parameters are the following:

Description	Standard value that is set	Range	Explanation	UM
Post-circ. Zone Pump	120	0-255	Establishes the time in seconds of the post-circulation	Secs
Mix Valve Max Op/Cl Time	25	0-255	Fixes the time in second of the total opening/closing of the mix valve (valid for three point mix valve)	Secs
Mix Valve Max steps	700	0-65535	Fixes the number of steps for the total opening of the mix valve (valid for step-by-step mix valve)	
PID zone mode	Symmetrical	Symmetrical/Asymmetrical	Fixes the PID control mode	
PID P Zone	10	0-255	Proportional parameter for the valve control	
PID I Zone	150	0-255	integrative parameter for the valve control	
PID D Zone	0	0-255	Derivative parameter for the valve control	
Extra zone setpoint	10	0-30	Establishes the increase for the primary setpoint with respect to the zone setpoint	°C

⚠ For more information regarding navigating the commands interface (thermal module display) see the paragraph "Electronic control".

5.1.1 Menu structure

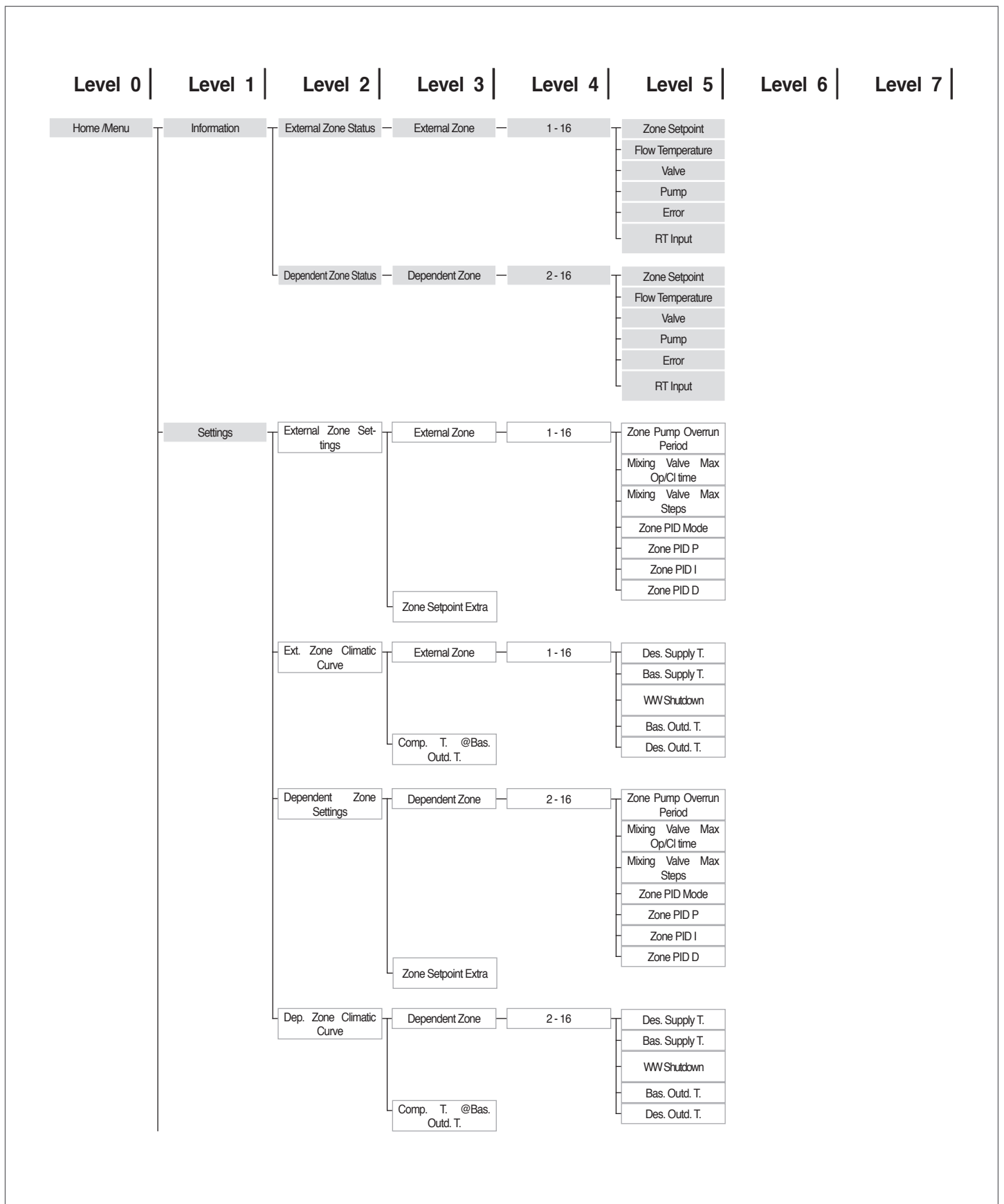

Level 0 | Level 1 | Level 2 | Level 3 | Level 4 | Level 5 | Level 6 | Level 7 |

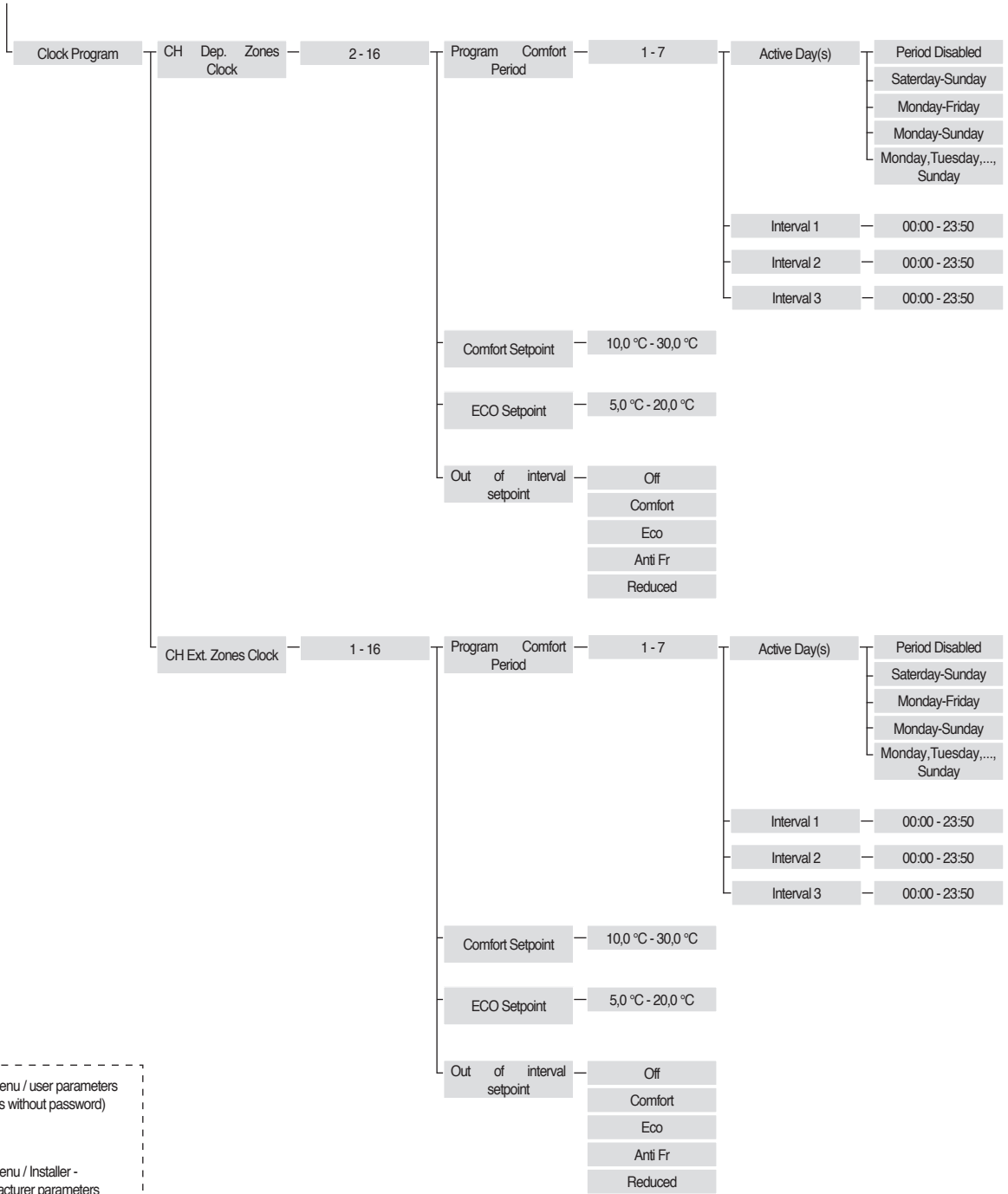

Sub-menu / user parameters
(access without password)

 Sub-menu / Installer -
Manufacturer parameters
(access with password)

5.2 Setting zone's climatic curve parameters (accessible only with installer password)

Menu → "Settings" → "Zone Clim. Curve"

- press the ► key so that the number is highlighted on the right of the word "Zone";
- use the ▲ and ▼ keys to change the zone number;
- press the ● key.

The following is displayed:

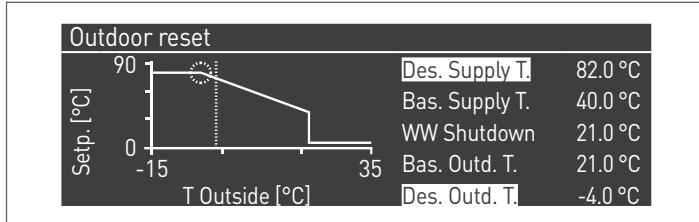

The "Comp. T. @ T.ext. Max" parameter, if other than 0, transforms the climatic curve from linear to quadratic allowing you to best adapt the variation of the setpoint to the variation of the outdoor temperature.

The resulting quadratic climatic curve will have three parameters:

- Heat. Set. Max
- Baseline Outdoor Temp.
- Text. Min

of the basic linear climatic curve and a value of the Heat. Set. Min. diminished by the value of the parameter "Comp. T. @ T.ext. Max", as can be seen in the example in the figure.

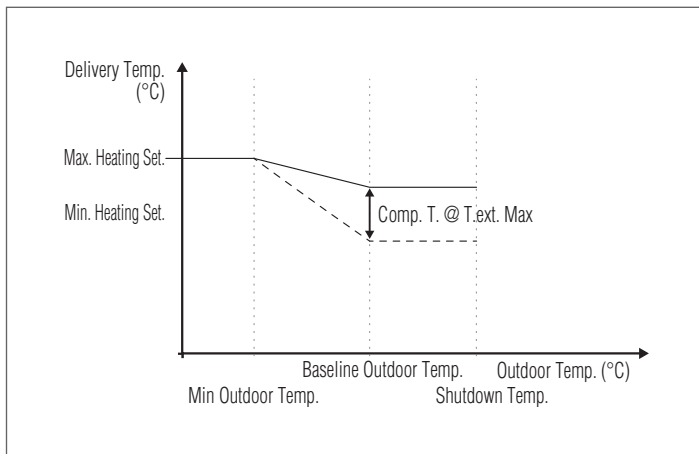

5.3 Programming the zone

By default the schedule timer is disabled.

In fact, to start a request from the zone just close the contact of the zone request. In this case the thermal module (or the cascade of thermal modules) will start with a setpoint equal to the value calculated on the zone climatic curve increased by the "Zone Extra Setpoint" value and the mix valve will modulate to maintain the delivery temperature of the zone at the calculated setpoint.

To activate zone programming:

Menu → "Settings" → "Clock Settings"

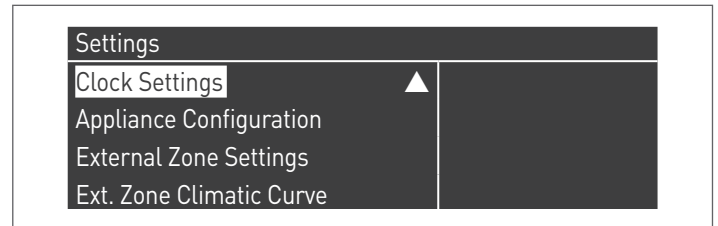

Confirming with ● the following screen is displayed:

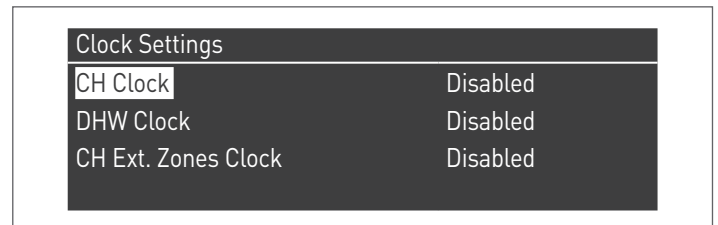

- with the ▲ / ▼ keys select "CH Zones clock"
- with the ► key move to "Disabled", change it to "Enabled" with the ▲ / ▼ keys
- confirm with the ● key

Go to:

Menu → "Clock program"

Confirming with the ● key:

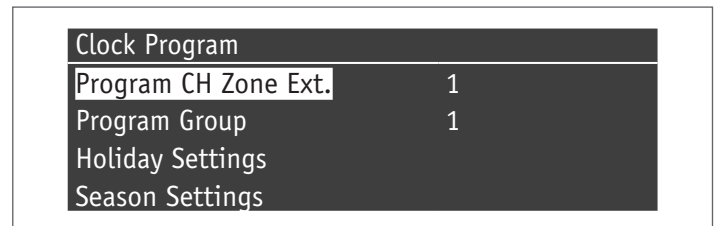

At this point select the number of the zone to be programmed and confirm with the ● key.

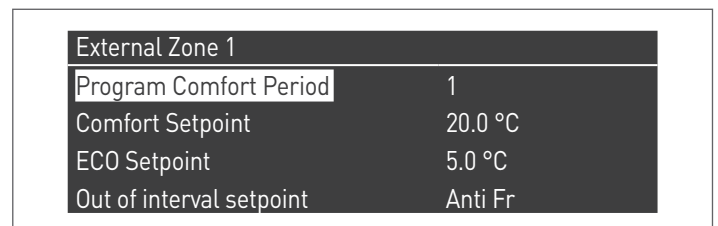

The programmable periods for each zone are 7 and they can be selected by changing the number that appears beside "Program Comfort period".

The "Comfort Setpoint" is the setpoint that is set for the area served by the zone in the active time band established within the period and can be set between ten and forty degrees. Setting the "Comfort Setpoint" at a default of 20°C, the climatic curve that regulates the setpoint of the zone is exactly that which was set in paragraph Setting zone's climatic curve parameters (accessible only with installer password) on page 20.

By changing the "Comfort Setpoint" the climatic curve is moved upwards or downwards depending on whether the setpoint is higher or lower than 20°C. The curve will shift by two degrees for each degree of difference between the value of the setpoint and the value 20.

The "ECO Setpoint" is a setpoint that can be set between 5 and 20 degrees and can be selected as a setpoint for the area served by the zone outside the active time band.

The "Out of the interval Setpoint" defines how the zone outside the active time bands are managed (within which the setpoint of the area is always set on "comfort").

The selections for the "Out of the interval Setpoint" are the following:

- **Eco:** the ambient setpoint is set to ECO. The zone setpoint is changed by two degrees less for each degree of difference between the ECO setpoint and the value 20 (for example, if at 20° I have a setpoint of 50, at 18 degrees I have a setpoint of $50+2*(18-20)=46$).
- **Night-time:** the zone setpoint is lowered by 10 degrees with respect to the value of the zone setpoint set for a $T_{comfort} = 20^\circ$.
- **Antifreeze:** the ambient setpoint is set at 5°C, thereby obtaining a reduction with respect to the comfort setpoint of 30 degrees.
- **Off:** in this case the delivery of heat is interrupted.
- **Comfort:** the setpoint remains the same as that for the active time bands. This choice clearly makes no sense when scheduling is desired, but it can be useful if you want to provide heat continuously without changing the programming itself.

 So that the zone programming works the "heat request" contact should be closed. Otherwise the zone will ignore any request from the schedule timer.

5.4 Scheduling the time bands

By going to:
Menu → "Clock program" → "Zones CH Program "

External Zone 1	
Program Comfort Period	1
Comfort Setpoint	20.0 °C
ECO Setpoint	5.0 °C
Out of interval setpoint	Anti Fr

Entering in "Program Comfort Period":

External Zone 1 - Period 1		
Active Day(s)	Monday-Sunday	
Interval 1	07:10	11:00
Interval 2	00:00	00:00
Interval 3	00:00	00:00

Using the option "Active Day(s)" it is possible to select the scheduling period. You can select a day of the week or else one of these three groups of days:

- Mon-Sun
- Mon-Fri
- Sat-Sun

This facilitates weekly scheduling or else scheduling that is different during the work week and the week-end.

There are three active time bands for each period. The time resolution is 10 minutes.

5.5 Information on the operation of the zone

By going to:
Menu → "Information" → "Zone Status"

External Zone Status 1	
External Zone	1

To choose the zone whose information will be displayed, proceed in the same way as in the previous paragraph.

Once the ● key is selected the following display appears:

External Zone 1	
Error	▲ 255
RT Input	No
Zone Setpoint	-10.0 °C
Flow Temperature	25.5 °C

External Zone 1	
Zone Setpoint	▲ -10.0 °C
Flow Temperature	25.5 °C
Valve	0%
Pump	Off

The information displayed is the following:

Error code	Description
Err	Indicates the error code of the board (255 = no error)
Input Heat	Indicates whether there is a request (namely, if the contact for the heat request is open (NO, no request) or closed (Yes, request present))
Zone set-point	Indicates the zone setpoint
Delivery temperature	Indicates the temperature measured by the zone probe
Valve	Indicates the opening percentage of the valve (100% = fully open)
Pump	Indicates if the pump is stopped (off) or active (on)

Zone board errors table:

Error code	Description	Solution
22	Zone probe disconnected	Check probe
23	Zone probe short-circuit	Check probe
24	Overtemperature detected (opening of safety thermostat)	Check parameters Check operation of mixer

5.5.1 Zone control with Depending module

If used on a cascade system, with heating zone control using DEPENDING thermal module, after carrying out the connections as described in the Cascade Manual, the following modifications need to be made.

On the display of the Depending thermal module to which the zone is connected:

Par. 9097

- if configured with value = 1 (use with circulator) it must be changed to value = 9
- if configured with value = 2 (use with 2-way valve) it must be changed to value = 8

⚠ The 9097=8 configuration CANNOT be applied to models with a boiler circulator installed as standard.

Par. 2205

By default the parameter is disabled. To enable the recognition of the zone the value must be changed from "DIS" to "ENA" and confirmed.

When the modifications are complete the following new functions will be available on the display of the device:

- in the "Information" menu the number of the connected zone appears (zone of the dependent), from where it is possible to display information about it;
- in the "Settings" menu two new lines will be displayed:
 - "Config. Zone Dep."
 - "Clim. Curve Zone Dep."
- The following new row will appear in the "Clock program" menu:
 - "Program CH Zone Dep."

5.5.2 Deleting dependent zone

To remove a Dependent zone operate in the reverse way to its installation:

- enter the parameters menu and select the par. 2205. Change its value from "ENA" to "DIS";
- change par. 9097. If par. 9097 = 9, change it to = 1; if par. 9097 = 8, change it to = 2; if par. 9097 = 49, change it to = 46.

On the "Information" menu:

- enter "Status zone dep.";
- select the number of the depending zone;
- The "Detection" field will indicate "NO";
- select "Remove zone" changing to "YES" and confirm.

Now in the "Settings" and "Information" menus the depending zone will no longer be displayed.

Cascade connection

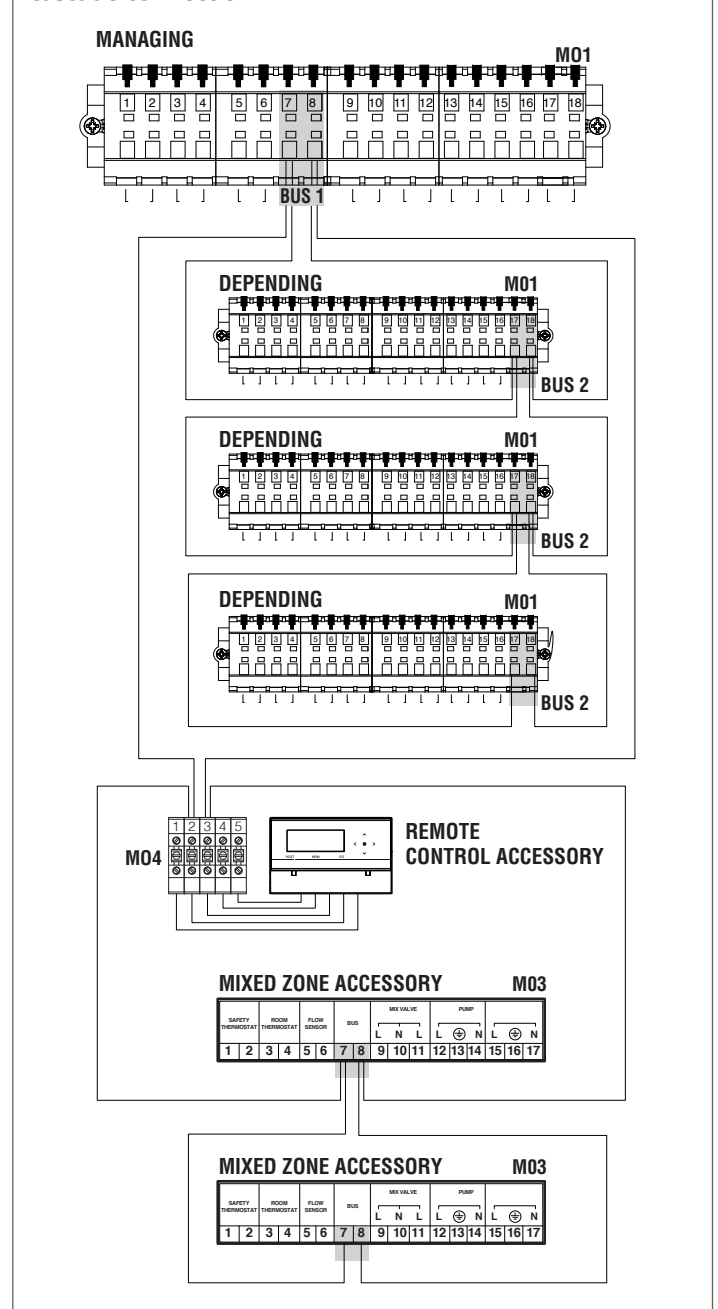

5.6 Controlling zone with additional zone accessory

When using on a system with just one thermal module or cascade systems, where the number of heating zones to be controlled exceeds the number of DEPENDING thermal modules, the additional Zone accessory module must be installed. After connecting the Zone module as indicated below, wait for the module to be detected.

At the end of the detection, the following new functions will be available:

- in the "Information" menu "Ext. Zone Status." will be displayed, from where it is possible to display information regarding the selected zone;
- in the "Settings" menu two new lines will be displayed:
 - "Zone Config."
 - "Zone Clim. Curve"

 See the additional Zone accessory booklet for further details.

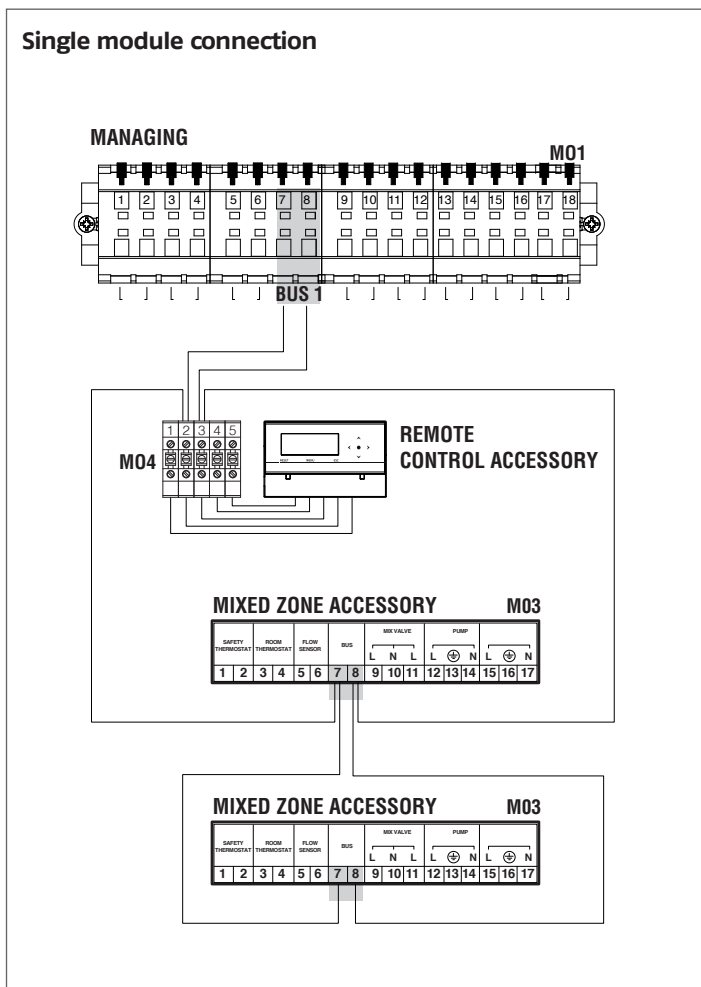

The electronic control of the thermal module will automatically check which zones are connected to the bus.

The menu items of the zone in the electronic control of the thermal module will be available when one or more zone management devices are detected.

The electronic control of the thermal module remembers the zone number detected when a device is connected.

The zone number detected is not automatically removed when the corresponding accessory is no longer connected.

The zone number needs to be removed manually.

Removing the zone number

- remove the bus connection of the zone to be deleted;
- access the Settings/Zone Config./Zone;
- select the disconnected zone;
- go to Remove Zone;
- press the ► key to highlight the values, change them to "Yes" with the ▲ / ▼ keys, press the ● key to confirm and remove the zone from the display menus.

Example:

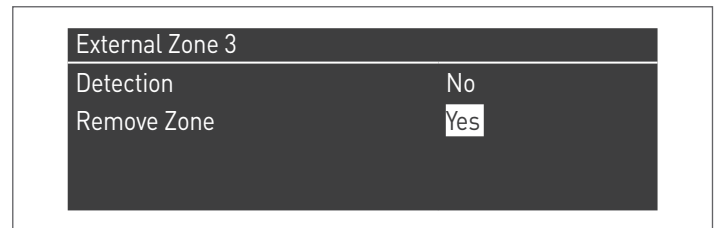
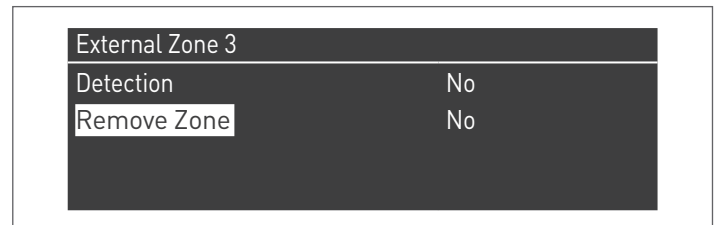

5.7 Error List

When a display has a technical fault, a numeric error code appears that will enable the maintenance operator to identify the possible cause.

There are 3 categories of errors:

- 1 Permanent: errors that require a manual reset
- 2 Temporary: errors that are automatically reset once the cause that generated them is removed or stopped
- 3 Notices: simple warnings that do not block the appliance's operation

5.7.1 Permanent Errors

Nr.	Error	Description	Checks	Solutions
0	E2PROM_READ_ERROR	Internal software error		Control board replacement
1	IGNIT_ERROR	Three unsuccessful ignition attempts in a row	Check gas supply pressure Check ignition spark Correct amount of air Check for voltage at the gas valve	If the gas supply pressure is incorrect, it must be adjusted to the correct pressure If spark is not present check for correct ignition electrode position If the combustion air pressure is incorrect, inspect the vent system and eliminate any obstructions If the voltage at the gas valve is not the same as the boiler power supply, replace the control board
2	GV_RELAY_ERROR	Failure detected in the GV (Gas Valve) relay	Check the integrity of the wire connections between gas valve and control board	If wires are damaged, replace them If the wiring is intact, replace the gas valve or the control board
3	SAFETY_RELAY_ERROR	Internal control board error		a) If the error appears during operation, replace the control board b) If the error appears when the boiler is starting up (using main switch), check that the limit thermostat (and wiring) is integral
4	BLOCKING_TOO_LONG	Control had a blocking error for more than 20 hours	Press RESET button to display the Blocking error description	Remove the cause of the Blocking error
5	FAN_ERROR_NOT_RUNNING	Fan is not running for more than 60 seconds	Check that the fan is connected to the power supply Check PWM connection of the fan	If there is no voltage, replace the control board If no PWM signal is present, replace control board Replace the fan
6	FAN_ERROR_TOO_SLOW	Fan runs too slow for more than 60 seconds		
7	FAN_ERROR_TOO_FAST	Fan runs too fast for more than 60 seconds		
8	RAM_ERROR	Internal software error		Control board replacement

Nr.	Error	Description	Checks	Solutions
9	WRONG_EEPROM_SIGNATURE	Contents of Eeprom is not up to date		Control board replacement
10	E2PROM_ERROR	Wrong safety parameters in Eeprom		Control board replacement
11	STATE_ERROR	Internal software error		Control board replacement
12	ROM_ERROR	Internal software error		Control board replacement
15	MAX_TEMP_ERROR	The external overheat protection is enabled or the T_Supply sensor measures a temperature of over 100°C (212°F)	Check the pump to verify the flow circulation Check if the valves on hydraulic circuit are open Check the safety thermostat	Change the pump or restart it Open the valves on hydraulic circuit Replace the safety thermostat
16	FLUE_GAS_ERROR	Flue temperature exceeded the maximum flue temperature		
17	STACK_ERROR	Internal software error		Control board replacement
18	INSTRUCTION_ERROR	Internal software error		Control board replacement
19	ION_CHECK_FAILED	Internal software error		Control board replacement
20	FLAME_OUT_TOO_LATE	Flame still present 10 seconds after closing the gas valve		Replace the gas valve
21	FLAME_BEFORE_IGNIT	Flame is detected before ignition		Replace the gas valve
22	Loss of flame	Flame lost three times during a request		
23	CORRUPTED_ERROR_NR	Error code RAM byte was corrupted to an unknown error code		
29	PSM_ERROR	Internal software error		
30	REGISTER_ERROR	Internal software error		Control board replacement

5.7.2 Temporary Errors

Nr.	Error	Description	Checks	Solutions
100	WD_ERROR_RAM	Internal software error		Control board replacement
101	WD_ERROR_ROM	Internal software error		Control board replacement
102	WD_ERROR_STACK	Internal software error		Control board replacement
103	WD_ERROR_REGISTER	Internal software error		Control board replacement
106	REFHI_TOO_HIGH / REFHI_TOO_LOW	Internal software error		Control board replacement
107	REFHI_TOO_HIGH / REFHI_TOO_LOW	Internal software error		Control board replacement
108	REFHI_TOO_HIGH / REFHI_TOO_LOW	Internal software error		Control board replacement
109	REFHI_TOO_HIGH / REFHI_TOO_LOW	Internal software error		Control board replacement
110	REFHI_TOO_HIGH / REFHI_TOO_LOW	Internal software error		Control board replacement
111	REFHI_TOO_HIGH / REFHI_TOO_LOW	Internal software error		Control board replacement
112	REFHI_TOO_HIGH / REFHI_TOO_LOW	Internal software error		Control board replacement
113	REFHI_TOO_HIGH / REFHI_TOO_LOW	Internal software error		Control board replacement

Nr.	Error	Description	Checks	Solutions
114	FALSE_FLAME	Flame is detected in a state in which no flame is allowed to be seen.		Control board replacement
115	LOW_WATER_PRESSURE_ERROR	Low water pressure error		
118	WD_COMM_ERROR	Watchdog communication error		Control board replacement
119	RETURN_OPEN	Return sensor open	Check the integrity of the wire connections Check the return temperature sensor	If the wiring is damaged, replace it Verify that the temperature sensor has the correct resistance values. If values are incorrect sensor must be replaced.
120	SUPPLY_OPEN	Supply sensor open	Check the integrity of the wire connections Check the return temperature sensor	If the wiring is damaged, replace it Verify that the temperature sensor has the correct resistance values. If values are incorrect sensor must be replaced.
122	DHW_OPEN	DHW sensor open	Check the integrity of the wire connections Check the DHW temperature sensor	If the wiring is damaged, replace it Verify that the temperature sensor has the correct resistance values. If values are incorrect sensor must be replaced.
123	FLUE_OPEN	Flue sensor open		
126	RETURN_SHORTED	Return sensor shorted	Check the integrity of the wire connections Check the return temperature sensor	If the wiring is damaged, replace it Verify that the temperature sensor has the correct resistance values. If values are incorrect sensor must be replaced.
127	SUPPLY_SHORTED	Supply sensor shorted	Check the integrity of the wire connections Check the return temperature sensor	If the wiring is damaged, replace it Verify that the temperature sensor has the correct resistance values. If values are incorrect sensor must be replaced.
129	DHW_SHORTED	DHW sensor shorted	Check the integrity of the wire connections Check the DHW temperature sensor	If the wiring is damaged, replace it Verify that the temperature sensor has the correct resistance values. If values are incorrect sensor must be replaced.
130	FLUE_SHORTED	Flue sensor shorted	Check the integrity of the wire connections Check the Outdoor temperature sensor	If the wiring is damaged, replace it Verify that the temperature sensor has the correct resistance values. If values are incorrect sensor must be replaced.
133	Net Freq Error	Net. freq. error detected by the watchdog		
134	RESET_BUTTON_ERROR	Too many resets in a short time period		
163	T_SELECTION1_OPEN	Heat exchanger's flow rate too low		
164	Boiler model not detected	Boiler model not set		

5.7.3 Warnings

Nr.	Error	Description	Checks	Solutions
200	CC_LOSS_COMMUNICATION	Cascade system: the burner of the managing module has lost the signal of one of the depending thermal module burner		
201	CC_LOSS_COMMUNICATION	Cascade system: the managing module has lost the signal of one of the depending thermal module		
202	OUTDOOR_WRONG	Outdoor sensor is open or shorted		
203	T_SYSTEM_WRONG	T_System sensor is open or shorted		
204	T_CASCADE_WRONG	T_Cascade sensor is open or shorted		
207	DHW sensor error	DHW sensor error		
208	Zone sensor error	Zone sensor error		
209	Boiler request disabled	Boiler request disabled		

6 RECYCLING AND DISPOSAL

The appliance is manufactured using various materials, such as metal, plastics, and electric and electronic components. At the end of the life cycle, safely remove the components and dispose of them in a responsible manner, in compliance with the installation country's applicable environmental legislation.

 Adequate sorted waste collection, processing and environmentally-friendly disposal contribute to preventing possible negative impacts on the environment and health and promote the reuse and/or recycling of the materials of which the appliance consists.

 Illegal disposal of the product by the owner shall be subject to administrative fines provided for by applicable laws.



RIELLO

RIELLO S.p.A.
Via Ing. Pilade Riello, 7
37045 - Legnago (VR)
www.riello.com



Scan the QR code to get instructions in other languages.

The manufacturer strives to continuously improve all products. Appearance, dimensions, technical specifications, standard equipment and accessories are therefore liable to modification without notice.