

MAX monobloc wall-hung hybrid systems BOX monobloc floor-standing hybrid systems



Table of contents

MAX monobloc wall-hung hybrid system	4
BOX monobloc floor-standing hybrid system	5
Heat pumps	6
Boilers	22
System diagrams	42

Monobloc wall-hung MAX hybrid system

POWER EVO-X in combination with HYDRO UNIT M SERIES



POWER MAX in combination with HYDRO UNIT M SERIES



Monobloc floor-standing BOX hybrid system

POWER MAX BOX in combination with HYDRO UNIT M 018T-030T



Heat pumps

HYDRO UNIT M 010÷016

Product Description

HYDRO UNIT M is an energy-efficient residential hydronic heat pump for heating, cooling and eventual domestic hot water production. The unit operates with environmentally friendly R32 refrigerant ensuring not only low global warming potential (GWP) and CO₂ emissions, but also high energy efficiency throughout the working range.

HYDRO UNIT M also features new exchange coils with the special Blue-Fin hydrophilic and anticorrosive treatment, which improves condensate drainage on the fins, thus reducing the risk of freezing on the coil (maximum efficiency even in humid climates).

HYDRO UNIT M is available in 7 different models with heating capacities from 10 to 15,9 kW.

- Twin-Rotary compressor with DC inverter technology, which modulates the required power to perfectly match the actual load needed.
- High COP and EER (all HYDRO UNIT M heat pumps meet the highest standards required for energy efficiency).
- Performance certified by HP Keymark.
- They can be connected to low-temperature radiators, radiant floor elements and fan coil type units.
- Water heating temperature up to +65°C.
- Quick and easy installation.
- Low-noise unit.
- Wired control included, it can fully manage a heating/cooling/domestic hot water.
- The control can manage up to 6 units in cascade (1 master and 5 slaves) even with different power.
- Standard frost protection that protects the entire system and especially the hydraulic parts from potential frost damage.

Technical data

Description	Unit	HYDRO UNIT M						
		010	012	014	016	012T	014T	016T
HEATING PERFORMANCE DATA								
Heating performance (A7°C; W35°C)								
Rated capacity	kW	10,00	12,10	14,50	15,90	12,10	14,50	15,90
Electrical absorbed power	kW	2,02	2,44	3,15	3,53	2,44	3,15	3,53
COP		4,95	4,95	4,60	4,50	4,95	4,60	4,50
SCOP (Temperate Zone)		5,19	4,81	4,72	4,62	4,81	4,72	4,62
Seasonal energy efficiency	%	205	189	186	182	189	186	182
Energy class		A+++	A+++	A+++	A+++	A+++	A+++	A+++
Heating performance (A7°C; W45°C)								
Rated capacity	kW	10,00	12,30	14,10	16,00	12,30	14,10	16,00
Input power	kW	2,67	3,32	3,92	4,57	3,32	3,92	4,57
COP		3,75	3,70	3,60	3,50	3,70	3,60	3,50
Heating performance (A7°C; W55°C)								
Rated capacity	kW	9,50	11,90	13,80	16,00	11,90	13,80	16,00
Input power	kW	3,06	3,90	4,68	5,61	3,90	4,68	5,61
COP		3,10	3,05	2,95	2,85	3,05	2,95	2,85
SCOP (Temperate Zone)		3,49	3,45	3,47	3,41	3,45	3,47	3,41
Seasonal energy efficiency	%	137	135	136	133	136	136	134
Energy class		A++	A++	A++	A++	A++	A++	A++

Description	Unit	HYDRO UNIT M						
		010	012	014	016	012T	014T	016T
PERFORMANCE DATA IN COOLING								
Cooling performance (A35°C; W7°C)								
Rated capacity	kW	8,20	11,50	12,40	14,00	11,50	12,40	14,00
Electrical absorbed power	kW	2,52	4,18	4,96	5,60	4,18	4,96	5,60
EER		3,25	2,75	2,50	2,50	2,75	2,50	2,50
SEER		5,99	4,89	4,86	4,69	4,86	4,83	4,67
Seasonal energy efficiency	%	236	193	191	185	191	190	184
Cooling performance (A35°C; W18°C)								
Rated capacity	kW	9,90	12,00	13,50	14,20	12,00	13,50	14,20
Input power	kW	2,18	3,04	3,75	4,38	3,04	3,75	4,38
EER		4,55	3,95	3,61	3,61	3,95	3,61	3,61
ELECTRICAL CHARACTERISTICS								
Electrical power supply	V/ph/Hz	230/1/50	230/1/50	230/1/50	230/1/50	400/3/50	400/3/50	400/3/50
Total maximum power consumption (1)	kW	3,70	5,50	5,80	6,20	5,50	5,80	6,20
Total maximum absorbed current (2)	A	17,00	25,00	26,00	27,00	10,00	11,00	12,00
COMPRESSOR								
Compressor	Type/Brand	Twin Rotary/ Mitsubishi	Twin Rotary/ Mitsubishi	Twin Rotary/ Mitsubishi	Twin Rotary/ Mitsubishi	Twin Rotary/ Mitsubishi	Twin Rotary/ Mitsubishi	Twin Rotary/ Mitsubishi
Adjusting	TYPE	Modulating inverter	Modulating inverter	Modulating inverter	Modulating inverter	Modulating inverter	Modulating inverter	Modulating inverter
Minimum partialization	%	38	46	41	40	46	41	40
Refrigerant	TYPE	R32	R32	R32	R32	R32	R32	R32
GWP	CO ₂ equiv. In t/kg	675	675	675	675	675	675	675
Refrigerant charge	kg	1,40	1,75	1,75	1,75	1,75	1,75	1,75
Charging the equipment	CO ₂ equiv. In t	0,95	1,18	1,18	1,18	1,18	1,18	1,18
Number of circuits	no.	1	1	1	1	1	1	1
Hermetically sealed equipment (EU Reg 517_2014)	yes/no	yes	yes	yes	yes	yes	yes	yes
FAN								
Fan	TYPE	DC axial	DC axial	DC axial	DC axial	DC axial	DC axial	DC axial
Quantity	no.	1	1	1	1	1	1	1
Maximum air flow rate	m ³ /h	4030	4060	4060	4650	4060	4060	4650
SOURCE SIDE EXCHANGER								
Source side exchanger	Type	Copper pipes, hydrophilic aluminum fins with treatment anti-corrosion	Copper pipes, hydrophilic aluminum fins with treatment anti-corrosion	Copper pipes, hydrophilic aluminum fins with treatment anti-corrosion	Copper pipes, hydrophilic aluminum fins with treatment anti-corrosion	Copper pipes, hydrophilic aluminum fins with treatment anti-corrosion	Copper pipes, hydrophilic aluminum fins with treatment anti-corrosion	Copper pipes, hydrophilic aluminum fins with treatment anti-corrosion
CIRCULATION PUMP								
Circulation pump	TYPE	Centrifuge at speed variable Para model 25/9 IPWM-130-1	Centrifuge at speed variable Para model 25/9 IPWM-130-1	Centrifuge at speed variable Para model 25/9 IPWM-130-1	Centrifuge at speed variable Para model 25/9 IPWM-130-1	Centrifuge at speed variable Para model 25/9 IPWM-130-1	Centrifuge at speed variable Para model 25/9 IPWM-130-1	Centrifuge at speed variable Para model 25/9 IPWM-130-1
Rated flow rate	m ³ /h	1,72	2,08	2,49	2,73	2,08	2,49	2,73
Maximum operating pressure	bar	3	3	3	3	3	3	3
Maximum power consumption	kW	0,043	0,043	0,043	0,043	0,043	0,043	0,043
Maximum absorbed current	A	0,44	0,44	0,44	0,44	0,44	0,44	0,44
Expansion vessel	l	8,00	8,00	8,00	8,00	8,00	8,00	8,00
SYSTEM SIDE EXCHANGER								

MAX - BOX monobloc hybrid systems

Description	Unit	HYDRO UNIT M						
		010	012	014	016	012T	014T	016T
SYSTEM SIDE EXCHANGER	TYPE	Plate in stainless	Plate in stainless	Plate in stainless	Plate in stainless	Plate in stainless	Plate in stainless	Plate in stainless
Water content	l	2,44	2,78	2,78	2,78	2,78	2,78	2,78
SOUND DATA								
Sound Power (3)	dB(A)	60	65	65	68	65	65	68
Sound pressure at 1 m (4)	dB(A)	50,5	53	53,5	57,5	53,5	54	58
WEIGHT								
Net weight	kg	105	129	129	129	144	144	144

Performance is in accordance with EN 14511 and EN 14825 standards. HP Keymark certified performance data.

(1) Power absorbed by compressors and fans and circulator at limit operating conditions with rated supply voltage.

(2) Maximum operating current of the unit with rated supply voltage.

(3) Declared noise emission values, in accordance with EN 12102-1.

(4) Measured in a semi-anechoic chamber at a distance of 1 m in front of the unit and at a height above the floor equal to $(1+H)/2$ where H is the height of the unit expressed in m, in accordance with EN 12102-1.

ERP regulation technical data table

Description	UM	HYDRO UNIT M 10	HYDRO UNIT M 12	HYDRO UNIT M 14	HYDRO UNIT M 16	HYDRO UNIT M 12T	HYDRO UNIT M 14T	HYDRO UNIT M 16T
Temperate zone - Low temperature (30/35°C) EU reg. 811_2013								
Seasonal energy efficiency	%	205	189	186	182	189	186	182
SCOP		5,19	4,81	4,72	4,62	4,81	4,72	4,62
Prated	kW	9,17	12,00	13,73	15,21	12,00	13,73	15,21
Energy class		A+++	A+++	A+++	A+++	A+++	A+++	A+++
Sound output	dB(A)	60	65	65	68	65	65	68
Temperate zone - Medium temperature (47/55°C) Reg. UE 811_2013								
Seasonal energy efficiency	%	137	135	136	133	135	136	134
SCOP		3,49	3,45	3,47	3,41	3,45	3,47	3,41
Prated	kW	7,67	11,58	12,08	13,02	11,58	12,08	13,02
Energy class		A++	A++	A++	A++	A++	A++	A++

NOTE: The performance values comply with Standards: EN 14511 - EN 14825.

Performance values in accordance with standards EN 14511:2018 and EN 14825:2016

HYDRO UNIT M 10 - HEATING

Delivery temperature	Performance with full load					
	35°C		45°C		55°C	
Outdoor temperature	Nominal capacity (kW)	COP	Nominal capacity (kW)	COP	Nominal capacity (kW)	COP
-7	8,00	3,05	7,35	2,55	6,85	2,00
2	8,20	4,00	7,85	3,20	8,10	2,56
7	10,00	4,95	10,00	3,75	9,50	3,10
12	9,03	5,77	9,11	4,06	8,50	3,41
15	9,13	6,22	9,22	4,38	8,60	3,67
20	9,58	7,14	9,46	5,08	8,73	4,05
35	8,59	9,01	9,81	6,84	8,63	5,29
Performance with partial load						
Tbival (-7°C)	A	B	C	D	-	-
Outdoor temperature (°C)	-7	2	7	12	-	-
PLR - Climate load factor	0,88	0,54	0,35	0,15	-	-
DC - Output with full load	8,00	8,20	10,00	9,03	-	-
COP with full load	3,05	4,00	4,95	5,77	-	-
COP with partial load	3,16	4,32	5,19	4,55	-	-
CR - Load factor	1,00	0,60	0,32	0,15	-	-
f COP - Corrective factor	1,00	1,08	1,05	0,79	-	-

NOTE: the performance values with a partial load refer to an output water temperature of 35°C.

HYDRO UNIT M 10 - COOLING

	Load factor	Outdoor temperature (°C)	EER	cooling output (kW)
EER1	100%	35	3,21	8,20
EER2	75%	30	4,47	6,15
EER3	50%	25	7,02	4,10
EER4	25%	20	9,54	2,05

MAX - BOX monobloc hybrid systems

HYDRO UNIT M 12 - HEATING

Performance with full load						
Delivery temperature	35°C		45°C		55°C	
Outdoor temperature	Nominal capacity (kW)	COP	Nominal capacity (kW)	COP	Nominal capacity (kW)	COP
-7	10,00	3,00	10,20	2,40	9,80	2,05
2	9,20	3,90	10,60	3,00	11,30	2,50
7	12,10	4,95	12,30	3,70	11,90	3,05
12	10,98	5,75	11,10	4,26	9,53	3,17
15	11,00	5,97	11,20	4,52	9,12	3,20
20	10,80	7,18	11,20	5,16	9,00	3,61
35	11,50	8,78	11,50	6,17	10,00	4,86
Performance with partial load						
Tbival (-7°C)	A	B	C	D	-	-
Outdoor temperature (°C)	-7	2	7	12	-	-
PLR - Climate load factor	0,88	0,54	0,35	0,15	-	-
DC - Output with full load	10,00	9,20	12,10	10,98	-	-
COP with full load	3,00	3,90	4,95	5,75	-	-
COP with partial load	2,82	4,01	4,85	4,14	-	-
CR - Load factor	1,00	0,70	0,35	0,16	-	-
f COP - Corrective factor	1,00	1,03	0,98	0,72	-	-

NOTE: the performance values with a partial load refer to an output water temperature of 35°C.

HYDRO UNIT M 12 - COOLING

	Load factor	Outdoor temperature (°C)	EER	cooling output (kW)
EER1	100%	35	2,61	11,50
EER2	75%	30	3,93	8,63
EER3	50%	25	5,73	5,75
EER4	25%	20	6,75	2,88

HYDRO UNIT M 14 - HEATING

Performance with full load						
Delivery temperature	35°C		45°C		55°C	
Outdoor temperature	Nominal capacity (kW)	COP	Nominal capacity (kW)	COP	Nominal capacity (kW)	COP
-7	12,00	2,85	11,80	2,35	11,00	2,05
2	11,00	3,60	11,50	2,85	12,40	2,45
7	14,50	4,60	14,10	3,60	13,80	2,95
12	11,51	5,46	11,69	4,12	10,28	3,32
15	11,60	5,67	11,90	4,25	9,84	3,41
20	11,10	6,27	11,50	4,87	9,53	3,74
35	11,80	8,63	12,00	6,10	10,10	4,93
Performance with partial load						
Tbival (-7°C)	A	B	C	D	-	-
Outdoor temperature (°C)	-7	2	7	12	-	-
PLR - Climate load factor	0,88	0,54	0,35	0,15	-	-
DC - Output with full load	12,00	11,00	14,50	11,51	-	-
COP with full load	2,85	3,60	4,60	5,46	-	-
COP with partial load	2,73	3,90	4,90	4,26	-	-
CR - Load factor	1,00	0,67	0,33	0,18	-	-
f COP - Corrective factor	1,00	1,08	1,06	0,78	-	-

NOTE: the performance values with a partial load refer to an output water temperature of 35°C.

HYDRO UNIT M 14 - COOLING

	Load factor	Outdoor temperature (°C)	EER	cooling output (kW)
EER1	100%	35	2,50	12,40
EER2	75%	30	3,85	9,30
EER3	50%	25	5,80	6,20
EER4	25%	20	6,74	3,10

HYDRO UNIT M 16 - HEATING

Delivery temperature	Performance with full load					
	35°C		45°C		55°C	
Outdoor temperature	Nominal capacity (kW)	COP	Nominal capacity (kW)	COP	Nominal capacity (kW)	COP
-7	13,10	2,70	12,80	2,25	12,50	2,00
2	13,00	3,45	12,70	2,85	13,30	2,40
7	15,90	4,50	16,00	3,50	16,00	2,85
12	14,03	5,58	13,76	4,22	12,69	3,44
15	14,50	5,97	14,20	4,46	13,20	3,61
20	12,70	6,88	12,20	4,71	11,20	3,68
35	12,80	9,06	12,50	6,02	10,40	4,57
Performance with partial load						
Tbival (-7°C)	A	B	C	D	-	-
Outdoor temperature (°C)	-7	2	7	12	-	-
PLR - Climate load factor	0,88	0,54	0,35	0,15	-	-
DC - Output with full load	13,10	13,00	15,90	14,03	-	-
COP with full load	2,70	3,45	4,50	5,58	-	-
COP with partial load	2,66	3,80	4,81	4,32	-	-
CR - Load factor	1,00	0,63	0,33	0,16	-	-
f COP - Corrective factor	1,00	1,10	1,07	0,77	-	-

NOTE: the performance values with a partial load refer to an output water temperature of 35°C.

HYDRO UNIT M 16 - COOLING

	Load factor	Outdoor temperature (°C)	EER	cooling output (kW)
EER1	100%	35	2,47	14,00
EER2	75%	30	3,63	10,50
EER3	50%	25	5,27	7,00
EER4	25%	20	7,29	3,50

HYDRO UNIT M 12T - HEATING

Delivery temperature	Performance with full load					
	35°C		45°C		55°C	
Outdoor temperature	Nominal capacity (kW)	COP	Nominal capacity (kW)	COP	Nominal capacity (kW)	COP
-7	10,00	3,00	10,20	2,40	9,80	2,05
2	9,20	3,90	10,60	3,00	11,30	2,50
7	12,10	4,95	12,30	3,70	11,90	3,05
12	10,98	5,75	11,10	4,26	9,53	3,17
15	11,00	5,97	11,20	4,52	9,12	3,20
20	10,80	7,18	11,20	5,16	9,00	3,61
35	11,50	8,78	11,50	6,17	10,00	4,86
Performance with partial load						
Tbival (-7°C)	A	B	C	D	-	-
Outdoor temperature (°C)	-7	2	7	12	-	-
PLR - Climate load factor	0,88	0,54	0,35	0,15	-	-
DC - Output with full load	10,00	9,20	12,10	10,98	-	-
COP with full load	3,00	3,90	4,95	5,75	-	-
COP with partial load	2,82	4,01	4,85	4,14	-	-
CR - Load factor	1,00	0,70	0,35	0,16	-	-
f COP - Corrective factor	1,00	1,03	0,98	0,72	-	-

NOTE: the performance values with a partial load refer to an output water temperature of 35°C.

HYDRO UNIT M 12T - COOLING

	Load factor	Outdoor temperature (°C)	EER	cooling output (kW)
EER1	100%	35	2,61	11,50
EER2	75%	30	3,93	8,63
EER3	50%	25	5,73	5,75
EER4	25%	20	6,75	2,88

MAX - BOX monobloc hybrid systems

HYDRO UNIT M 14T - HEATING

Delivery temperature	Performance with full load					
	35°C		45°C		55°C	
Outdoor temperature	Nominal capacity (kW)	COP	Nominal capacity (kW)	COP	Nominal capacity (kW)	COP
-7	12,00	2,85	11,80	2,35	11,00	2,05
2	11,00	3,60	11,50	2,85	12,40	2,45
7	14,50	4,60	14,10	3,60	13,80	2,95
12	11,51	5,46	11,69	4,12	10,28	3,32
15	11,60	5,67	11,90	4,25	9,84	3,41
20	11,10	6,27	11,50	4,87	9,53	3,74
35	11,80	8,63	12,00	6,10	10,10	4,93
Performance with partial load						
Tbival (-7°C)	A	B	C	D	-	-
Outdoor temperature (°C)	-7	2	7	12	-	-
PLR - Climate load factor	0,88	0,54	0,35	0,15	-	-
DC - Output with full load	12,00	11,00	14,50	11,51	-	-
COP with full load	2,85	3,60	4,60	5,46	-	-
COP with partial load	2,73	3,90	4,90	4,26	-	-
CR - Load factor	1,00	0,67	0,33	0,18	-	-
f COP - Corrective factor	1,00	1,08	1,06	0,78	-	-

NOTE: the performance values with a partial load refer to an output water temperature of 35°C.

HYDRO UNIT M 14T - COOLING

	Load factor	Outdoor temperature (°C)	EER	cooling output (kW)
EER1	100%	35	2,46	12,40
EER2	75%	30	3,85	9,30
EER3	50%	25	5,80	6,20
EER4	25%	20	6,74	3,10

HYDRO UNIT M 16T - HEATING

Delivery temperature	Performance with full load					
	35°C		45°C		55°C	
Outdoor temperature	Nominal capacity (kW)	COP	Nominal capacity (kW)	COP	Nominal capacity (kW)	COP
-7	13,10	2,70	12,80	2,25	12,50	2,00
2	13,00	3,45	12,70	2,85	13,30	2,40
7	15,90	4,50	16,00	3,50	16,00	2,85
12	14,03	5,58	13,76	4,22	12,69	3,44
15	14,50	5,97	14,20	4,46	13,20	3,61
20	12,70	6,88	12,20	4,71	11,20	3,68
35	12,80	9,06	12,50	6,02	10,40	4,57
Performance with partial load						
Tbival (-7°C)	A	B	C	D	-	-
Outdoor temperature (°C)	-7	2	7	12	-	-
PLR - Climate load factor	0,88	0,54	0,35	0,15	-	-
DC - Output with full load	13,10	13,00	15,90	14,03	-	-
COP with full load	2,70	3,45	4,50	5,58	-	-
COP with partial load	2,66	3,80	4,81	4,32	-	-
CR - Load factor	1,00	0,63	0,33	0,16	-	-
f COP - Corrective factor	1,00	1,10	1,07	0,77	-	-

NOTE: the performance values with a partial load refer to an output water temperature of 35°C.

HYDRO UNIT M 16T - COOLING

	Load factor	Outdoor temperature (°C)	EER	cooling output (kW)
EER1	100%	35	2,47	14,00
EER2	75%	30	3,63	10,50
EER3	50%	25	5,27	7,00
EER4	25%	20	7,29	3,50

Operating range

Cooling mode

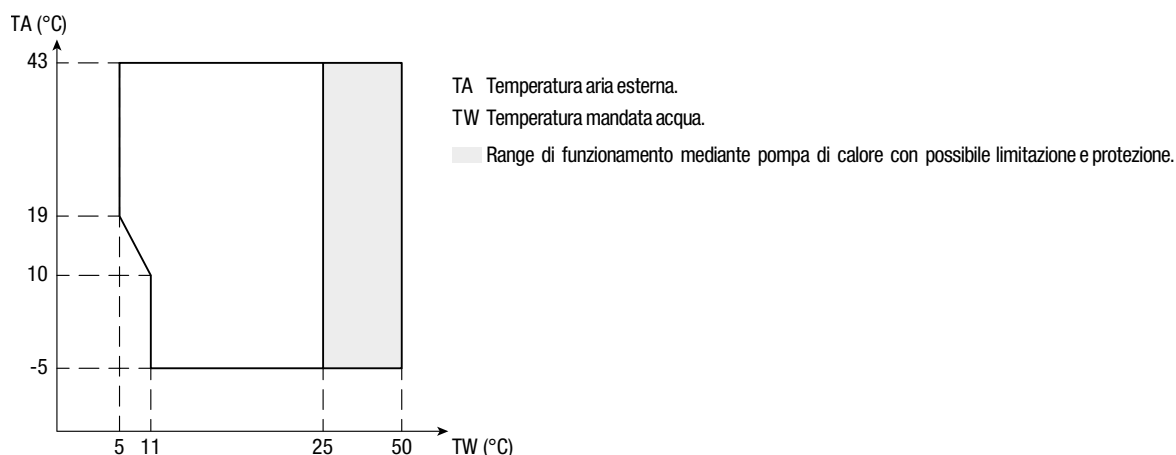

Heating mode

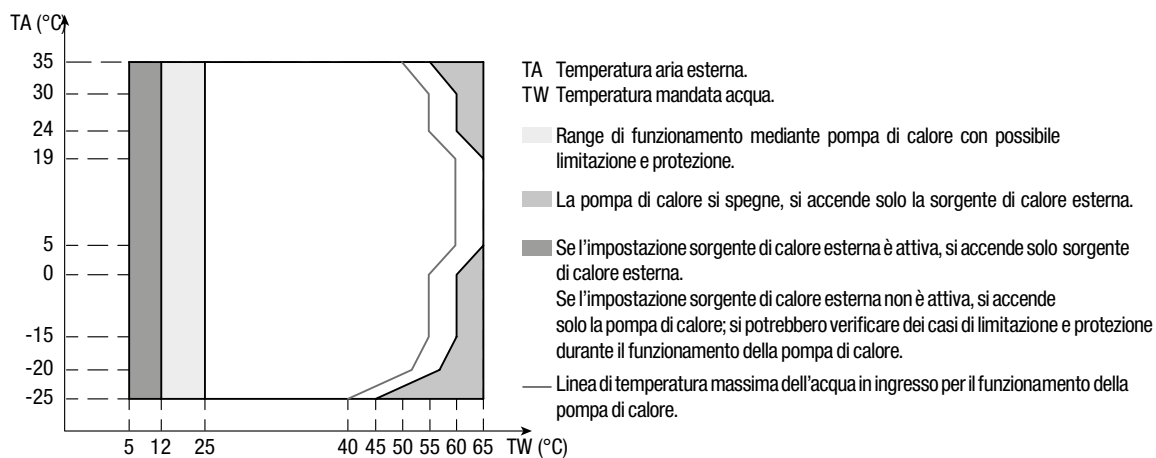

ACS mode

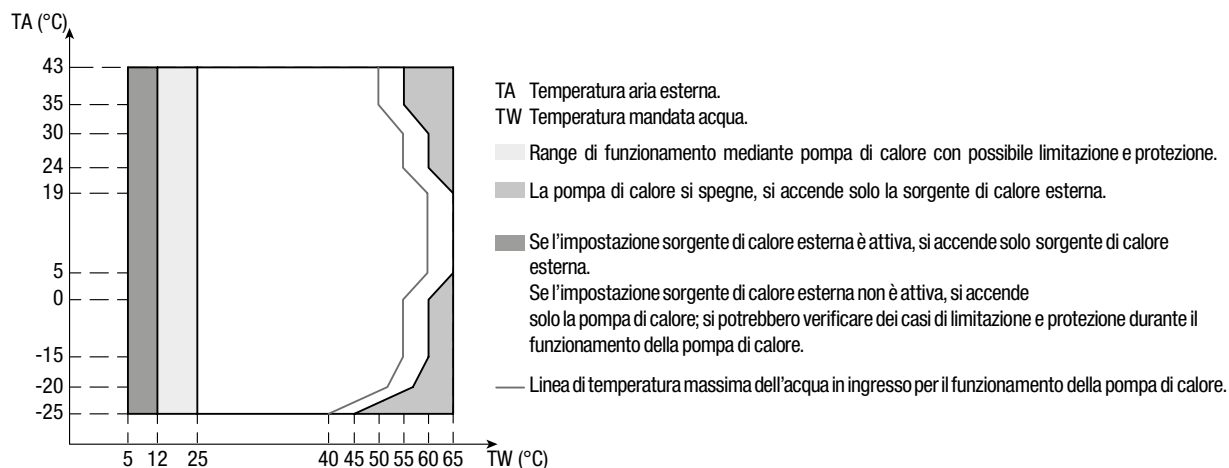

Overall dimensions

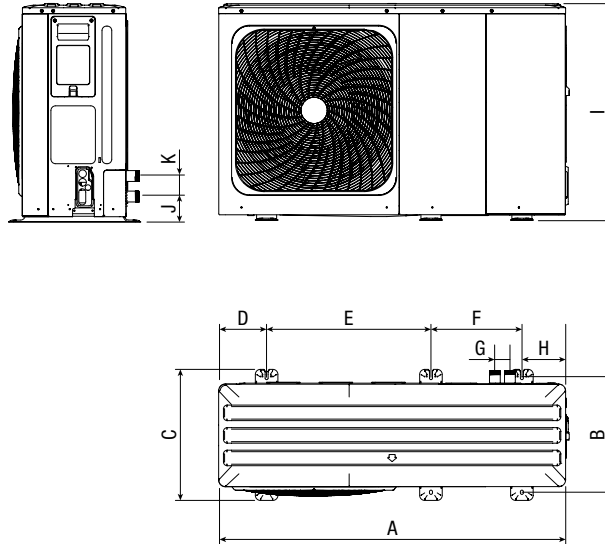

A	B	C	D	E	F	G	H	I	J	K
mm	mm	mm	mm	mm	mm	mm	mm	mm	mm	mm
1385	458	523	192	656	363	60	221	865	101	81

HYDRO UNIT M 018T÷030T



Product Description

HYDRO UNIT M 018÷030 is the ideal proposal for any type of residential and commercial heating and cooling application, with the possibility of energy-efficient domestic hot water production.

The unit operates with environmentally friendly R32 refrigerant ensuring not only low global warming potential (GWP) and CO2 emissions, but also high energy efficiency throughout the working range.

HYDRO UNIT M 018÷030 also features new exchange coils with the special hydrophilic and anticorrosive Blue-Fin treatment, which improves condensate drainage on the fins, thus reducing the risk of freezing on the coil (maximum efficiency even in humid climates).

The unit is monobloc, so all the components are built-in to make installation operations easier and quicker.

HYDRO UNIT M 018÷030 is supplied with the climate control as standard, and it is available in 4 models from 18 to 30 kW.

- Twin-Rotary compressor with DC inverter technology, which modulates the required power to perfectly match the actual load needed.
- High COP and EER (all HYDRO UNIT M heat pumps meet the highest standards required for energy efficiency).
- Performance certified by HP Keymark.
- They can be connected to low-temperature radiators, radiant floor elements and fan coil type units.
- Water heating temperature up to +60 °C.
- Quick and easy installation.
- Low-noise unit.
- Wired control included, it can fully manage a heating/cooling/domestic hot water.
- The control can manage up to 6 units in cascade (1 master and 5 slaves) even with different power.
- Standard frost protection that protects the entire system and especially the hydraulic parts from potential frost damage.

Technical data

Description	Unit	HYDRO UNIT M			
		018T	022T	026T	030T
HEATING PERFORMANCE DATA					
Heating performance (A7°C; W35°C)					
Rated capacity	kW	18,00	22,00	26,00	30,10
Input power	kW	3,83	5,00	6,37	7,70
COP		4,70	4,40	4,08	3,91
SCOP (Temperate Zone)		4,6	4,53	4,5	4,19
Seasonal energy efficiency	%	181	178	177	165
Energy class		A+++	A+++	A+++	A++
Heating performance (A7°C; W45°C)					
Rated capacity	kW	18,00	22,00	26,00	30,00
Input power	kW	5,14	6,47	8,39	10,34
COP		3,50	3,40	3,10	2,90
Heating performance (A7°C; W55°C)					
Rated capacity	kW	18,00	22,00	26,00	30,00
Electrical absorbed power	kW	6,55	8,30	10,61	13,04
COP		2,75	2,65	2,45	2,30
SCOP (Temperate Zone)		3,21	3,22	3,14	3,14
Seasonal energy efficiency	%	125	126	123	123
Energy class		A++	A++	A+	A+
PERFORMANCE DATA IN COOLING					
Cooling performance (A35°C; W7°C)					
Rated capacity	kW	17,00	21,00	26,00	29,50
Electrical absorbed power	kW	5,57	7,12	9,63	11,57
EER		3,05	2,95	2,70	2,55
SEER		4,70	4,70	4,66	4,49
Seasonal energy efficiency	%	185	185	183	177

MAX - BOX monobloc hybrid systems

Description	Unit	HYDRO UNIT M			
		018T	022T	026T	030T
Cooling performance (A35°C; W18°C)					
Rated capacity	kW	18,50	23,00	27,00	31,00
Electrical absorbed power	kW	3,89	5,00	6,28	7,75
EER		4,75	4,60	4,30	4,00
ELECTRICAL CHARACTERISTICS					
Electrical supply	V/ph/Hz	400/3/50	400/3/50	400/3/50	400/3/50
Total maximum power consumption (1)	kW	10,60	12,50	13,80	14,50
Total maximum absorbed current (2)	A	16,80	19,60	21,60	22,80
COMPRESSOR					
Compressor	Type/Brand	Twin Rotary/ Mitsubishi	Twin Rotary/ Mitsubishi	Twin Rotary/ Mitsubishi	Twin Rotary/ Mitsubishi
Adjusting	Type	Modulating inverter	Modulating inverter	Modulating inverter	Modulating inverter
Minimum partialization	%	24	24	24	24
Refrigerant	Type	R32	R32	R32	R32
GWP	CO ₂ equiv. In t/kg	675	675	675	675
Refrigerant charge	kg	5,00	5,00	5,00	5,00
Charging the equipment	CO ₂ equiv. In t	3,38	3,38	3,38	3,38
Number of circuits	no.	1	1	1	1
Hermetically sealed equipment (EU Reg 517_2014)	yes/no	yes	yes	yes	yes
FAN					
Fan	TYPE	Axial	Axial	Axial	Axial
Quantity	no.	2	2	2	2
Maximum air flow rate	m ³ /h	10650	10650	11200	11200
SOURCE SIDE EXCHANGER					
Source side exchanger	TYPE	Copper tubes with groove, hydrophilic aluminum fins with anti-corrosion treatment	Copper tubes with groove, hydrophilic aluminum fins with anti-corrosion treatment	Copper tubes with groove, hydrophilic aluminum fins with anti-corrosion treatment	Copper tubes with groove, hydrophilic aluminum fins with anti-corrosion treatment
CIRCULATION PUMP					
Circulation pump	TYPE	3-speed centrifuge	3-speed centrifuge	3-speed centrifuge	3-speed centrifuge
Rated flow rate	m ³ /h	3,10	3,79	4,48	5,19
Maximum operating pressure	bar	3	3	3	3
Maximum power consumption	kW	0,262	0,262	0,262	0,262
Maximum absorbed current	A	1,20	1,20	1,20	1,20
Expansion vessel volume	l	8,00	8,00	8,00	8,00
SYSTEM SIDE EXCHANGER					
SYSTEM SIDE EXCHANGER	Type	Plate AISI316	Plate AISI316	Plate AISI316	Plate AISI316
Water content	l	3,5	3,5	3,5	3,5
SOUND DATA					
Sound Power (3)	dB(A)	71	73	75	77
Sound pressure at 1 m (4)	dB(A)	57,6	59,8	61,5	63,5
WEIGHT					
Net weight	kg	177	177	177	177

Performance is in accordance with EN 14511 and EN 14825 standards. HP Keymark certified performance data.

(1) Power absorbed by compressors and fans and circulator at limit operating conditions with rated supply voltage.

(2) Maximum operating current of the unit with rated supply voltage.

(3) Declared noise emission values, in accordance with EN 12102-1.

(4) Measured in a semi-anechoic chamber at a distance of 1 m in front of the unit and at a height above the floor equal to (1+H)/2 where H is the height of the unit expressed in m, in accordance with EN 12102-1.

ERP regulation technical data table

Parameter	Unit	Hydro Unit M			
		018T	022T	026T	030T
Temperate zone - Low temperature (30/35°C) EU reg. 811_2013					
Seasonal energy efficiency	%	181	178	177	165
SCOP		4,60	4,53	4,50	4,19
Prated	kW	17,99	22,31	25,04	29,18
Energy class		A+++	A+++	A+++	A++
Sound output	dB(A)	71	73	75	77
Temperate zone - Medium temperature (47/55°C) EU reg. 811_2013					
Seasonal energy efficiency	%	125	126	123	123
SCOP		3,21	3,22	3,14	3,14
Prated	kW	17,67	22,43	26,15	29,69
Energy class		A++	A++	A+	A+

The performance values comply with UNI EN:14511 and UNI EN 14825 standards.

Performance in accordance with EN 14511 and EN 14825 Standards

HYDRO UNIT M 018T - HEATING

Delivery temperature	Performance with full load					
	35°C		45°C		55°C	
Outdoor temperature	Nominal capacity (kW)	COP	Nominal capacity (kW)	COP	Nominal capacity (kW)	COP
-7	19,91	2,37	16,16	1,98	10,08	1,18
2	20,23	3,16	19,97	2,64	17,74	2,15
7	18,00	4,70	18,00	3,50	18,00	2,75
12	21,22	4,17	19,34	3,60	18,57	2,90
15	22,08	4,32	20,89	3,89	19,18	3,22
20	23,78	4,46	21,28	4,08	20,38	3,44
35	12,48	6,58	11,91	5,24	11,13	3,81
Performance with partial load						
Tbival (-7°C)	A	B	C	D	-	-
Outdoor temperature (°C)	-7	2	7	12	-	-
PLR - Climate load factor	0,88	0,54	0,35	0,15	-	-
DC - Output with full load	19,91	20,23	18,00	21,22	-	-
COP with full load	2,37	3,16	4,70	4,17	-	-
COP with partial load	2,79	3,96	4,39	3,69	-	-
CR - Load factor	1,00	0,48	0,35	0,13	-	-
f COP - Corrective factor	1,00	1,25	0,93	0,88	-	-

NOTE: the performance values with a partial load refer to an output water temperature of 35°C.

HYDRO UNIT M 018T - COOLING

	Load factor	Outdoor temperature (°C)	EER
EER1	100%	35	3,05
EER2	75%	30	4,13
EER3	50%	25	5,59
EER4	25%	20	5,55

HYDRO UNIT M 022T - HEATING

Delivery temperature	Performance with full load					
	35°C		45°C		55°C	
Outdoor temperature	Nominal capacity (kW)	COP	Nominal capacity (kW)	COP	Nominal capacity (kW)	COP
-7	21,28	2,44	19,82	2,03	12,55	1,25
2	23,24	3,02	23,02	2,51	21,04	2,12
7	22,00	4,40	22,00	3,40	22,00	2,65
12	25,95	3,99	24,15	3,37	22,99	2,822
15	28,05	4,13	26,31	3,56	24,59	3,11
20	27,75	4,33	25,97	3,77	23,95	3,30
35	12,46	6,48	11,88	5,17	11,20	3,81
Performance with partial load						
Tbival (-7°C)	A	B	C	D	-	-
Outdoor temperature (°C)	-7	2	7	12	-	-
PLR - Climate load factor	0,88	0,54	0,35	0,15	-	-
DC - Output with full load	21,28	23,24	22,00	25,95	-	-
COP with full load	2,44	3,02	4,40	3,99	-	-
COP with partial load	2,68	3,80	4,61	3,81	-	-
CR - Load factor	1,00	0,52	0,35	0,13	-	-
f COP - Corrective factor	1,10	1,26	1,05	0,95	-	-

NOTE: the performance values with a partial load refer to an output water temperature of 35°C.

HYDRO UNIT M 022T - COOLING

	Load factor	Outdoor temperature (°C)	EER
EER1	100%	35	2,95
EER2	75%	30	3,95
EER3	50%	25	5,37
EER4	25%	20	6,19

HYDRO UNIT M 026T - HEATING

Performance with full load						
Delivery temperature	35°C		45°C		55°C	
Outdoor temperature	Nominal capacity (kW)	COP	Nominal capacity (kW)	COP	Nominal capacity (kW)	COP
-7	23,46	2,52	21,45	2,08	15,28	1,31
2	25,44	2,90	26,17	2,40	23,10	2,09
7	26,00	4,08	26,00	3,10	26,00	2,45
12	29,34	3,82	28,67	3,17	26,05	2,75
15	30,79	3,95	30,62	3,30	26,56	3,00
20	32,48	4,21	30,13	3,53	26,78	3,18
35	12,43	6,38	11,85	5,10	11,26	3,81
Performance with partial load						
Tbival (-7°C)	A	B	C	D	-	-
Outdoor temperature (°C)	-7	2	7	12	-	-
PLR - Climate load factor	0,88	0,54	0,35	0,15	-	-
DC - Output with full load	23,46	25,44	26,00	29,34	-	-
COP with full load	2,52	2,90	4,08	3,82	-	-
COP with partial load	2,52	3,83	4,78	3,98	-	-
CR - Load factor	1,00	0,53	0,34	0,13	-	-
f COP - Corrective factor	1,00	1,32	1,17	1,04	-	-

NOTE: the performance values with a partial load refer to an output water temperature of 35°C.

HYDRO UNIT M 026T - COOLING

	Load factor	Outdoor temperature (°C)	EER
EER1	100%	35	2,70
EER2	75%	30	3,79
EER3	50%	25	5,19
EER4	25%	20	6,84

HYDRO UNIT M 030T - HEATING

Performance with full load						
Delivery temperature	35°C		45°C		55°C	
Outdoor temperature	Nominal capacity (kW)	COP	Nominal capacity (kW)	COP	Nominal capacity (kW)	COP
-7	24,85	2,54	25,43	2,13	19,93	1,56
2	26,02	2,86	28,19	2,29	24,65	1,97
7	30,10	3,91	30,00	2,90	30,00	2,30
12	31,14	3,67	33,35	3,01	31,14	2,68
15	32,70	3,79	36,01	3,09	32,59	2,90
20	32,70	4,08	35,34	3,33	32,48	3,06
35	12,41	6,29	11,82	5,03	11,33	3,80
Performance with partial load						
Tbival (-7°C)	A	B	C	D	-	-
Outdoor temperature (°C)	-7	2	7	12	-	-
PLR - Climate load factor	0,88	0,54	0,35	0,15	-	-
DC - Output with full load	24,85	26,02	30,10	31,14	-	-
COP with full load	2,54	2,86	3,91	3,67	-	-
COP with partial load	2,49	3,59	4,68	4,18	-	-
CR - Load factor	1,00	0,61	0,34	0,14	-	-
f COP - Corrective factor	1,00	1,25	1,20	1,14	-	-

NOTE: the performance values with a partial load refer to an output water temperature of 35°C.

HYDRO UNIT M 030T - COOLING

	Load factor	Outdoor temperature (°C)	EER
EER1	100%	35	2,55
EER2	75%	30	3,62
EER3	50%	25	5,06
EER4	25%	20	6,75

Operating range

Cooling mode

MODALITÀ RAFFRESCAMENTO

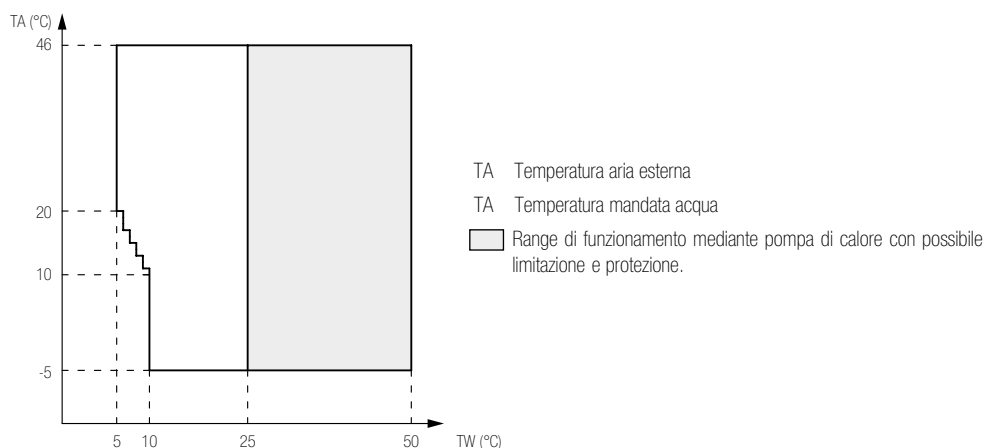

Heating mode

MODALITÀ RISCALDAMENTO

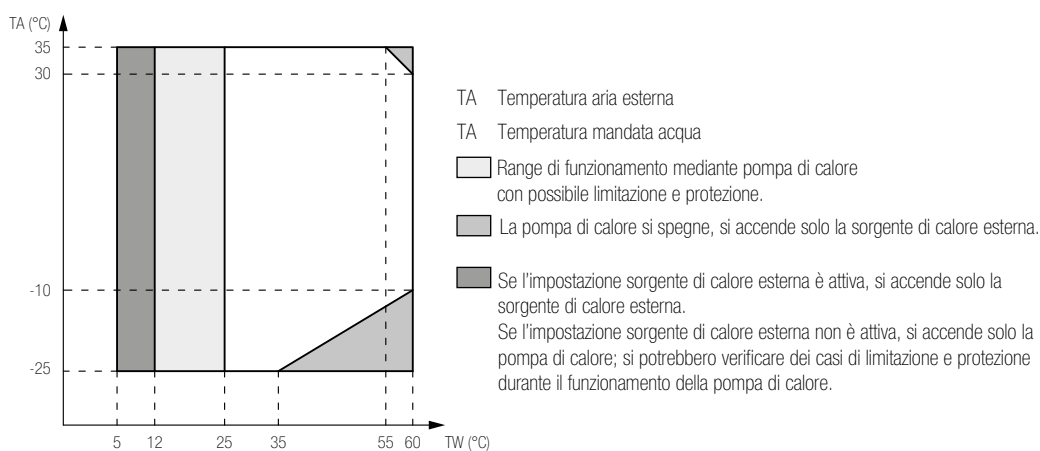

ACS mode

MODALITÀ ACS

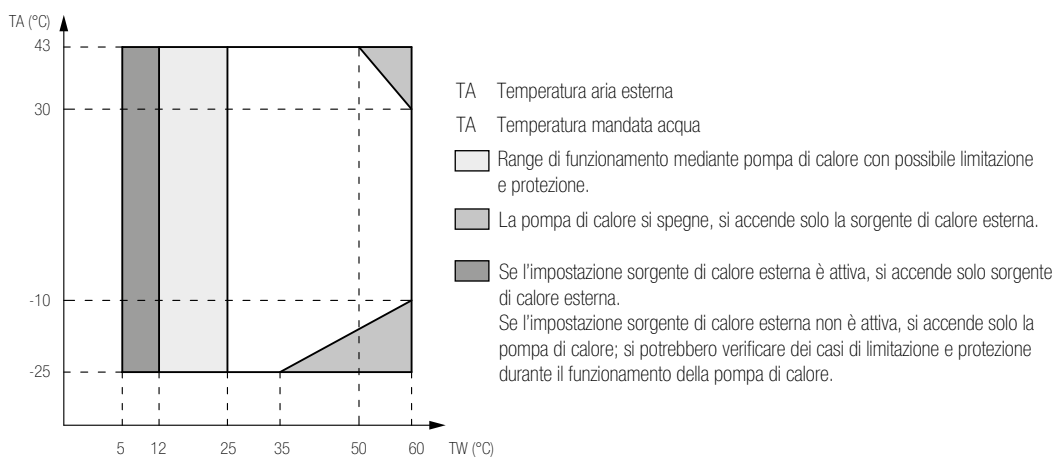

Overall dimensions

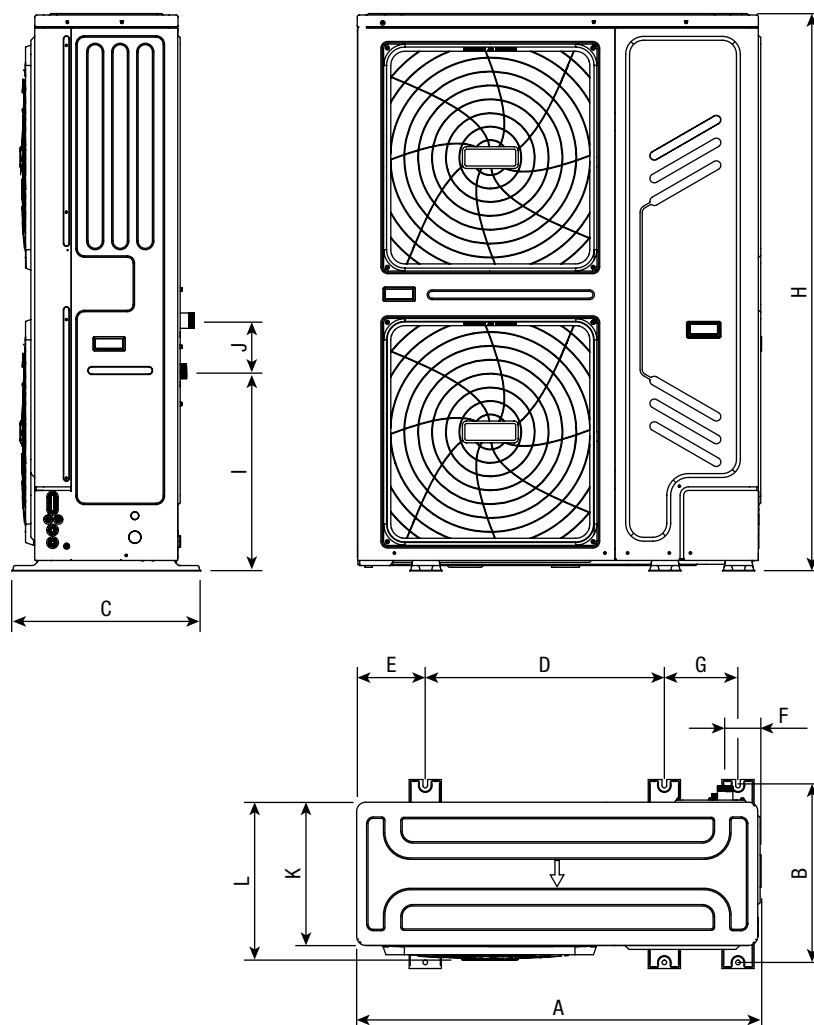

A	mm	1129
B	mm	494
C	mm	528
D	mm	668
E	mm	192
F	mm	98
G	mm	206
H	mm	1558
I	mm	558
J	mm	143
K	mm	400
L	mm	440

Boilers

POWER EVO-X (stand alone)

Product Description

POWER EVO-X is the modular wall-mounted condensing system that makes compactness its strong point. The horizontally developed stainless steel primary exchanger, with front accessibility to the combustion chamber, ensures high performance in terms of efficiency and reliability over time.

The range consists of 4 models in heating-only version, with thermal modules from 34.9 up to 70 kW.

POWER EVO-X can be installed individually indoors or in a partially protected location, while up to 4 modules can be installed internally in cascade, either in a Linear or Back-to-Back configuration.

Battery system management is done by means of the new simple and intuitive external system controller, which is also capable of managing, parameterizing and displaying up to 4 modules in cascade as well as managing up to 6 additional independent zones.

- Designed to operate with mixtures of natural gas and hydrogen, up to a maximum of 20%.
- Modulation ratio 1:8 in single installation, up to 1:32 in battery installation.
- Modulating circulator with high head and low consumption.
- Maximum operating pressure 5 bar.
- Ease of installation.
- Wide range of accessories to complete single and battery installation in both linear and back-to-back configurations.

Technical data

DESCRIPTION	U.M.	POWER EVO-X							
		50 DEP		50		65		80	
Gas type		G20	G31	G20	G31	G20	G31	G20	G31
Gas category		II 2H3P appliance		II 2H3P appliance		II 2H3P appliance		II 2H3P appliance	
Flue systems installation type		B23P; B53P; C13,C13x; C33,C33x; C43,C43x; C53,C53x; C63,C63x; C83,C83x; C93,C93x							
HEATING									
Nominal heat flow rate (Hi)	kW	34,90		45,00		55,00		70,00	
Rated heat output (80÷60°C)	kW	34,00		43,88		53,60		68,22	
Rated heat output (50÷30°C)	kW	37,31		47,30		58,25		74,19	
Reduced heat flow rate (Hi)	kW	5,20	-	5,20	-	8,20	-	8,20	-
Reduced heat output (80÷60°C)	kW	4,98	-	4,98	-	7,87	-	7,87	-
Reduced heat output (50÷30°C)	kW	5,57	-	5,57	-	8,78	-	8,78	-
DOMESTIC WATER									
Nominal heat flow rate (Hi)	kW	34,90		45,00		55,00		70,00	
Nominal heat output	(*) kW	34,90		45,00		55,00		70,00	
Reduced heat flow rate (Hi)	kW	5,20	-	5,20	-	8,20	-	8,20	-
Reduced heat output	(*) kW	5,20	-	5,20	-	8,20	-	8,20	-
Modulating ratio		1:7		1:8		1:7		1:8	
EFFICIENCY									
Useful efficiency P max (80÷60°C)	%	97,4		97,5		97,5		97,5	
Useful efficiency P min (80÷60°C)	%	95,8		95,8		96,0		96,0	
Useful efficiency Pn max (50÷30°C)	%	106,9		105,1		105,9		106,0	
Useful efficiency Pn min (50÷30°C)	%	107,2		107,2		107,0		107,0	
Useful efficiency 30 % (return 30°C)	%	108,2		107,9		107,6		107,5	
Chimney losses with burner on (Pn max)	%	2,38		2,35		2,41		2,44	
Chimney losses with burner off	%	0,06		0,05		0,04		0,03	

DESCRIPTION	U.M.	POWER EVO-X								
		50 DEP		50		65		80		
		G20	G31	G20	G31	G20	G31	G20	G31	
Gas type										
Shell losses with burner on (Pn max)	%	0,22		0,15		0,09		0,06		
FLUE GAS SYSTEMS										
NOx class - UNI EN 15502		6		6		6		6		
Residual head of concentric tubes 0,85 m Ø60-100 mm	Pa	60		60		ND		ND		
Residual headroom separated pipes 0,5 m Ø80 mm	Pa	160		192		172		197		
Residual boiler head without pipes and without flange	Pa	166		198		180		200		
ELECTRICAL CHARACTERISTICS										
Max heating electric power	W	158		175		201		284		
Burner electrical power P max	W	60		77		113		196		
Electric power circulator max	W	98		98		88		88		
Electrical power circulator min	W	3		3		5		5		
Power supply	V - Hz	230-50		230-50		230-50		230-50		
Electrical protection level	IP	X5D		X5D		X5D		X5D		
HEATING OPERATION										
Maximum pressure	bar	5		5		5		5		
Minimum pressure for standard operation	bar	0,8		0,8		0,8		0,8		
Maximum temperature:	°C	90		90		90		90		
H ₂ O heating temperature selection range.	°C	20/45 - 20/90		20/45 - 20/90		20/45 - 20/90		20/45 - 20/90		
Pump: max head available to the system at flow rate of	mbar l/h	820 1000		820 1000		430 2500		430 2500		
AIR AND FLUES FLOW RATES										
Heating										
Air flow rate	Nm ³ /h	42,4	43,3	54,7	55,8	66,8	68,2	85,0	86,9	
Flues flow rate	Nm ³ /h	45,9	46,0	59,2	59,3	72,3	72,5	92,0	92,3	
Flue gas mass flow rate (max-min)	g / s	15,8-2,4	16,2-2,4	20,4-2,4	20,9-2,4	24,9-3,7	25,5-3,8	31,8-3,7	32,5-3,8	
DOMESTIC WATER										
Air flow rate	Nm ³ /h	42,4	43,3	54,7	55,8	66,8	68,2	85,0	86,9	
Flues flow rate	Nm ³ /h	45,9	46	59,2	59,3	72,3	72,5	92	92,3	
Flue gas mass flow rate (max-min)	g / s	15,8-2,4	16,2-2,4	20,4-2,4	20,9-2,4	24,9-3,7	25,5-3,8	31,8-3,7	32,5-3,8	
EMISSION VALUES AT MAX AND MIN FLOW RATE WITH G20 GAS (**)										
Maximum										
CO s.a. less than	p.p.m	120	130	150	160	170	170	220	230	
CO ₂	%	9,0	10,0	9,0	10,0	9,0	10,0	9,0	10,0	
NOx s.a. less than	p.p.m	50	50	60	60	50	50	60	60	
Flues temperature	°C	68	66	71	73	66	70	70	76	
Minimum										
CO s.a. less than	p.p.m	30	30	30	30	40	20	40	20	
CO ₂	%	9,0	10,0	9,0	10,0	9,0	10,0	9,0	10,0	
NOx s.a. less than	p.p.m	40	45	40	45	40	60	40	60	
Flues gas temperature	°C	60	58	60	58	57	58	57	58	

(*) Average value among the various operating conditions in DHW.

(**) Verification performed with concentric pipe 60-100 mm-length 0.85 m-water temperature 80-60°C.

Note

With reference to the Delegated Regulation (EU) No. 811/2013, the data represented in the table can be used for the completion of the product data sheet and labeling for room heating appliances, mixed heating appliances, assemblies of room heating appliances, temperature control devices and solar devices:

	CLASS	BONUS
EXTERNAL PROBE	II	2%
REMOTE CONTROL OT+	V	3%
OUTDOOR PROBE + REMOTE CONTROL OT+	VI	4%

ERP regulation technical data table

Parameter	Symbol	Unit	POWER EVO-X			
			50 DEP	50	65	80
Seasonal efficiency class in central heating mode	-	-	A	A	A	A
Seasonal efficiency class in water heating	-	-	ND	ND	ND	ND
Useful (rated) heat output	Pnominal	kW	34	44	54	68
Seasonal efficiency class in room heating mode	η_s	%	93	92	92	92
Useful heat output Pn						
At useful heat output and at high temperature capacity (*)	P4	kW	34,0	43,9	53,6	68,2
At 30% of useful heat output and at low temperature capacity P1 (HHV)	P1	kW	11,3	14,6	17,8	22,6
Efficiency						
At useful heat output and at high temperature capacity (*)	η_4	%	87,7	87,8	87,8	87,8
At 30% of useful heat output and at low temperature capacity P1 (HHV)	η_1	%	97,4	97,2	96,9	96,8
Other parameters						
Thermal losses in Stand-by mode	Pstby	W	36,8	34,7	34,5	34,5
Pilot flame energy consumption	Pign	W	-	-	-	-
Yearly energy consumption	QHE	GJ	105	137	168	214
Noise level, indoor (sound power)	LWA	dB	57	60	57	61
Nitrogen oxide emissions (NOx)	NOx	mg/kWh	30	33	41	48
Domestic hot water						
Declared load profile			ND	ND	ND	ND
Energy efficiency class in water heating	η_{wh}	%	ND	ND	ND	ND
Daily electrical energy consumption	Qelec	kWh	ND	ND	ND	ND
Daily fuel consumption	Qfuel	kWh	ND	ND	ND	ND
Annual electrical energy consumption	AEC	kWh	ND	ND	ND	ND
Annual fuel consumption	AFC	GJ	ND	ND	ND	ND

(*) High temperature regime: 60°C return and 80°C boiler flow.

(*) Low temperature regime: for condensing boilers 30°C, for low temperature boilers 37°C, for other heating appliances 50°C return temperature.

Overall dimensions and weights

POWER EVO-X 50 DEP - 50

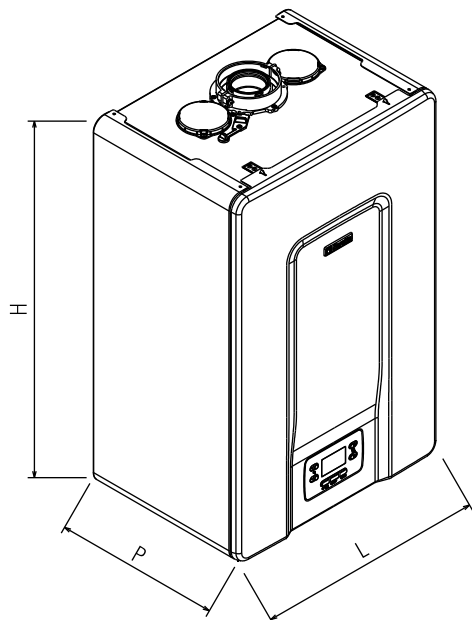

POWER EVO-X 65 - 80

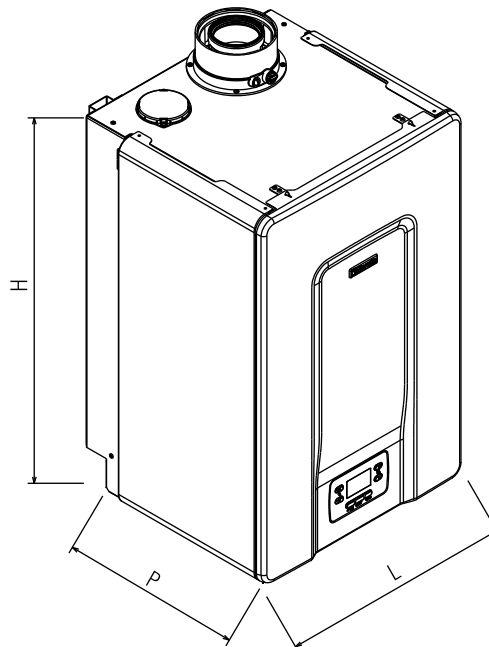

DESCRIPTION	U.M.	POWER EVO X			
		50 DEP	50	65	80
L	mm	470	470	470	470
P	mm	350	350	443	443
H	mm	740	740	740	740
Net weight	kg	35	35	53,5	53,5

POWER MAX

Product Description

POWER MAX is Beretta's new proposal as a modular wall-mounted condensing system, capable of the highest level of performance and covering a wide range of applications, with the possibility of indoor or outdoor installation, with open- or sealed-chamber combustion, with single or cascade boilers up to 1120 kW.

The range consists of 6 models with thermal modules from 57 up to 131 kW. Each thermal module is equipped with the innovative heat exchanger with patented geometries, consisting of two concentric stainless steel smooth tubes, having pentagonal cross-section the inside and circular cross-section the outside, respectively, designed to maximize the exchange surface, offer maximum corrosion resistance.

The primary circuit pump with modulating control allows operation with settable constant Dt, reducing system set-up time and maximizing condensation. Basic electronics include climate control, module cascade management, with built-in master/slave functions, automatic summer/winter switching, and the ability to manage a direct zone and a DHW tank.

The electronics also offers the possibility of remote control via 0-10V input or with the Modbus protocol. Included as standard are: boiler drain cock, safety valves, LPG conversion kit and wall bracket. Completing the system are accessories specifically designed for modular and cascade applications, with the possibility of working with different hydraulic management logics, i.e., thermal modules with circulators, 2-way valves or no shut-off. Through special accessories there is also the possibility of managing the distribution of the secondary circuit, up to 16 mixed zones.

Optimal combustion management and high modulation ratios, up to 1:50 for the version with 10 thermal modules, enable high efficiency and low pollutant emissions (Class 6 according to UNI EN 15502).

- Designed to operate with mixtures of natural gas and hydrogen, up to a maximum of 20%.
- Modulation ratio 1:8 in single installation, up to 1:32 in battery installation.
- Modulating circulator with high head and low consumption.
- Maximum operating pressure 5 bar.
- Ease of installation.
- Wide range of accessories to complete single and battery installation in both linear and back-to-back configurations.

Technical data

DESCRIPTION	U.M.	POWER MAX	
		65 P	80 P
Material		STEEL	STEEL
Efficiency class		> 93 + 2 log Pn	> 93 + 2 log Pn
Gas type		NG-LPG	NG-LPG
Test room temperature	°C	20	20
Max. rated heat input at furnace (LCV)	kW	57,0	68,0
Min. rated heat input at furnace (LCV)	kW	14,0	14,0
Max. rated heat output (80÷60°C)	kW	55,7	67,0
Min. rated heat output (80÷60°C)	kW	13,5	13,5
Max. rated heat output (50÷30°C)	kW	61,9	73,9
Min. rated heat output (50÷30°C)	kW	14,9	14,9
Efficiency at max. rated heat output (80÷60°C)	%	98,3	98,1
Efficiency at min. rated heat output (80÷60°C)	%	98,9	98,9
Efficiency at max. rated heat output (50÷30°C)	%	108,6	108,1
Efficiency at min. rated heat output (50÷30°C)	%	109,3	109,3
Useful efficiency at 30%	%	109,2	109,0
Heat loss in standby mode	%	0,1	0,1
Chimney losses with burner on at P.max	%	2,3	2,3
Chimney losses with burner on at P.min	%	0,1	0,1
Blanket losses with burner on with 70°C average temperature	%	0,9	0,9
Blanket losses with burner off with 70°C average temperature	%	0,9	0,9
Flue gas temperature at max/min. power 80÷60°C	°C	71,0 / 61,0	72,0 / 61,0
Flue gas temperature at max/min. power 50÷30°C	°C	45,0 / 33,0	46,0 / 33,0

DESCRIPTION	U.M.	POWER MAX	
		65 P	80 P
Excess air at max.power		1,27	1,27
Excess air at min.power		1,27	1,27
Max-min flue gas mass flow rate	kg/s	0,0250-0,0070	0,0300-0,0070
Available useful discharge head P.max	Pa	510	630
Available useful discharge head P.min	Pa	35	35
Flue side pressure drop	mbar	-	-
NOx	mg/kWh	34,2	36,4
Water-side pressure losses with ΔT 20°C	mbar	-	-
Residual head on the water side with ΔT 20°C	mbar	490	390
Water-side pressure losses with ΔT 10°C	mbar	-	-
Residual head on the water side with ΔT 10°C	mbar	-	-
Water content	l	15	15
Maximum working pressure	bar	6	6
Expansion tank capacity	l	-	-
Power supply	V/Hz	230-50	230-50
Electrical protection level	IP	IPX4D	IPX4D
Electrical consumption with boiler at max. power	W	63	77
Electrical consumption with boiler at min. power	W	30	30
Electrical consumption with pumps at max. power	W	-	-
Electrical consumption with pumps at min. power	W	-	-
Flue gas discharge diameter	mm	80	80
Empty weight	kg	78	78
Category according to UNI 10642		II 2H3P appliance	II 2H3P appliance
Boiler water content	l	-	-
Boiler losses	W/K	-	-
Boiler material		-	-
Insulation thickness	mm	-	-
Boiler circulator absorption	W	-	-
Sanitary expansion vessel	l	-	-
Noise	dB(A)	53	54
Nominal/min natural gas pressure supply (G20)	mbar	20 / 17	20 / 17
Nominal/min gas pressure supply (G31)	mbar	37 / 25	37 / 25

Technical data

DESCRIPTION	U.M.	POWER MAX			
		100	110	130	150
Material		STEEL	STEEL	STEEL	STEEL
Efficiency class		> 93 + 2 log Pn	> 93 + 2 log Pn	> 93 + 2 log Pn	> 93 + 2 log Pn
Gas type		NG-LPG	NG-LPG	NG-LPG	NG-LPG
Flue systems installation type	°C	20	20	20	20
Max. rated heat input at furnace (LCV)	kW	90,0	97,0	112,0	131,0
Min. rated heat input at furnace (LCV)	kW	19,4	19,4	22,4	26,2
Max. rated heat output (80÷60°C)	kW	88,3	95,2	109,8	129,0
Min. rated heat output (80÷60°C)	kW	19,2	19,2	22,1	26,0
Max. rated heat output (50÷30°C)	kW	97,4	105,1	121,1	142,1
Min. rated heat output (50÷30°C)	kW	21,1	21,1	24,5	28,9
Efficiency at max. rated heat output (80÷60°C)	%	98,2	98,1	98,5	98,3
Efficiency at min. rated heat output (80÷60°C)	%	98,8	98,8	99,2	99,1
Efficiency at max. rated heat output (50÷30°C)	%	108,3	108,2	108,6	108,3
Efficiency at min. rated heat output (50÷30°C)	%	109,2	109,2	110,0	110,0
Useful efficiency at 30%	%	109,1	109,0	109,0	109,1
Heat loss in standby mode	%	0,1	0,1	0,1	0,1
Chimney losses with burner on at P.max	%	2,5	2,6	2,5	2,6
Chimney losses with burner on at P.min	%	0,2	0,2	0,1	0,1
Blanket losses with burner on with 70°C average temperature	%	0,9	0,9	0,9	0,9
Blanket losses with burner off with 70°C average temperature	%	0,9	0,9	0,9	0,9
Flue gas temperature at max/min. power 80÷60°C	°C	76,0 / 62,0	78,0 / 62,0	75,0 / 61,0	77,0 / 61,0
Flue gas temperature at max/min. power 50÷30°C	°C	47,0 / 35,0	49,0 / 35,0	45,0 / 33,0	48,0 / 35,0
Excess air at max.power		1,27	1,27	1,27	1,27
Excess air at min.power		1,27	1,27	1,27	1,27
Max-min flue gas mass flow rate	kg/s	0,0400-0,0072	0,0460-0,0072	0,0500-0,0100	0,0600-0,0110
Available useful discharge head P.max	Pa	560	610	500	353
Available useful discharge head P.min	Pa	32	32	30	28
Flue side pressure drop	mbar	-	-	-	-
NOx	mg/kWh	38,1	38,7	39,3	46,1
Water-side pressure losses with ΔT 20°C	mbar	160	210	350	510
Residual head on the water side with ΔT 20°C	mbar	-	-	-	-
Water-side pressure losses with ΔT 10°C	mbar	-	-	-	-
Residual head on the water side with ΔT 10°C	mbar	-	-	-	-
Water content	l	17	17	23	25
Maximum working pressure	bar	6	6	6	6
Expansion tank capacity	l	-	-	-	-
Power supply	V/Hz	230-50	230-50	230-50	230-50
Electrical protection level	IP	IPX4D	IPX4D	IPX4D	IPX4D
Electrical consumption with boiler at max. power	W	150	203	205	302
Electrical consumption with boiler at min. power	W	36	31	44	45
Electrical consumption with pumps at max. power	W	-	-	-	-
Electrical consumption with pumps at min. power	W	-	-	-	-
Flue gas discharge diameter	mm	110	110	110	110
Empty weight	kg	81	81	93	97
Category according to UNI 10642		II 2H3P appliance	II 2H3P appliance	II 2H3P appliance	II 2H3P appliance
Boiler water content	l	-	-	-	-
Boiler losses	W/K	-	-	-	-
Boiler material		-	-	-	-
Insulation thickness	mm	-	-	-	-
Boiler circulator absorption	W	-	-	-	-
Sanitary expansion vessel	l	-	-	-	-
Noise	dB(A)	55	56	57	57
Nominal/min natural gas pressure supply (G20)	mbar	20 / 17	20 / 17	20 / 17	20 / 17
Nominal/min gas pressure supply (G31)	mbar	37 / 25	37 / 25	37 / 25	37 / 25

ERP regulation technical data table

Parameter	Simbol	Unit	POWER MAX	
			65 P	80 P
Seasonal efficiency class in central heating mode			A	A
Seasonal efficiency class in water heating			-	-
Useful (rated) heat output	Pnominal	kW	56	68
Seasonal efficiency class in room heating mode	η_s	%	94	94
Useful heat output Pn				
At useful heat output and at high temperature capacity (*)	P4	kW	55,7	67
At 30% of useful heat output and at low temperature capacity P1 (HHV)	P1	kW	18,7	22,3
Efficiency				
At useful heat output and at high temperature capacity (*)	η_4	%	88,4	88,2
At 30% of useful heat output and at low temperature capacity P1 (HHV)	η_1	%	98,2	98,0
Auxiliary electrical consumption				
At full load	elmax	W	63	77
At partial load	elmin	W	30	30
In standby mode	PSB	W	13	13
Other parameters				
Thermal losses in Stand-by mode	Pstby	W	72,0	87,0
Pilot flame energy consumption	Pign	W	-	-
Yearly energy consumption	QHE	GJ	117	141
Noise level, indoor (sound power)	LWA	dB	53	54
Nitrogen oxide emissions (NOx)	NOx	mg/kWh	34,2	36,4
For heating combi boilers				
Declared load profile				
Energy efficiency class in water heating	wh	%	-	-
Daily electrical energy consumption	Qelec	kWh	-	-
Daily fuel consumption	Qfuel	kWh	-	-
Annual electrical energy consumption	AEC	kWh	-	-
Annual fuel consumption	AFC	GJ	-	-

MAX - BOX monobloc hybrid systems

Parameter	Simbol	Unit	POWER MAX			
			100	110	130	150
Seasonal efficiency class in central heating mode			-	-	-	-
Seasonal efficiency class in water heating			-	-	-	-
Useful (rated) heat output	Pnominal	kW	88	95	110	129
Seasonal efficiency class in room heating mode	η_s	%	94	94	94	94
Useful heat output Pn						
At useful heat output and at high temperature capacity (*)	P4	kW	88,3	95,3	109,8	129,0
At 30% of useful heat output and at low temperature capacity P1 (HHV)	P1	kW	29,4	31,7	36,6	43,0
Efficiency						
At useful heat output and at high temperature capacity (*)	η_4	%	88,3	88,2	88,6	88,2
At 30% of useful heat output and at low temperature capacity P1 (HHV)	η_1	%	98,1	98,0	98,0	98,1
Auxiliary electrical consumption						
At full load	elmax	W	150	203	205	302
At partial load	elmin	W	36	31	44	45
In standby mode	PSB	W	6	6	6	8
Other parameters						
Thermal losses in Stand-by mode	Pstby	W	115,0	124,0	143,0	168,0
Pilot flame energy consumption	Pign	W	-	-	-	-
Yearly energy consumption	QHE	GJ	-	-	-	-
Noise level, indoor (sound power)	LWA	dB	55	56	57	57
Nitrogen oxide emissions (NOx)	NOx	mg/kWh	38,1	38,7	39,3	46,1
For heating combi boilers						
Declared load profile						
Energy efficiency class in water heating	η_{wh}	%	-	-	-	-
Daily electrical energy consumption	Qelec	kWh	-	-	-	-
Daily fuel consumption	Qfuel	kWh	-	-	-	-
Annual electrical energy consumption	AEC	kWh	-	-	-	-
Annual fuel consumption	AFC	GJ	-	-	-	-

Overall dimensions and weights

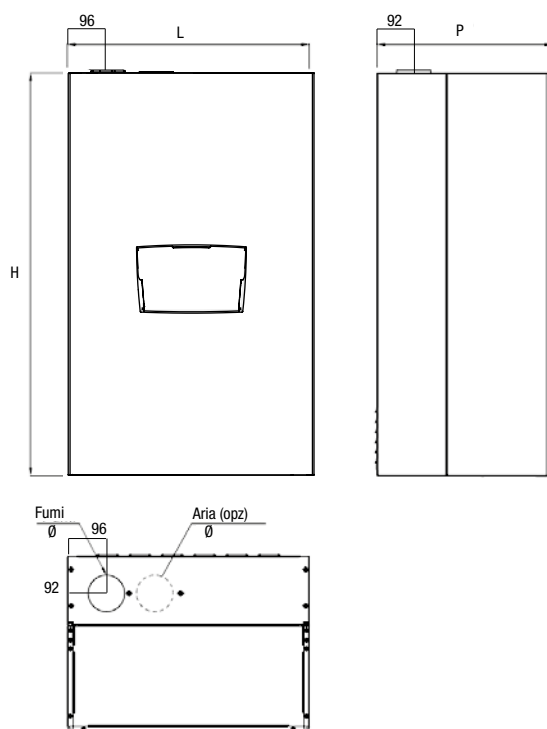

Model	H mm	L mm	P mm	flues gas/air Ø mm	Net weight kg
POWER MAX 65 P	1000	600	435	80	78
POWER MAX 80 P	1000	600	435	80	78
POWER MAX 100	1000	600	435	110	81
POWER MAX 110	1000	600	435	110	81
POWER MAX 130	1165	600	435	110	93
POWER MAX 150	1165	600	435	110	97

POWER MAX BOX

Product Description

POWER MAX BOX is Beretta's new modular condensing system, specially designed and developed to achieve very high energy efficiency values while minimizing the space occupied.

The system, ready for quick and easy installation, consists of technical cabinets designed according to the principles of modularity, composed of an assembled anodized aluminum frame and painted panels.

The standard product is suitable for indoor installation, with open chamber combustion; it can be converted to sealed combustion or to a version for outdoor installation with the installation of specific accessory kits.

Cabinets are equipped with 2, 3, or 4 thermal elements from 57 up to 131 kW, for a total capacity from 114 up to 524 kW. Each thermal module is associated with a low-consumption circulator with modulating water flow control, which can maintain a constant ΔT° between supply and return and maximize condensation and efficiency.

The range also includes as standard the electronic management and control regulation, hydraulic supply and return manifolds, gas, flue gas and condensate drainage manifolds.

The heat exchangers, with patented geometries, consist of two smooth concentric stainless steel tubes, having a pentagonal cross-section the inside and a circular cross-section the outside, respectively; they have been specially designed to maximize the exchange surface area, offer maximum corrosion resistance and minimum pressure drop. These features allow them to work with high ΔT , enabling reduced plant set-up times. models with 131 kW exchanger (300-450-600) are prepared for cascade installation, with side-by-side coupling, up to a maximum of 10 units in total and an output of 1310 kW.

The control electronics, compatible with MOD-BUS protocol, allows climate control with cascade management of thermal modules, automatic summer/winter switching, the possibility of remote management via 0..10V input and alarm signal output.

The control system manages heat distribution on the secondary circuit, controlling: a direct zone, one or more mixed zones (1 to 3 depending on the model), and the boiler circuit.

Through special accessories there is also the possibility of managing additional mixed zones (up to a maximum of 16).

Optimal combustion management and high modulation ratios (up to 1:50) enable high efficiency and low pollutant emissions (Class 6 according to UNI EN 15502).

Service continuity is guaranteed by the system modularity: even in the case of a module failure, the overall operation it is not prejudiced

Accessories designed to ensure simple, quick and complete installation of the central heating unit are also available.

- Service continuity is guaranteed by the system modularity: even in the case of a module failure, the overall operation it is not prejudiced
- The anti-freeze and anti-seize functions ensure operation in all weather conditions
- A wide range of accessories is available to ensure simple, fast and complete cascade installation.
- Maximum working pressure: 6 bar.

Technical data

DESCRIPTION	U.M.	POWER MAX BOX									
		130-2		160-2		200-2		260-2		300-2	
		G20	G31	G20	G31	G20	G31	G20	G31	G20	G31
Appliance type											
Type		Condensing heating B23, B53; B53P									
Gas type		G20-G25-G30-G31									
Combustion chamber		Vertical									
Flue systems installation type		B23, B23P, B53P, C13(*), C33(*), C53(*), C63(*)									
Appliance category according to UNI 10642		II2H3P									
OUTPUTS AND EFFICIENCIES											
Maximum rated heat input at furnace LHV	kW	114,00		136,00		180,00		223,20		262,00	
Maximum rated heat input at furnace HHV	kW	126,0	ND	152,0	ND	200,0	ND	248,0	ND	292,0	ND
Maximum useful heat output 80±60°C	kW	111,4	ND	134,0	ND	176,6	ND	219,6	ND	258,0	ND
Maximum useful heat output 60±40°C	kW	119,2	ND	142,8	ND	187,6	ND	232,4	ND	274,6	ND
Maximum useful heat output 50±30°C	kW	123,8	ND	147,8	ND	194,8	ND	242,2	ND	284,2	ND
Minimum thermal flow rate PCI	kW	13,7	ND	13,7	ND	19,4	ND	22,4	ND	26,3	ND

DESCRIPTION	U.M.	POWER MAX BOX									
		130-2		160-2		200-2		260-2		300-2	
		G20	G31	G20	G31	G20	G31	G20	G31	G20	G31
Minimum heat flow rate PCS	kW	15,0	ND	15,0	ND	21,6	ND	24,9	ND	29,0	ND
Minimum heat output 80÷60°C	kW	13,5	ND	13,5	ND	19,2	ND	22,1	ND	26,0	ND
Minimum heat output 50÷30°C	kW	14,9	ND	14,9	ND	21,1	ND	24,5	ND	28,9	ND
Efficiency with nominal heat output 80÷60°C (LHV)	%	97,72		98,53		98,11		98,40		98,47	
Efficiency with minimum heat output 80÷60°C (LHV)	%	98,90		98,90		98,80		99,20		99,10	
Efficiency with nominal heat output 50÷30°C (LHV)	%	108,60		108,10		108,30		108,60		108,30	
Efficiency with minimum heat output 50÷30°C (LHV)	%	109,30		109,30		109,20		110,00		110,00	
Efficiency at 30% 50÷30°C HHV (LHV)	%	98,94 (109,36)		97,81 (109,31)		98,00 (108,89)		98,39 (108,93)		98,17 (109,41)	
Combustion efficiency	%	99,0		99,3		99,3		99,3		99,3	
Chimney losses with burner off	%	0,10		0,10		0,10		0,10		0,10	
Chimney losses with burner on P.max 80÷60°C	%	2,30		2,30		2,50		2,50		2,60	
Losses at the chimney burner ignited at 30% Pn 50÷30°C	%	0,50		0,50		0,60		0,50		0,60	
Chimney losses with burner on P.min 80÷60°C	%	0,12		0,11		0,22		0,10		0,10	
Blanket losses with burner on with 70°C average temperature	%	0,50		0,50		0,50		0,50		0,50	
Blanket losses with burner off with 70°C average temperature	%	0,50		0,50		0,50		0,50		0,50	
Flue gas temperature at max power and min power 80÷60°C	°C	71 - 61		72 - 61		76 - 62		75 - 61		77 - 61	
Flue temperature at max and min heat output 50÷30°C	°C	45 - 33		46 - 33		47 - 35		45 - 33		48 - 35	
Air index λ at max power	no.	1,27	1,29	1,27	1,29	1,27	1,29	1,27	1,29	1,27	1,29
Air index λ at min power	no.	1,27	1,29	1,27	1,29	1,27	1,29	1,27	1,29	1,27	1,29
Flue gas mass flow rate at max-min power	g/s	53-6	51-6	64-6	62-6	84-9	82-9	104-10	101-10	122-12	119-12
Flue residual head at P.min	Pa	35,00		35,00		32,00		30,00		28,00	
Flue residual head at P.max	Pa	510,00		630,00		560,00		500,00		353,00	
ELECTRICAL DATA											
Power supply	V-Hz						230-50				
Electrical protection level	IP						IPX4D				
Electric power consumption of boiler with max	W	198		264		460		706		964	
Boiler electrical power input at min power	W	92		96		126		198		220	
Electric power input pumps at max power	W	100		110		160		296		360	
Electrical power input pumps at min power	W	40		44		64		118		144	
HEATING OPERATION											
Water temperature selection range (with plate heat exchanger)	°C						20-80/(85)*				
Safety thermostat intervention temperature	°C						95				
Maximum operating temperature	°C						100				
Maximum working pressure	bar						6				
Minimum working pressure	bar						0,7				
Water content	l	45,00		45,00		50,00		60,00		75,00	
Water-side pressure losses with ΔT 20°C "V versions"	mbar	102		135		168		356		526	
Residual head on water side with ΔT 20°C "P versions"	mbar	400		280		450		300		500	
Maximum condensate production at maximum power 50÷30°C	l/h	17,80		20,20		27,20		35,00		39,60	
Noise (sound power)	dB(A)	56		58		58		60		61	

MAX - BOX monobloc hybrid systems

DESCRIPTION	U.M.	POWER MAX BOX									
		130-2		160-2		200-2		260-2		300-2	
		G20	G31	G20	G31	G20	G31	G20	G31	G20	G31
GAS SUPPLY DATA											
Maximum gas supply pressure	mbar	60	60	60	60	60	60	60	60	60	60
Gas supply pressure rating	mbar	20	37	20	37	20	37	20	37	20	37
Minimum gas supply pressure	mbar	17	25	17	25	17	25	17	25	17	25
DIMENSION DATA											
Heating flow diameter	Ø DN	3" DN80 PN6		3" DN80 PN6		3" DN80 PN6		3" DN80 PN6		5" DN125 PN6	
Heating Return diameter	Ø DN	3" DN80 PN6		3" DN80 PN6		3" DN80 PN6		3" DN80 PN6		5" DN125 PN6	
Gas inlet diameter	Ø DN	2" DN50 PN6		2" DN50 PN6		2" DN50 PN6		2" DN50 PN6		3" DN80 PN6	
Condensate drain	Ø mm	50		50		50		50		50	
Boiler height	mm	1800		1800		1800		1800		1800	
Boiler width	mm	900		900		900		900		900	
Boiler depth	mm	890		890		890		890		890	
Flue discharge diameter	Ø mm	DN160		DN160		DN160		DN160		DN300/DN160	
Air intake diameter (optional)	Ø mm	DN160		DN160		DN160		DN160		DN300	
Empty weight	kg	270		270		280		300		350	

(*) Configurations possible only with installation of dedicated accessories (available separately).

(**) Weight values calculated according to EN 15502.

(***) Values referred to atmospheric pressure at sea level.

Technical data

DESCRIPTION	U.M.	POWER MAX BOX									
		330-3		390-3		450-3		520-4		600-4	
		G20	G31	G20	G31	G20	G31	G20	G31	G20	G31
Appliance type											
Type		Condensing heating B23, B53; B53P									
Gas type		G20-G25-G30-G31									
Combustion chamber		Vertical									
Flue systems installation type		B23, B23P, B53P, C13(*), C33(*), C53(*), C63(*)									
Appliance category according to UNI 10642		II2H3P									
OUTPUTS AND EFFICIENCIES											
Maximum rated heat input at furnace LHV	kW	291,00	ND	336,00	ND	393,00	ND	446,40	ND	524,00	ND
Maximum rated heat input at furnace HHV	kW	324,0	ND	372,0	ND	438,0	ND	496,0	ND	584,0	ND
Maximum useful heat output 80÷60°C	kW	285,9	ND	329,4	ND	387,0	ND	439,2	ND	516,0	ND
Maximum useful heat output 60÷40°C	kW	303,3	ND	348,6	ND	411,9	ND	464,8	ND	549,2	ND
Maximum useful heat output 50÷30°C	kW	315,3	ND	363,6	ND	426,3	ND	484,4	ND	568,4	ND
Minimum thermal flow rate PCI	kW	19,4	ND	22,4	ND	26,3	ND	22,4	ND	26,3	ND
Minimum heat flow rate PCS	kW	21,6	ND	24,9	ND	29,0	ND	24,9	ND	29,0	ND
Minimum heat output 80÷60°C	kW	19,2	ND	22,1	ND	26,0	ND	22,1	ND	26,0	ND
Minimum heat output 50÷30°C	kW	21,1	ND	24,5	ND	28,9	ND	24,5	ND	28,9	ND
Efficiency with nominal heat output 80÷60°C (LHV)	%	98,25		98,4		98,47		98,40		98,47	
Efficiency with minimum heat output 80÷60°C (LHV)	%	98,80		99,20		99,10		99,20		99,10	
Efficiency with nominal heat output 50÷30°C (LHV)	%	108,20		108,60		108,30		108,60		108,30	
Efficiency with minimum heat output 50÷30°C (LHV)	%	109,20		110,00		110,00		110,00		110,00	
Efficiency at 30% 50÷30°C HHV (LHV)	%	97,84 (108,93)		98,39 (108,93)		98,17 (109,41)		98,39 (108,93)		98,17 (109,41)	
Combustion efficiency	%	99,0		99,0		99,0		99,3		99,3	
Chimney losses with burner off	%	0,10		0,10		0,10		0,10		0,10	
Chimney losses with burner on P.max 80÷60°C	%	2,60		2,50		2,60		2,50		2,60	
Losses at the chimney burner ignited at 30% Pn 50÷30°C	%	0,60		0,50		0,60		0,50		0,60	
Chimney losses with burner on P.min 80÷60°C	%	0,20		0,10		0,10		0,10		0,10	
Blanket losses with burner on with 70°C average temperature	%	0,33		0,33		0,33		0,25		0,25	
Blanket losses with burner off with 70°C average temperature	%	0,33		0,33		0,33		0,25		0,25	
Flue gas temperature at max power and min power 80÷60°C	°C	78 - 62		75 - 61		77 - 61		75 - 61		77 - 61	
Flue temperature at max and min heat output 50÷30°C	°C	49 - 35		45 - 33		48 - 35		45 - 33		48 - 35	
Air index λ at max power	no.	1,27	1,29	1,27	1,29	1,27	1,29	1,27	1,29	1,27	1,29
Air index λ at min power	no.	1,27	1,29	1,27	1,29	1,27	1,29	1,27	1,29	1,27	1,29
Flue gas mass flow rate at max-min power	g/s	136-9	132-9	156-10	152-10	183-12	179-12	208-10	203-10	245-12	238-12
Flue residual head at P.min	Pa	32,00		30,00		28,00		30,00		28,00	
Flue residual head at P.max	Pa	610,00		500,00		353,00		500,00		353,00	
ELECTRICAL DATA											
Power supply	V-Hz	230-50									
Electrical protection level	IP	IPX4D									
Electric power consumption of boiler with max	W	951		1059		1446		1412		1928	
Boiler electrical power input at min power	W	228		297		330		396		440	
Electric power input pumps at max power	W	342		444		540		592		720	
Electrical power input pumps at min power	W	135		177		216		236		288	

MAX - BOX monobloc hybrid systems

DESCRIPTION	U.M.	POWER MAX BOX									
		330-3		390-3		450-3		520-4		600-4	
		G20	G31	G20	G31	G20	G31	G20	G31	G20	G31
HEATING OPERATION											
Water temperature selection range (with plate heat exchanger)	°C	20-80/(85)*									
Safety thermostat intervention temperature	°C	95									
Maximum working temperature	°C	100									
Maximum working pressure	bar	6									
Minimum working pressure	bar	0,7									
Water content	l	80,00		100,00		120,00		120,00		150,00	
Water-side pressure losses with ΔT 20°C "V versions"	mbar	230		356		526		356		526	
Residual head on water side with ΔT 20°C "P versions"	mbar	300		300		500		300		500	
Maximum condensate production at maximum power 50÷30°C	l/h	45,00		52,50		59,40		70,00		79,20	
Noise (sound power)	dB(A)	60		61		62		63		64	
GAS SUPPLY DATA											
Maximum gas supply pressure	mbar	60	60	60	60	60	60	60	60	60	60
Gas supply pressure rating	mbar	20	37	20	37	20	37	20	37	20	37
Minimum gas supply pressure	mbar	17	25	17	25	17	25	17	25	17	25
DIMENSION DATA											
Heating flow diameter	Ø DN	3" DN80 PN6		3" DN80 PN6		5 "DN125		3" DN80 PN6		5 "DN125	
Heating Return diameter	Ø DN	3" DN80 PN6		3" DN80 PN6		5 "DN125		3" DN80 PN6		5 "DN125	
Gas inlet diameter	Ø DN	2" DN50 PN6		2" DN50 PN6		3" DN80 PN6		2" DN50 PN6		3" DN80 PN6	
Condensate drain	Ø mm	50		50		50		50		50	
Boiler height	mm	1800		1800		1800		1800		1800	
Boiler width	mm	1800		1800		1800		1800		1800	
Boiler depth	mm	890		890		890		890		890	
Flue discharge diameter	Ø mm	DN160		DN160		DN300/DN160		DN160		DN300	
Air intake diameter (optional)	Ø mm	DN160		DN160		DN300		DN160		DN300	
Empty weight	kg	450		490		540		560		600	

(*) Configurations possible only with installation of dedicated accessories (available separately).

(**) Weight values calculated according to EN 15502.

(***) Values referred to atmospheric pressure at sea level.

ERP regulation technical data table

POWER MAX BOX 130-2 / 160-2 / 200-2 / 260-2 / 300-2

Parameter			Unit	POWER MAX BOX				
				130-2	160-2	200-2	260-2	300-2
Useful (rated) heat output			kW	114,0	136,0	180,0	223,2	262,0
Seasonal efficiency class in room heating mode	η_s		%	94	93	93	93	93
Useful heat output P_n								
At useful heat output and at high temperature capacity (*)	P4	G20	kW	114,0	134,0	176,6	219,6	258,0
At 30% of useful heat output and at low temperature capacity P1 (HHV)	P1	G20	kW	37,4	44,6	58,8	73,2	86,6
Efficiency								
At useful heat output and at high temperature capacity (*)	η_4	G20	%	88,41	88,16	88,30	88,55	88,36
At 30% of useful heat output and at low temperature capacity P1 (HHV)	η_1	G20	%	98,94	97,81	98,00	98,39	98,17
Auxiliary electrical consumption								
At full load	elmax		W	198	264	460	706	964
At partial load	elmin		W	92	96	126	198	220
In standby mode	PSB		W	26	26	12	12	16
Other parameters								
Thermal losses in Stand-by mode	Pstby		W	159,16	194,47	255,56	316,64	374,47
Pilot flame energy consumption	QHE		GJ	236	282	364	384	532,0
Yearly energy consumption	LWA		dB(A)	56	58	58	60	61,00
Noise level, indoor (sound power)			mg/kWh	34,20	36,40	38,10	39,30	46,10
Nitrogen oxide emissions (NO _x)				6	6	6	6	6
EMISSION VALUES AT MAX GAS FLOW *								
CO s.a. less than	G20	p.p.m.		79,0	90,0	81,0	89,0	91,5
	G31			142,0	147,0	153,0	177,0	185
CO ₂ **	G20	%		9,0	9,0	9,0	9,0	9,0
	G31			10,4	10,4	10,4	10,4	10,4
NO _x s.a. less than	G20	p.p.m.		30	30	30	30	30
	G31			40	40	40	40	40
Flues temperature			°C	71,0	72,0	76,0	75,0	77,0
EMISSION VALUES AT MIN GAS FLOW								
CO s.a. less than	G20	p.p.m.		6,5	6,5	7,5	4,6	5,6
	G31			11,0	11,0	12,0	14,0	16,0
CO ₂ **	G20	%		9,0	9,0	9,0	9,0	9,0
	G31			10,4	10,5	10,4	10,4	10,4
NO _x s.a. less than	G20	p.p.m.		30	30	30	30	30
	G31			40	40	40	40	40
Flues temperature			°C	61,0	61,0	62,0	61,0	61,0

* Values calculated according to UNI EN 15502 standard.

** Values referring to atmospheric pressure at sea level.

POWER MAX BOX 330-3 / 390-3 / 450-3 / 520-4 / 600-4

Parameter	Unit		POWER MAX BOX					
			330-3	390-3	450-3	520-4	600-4	
Useful (rated) heat output		kW	291,0	334,8	393,0	446,4	524,0	
Seasonal efficiency class in room heating mode	ηs	%	93	93	93	93	93	
Useful heat output Pn								
At useful heat output and at high temperature capacity (*)	P4	G20	kW	285,9	329,4	387,0	439,2	516,0
At 30% of useful heat output and at low temperature capacity P1 (HHV)	P1	G20	kW	95,1	109,8	129,0	146,4	172,0
Efficiency								
At useful heat output and at high temperature capacity (*)	η4	G20	%	88,24	88,55	88,36	88,55	88,36
At 30% of useful heat output and at low temperature capacity P1 (HHV)	η1	G20	%	97,84	98,39	98,17	98,39	98,17
Auxiliary electrical consumption								
At full load	Elmax		W	951	1059	1446	1412	1928
At partial load	Elmin		W	228	297	330	396	440
In standby mode	PSB		W	18	18	24	24	32
Other parameters								
Thermal losses in Stand-by mode	Pstby		W	414,19	474,96	561,71	636,09	748,95
Pilot flame energy consumption	QHE		GJ	588	678	798,0	904	1064,0
Yearly energy consumption	LWA		dB(A)	60	61	62,00	63	64,00
Noise level, indoor (sound power)			mg/kWh	38,70	39,30	46,10	39,30	46,10
Nitrogen oxide emissions (NOx)				6	6	6	6	6
EMISSION VALUES AT MAX GAS FLOW *								
CO s.a. less than	G20	p.p.m.		91,5	89,0	91,5	89,0	91,5
	G31			163,0	177,0	185,0	177,0	185,0
CO ₂ **	G20	%		9,0	9,0	9,0	9,0	9,0
	G31			10,4	10,4	10,4	10,4	10,4
NOx s.a. less than	G20	p.p.m.		30	30	30	30	30
	G31			40	40	40	40	40
Flues temperature			°C	78,0	75,0	77,0	75,0	77,0
EMISSION VALUES AT MIN GAS FLOW								
CO s.a. less than	G20	p.p.m.		7,5	4,6	5,6	4,6	5,6
	G31			12,0	14,0	16,0	14,0	16,0
CO ₂ **	G20	%		9,0	9,0	9,0	9,0	9,0
	G31			10,4	10,4	10,4	10,4	10,4
NOx s.a. less than	G20	p.p.m.		30	30	30	30	30
	G31			40	40	40	40	40
Flues temperature			°C	62,0	61,0	61,0	61,0	61,0

* Values calculated according to UNI EN 15502 standard.

** Values referring to atmospheric pressure at sea level.

Overall dimensions and weights

POWER MAX BOX 130-2
 POWER MAX BOX 160-2
 POWER MAX BOX 200-2
 POWER MAX BOX 260-2

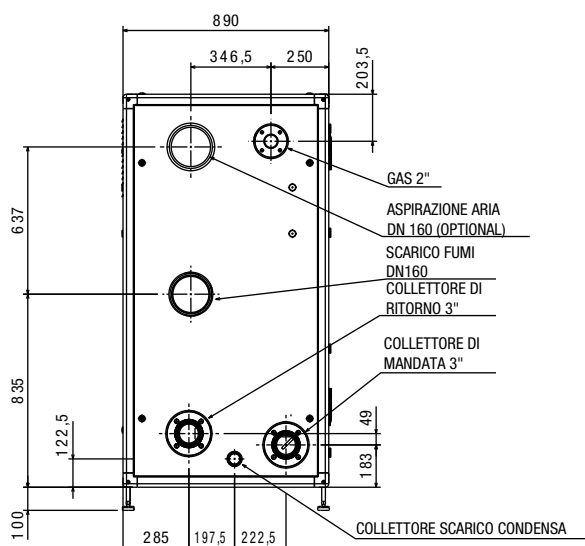
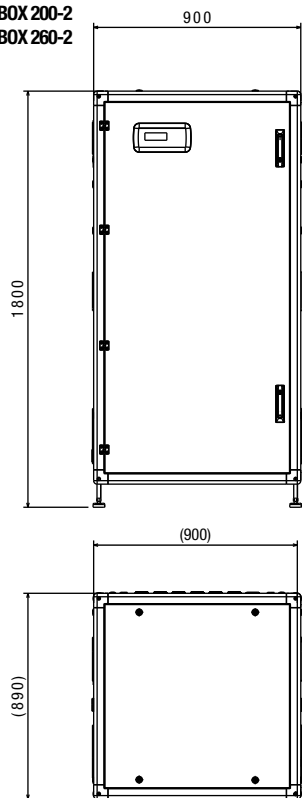

POWER MAX BOX 300-2

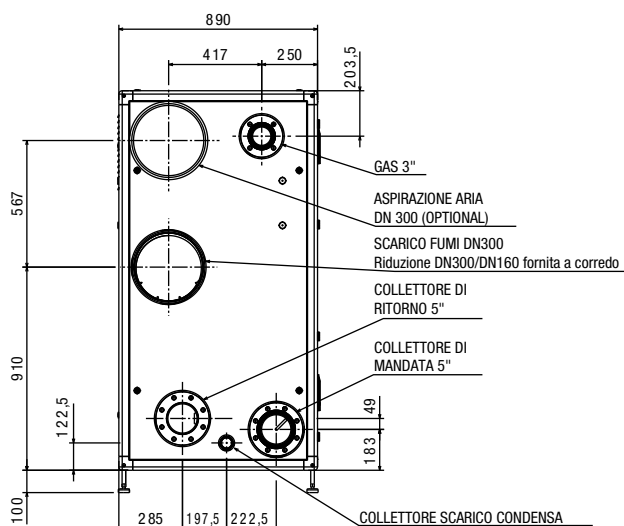
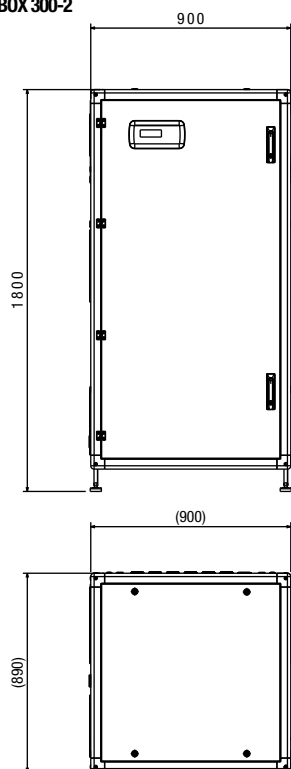

POWER MAX BOX 330-3
 POWER MAX BOX 390-3
 POWER MAX BOX 520-4

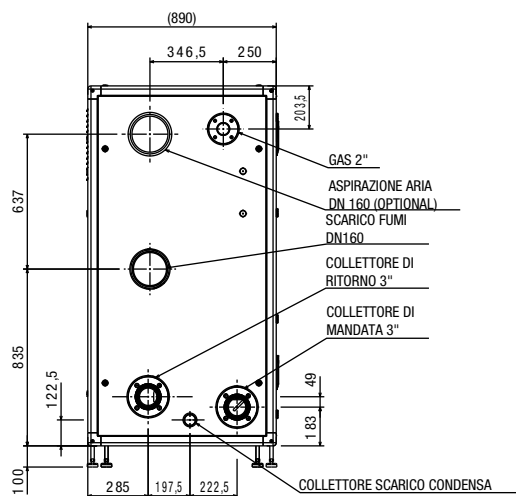
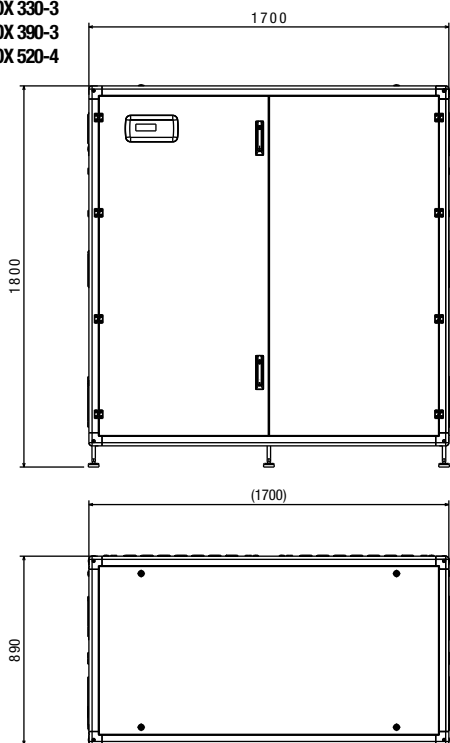

POWER MAX BOX 450-3
 POWER MAX BOX 600-4

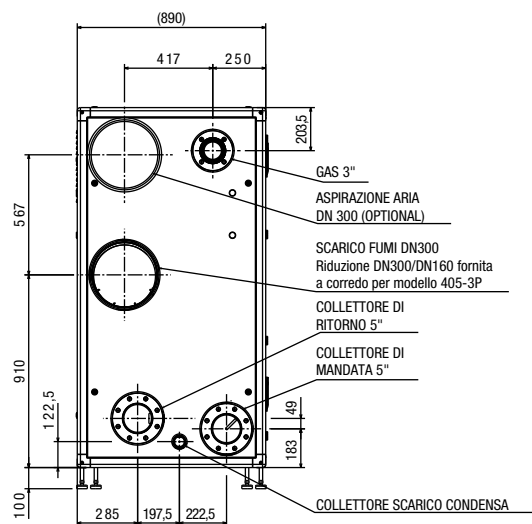
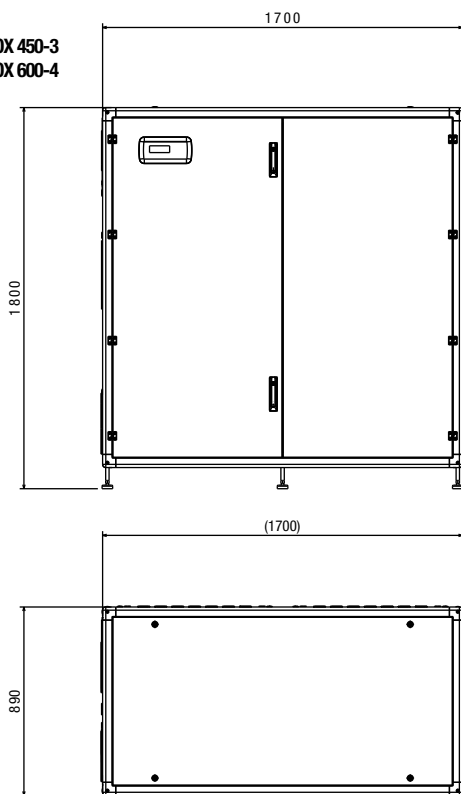

DESCRIPTION	U.M.	POWER MAX BOX				
		130-2	160-2	200-2	260-2	300-2
Heating flow diameter	Ø DN	3" DN80 PN6	3" DN80 PN6	3" DN80 PN6	3" DN80 PN6	5 "DN125 PN6
Heating Return diameter	Ø DN	3" DN80 PN6	3" DN80 PN6	3" DN80 PN6	3" DN80 PN6	5 "DN125 PN6
Gas inlet diameter	Ø DN	2" DN50 PN6	2" DN50 PN6	2" DN50 PN6	2" DN50 PN6	3" DN80 PN6
Condensate drain	Ø mm	50	50	50	50	50
Boiler height	mm	1800	1800	1800	1800	1800
Boiler width	mm	900	900	900	900	900
Boiler depth	mm	890	890	890	890	890
Flue discharge diameter	Ø mm	DN160	DN160	DN160	DN160	DN300/DN160
Air intake diameter (optional)	Ø mm	DN160	DN160	DN160	DN160	DN300
Empty weight	kg	270	270	280	300	350

DESCRIPTION	U.M.	POWER MAX BOX				
		330-3	390-3	450-3	520-4	600-4
Heating flow diameter	Ø DN	3" DN80 PN6	3" DN80 PN6	5 "DN125	3" DN80 PN6	5 "DN125
Heating Return diameter	Ø DN	3" DN80 PN6	3" DN80 PN6	5 "DN125	3" DN80 PN6	5 "DN125
Gas inlet diameter	Ø DN	2" DN50 PN6	2" DN50 PN6	3" DN80 PN6	2" DN50 PN6	3" DN80 PN6
Condensate drain	Ø mm	50	50	50	50	50
Boiler height	mm	1800	1800	1800	1800	1800
Boiler width	mm	1700	1700	1700	1700	1700
Boiler depth	mm	890	890	890	890	890
Flue discharge diameter	Ø mm	DN160	DN160	DN300/DN160	DN160	DN300
Air intake diameter (optional)	Ø mm	DN160	DN160	DN300	DN160	DN300
Empty weight	kg	450	490	540	560	600

System diagrams

Examples of installation with monobloc wall-hung MAX hybrid system

- Bivalent heating-only system with instantaneous DHW production modules

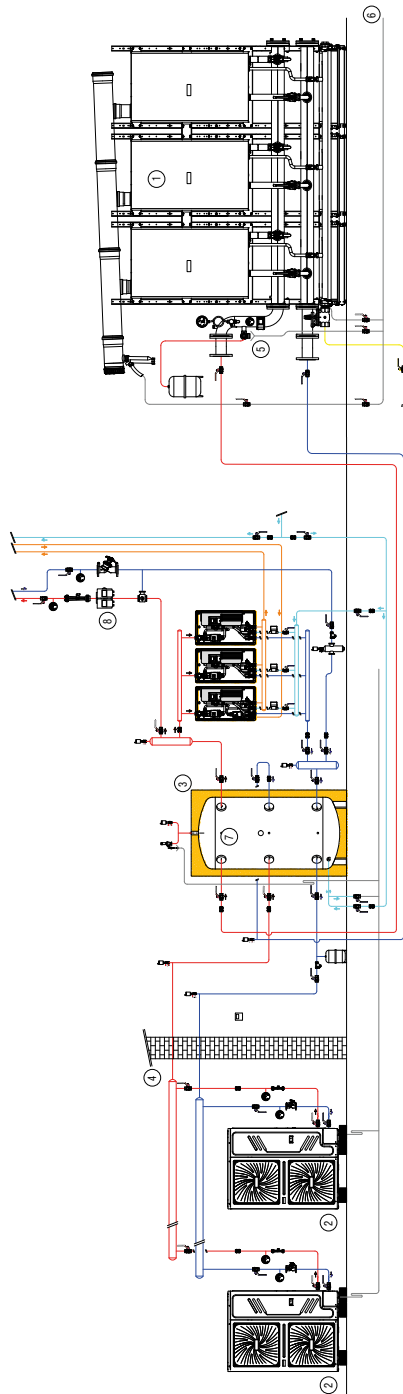

key

- | | |
|--|---|
| <ol style="list-style-type: none"> 1. POWER EVO-X / POWER MAX Condensing Boiler 2. HYDRO UNIT M 010-030 Heat pump 3. Inertial storage 4. External probe for boiler climatic thermoregulation | <ol style="list-style-type: none"> 5. safety accessory 6. Condensate drain 7. System probe + cascade probe + cylinder probe 8. System circulators (maximum management of 1 direct zone and 1 heating-only mix zone) |
|--|---|

- Bivalent hot and cold system with boiler for DHW production

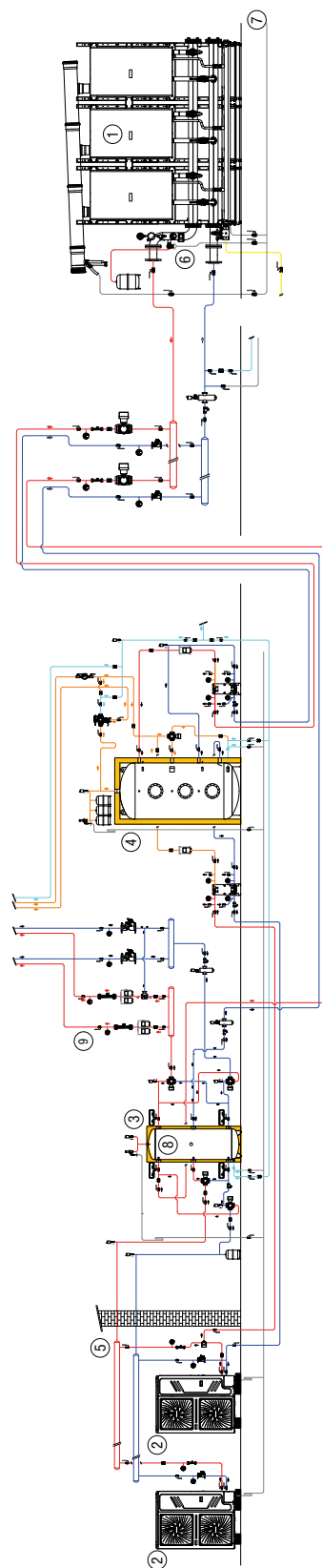

key

- | | |
|---|--|
| 1. POWER EVO-X / POWER MAX Condensing Boiler | 6. safety accessory |
| 2. HYDRO UNIT M 010-030 Heat pump | 7. Condensate drain |
| 3. Inertial storage | 8. System probe |
| 4. DHW Cylinder | 9. System circulators (management of 1 direct hot/cold zone and 1 heating-only mix zone) |
| 5. External probe for climatic thermoregulation (supplied with the heat pump) | |

Examples of installations with monobloc floor-standing BOX hybrid system

- Outdoor bivalent heating-only system with instantaneous DHW production modules

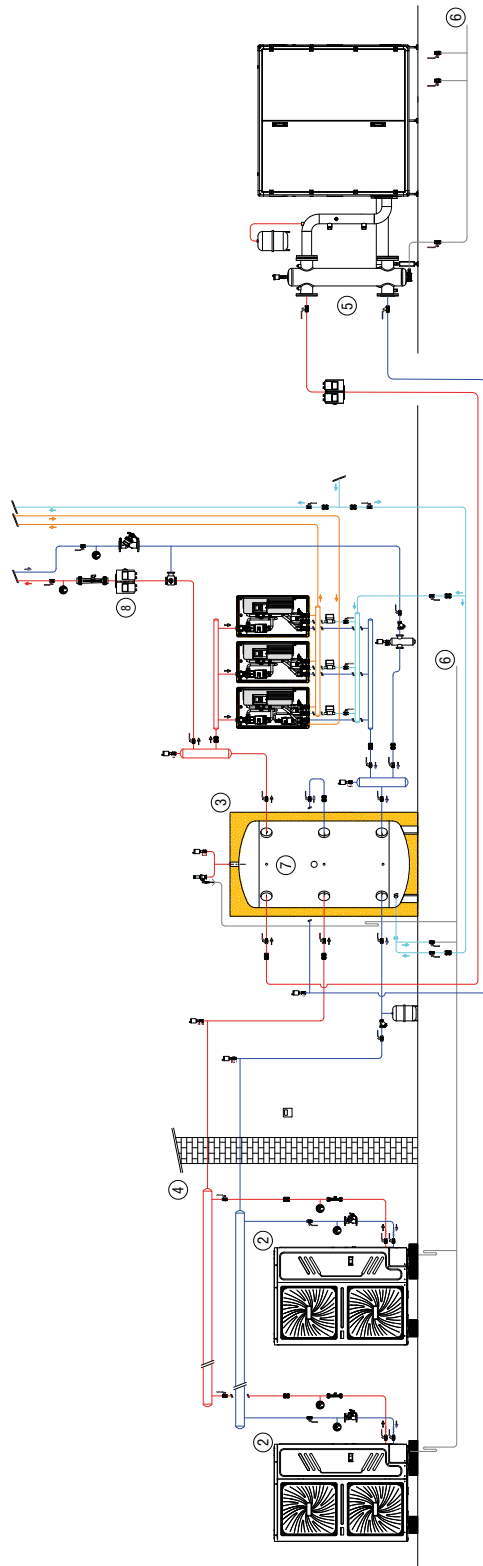

key

- | | |
|---|---|
| 1. POWER MAX BOX condensing boiler | 5. Hydraulic separator |
| 2. HYDRO UNIT M 010-030 Heat pump | 6. Condensate drain |
| 3. Inertial storage | 7. System probe |
| 4. External probe for climatic thermoregulation (supplied with the heat pump) | 8. System circulators (maximum management of 1 direct zone and 1 heating-only mix zone) |

- Bivalent outdoor hot and cold system with DHW production cylinder

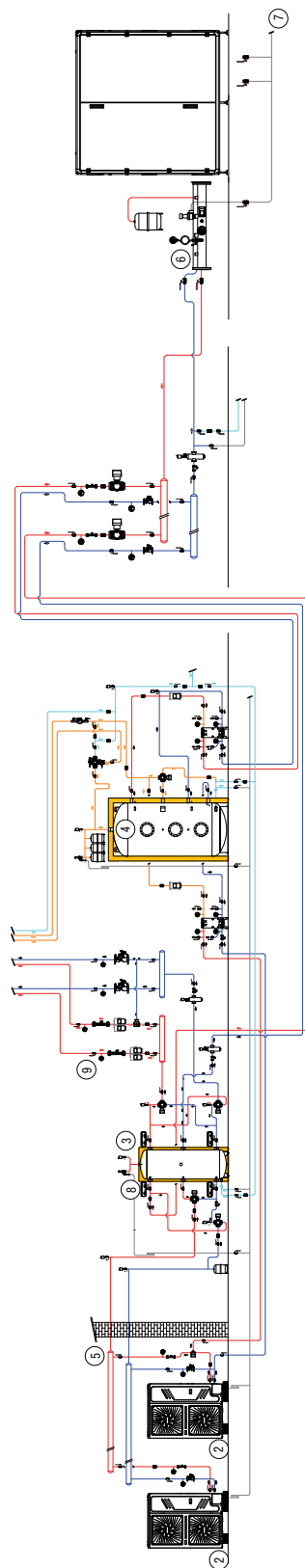

key

- | | |
|--|---|
| <ol style="list-style-type: none"> 1. POWER MAX BOX condensing boiler 2. HYDRO UNIT M 010-030 Heat pump 3. Inertial storage 4. DHW Cylinder 5. External probe for climatic thermoregulation (supplied with the heat pump) | <ol style="list-style-type: none"> 6. safety accessory 7. Condensate drain 8. System probe 9. System circulators (management of 1 direct hot/cold zone and 1 heating-only mix zone) |
|--|---|



RIELLO S.p.A.
Via Ing. Pilade Riello, 7
37045 Legnago (VR) - Italy
tel. +39 0442 630111

www.berettaheating.com

2702.1760 - EN - rev 01 02/2026



©2026 Carrier. All rights reserved.
All product and service marks mentioned in this document are the property of their respective owners.

Beretta reserves the right to change the information and specifications contained herein at any time and without notice. The contents and information provided herein are for informational purposes only and are not intended to provide legal or professional advice. This document, therefore, cannot be considered binding on third parties.